

MAXIM

MAX3658A Evaluation Kit

General Description

The MAX3658A evaluation kit is a fully assembled electrical demonstration kit that provides easy evaluation of the MAX3658A 622Mbps +3.3V trans-impedance amplifier.

Note that the MAX3658A evaluation kit provides an electrical interface to the IC that is similar, but not exactly the same as a photodiode.

Component List

DESIGNATION	QTY	DESCRIPTION
C0, C20	2	2.2 μ F \pm 10% Ceramic Capacitor (1206)
C1, C21	2	0.1 μ F \pm 10% Ceramic Capacitor (0603)
C2, C13	2	100pF \pm 5% Ceramic Capacitor (0201)
C3, C12, C15, C18, C23	5	2200pF \pm 5% Ceramic Capacitor (0201)
C4, C6 – C8, C14, C17, C19, C22, C24, C27	10	1 μ F \pm 5% Ceramic Capacitor (0603)
C5, C11	2	0.01 μ F \pm 10% Ceramic Capacitor (0402)
C9, C10, C29	3	0.022 μ F \pm 10% Ceramic Capacitor (0402)
J2, J3, J7, J15	4	SMB connectors (PCB-mount)
J4, J6, J20, J28, J30, JU1	6	2-pin headers (0.1in centers)
J9 – J11, J13, J14, J16, J19, J21 – J27	14	SMA connectors (edge-mount, tab contact)
L1, L2	2	600 Ω ferrite beads (0603) BLM15BD601SN
R0, R3	2	1.5k Ω \pm 1% resistor (0402)
R1, R2	2	3k Ω \pm 1% resistor (0402)
R4, R5	2	374 Ω \pm 1% resistor (0402)
R8 – R11, R26 – R29, R33, R34	10	150 Ω \pm 1% resistor (0402)
R12 – R14	3	51.1 Ω \pm 1% resistor (0402)
R16 – R21	6	2.37k Ω \pm 1% resistor (0402)

Features

- ◆ Easy +3.3V Electrical Evaluation of the MAX3658A
- ◆ Fully Assembled and Tested
- ◆ EV Kit Designed for 50 Ω Interfaces

Component List (cont.)

DESIGNATION	QTY	DESCRIPTION
R24, R25, R30, R31	4	1.58k Ω \pm 1% resistor (0402)
TP0 – TP11	12	TESTPOINT DIGI-KEY 5000K-ND
U0	1	User Supplied 5 PIN TO CAN
U1, U2	2	MAX3658AETA 8 TDFN
U3, U4	2	User Supplied 4 PIN TO CAN

Ordering Information

PART	TEMP. RANGE	IC PACKAGE
MAX3658AEVKIT	-40°C to +85°C	8- TDFN

Component Suppliers

SUPPLIER	PHONE	FAX
AVX	843-444-2863	843-626-3123
Coilcraft	847-639-6400	847-639-1469
Digi-Key	218-681-6674	218-681-3380
EF Johnson	402-474-4800	402-474-4858
Murata	415-964-6321	415-964-8165

Note: Please indicate that you are using the MAX3658A when ordering from these suppliers.

MAX3658A Evaluation Kit

Quick Start

Test Equipment Required

- +3.3V power supply with 100mA current capability
- Signal-source, 622Mbps capability
- Oscilloscope with at least 500MHz performance

Procedure

- 1) Connect a signal source to J11 (IN1 AC). Set the signal amplitude to 960mV_{P-P} (Corresponding to 200μA_{P-P} current into the TIA). Set the data rate to 622Mbps.
- 2) Apply 100μA to the IN1 DC input (J7) using a DC current source to emulate the DC component of the input signal. A voltage source connected from J7 to GND may be used if a DC current source is not available.
- 3) Connect OUT1+ (J10) and OUT1- (J9) to the 50Ω inputs of a high-speed oscilloscope.
- 4) Remove the shunt from J20 to enable the DC cancellation loop.
- 5) Install the shunt on J28 to enable the average current monitor.
- 6) Connect a +3.3V supply and ground to J2 SMB terminal.
- 7) The differential signal at the oscilloscope should be approximately 240mV_{P-P}.

Detailed Description

The MAX3658A accepts a DC-coupled input from a high-speed photodiode, for optical modulation amplitudes ranging from -33dBm to 0dBm. The MAX3658A evaluation board facilitates characterization of the MAX3658A TIA with or without a photodiode. The MAX3658A EV kit comes from the factory with a low input current and a high input current setup. The user must assemble the TO header sections, if used.

8 Pin TDFN Section

The 8pin TDFN section provides photodiode emulation using a simplified electrical photodiode model. The model provides a 50Ω electrical input termination, resistors that convert the high speed input voltage to high speed current. A DC path is provided to model the average photodiode current.

4 and 5 Pin TO Header Layout

The TO header assembly layout provides a user-assembled interface for evaluation of 4 and 5 pin TO headers. (See the MAX3658 datasheet for a suggested TO header layout.)

Test Equipment Interface

The MAX3658A outputs are back terminated with 75Ω. To facilitate interface with 50Ω equipment, the MAX3658A EV Kit places external 150Ω termination resistors in parallel with each output so that the EV Kit will match a 50Ω environment.

Note that the output load has a direct effect on the overall gain and output signal swing. Because of the external 150Ω resistors and the 50Ω environment, the overall gain is reduced by 33%. If matching a 50Ω environment is not critical, higher gain can be achieved by increasing the load resistance.

Photodiode Emulation

Use the following procedure to emulate the high-speed current signal generated by a photodiode:

Select the desired optical power (P_{AVE} in dBm) and extinction ratio (r_e).

Calculate the average current (I_{AVE} in Amps) as follows:

$$I_{AVG} = \frac{10^{(P_{AVE}/10)}}{1000} \rho$$

where ρ is photodiode responsivity in A/W

Calculate the AC signal current (I_{INPUT} in A_{P-P}) as follows, and adjust the signal generator to obtain it:

$$I_{INPUT} = 2I_{AVE} \frac{(r_e - 1)}{(r_e + 1)}$$

For example, to emulate a signal with an average power of -25dBm and an extinction ratio of 8 on the U1 electrical circuit.

-25dBm optical power will produce 2.7μA of average input current (assume a photodiode responsivity of 0.85A/W). Install a current meter between an external DC source and the IN1 DC test point. Adjust the source to provide 2.7μA.

The signal amplitude is $2I_{AVE}(r_e - 1)/(r_e + 1) = 4.2\mu A$. To generate this current through the 4.5kΩ series input resistors and the 300Ω internal resistance, set the signal source to produce an input of 20mV_{P-P} on the IN1 AC input.

For evaluation using the U2 electrical circuit note that the series input resistance is 748Ω along with a 300Ω internal resistance.

Noise measurements

Remove the input resistors and shunt capacitor before attempting noise measurements. With the input resistors and shunt capacitor removed, the total capacitance at the IN pin 0.5pF for the TDFN section.

MAX3658A Evaluation Kit

Evaluate: MAX3658A

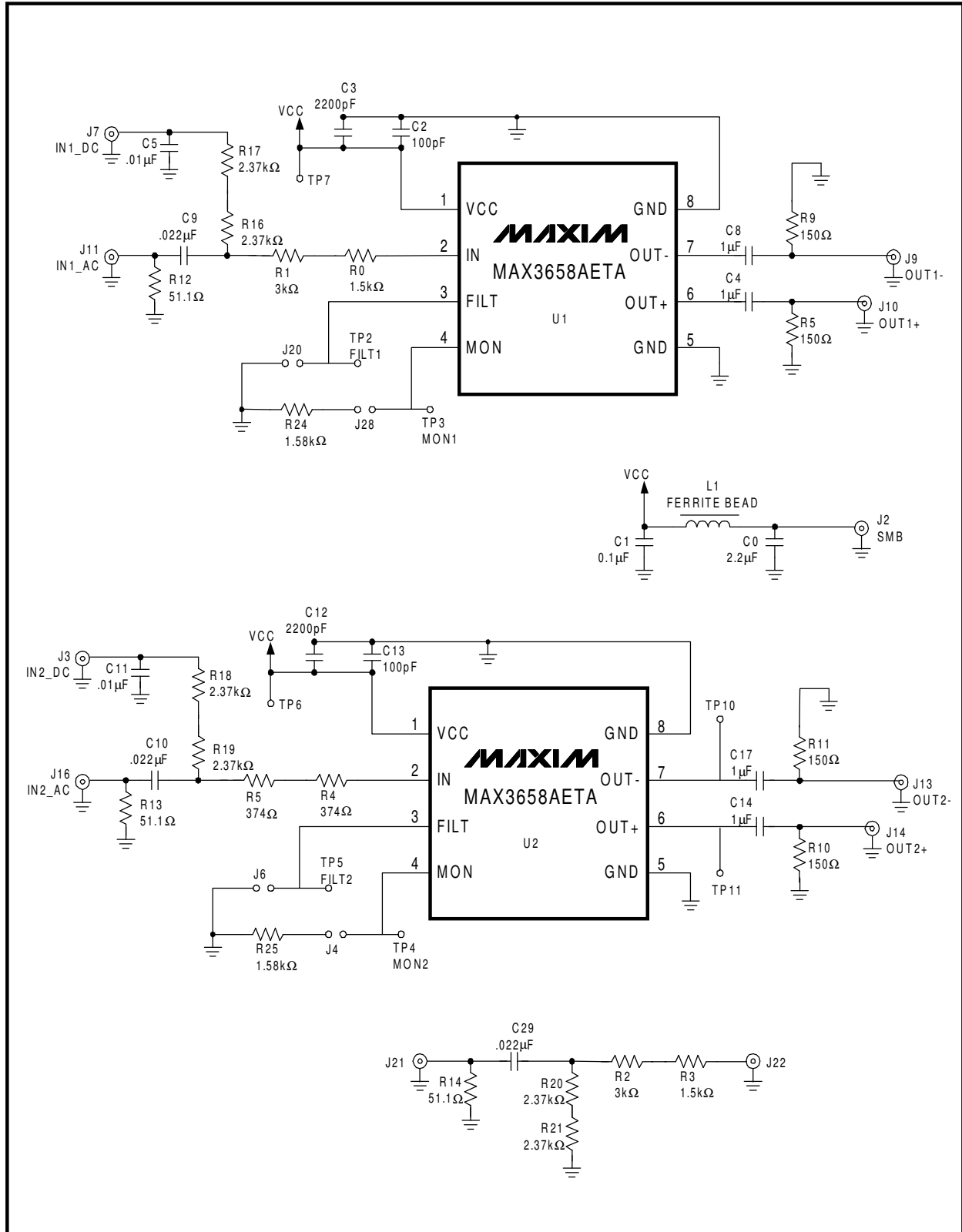

Figure 1. MAX3658A EV Kit Schematic Diagram

MAX3658A Evaluation Kit

Evaluate: MAX3658A

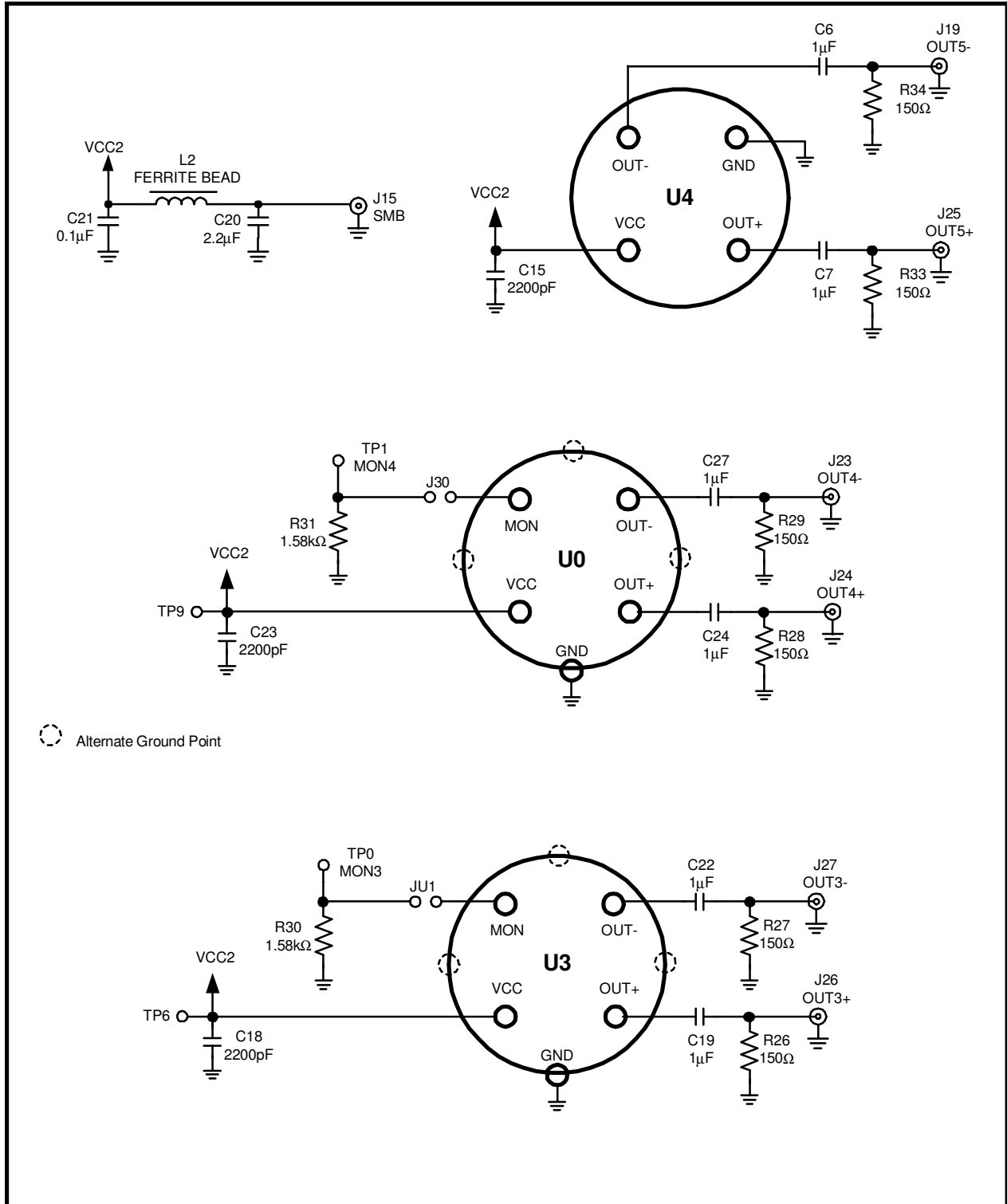

Figure 2. MAX3658A EV Kit Schematic Diagram - TO-Header Interface.

MAX3658A Evaluation Kit

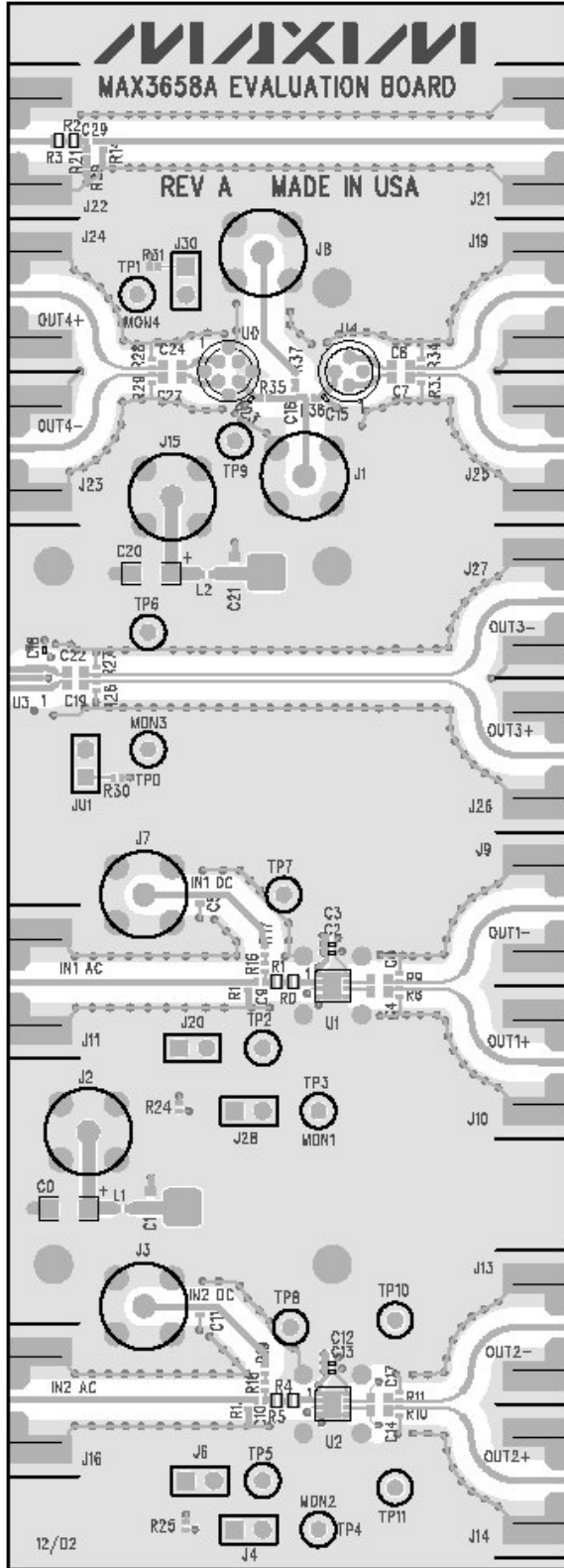

Figure 3. MAX3658A EV Kit Component Placement Guide - Component Side

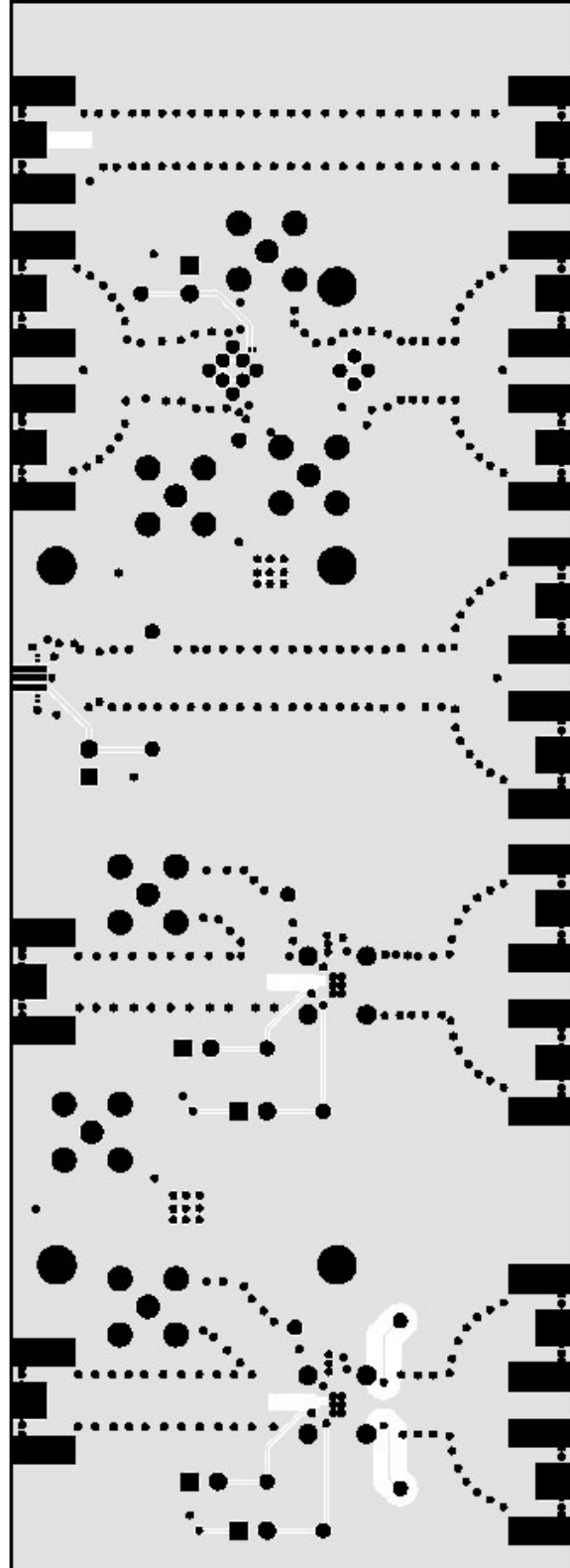

Figure 4. MAX3658A EV Kit PC Board Layout - Solder Side

Evaluate: MAX3658A

MAX3658A Evaluation Kit

Evaluate: MAX3658A

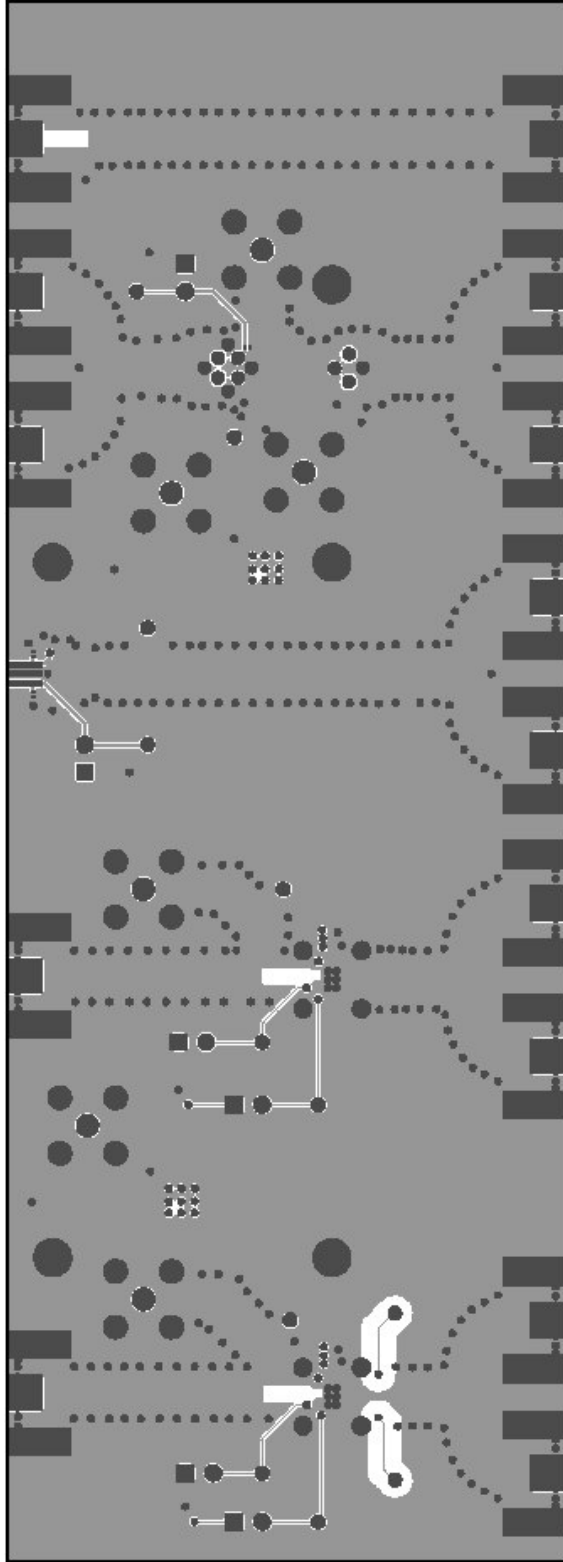

Figure 5. MAX3658A EV Kit PC Board Layout - Ground Plane

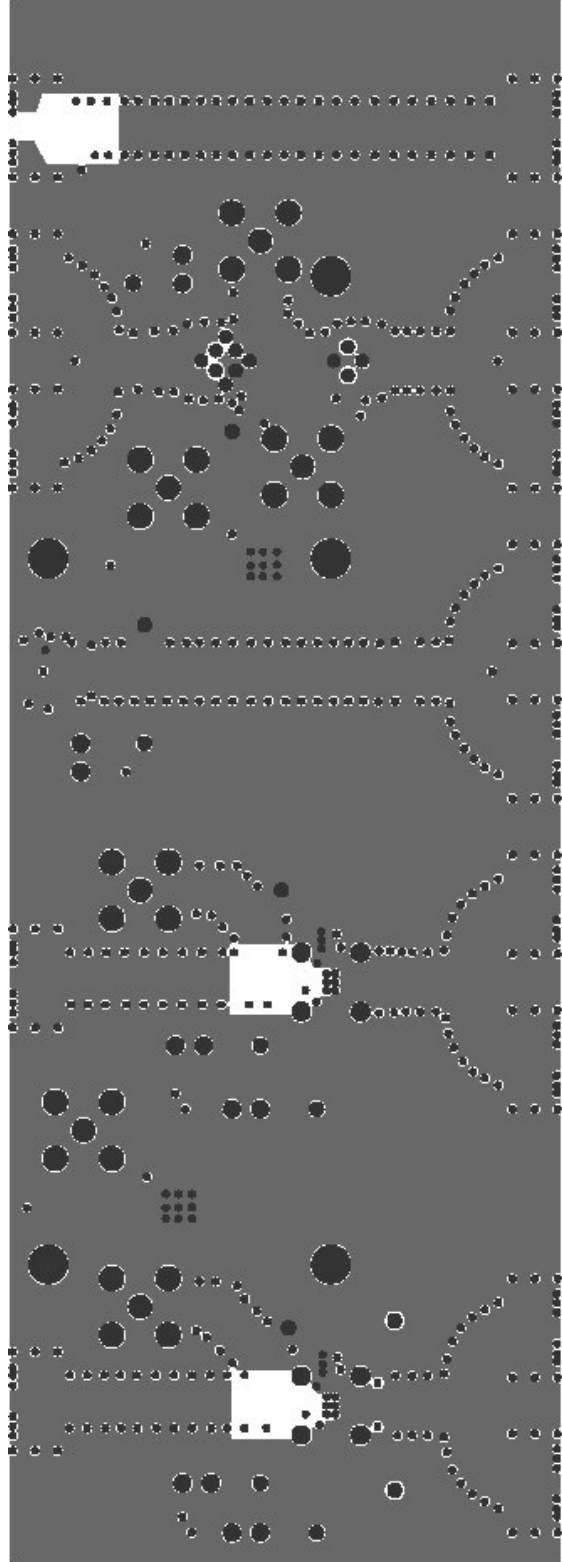

Figure 6. MAX3658A EV Kit PC Board Layout - Power Plane

Maxim cannot assume responsibility for use of any circuitry other than circuitry entirely embodied in a Maxim product. No circuit patent licenses are implied. Maxim reserves the right to change the circuitry and specifications without notice at any time.

6 _____ Maxim Integrated Products, 120 San Gabriel Drive, Sunnyvale, CA 94086 408-737-7600