



# Low-Voltage, Single-Supply, SPDT Analog Switch in SC70

MAX4599

## General Description

The MAX4599 single-pole/double-throw (SPDT) switch operates from a +2.0V to +5.5V single supply. It offers 60Ω max on-resistance (RON) at +5V and fast switching times (tON = 30ns max, tOFF = 25ns max).

The MAX4599 features excellent RON flatness (4Ω max) and matching (1Ω max) between channels. This device also offers 5pC max charge injection.

The MAX4599 is available in tiny 6-pin SC70 and SOT23 packages.

## Features

- ◆ Available in 6-Pin SC70 Package
- ◆ 60Ω max (40Ω typ) On-Resistance
- ◆ 1Ω max (0.2Ω typ) RON Matching Between Channels
- ◆ 4Ω max (2.5Ω typ) RON Flatness
- ◆ Fast Switching: tON = 30ns (max)  
tOFF = 25ns (max)
- ◆ Guaranteed 5pC max Charge Injection
- ◆ +2.0V to +5.5V Single-Supply Operation
- ◆ 200MHz -3dB Bandwidth
- ◆ Low ±0.5nA Leakage Current at +25°C
- ◆ Break-Before-Make Switching
- ◆ TTL/CMOS-Logic Compatible
- ◆ -76dB Off-Isolation at 1MHz
- ◆ 0.12% Total Harmonic Distortion

## Applications

- Battery-Operated Equipment
- Audio and Video Signal Routing
- Cellular Phones
- Low-Voltage Data-Acquisition Systems
- Sample-and-Hold Circuits
- Communications Circuits

## Ordering Information

PART	TEMP. RANGE	PIN-PACKAGE	TOP MARK
MAX4599EXT-T	-40°C to +85°C	6 SC70-6	AAF
MAX4599EUT-T	-40°C to +85°C	6 SOT23-6	AAHC

## Pin Configuration/Functional Diagram/Truth Table

**MAX4599**  
SC70-6/SOT23-6

MAX4599		
IN	NC	NO
0	ON	OFF
1	OFF	ON

SWITCH IS SHOWN FOR "0" INPUT.

# Low-Voltage, Single-Supply, SPDT Analog Switch in SC70

## ABSOLUTE MAXIMUM RATINGS

Voltage Referenced to GND

V+ .....	-0.3V to +6V
IN, COM, NO, NC (Note 1) .....	-0.3V to (V+ + 0.3V)
Continuous Current (any terminal) .....	±20mA
Peak Current, COM, NO, NC (pulsed at 1ms, 10% duty cycle) .....	±40mA

Continuous Power Dissipation (T<sub>A</sub> = +70°C)

6-Pin SC70-6 (derate 3.1mW/°C above +70°C) .....	245mW
6-Pin SOT23-6 (derate 7.1mW/°C above +70°C) .....	571mW
Operating Temperature Range	
MAX4599E_T .....	-40°C to +85°C
Storage Temperature Range .....	-65°C to +150°C
Lead Temperature (soldering, 10s) .....	+300°C

**Note 1:** Signals on NO, NC, COM, or IN exceeding V+ or GND are clamped by internal diodes. Limit forward-diode current to maximum current rating.

Stresses beyond those listed under "Absolute Maximum Ratings" may cause permanent damage to the device. These are stress ratings only, and functional operation of the device at these or any other conditions beyond those indicated in the operational sections of the specifications is not implied. Exposure to absolute maximum rating conditions for extended periods may affect device reliability.

## ELECTRICAL CHARACTERISTICS— Single +5V Supply

(V+ = +4.5V to +5.5V, V<sub>INH</sub> = +2.4V, V<sub>INL</sub> = +0.8V, T<sub>A</sub> = T<sub>MIN</sub> to T<sub>MAX</sub>, unless otherwise noted.) (Notes 2, 3)

PARAMETER	SYMBOL	CONDITIONS	MIN	TYP	MAX	UNITS	
<b>ANALOG SWITCH</b>							
Analog Signal Range	V <sub>COM</sub> , V <sub>NO</sub> , V <sub>NC</sub>		0		V+	V	
On-Resistance	R <sub>ON</sub>	V+ = 4.5V, I <sub>COM</sub> = 1mA, V <sub>NO</sub> or V <sub>NC</sub> = 3.5V	T <sub>A</sub> = +25°C	40	60	Ω	
			T <sub>A</sub> = T <sub>MIN</sub> to T <sub>MAX</sub>		65		
On-Resistance Match Between Channels (Note 4)	ΔR <sub>ON</sub>	V+ = 4.5V, I <sub>COM</sub> = 1A, V <sub>NO</sub> or V <sub>NC</sub> = 3.5V	T <sub>A</sub> = +25°C	0.2	1	Ω	
			T <sub>A</sub> = T <sub>MIN</sub> to T <sub>MAX</sub>		2		
On-Resistance Flatness (Note 5)	R <sub>FLAT(ON)</sub>	V+ = 4.5V; I <sub>COM</sub> = 1mA; V <sub>NO</sub> or V <sub>NC</sub> = 1V, 2.0V, 3.5V	T <sub>A</sub> = +25°C	2.5	4	Ω	
			T <sub>A</sub> = T <sub>MIN</sub> to T <sub>MAX</sub>		5		
NO, NC Off-Leakage Current (Note 6)	I <sub>NO(OFF)</sub> , I <sub>NC(OFF)</sub>	V+ = 5.5V; V <sub>COM</sub> = 1V, 4.5V; V <sub>NO</sub> or V <sub>NC</sub> = 4.5V, 1V	T <sub>A</sub> = +25°C	-0.5	0.01	0.5	nA
			T <sub>A</sub> = T <sub>MIN</sub> to T <sub>MAX</sub>	-5		5	
COM On-Leakage Current (Note 6)	I <sub>COM(ON)</sub>	V+ = 5.5V; V <sub>COM</sub> = 1V, 4.5V; V <sub>NO</sub> or V <sub>NC</sub> = 1V, 4.5V, or floating	T <sub>A</sub> = +25°C	-1	0.01	1	nA
			T <sub>A</sub> = T <sub>MIN</sub> to T <sub>MAX</sub>	-10		10	
<b>DIGITAL I/O</b>							
Input Logic High	V <sub>IH</sub>		2.4			V	
Input Logic Low	V <sub>IL</sub>				0.8	V	
<b>DYNAMIC</b>							
Turn-On Time	t <sub>ON</sub>	V <sub>NO</sub> , V <sub>NC</sub> = 3V; R <sub>L</sub> = 1kΩ; C <sub>L</sub> = 35pF; Figure 2	T <sub>A</sub> = +25°C	25	30	ns	
			T <sub>A</sub> = T <sub>MIN</sub> to T <sub>MAX</sub>		40		

# Low-Voltage, Single-Supply, SPDT Analog Switch in SC70

MAX4599

## ELECTRICAL CHARACTERISTICS—Single +5V Supply (continued)

(V+ = +4.5V to +5.5V, V<sub>INH</sub> = +2.4V, V<sub>INL</sub> = +0.8V, T<sub>A</sub> = T<sub>MIN</sub> to T<sub>MAX</sub>, unless otherwise noted.) (Notes 2, 3)

PARAMETER	SYMBOL	CONDITIONS	MIN	TYP	MAX	UNITS
Turn-Off Time	t <sub>OFF</sub>	V <sub>NO</sub> , V <sub>NC</sub> = 3V; R <sub>L</sub> = 1kΩ; C <sub>L</sub> = 35pF; Figure 2	T <sub>A</sub> = +25°C	20	25	ns
			T <sub>A</sub> = T <sub>MIN</sub> to T <sub>MAX</sub>		30	
Break-Before-Make	t <sub>BBM</sub>	V <sub>NO</sub> , V <sub>NC</sub> = 3V; R <sub>L</sub> = 1kΩ; C <sub>L</sub> = 35pF; Figure 3	T <sub>A</sub> = +25°C	10		ns
			T <sub>A</sub> = T <sub>MIN</sub> to T <sub>MAX</sub>	1		
On-Channel -3dB Bandwidth	BW	Signal = 0dBm, 50Ω in and out, Figure 5	T <sub>A</sub> = +25°C	200		MHz
Off-Isolation (Note 7)	V <sub>ISO</sub>	C <sub>L</sub> = 5pF; R <sub>L</sub> = 50Ω; f = 1MHz; V <sub>NO</sub> , V <sub>NC</sub> = 1V <sub>RMS</sub> ; Figure 5	T <sub>A</sub> = +25°C	-76		dB
Charge Injection (Note 6)	Q	V <sub>GEN</sub> = 0, R <sub>GEN</sub> = 0, C <sub>L</sub> = 1.0nF, Figure 4	T <sub>A</sub> = +25°C	3	5	pC
NO, NC Off-Capacitance	C <sub>NO(OFF)</sub> , C <sub>NC(OFF)</sub>	V <sub>NO</sub> , V <sub>NC</sub> = GND; f = 1MHz; Figure 6	T <sub>A</sub> = +25°C	8		pF
COM Off-Capacitance	C <sub>COM(OFF)</sub>	V <sub>COM</sub> = GND, f = 1MHz, Figure 6	T <sub>A</sub> = +25°C	8		pF
Switch On-Capacitance	C <sub>(ON)</sub>	V <sub>COM</sub> = V <sub>NO</sub> , V <sub>NC</sub> = GND, f = 1MHz, Figure 6	T <sub>A</sub> = +25°C	20		pF
Total Harmonic Distortion	THD	R <sub>L</sub> = 600Ω, V <sub>IN</sub> = 5Vp-p, f = 20Hz to 20kHz	T <sub>A</sub> = +25°C	0.12		%
<b>SUPPLY</b>						
Power-Supply Range	V+		2.0		5.5	V
Positive Supply Current	I+	V+ = 5.5V, V <sub>IN</sub> = 0 or V+	-1	0.001	1	μA

## ELECTRICAL CHARACTERISTICS—Single +3V Supply

(V+ = +2.7V to +3.6V, V<sub>INH</sub> = +2.0V, V<sub>INL</sub> = +0.8V, T<sub>A</sub> = T<sub>MIN</sub> to T<sub>MAX</sub>, unless otherwise noted.) (Notes 2, 3)

PARAMETER	SYMBOL	CONDITIONS	MIN	TYP	MAX	UNITS
<b>ANALOG SWITCH</b>						
Analog Signal Range	V <sub>COM</sub> , V <sub>NO</sub> , V <sub>NC</sub>		0		V+	V
On-Resistance	R <sub>ON</sub>	V+ = 2.7V, I <sub>COM</sub> = 1mA, V <sub>NO</sub> or V <sub>NC</sub> = 1V	T <sub>A</sub> = +25°C	60	95	Ω
			T <sub>A</sub> = T <sub>MIN</sub> to T <sub>MAX</sub>		105	
<b>DIGITAL I/O</b>						
Input Logic High	V <sub>IH</sub>		2.0			V
Input Logic Low	V <sub>IL</sub>				0.8	V

# Low-Voltage, Single-Supply, SPDT Analog Switch in SC70

## ELECTRICAL CHARACTERISTICS—Single +3V Supply (continued)

( $V_+ = +2.7V$  to  $+3.6V$ ,  $V_{INH} = +2.0V$ ,  $V_{INL} = +0.8V$ ,  $T_A = T_{MIN}$  to  $T_{MAX}$ , unless otherwise noted.) (Notes 2, 3)

PARAMETER	SYMBOL	CONDITIONS	MIN	TYP	MAX	UNITS
<b>DYNAMIC</b>						
Turn-On Time	$t_{ON}$	$V_{NO}, V_{NC} = 2V$ ; $R_L = 1k\Omega$ ; $C_L = 35pF$ ; Figure 2	$T_A = +25^\circ C$	40	45	ns
			$T_A = T_{MIN}$ to $T_{MAX}$		55	
Turn-Off Time	$t_{OFF}$	$V_{NO}, V_{NC} = 2V$ ; $R_L = 1k\Omega$ ; $C_L = 35pF$ ; Figure 2	$T_A = +25^\circ C$	30	35	ns
			$T_A = T_{MIN}$ to $T_{MAX}$		40	
Break-Before-Make	$t_{BBM}$	$V_{NO}, V_{NC} = 2V$ ; $R_L = 1k\Omega$ ; $C_L = 35pF$ ; Figure 3	$T_A = +25^\circ C$	13		ns
			$T_A = T_{MIN}$ to $T_{MAX}$	1		
Charge Injection (Note 6)	Q	$V_{GEN} = 0$ , $R_{GEN} = 0$ , $C_L = 1.0nF$ , Figure 4	$T_A = +25^\circ C$	2	5	pC
<b>SUPPLY</b>						
Positive Supply Current	$I_+$	$V_+ = 3.6V$ , $V_{IN} = 0$ or $V_+$	-1	0.001	1	$\mu A$

## ELECTRICAL CHARACTERISTICS—Single +2.5V Supply

( $V_+ = +2.5V$ ,  $V_{INH} = +2.0V$ ,  $V_{INL} = +0.6V$ ,  $T_A = T_{MIN}$  to  $T_{MAX}$ , unless otherwise noted.) (Notes 2, 3)

PARAMETER	SYMBOL	CONDITIONS	MIN	TYP	MAX	UNITS
<b>ANALOG SWITCH</b>						
Analog Signal Range	$V_{COM}$ , $V_{NO}, V_{NC}$		0		$V_+$	V
On-Resistance	$R_{ON}$	$V_+ = 2.5V$ , $I_{COM} = 1mA$ , $V_{NO}$ or $V_{NC} = 1V$	$T_A = +25^\circ C$	65	110	$\Omega$
			$T_A = T_{MIN}$ to $T_{MAX}$		120	
Input Logic High	$V_{IH}$		2.0			V
Input Logic Low	$V_{IL}$				0.6	V
<b>DYNAMIC</b>						
Turn-On Time	$t_{ON}$	$V_{NO}, V_{NC} = 2V$ ; $R_L = 1k\Omega$ ; $C_L = 35pF$ ; Figure 3	$T_A = +25^\circ C$	45	50	ns
			$T_A = T_{MIN}$ to $T_{MAX}$		60	
Turn-Off Time	$t_{OFF}$	$V_{NO}, V_{NC} = 2V$ ; $R_L = 1k\Omega$ ; $C_L = 35pF$ ; Figure 3	$T_A = +25^\circ C$	30	35	ns
			$T_A = T_{MIN}$ to $T_{MAX}$		45	

**Note 2:** Parameters are 100% tested at  $+25^\circ C$  only and guaranteed by correlation at the full rated temperature.

**Note 3:** The algebraic convention, where the most negative value is a minimum and the most positive value a maximum, is used in this data sheet.

**Note 4:**  $\Delta R_{ON} = R_{ON(MAX)} - R_{ON(MIN)}$ .

**Note 5:** Flatness is defined as the difference between the maximum and minimum value of on-resistance as measured over the specified analog signal ranges.

**Note 6:** Guaranteed by design.

**Note 7:** Off-Isolation =  $20\log_{10}(V_{COM} / V_{NO})$ ,  $V_{COM}$  = output,  $V_{NO}$  = input to off switch.

# Low-Voltage, Single-Supply, SPDT Analog Switch in SC70

## Typical Operating Characteristics

( $T_A = +25^\circ\text{C}$ , unless otherwise noted.)

MAX4599

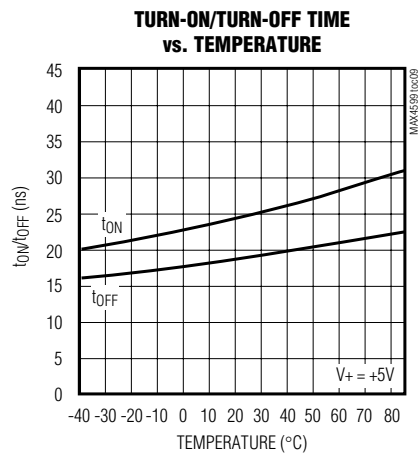
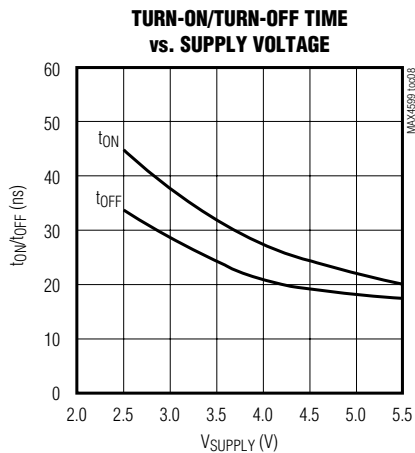
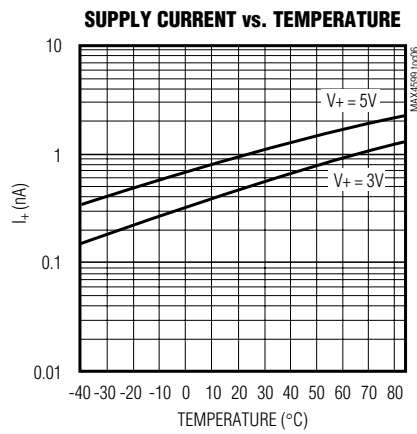
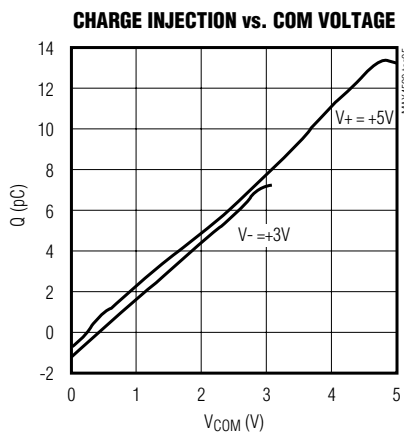
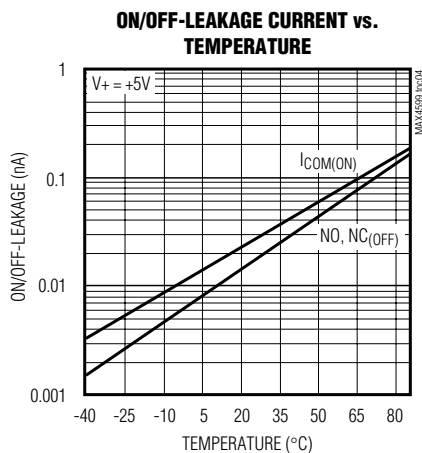
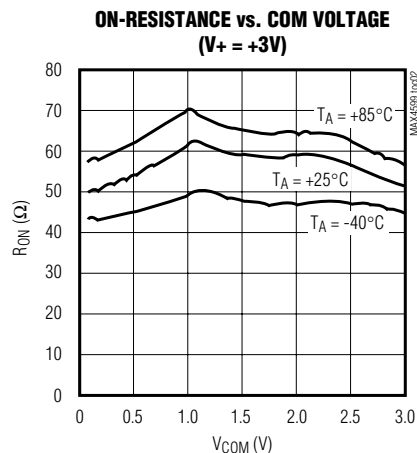
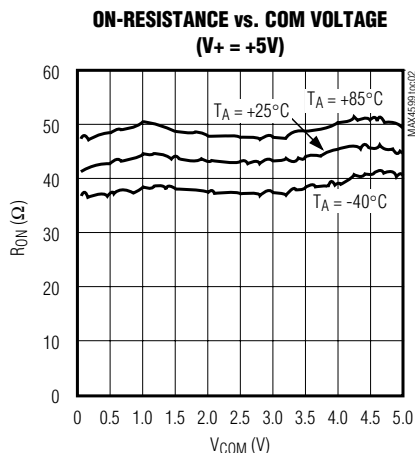
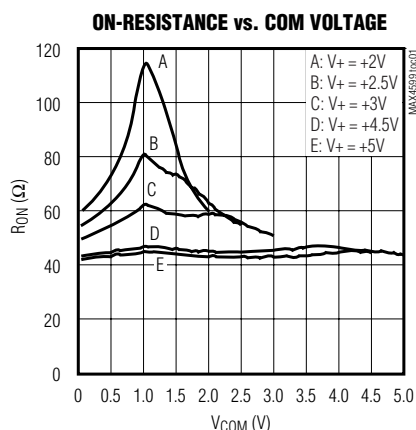

# Low-Voltage, Single-Supply, SPDT Analog Switch in SC70

## Typical Operating Characteristics (continued)

(T<sub>A</sub> = +25°C, unless otherwise noted.)

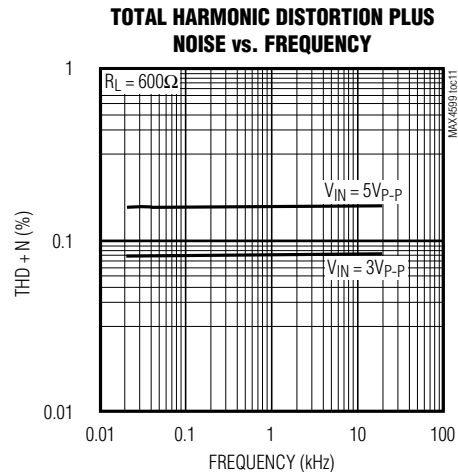
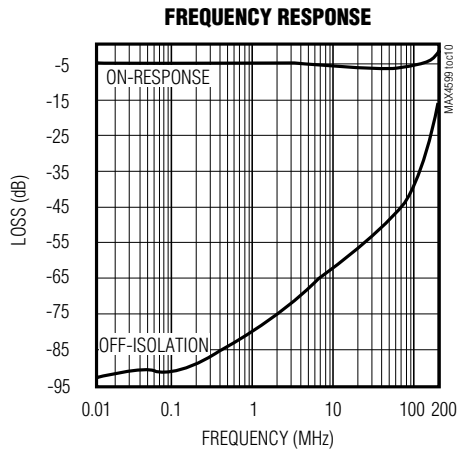

### Pin Description

PIN	NAME	FUNCTION
1	IN	Digital Control Input
2	V+	Positive Supply Voltage
3	GND	Ground
4	NC	Analog Switch Normally Closed
5	COM	Analog Switch Common
6	NO	Analog Switch Normally Open

### Applications Information

#### Analog Signal Levels

Analog signals can range over the supply voltage (V+ to GND) with on-resistance changing very little over the entire range (see *Typical Operating Characteristics*). The MAX4599 is bidirectional, so the NO, NC, and COM pins can be used either as inputs or outputs.

#### Power-Supply Sequencing and Overvoltage Protection

Proper power-supply sequencing is recommended for all CMOS devices. Always apply V+ before applying analog signals or logic inputs, especially if the analog or logic signals are not current limited. If this sequencing is not possible, and if the analog or logic inputs are not current limited to < 20mA, add a small-signal diode (D1) as shown in Figure 1. If the analog signal can dip below GND, add D2. Adding protection diodes

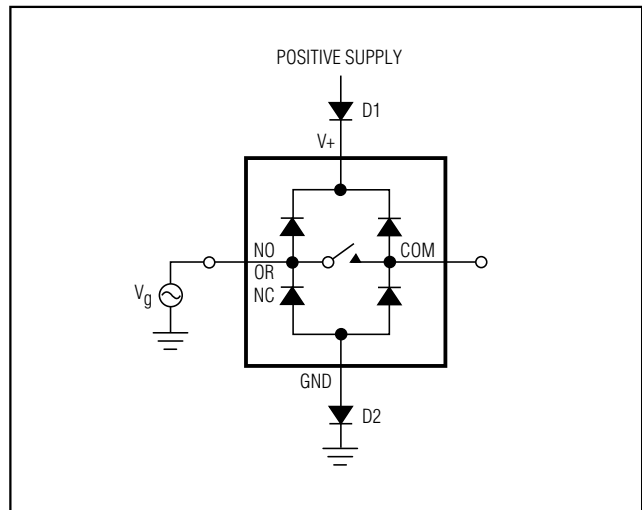

Figure 1. Overvoltage Protection Using Two External Blocking Diodes

reduces the analog signal range to a diode drop (about 0.7V) below V+ for D1 or to a diode drop above ground for D2. The addition of diodes does not affect leakage. On-resistance increases by a small amount at low supply voltages. Maximum supply voltage (V+) must not exceed 6V.

Protection diodes D1 and D2 also protect against some overvoltage situations. A fault voltage up to the absolute maximum rating at an analog signal input does not damage the device, even if the supply voltage is below the signal voltage.

# Low-Voltage, Single-Supply, SPDT Analog Switch in SC70

## Test Circuits/Timing Diagrams

MAX4599

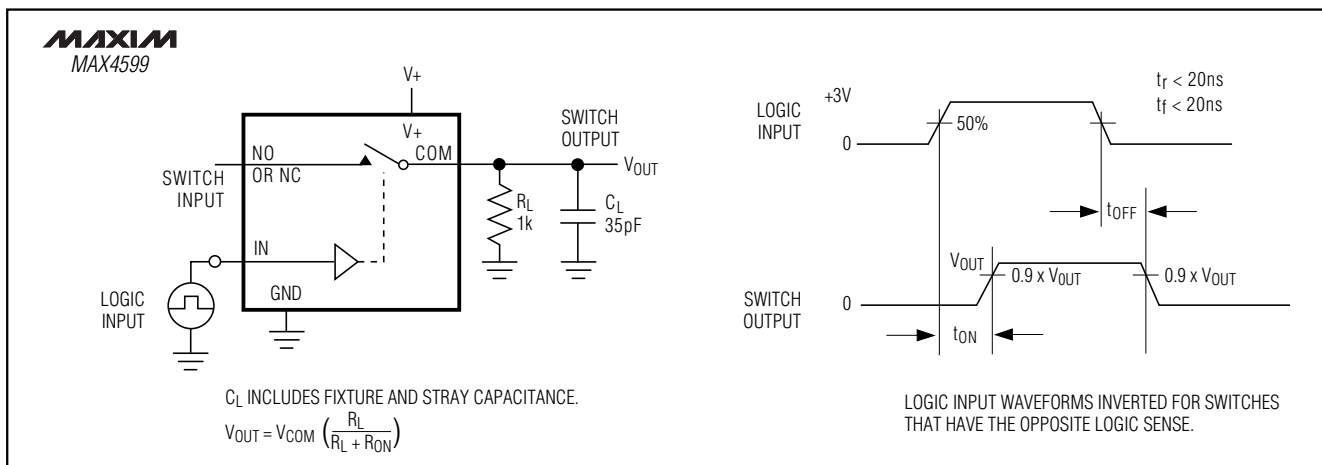

Figure 2. Switching Time

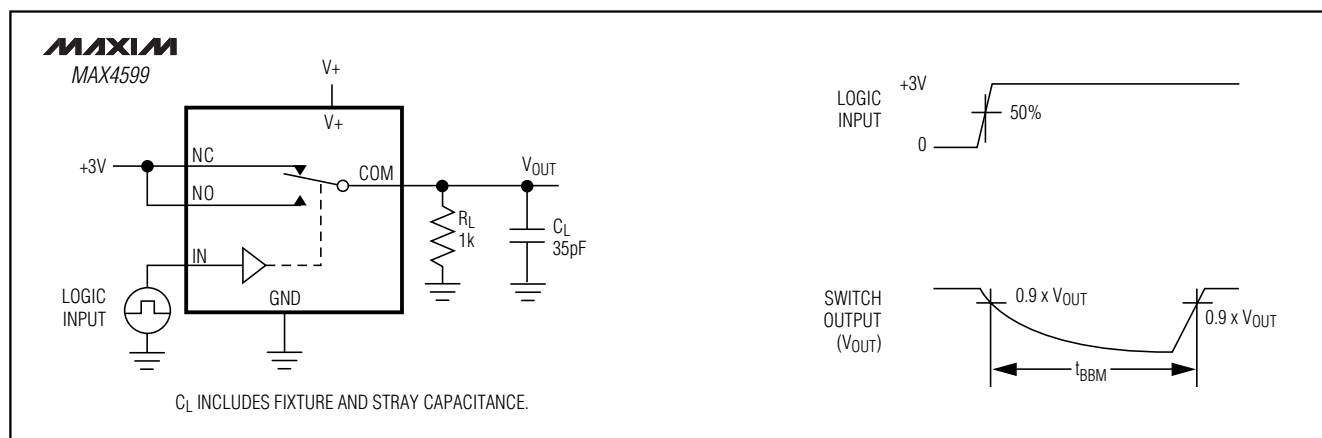

Figure 3. Break-Before-Make Interval

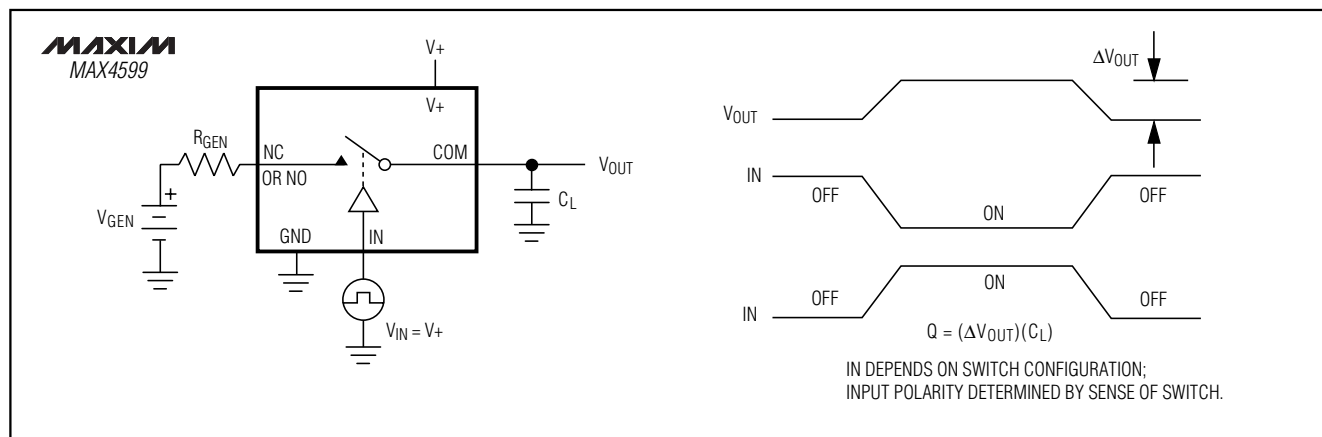

Figure 4. Charge Injection

# Low-Voltage, Single-Supply, SPDT Analog Switch in SC70

## Test Circuits/Timing Diagrams (continued)

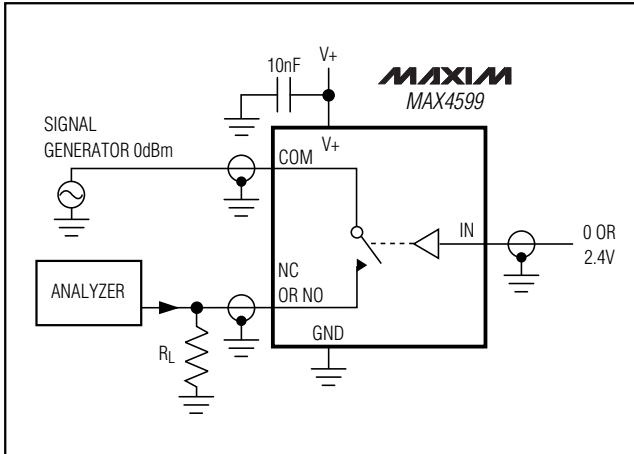

Figure 5. Off-Isolation/On-Channel Bandwidth

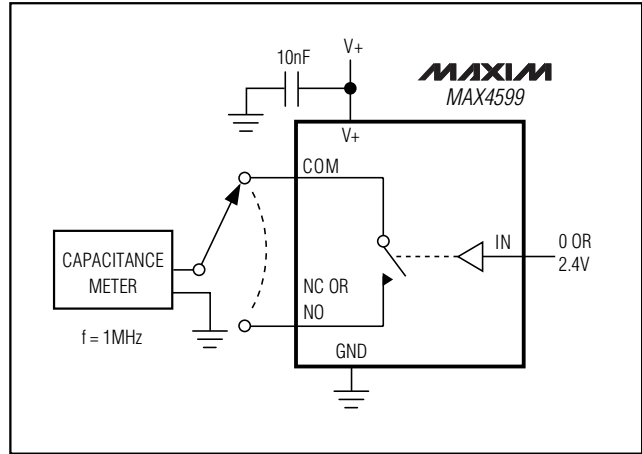

Figure 6. Channel On/Off-Capacitance

## Chip Information

TRANSISTOR COUNT: 89

## Package Information

SYMBOL	MIN	MAX
e	0.65	BSC
D	1.80	2.20
b	0.15	0.30
E	1.15	1.35
HE	1.80	2.40
Q1	0.10	0.40
A2	0.80	1.00
A1	0.00	0.10
A	0.80	1.10
c	0.10	0.18
L	0.10	0.30
L1	0.425	TYP.

1. ALL DIMENSIONS ARE IN MILLIMETERS
2. DIMENSIONS ARE INCLUSIVE OF PLATING
3. DIMENSIONS ARE EXCLUSIVE OF MOLD FLASH & METAL BURR
4. ALL SPECIFICATIONS COMPLY TO EIAJ SC70
5. COPLANARITY 4 MILS. MAX.
6. PIN 1 I.D. DOT

PROPRIETARY INFORMATION  
TITLE: PACKAGE OUTLINE, SC70, 6L  
APPROVAL: \_\_\_\_\_ DOCUMENT CONTROL NO: 21-0077 REV: B 1/1

Maxim cannot assume responsibility for use of any circuitry other than circuitry entirely embodied in a Maxim product. No circuit patent licenses are implied. Maxim reserves the right to change the circuitry and specifications without notice at any time.

8 Maxim Integrated Products, 120 San Gabriel Drive, Sunnyvale, CA 94086 408-737-7600