



Current Mode PWM Controller

FEATURES

- Optimized for Off-line and DC to DC Converters
- Low Start Up Current (<0.5mA)
- Trimmed Oscillator Discharge Current
- Automatic Feed Forward Compensation
- Pulse-by-Pulse Current Limiting
- Enhanced Load Response Characteristics
- Under-Voltage Lockout With Hysteresis
- Double Pulse Suppression
- High Current Totem Pole Output
- Internally Trimmed Bandgap Reference
- 500kHz Operation
- Low Ro Error Amp

DESCRIPTION

The UC1842A/3A/4A/5A family of control ICs is a pin for pin compatible improved version of the UC3842/3/4/5 family. Providing the necessary features to control current mode switched mode power supplies, this family has the following improved features. Start up current is guaranteed to be less than 0.5mA. Oscillator discharge is trimmed to 8.3mA. During under voltage lockout, the output stage can sink at least 10mA at less than 1.2V for Vcc over 5V.

The difference between members of this family are shown in the table below.

Part #	UVLO On	UVLO Off	Maximum Duty Cycle
UC1842A	16.0V	10.0V	<100%
UC1843A	8.5V	7.9V	<100%
UC1844A	16.0V	10.0V	<50%
UC1845A	8.5V	7.9V	<50%

BLOCK DIAGRAM

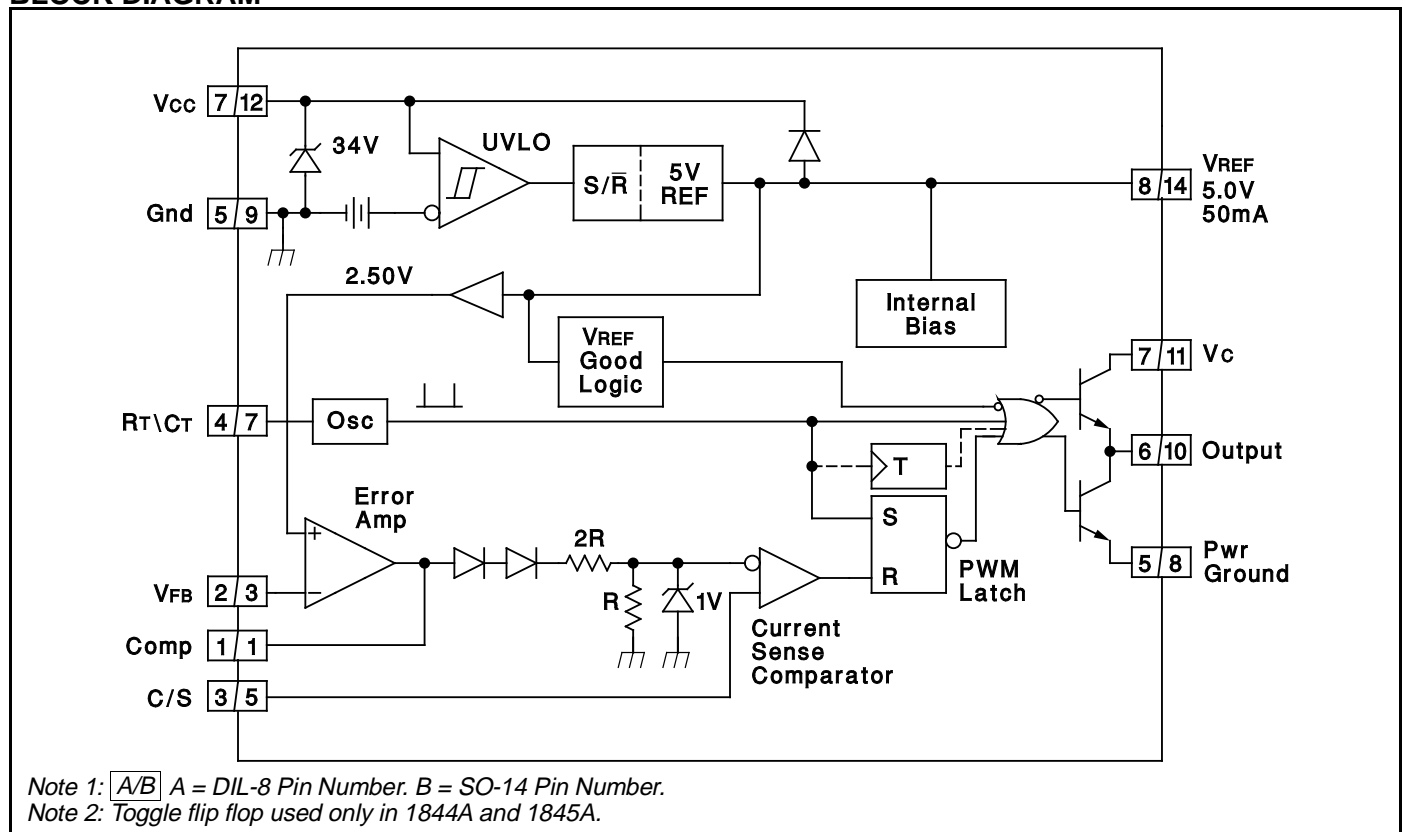

ABSOLUTE MAXIMUM RATINGS (Note 1)

Supply Voltage (Low Impedance Source)	30V
Supply Voltage (I _{CC} mA)	Self Limiting
Output Current	±1A
Output Energy (Capacitive Load)	5μJ
Analog Inputs (Pins 2, 3)	-0.3V to +6.3V
Error Amp Output Sink Current	10mA
Power Dissipation at T _A ≤ 25°C (DIL-8)	1W
Storage Temperature Range	-65°C to +150°C
Lead Temperature (Soldering, 10 Seconds)	300°C

Note 1. All voltages are with respect to Ground, Pin 5. Currents are positive into, negative out of the specified terminal. Consult Packaging Section of Databook for thermal limitations and considerations of packages. Pin numbers refer to DIL package only.

CONNECTION DIAGRAMS

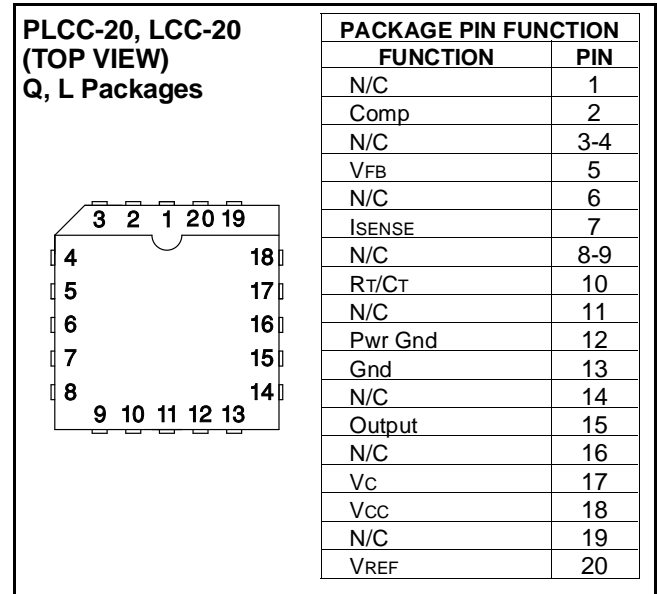
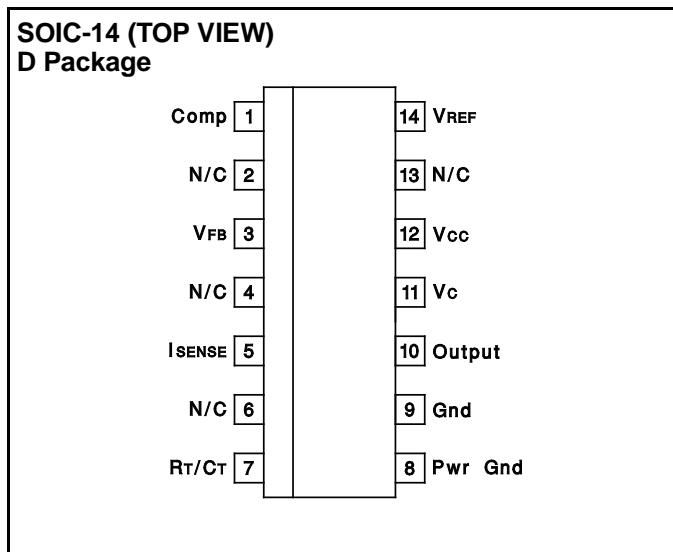
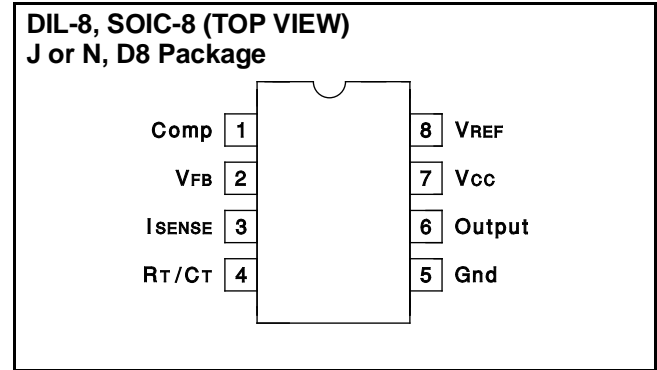

ELECTRICAL CHARACTERISTICS

Unless otherwise stated, these specifications apply for -55°C ≤ T_A ≤ 125°C for the UC184xA; -40°C ≤ T_A ≤ 85°C for the UC284xA; 0 ≤ T_A ≤ 70°C for the UC384xA; V_{CC} = 15V (Note 5); R_T = 10k; C_T = 3.3nF; T_A = T_J; Pin numbers refer to DIL-8.

PARAMETER	TEST CONDITIONS	UC184xA/UC284xA			UC384xA			UNITS
		MIN.	TYP.	MAX.	MIN.	TYP.	MAX.	
Reference Section								
Output Voltage	T _J = 25°C, I _o = 1mA	4.95	5.00	5.05	4.90	5.00	5.10	V
Line Regulation	12 ≤ V _{IN} ≤ 25V		6	20		6	20	mV
Load Regulation	1 ≤ I _o ≤ 20mA		6	25		6	25	mV
Temp. Stability	(Note 2, Note 7)		0.2	0.4		0.2	0.4	mV/°C
Total Output Variation	Line, Load, Temp.	4.9		5.1	4.82		5.18	V
Output Noise Voltage	10Hz ≤ f ≤ 10kHz T _J = 25°C (Note 2)		50			50		μV
Long Term Stability	T _A = 125°C, 1000Hrs. (Note 2)		5	25		5	25	mV
Output Short Circuit		-30	-100	-180	-30	-100	-180	mA
Oscillator Section								
Initial Accuracy	T _J = 25°C (Note 6)	47	52	57	47	52	57	kHz
Voltage Stability	12 ≤ V _{CC} ≤ 25V		0.2	1		0.2	1	%
Temp. Stability	T _{MIN} ≤ T _A ≤ T _{MAX} (Note 2)		5			5		%
Amplitude	V _{PIN 4} peak to peak (Note 2)		1.7			1.7		V
Discharge Current	T _J = 25°C, V _{PIN 4} = 2V (Note 8)	7.8	8.3	8.8	7.8	8.3	8.8	mA
	V _{PIN 4} = 2V (Note 8)	7.5		8.8	7.6		8.8	mA

ELECTRICAL CHARACTERISTICS (cont.) Unless otherwise stated, these specifications apply for $-55^{\circ}\text{C} \leq T_A \leq 125^{\circ}\text{C}$ for the UC184xA; $-40^{\circ}\text{C} \leq T_A \leq 85^{\circ}\text{C}$ for the UC284xA; $0 \leq T_A \leq 70^{\circ}\text{C}$ for the UC384xA; $V_{CC} = 15\text{V}$ (Note 5); $R_T = 10\text{k}$; $C_T = 3.3\text{nF}$; $T_A = T_J$; Pin numbers refer to DIL-8.

PARAMETER	TEST CONDITIONS	UC184xA/UC284xA			UC384xA			UNITS
		MIN.	TYP.	MAX.	MIN.	TYP.	MAX.	
Error Amp Section								
Input Voltage	$V_{PIN1} = 2.5\text{V}$	2.45	2.50	2.55	2.42	2.50	2.58	V
Input Bias Current			-0.3	-1		-0.3	-2	μA
AVOL	$2 \leq V_O \leq 4\text{V}$	65	90		65	90		dB
Unity Gain Bandwidth	$T_J = 25^{\circ}\text{C}$ (Note 2)	0.7	1		0.7	1		MHz
PSRR	$12 \leq V_{CC} \leq 25\text{V}$	60	70		60	70		dB
Output Sink Current	$V_{PIN2} = 2.7\text{V}$, $V_{PIN1} = 1.1\text{V}$	2	6		2	6		mA
Output Source Current	$V_{PIN2} = 2.3\text{V}$, $V_{PIN1} = 5\text{V}$	-0.5	-0.8		-0.5	-0.8		mA
VOUT High	$V_{PIN2} = 2.3\text{V}$, $R_L = 15\text{k}$ to ground	5	6		5	6		V
VOUT Low	$V_{PIN2} = 2.7\text{V}$, $R_L = 15\text{k}$ to Pin 8		0.7	1.1		0.7	1.1	V
Current Sense Section								
Gain	(Note 3, Note 4)	2.85	3	3.15	2.85	3	3.15	V/V
Maximum Input Signal	$V_{PIN1} = 5\text{V}$ (Note 3)	0.9	1	1.1	0.9	1	1.1	V
PSRR	$12 \leq V_{CC} \leq 25\text{V}$ (Note 3)		70			70		dB
Input Bias Current			-2	-10		-2	-10	μA
Delay to Output	$V_{PIN3} = 0$ to 2V (Note 2)		150	300		150	300	ns
Output Section								
Output Low Level	$I_{SINK} = 20\text{mA}$		0.1	0.4		0.1	0.4	V
	$I_{SINK} = 200\text{mA}$		15	2.2		15	2.2	V
Output High Level	$I_{SOURCE} = 20\text{mA}$	13	13.5		13	13.5		V
	$I_{SOURCE} = 200\text{mA}$	12	13.5		12	13.5		V
Rise Time	$T_J = 25^{\circ}\text{C}$, $C_L = 1\text{nF}$ (Note 2)		50	150		50	150	ns
Fall Time	$T_J = 25^{\circ}\text{C}$, $C_L = 1\text{nF}$ (Note 2)		50	150		50	150	ns
UVLO Saturation	$V_{CC} = 5\text{V}$, $I_{SINK} = 10\text{mA}$		0.7	1.2		0.7	1.2	V
Under-Voltage Lockout Section								
Start Threshold	x842A/4A	15	16	17	14.5	16	17.5	V
	x843A/5A	7.8	8.4	9.0	7.8	8.4	9.0	V
Min. Operation Voltage After TurnOn	x842A/4A	9	10	11	8.5	10	11.5	V
	x843A/5A	7.0	7.6	8.2	7.0	7.6	8.2	V
PWM Section								
Maximum Duty Cycle	x842A/3A	94	96	100	94	96	100	%
	x844A/5A	47	48	50	47	48	50	%
Minimum Duty Cycle				0			0	%
Total Standby Current								
Start-Up Current			0.3	0.5		0.3	0.5	mA
Operating Supply Current	$V_{PIN2} = V_{PIN3} = 0\text{V}$		11	17		11	17	mA
Vcc Zener Voltage	$I_{CC} = 25\text{mA}$	30	34		30	34		V

Note 2: These parameters, although guaranteed, are not 100% tested in production.

Note 3: Parameter measured at trip point of latch with $V_{PIN2} = 0$.

Note 4: Gain defined as: $A = \frac{\Delta V_{PIN1}}{\Delta V_{PIN3}}$; $0 \leq V_{PIN3} \leq 0.8\text{V}$.

Note 5: Adjust V_{CC} above the start threshold before setting at 15V.

Note 6: Output frequency equals oscillator frequency for the UC1842A and UC1843A. Output frequency is one half oscillator frequency for the UC1844A and UC1845A.

Note 7: "Temperature stability, sometimes referred to as average temperature coefficient, is described by the equation:

$$\text{Temp Stability} = \frac{V_{REF(max)} - V_{REF(min)}}{T_J(max) - T_J(min)}$$

$V_{REF(max)}$ and $V_{REF(min)}$ are the maximum & minimum reference voltage measured over the appropriate temperature range. Note that the extremes in voltage do not necessarily occur at the extremes in temperature."

Note 8: This parameter is measured with $R_T = 10\text{k}\Omega$ to V_{REF} . This contributes approximately $300\mu\text{A}$ of current to the measurement. The total current flowing into the R_T/C_T pin will be approximately $300\mu\text{A}$ higher than the measured value.

Error Amp Configuration

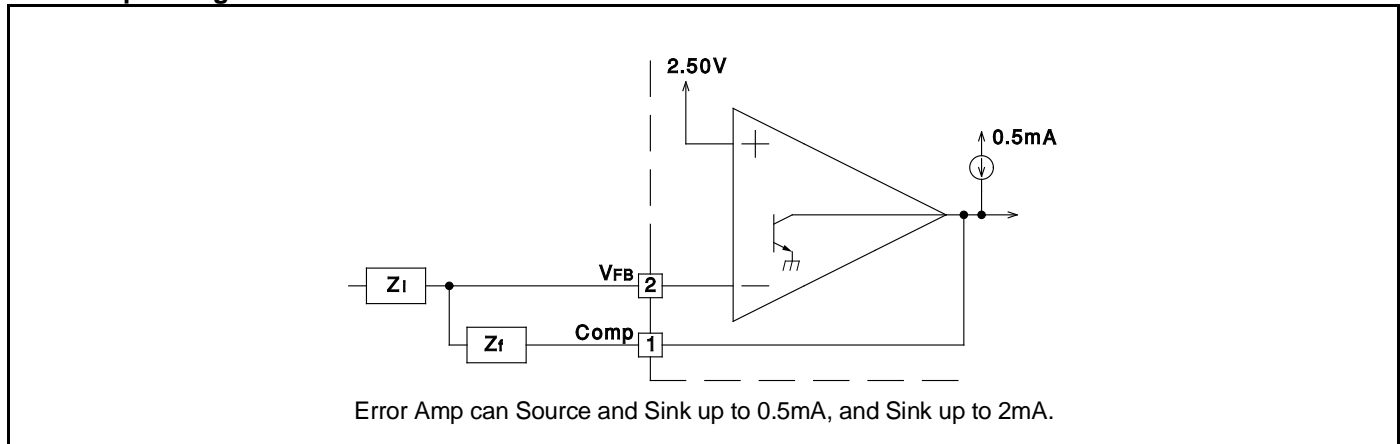

Under-Voltage Lockout

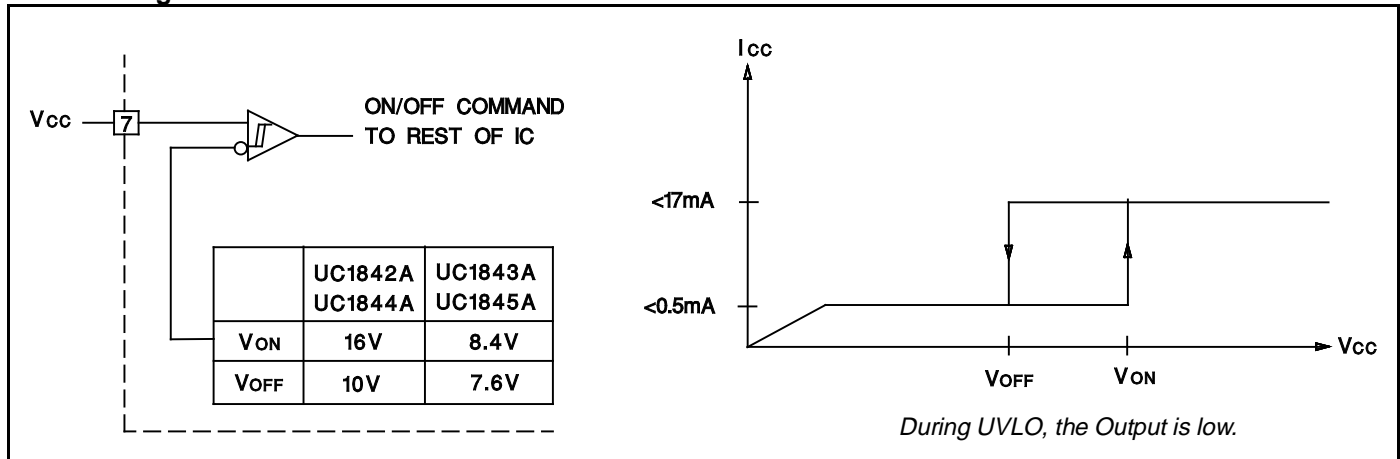

Current Sense Circuit

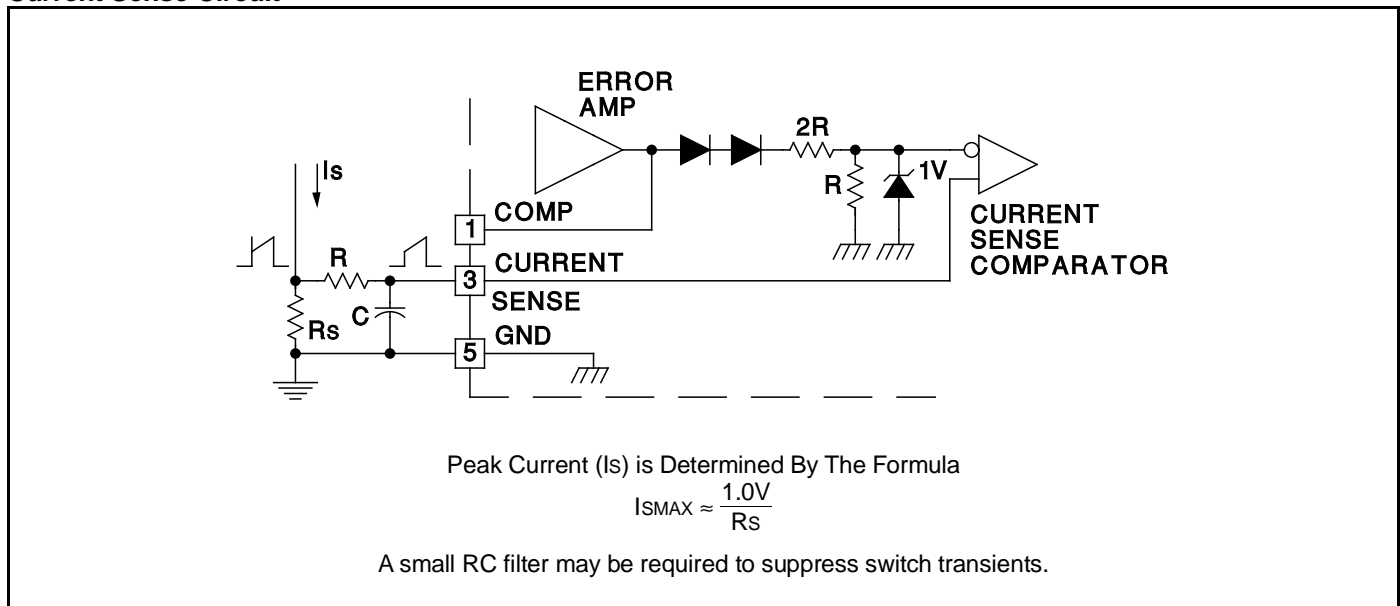

APPLICATIONS DATA (cont.)

Output Saturation Characteristics

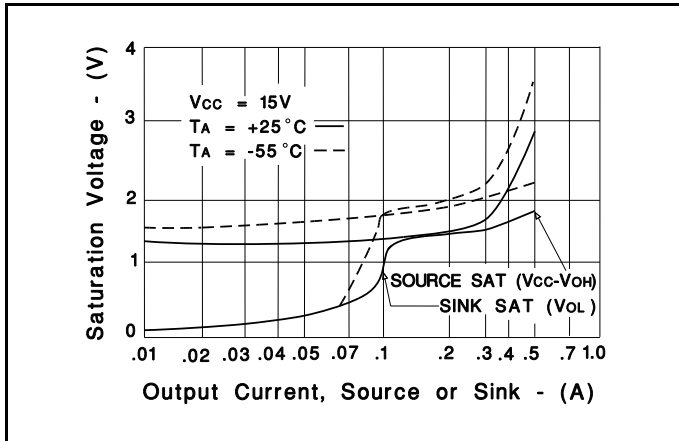

Error Amplifier Open-Loop Frequency Response

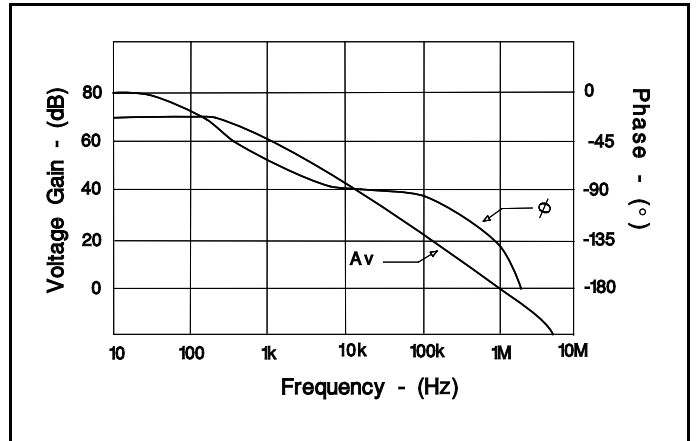

Oscillator Section

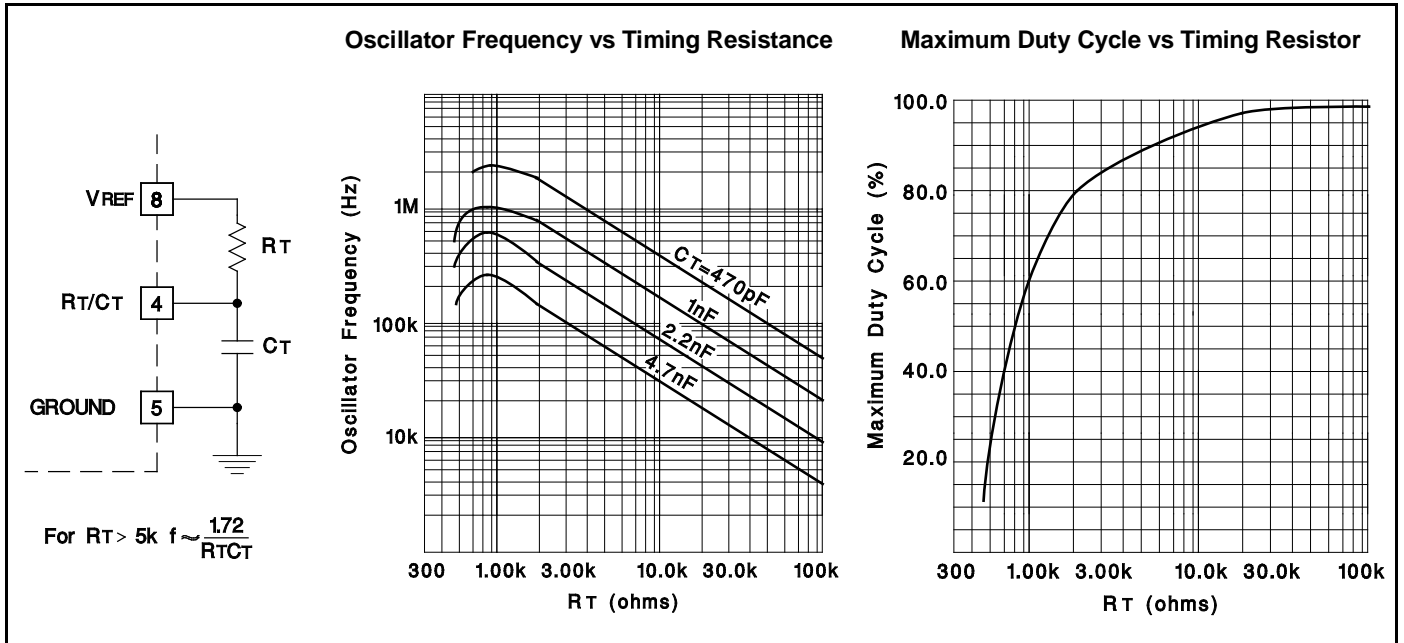

Open-Loop Laboratory Test Fixture

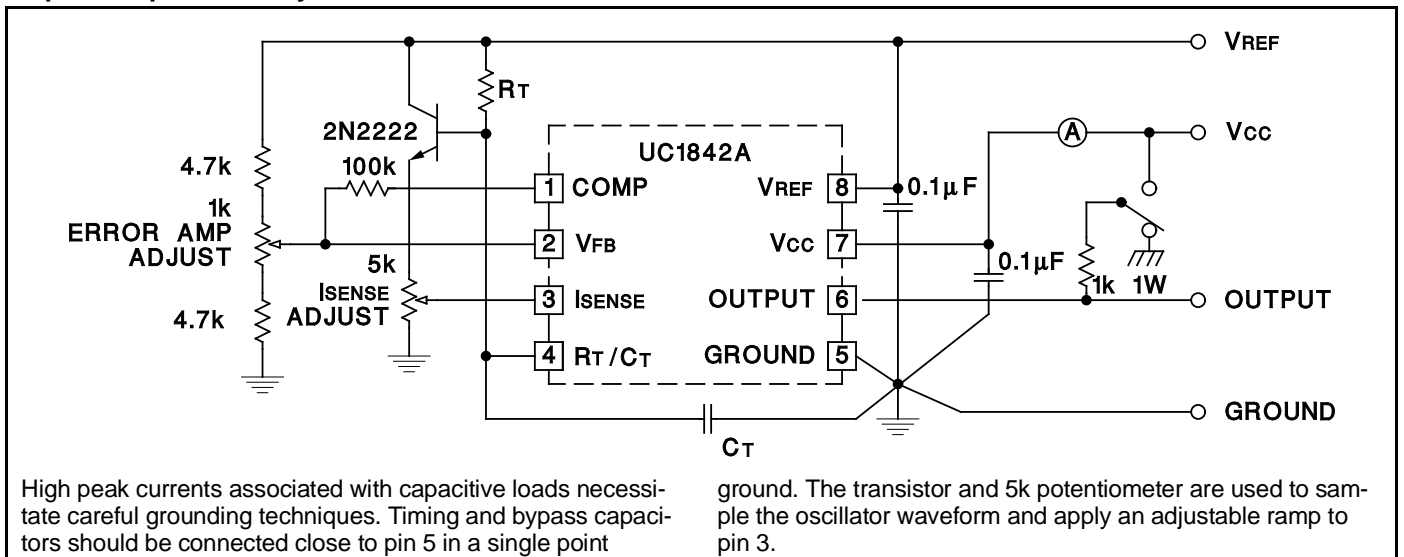

High peak currents associated with capacitive loads necessitate careful grounding techniques. Timing and bypass capacitors should be connected close to pin 5 in a single point

ground. The transistor and 5k potentiometer are used to sample the oscillator waveform and apply an adjustable ramp to pin 3.

APPLICATIONS DATA (cont.)

Off-line Flyback Regulator

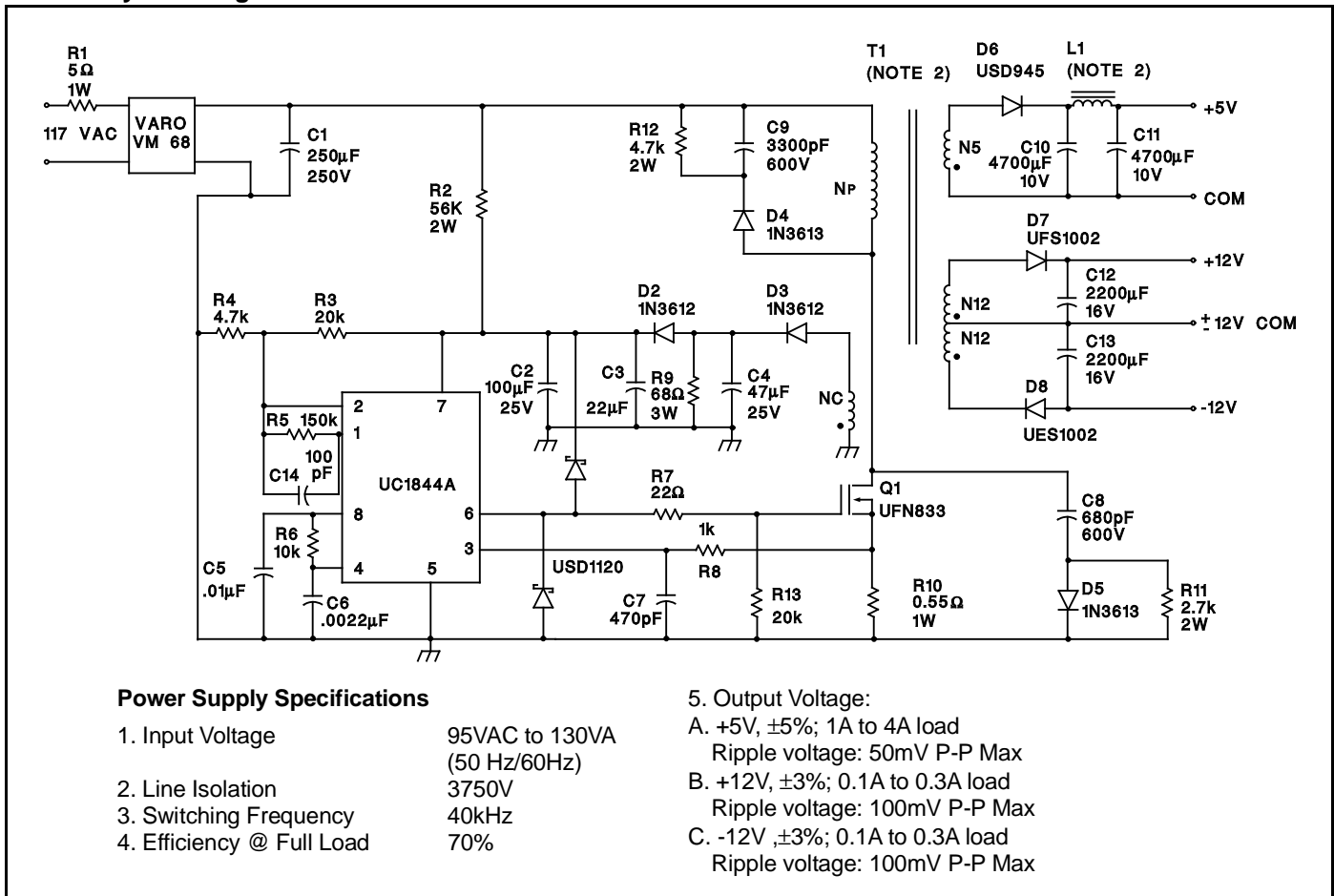

Slope Compensation

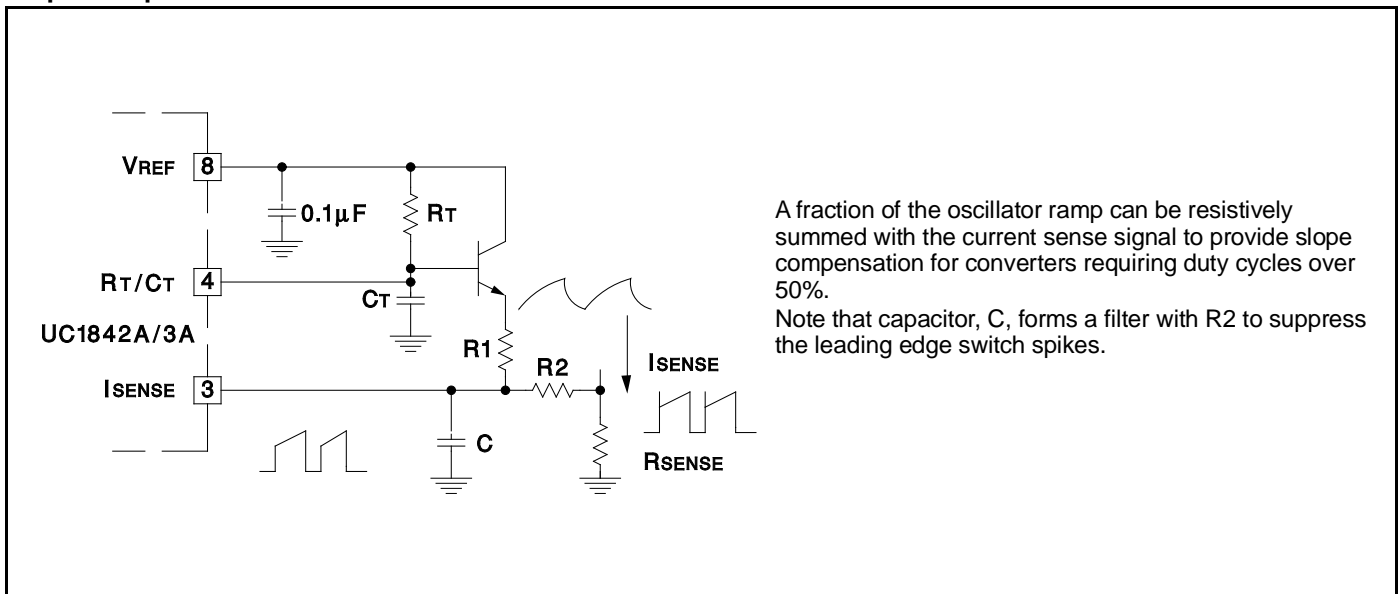

IMPORTANT NOTICE

Texas Instruments and its subsidiaries (TI) reserve the right to make changes to their products or to discontinue any product or service without notice, and advise customers to obtain the latest version of relevant information to verify, before placing orders, that information being relied on is current and complete. All products are sold subject to the terms and conditions of sale supplied at the time of order acknowledgement, including those pertaining to warranty, patent infringement, and limitation of liability.

TI warrants performance of its semiconductor products to the specifications applicable at the time of sale in accordance with TI's standard warranty. Testing and other quality control techniques are utilized to the extent TI deems necessary to support this warranty. Specific testing of all parameters of each device is not necessarily performed, except those mandated by government requirements.

CERTAIN APPLICATIONS USING SEMICONDUCTOR PRODUCTS MAY INVOLVE POTENTIAL RISKS OF DEATH, PERSONAL INJURY, OR SEVERE PROPERTY OR ENVIRONMENTAL DAMAGE ("CRITICAL APPLICATIONS"). TI SEMICONDUCTOR PRODUCTS ARE NOT DESIGNED, AUTHORIZED, OR WARRANTED TO BE SUITABLE FOR USE IN LIFE-SUPPORT DEVICES OR SYSTEMS OR OTHER CRITICAL APPLICATIONS. INCLUSION OF TI PRODUCTS IN SUCH APPLICATIONS IS UNDERSTOOD TO BE FULLY AT THE CUSTOMER'S RISK.

In order to minimize risks associated with the customer's applications, adequate design and operating safeguards must be provided by the customer to minimize inherent or procedural hazards.

TI assumes no liability for applications assistance or customer product design. TI does not warrant or represent that any license, either express or implied, is granted under any patent right, copyright, mask work right, or other intellectual property right of TI covering or relating to any combination, machine, or process in which such semiconductor products or services might be or are used. TI's publication of information regarding any third party's products or services does not constitute TI's approval, warranty or endorsement thereof.