

# TLC139, TLC339, TLC339Q LinCMOS™ MICROPOWER QUAD COMPARATORS

SLCS119A – DECEMBER 1986 – REVISED APRIL 2004

- Very Low Power . . . 200  $\mu$ W Typ at 5 V
- Fast Response Time . . . 2.5  $\mu$ s Typ With 5-mV Overdrive
- Single Supply Operation:
  - TLC139M . . . 4 V to 16 V
  - TLC339M . . . 4 V to 16 V
  - TLC339C . . . 3 V to 16 V
  - TLC339I . . . 3 V to 16 V
- High Input Impedance . . .  $10^{12}$   $\Omega$  Typ
- Input Offset Voltage Change at Worst Case Input at Condition Typically 0.23  $\mu$ V/Month Including the First 30 Days
- On-Chip ESD Protection

## description

The TLC139/TLC339 consists of four independent differential-voltage comparators designed to operate from a single supply. It is functionally similar to the LM139/LM339 family but uses 1/20th the power for similar response times. The open-drain MOS output stage interfaces to a variety of leads and supplies, as well as wired logic functions. For a similar device with a push-pull output configuration, see the TLC3704 data sheet.

The Texas Instruments LinCMOS™ process offers superior analog performance to standard CMOS processes. Along with the standard CMOS advantages of low power without sacrificing speed, high input impedance, and low bias currents, the LinCMOS™ process offers extremely stable input offset voltages, even with differential input stresses of several volts. This characteristic makes it possible to build reliable CMOS comparators.

D, J, N, OR PW PACKAGE  
(TOP VIEW)

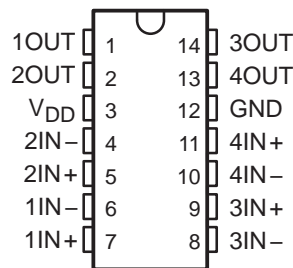

FK PACKAGE  
(TOP VIEW)

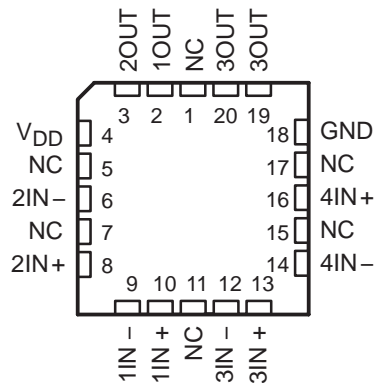

NC – No internal connection

## symbol (each comparator)



## AVAILABLE OPTIONS

T <sub>A</sub>	V <sub>IO</sub> max AT 25°C	PACKAGE				
		SMALL OUTLINE (D)	CHIP CARRIER (FK)	CERAMIC DIP (J)	PLASTIC DIP (P)	TSSOP (PW)
0°C to 70°C	5 mV	TLC339CD	—	—	TLC339CN	TLC339CPW
-40°C to 85°C	5 mV	TLC339ID	—	—	TLC339IN	—
-40°C to 125°C	5 mV	TLC339QD	—	—	TLC339QN	—
-55°C to 125°C	5 mV	TLC339MD	TLC139MFK	TLC139MJ	TLC339MN	—

The D and PW packages are available taped and reeled. Add the suffix R to the device type (e.g., TLC339CDR or TLC339CPWR).

LinCMOS is a trademark of Texas Instruments Incorporated.

PRODUCTION DATA information is current as of publication date. Products conform to specifications per the terms of Texas Instruments standard warranty. Production processing does not necessarily include testing of all parameters.



Copyright © 1991–2004, Texas Instruments Incorporated

# TLC139, TLC339, TLC339Q LinCMOS™ MICROPOWER QUAD COMPARATORS

SLCS119A – DECEMBER 1986 – REVISED APRIL 2004

## description (continued)

The TLC139M and TLC339M are characterized for operation over the full military temperature range of  $-55^{\circ}\text{C}$  to  $125^{\circ}\text{C}$ . The TLC339C is characterized for operation over the commercial temperature range of  $0^{\circ}\text{C}$  to  $70^{\circ}\text{C}$ . The TLC339I is characterized for operation over the industrial temperature range of  $-40^{\circ}\text{C}$  to  $85^{\circ}\text{C}$ . The TLC339Q is characterized for operation over the extended industrial temperature range of  $-40^{\circ}\text{C}$  to  $125^{\circ}\text{C}$ .

## output schematic

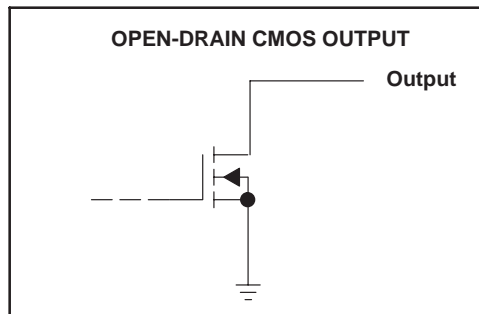

## absolute maximum ratings over operating free-air temperature range (unless otherwise noted)†

Supply voltage range, $V_{DD}$ (see Note 1)	$-0.3\text{ V to }18\text{ V}$
Differential input voltage, $V_{ID}$ (see Note 2)	$\pm 18\text{ V}$
Input voltage range, $V_I$	$-0.3\text{ V to }V_{DD}$
Output voltage range, $V_O$	$-0.3\text{ V to }V_{DD}$
Input current, $I_I$	$\pm 5\text{ mA}$
Output current, $I_O$ (each output)	$20\text{ mA}$
Total supply current into $V_{DD}$	$40\text{ mA}$
Total current out of GND	$60\text{ mA}$
Continuous total dissipation	See Dissipation Rating Table
Operating free-air temperature range, $T_A$ : TLC139M	$-55^{\circ}\text{C to }125^{\circ}\text{C}$
TLC339C	$0^{\circ}\text{C to }70^{\circ}\text{C}$
TLC339I	$-40^{\circ}\text{C to }85^{\circ}\text{C}$
TLC339M	$-55^{\circ}\text{C to }125^{\circ}\text{C}$
TLC339Q	$-40^{\circ}\text{C to }125^{\circ}\text{C}$
Storage temperature range	$-65^{\circ}\text{C to }150^{\circ}\text{C}$
Case temperature for 60 seconds: FK package	$260^{\circ}\text{C}$
Lead temperature 1,6 mm (1/16 inch) from case for 10 seconds: D or N package	$260^{\circ}\text{C}$
Lead temperature 1,6 mm (1/16 inch) from case for 60 seconds: J package	$300^{\circ}\text{C}$

† Stresses beyond those listed under “absolute maximum ratings” may cause permanent damage to the device. These are stress ratings only, and functional operation of the device at these or any other conditions beyond those indicated under “recommended operating conditions” is not implied. Exposure to absolute-maximum-rated conditions for extended periods may affect device reliability.

- NOTES: 1. All voltage values, except differential voltages, are with respect to network ground.  
2. Differential voltages are at  $IN+$  with respect to  $IN-$ .

DISSIPATION RATING TABLE

PACKAGE	$T_A \leq 25^{\circ}\text{C}$ POWER RATING	DERATING FACTOR ABOVE $T_A = 25^{\circ}\text{C}$	$T_A = 70^{\circ}\text{C}$ POWER RATING	$T_A = 85^{\circ}\text{C}$ POWER RATING	$T_A = 125^{\circ}\text{C}$ POWER RATING
D	950 mW	7.6 mW/ $^{\circ}\text{C}$	608 mW	494 mW	190 mW
FK	1375 mW	11.0 mW/ $^{\circ}\text{C}$	880 mW	715 mW	275 mW
J	1375 mW	11.0 mW/ $^{\circ}\text{C}$	880 mW	715 mW	275 mW
N	1150 mW	9.2 mW/ $^{\circ}\text{C}$	736 mW	598 mW	230 mW
PW	700 mW	5.6 mW/ $^{\circ}\text{C}$	448 mW	364 mW	140 mW

# TLC139, TLC339, TLC339Q

## LinCMOS™ MICROPOWER QUAD COMPARATORS

SLCS119A – DECEMBER 1986 – REVISED APRIL 2004

### recommended operating conditions

	TLC139M, TLC339M			UNIT
	MIN	NOM	MAX	
Supply voltage, $V_{DD}$	4	5	16	V
Common-mode input voltage, $V_{IC}$	0		$V_{DD} - 1.5$	V
Low-level output current, $I_{OL}$			20	mA
Operating free-air temperature, $T_A$	-55		125	°C

### electrical characteristics at specified operating free-air temperature, $V_{DD} = 5$ V (unless otherwise noted)

PARAMETER	TEST CONDITIONS†	$T_A$	TLC139M, TLC339M			UNIT
			MIN	TYP	MAX	
$V_{IO}$ Input offset voltage	$V_{IC} = V_{ICRmin}$ , See Note 3	25°C		1.4	5	mV
		-55°C to 125°C			10	
$I_{IO}$ Input offset current	$V_{IC} = 2.5$ V	25°C		1		pA
		125°C			15	nA
$I_{IB}$ Input bias current	$V_{IC} = 2.5$ V	25°C		5		pA
		125°C			30	nA
$V_{ICR}$ Common-mode input voltage range		25°C	0 to $V_{DD} - 1$		V	
		-55°C to 125°C	0 to $V_{DD} - 1.5$			
CMRR Common-mode rejection ratio	$V_{IC} = V_{ICRmin}$	25°C	84		dB	
		125°C	84			
		-55°C	84			
$k_{SVR}$ Supply-voltage rejection ratio	$V_{DD} = 5$ V to 10 V	25°C	85		dB	
		125°C	84			
		-55°C	84			
$V_{OL}$ Low-level output voltage	$V_{ID} = -1$ V, $I_{OL} = 6$ mA	25°C	300	400	mV	
		125°C	800			
$I_{OH}$ High-level output current	$V_{ID} = -1$ V, $V_O = 5$ V	25°C	0.8	40	nA	
		125°C	1		μA	
$I_{DD}$ Supply current (four comparators)	Outputs low, No load	25°C	44	80	μA	
		-55°C to 125°C	175			

† All characteristics are measured with zero common-mode voltage unless otherwise noted.

NOTE 3: The offset voltage limits given are the maximum values required to drive the output up to 4.5 V or down to 0.3 V with a 2.5-kΩ load to  $V_{DD}$ .

# TLC139, TLC339, TLC339Q

## LinCMOS™ MICROPOWER QUAD COMPARATORS

SLCS119A – DECEMBER 1986 – REVISED APRIL 2004

### recommended operating conditions

	TLC339C			UNIT
	MIN	NOM	MAX	
Supply voltage, $V_{DD}$	3	5	16	V
Common-mode input voltage, $V_{IC}$	-0.2		$V_{DD}-1.5$	V
Low-level output current, $I_{OL}$		8	20	mA
Operating free-air temperature, $T_A$	0		70	°C

### electrical characteristics at specified operating free-air temperature, $V_{DD} = 5$ V (unless otherwise noted)

PARAMETER	TEST CONDITION†	$T_A$	TLC339C			UNIT
			MIN	TYP	MAX	
$V_{IO}$ Input offset voltage	$V_{IC} = V_{ICRmin}$ , See Note 3	25°C		1.4	5	mV
		0°C to 70°C			6.5	
$I_{IO}$ Input offset current	$V_{IC} = 2.5$ V	25°C		1		pA
		70°C			0.3	nA
$I_{IB}$ Input bias current	$V_{IC} = 2.5$ V	25°C		5		pA
		70°C			0.6	nA
$V_{ICR}$ Common-mode input voltage range		25°C		0 to $V_{DD}-1$		V
		0°C to 70°C		0 to $V_{DD}-1.5$		
CMRR Common-mode rejection ratio	$V_{IC} = V_{ICRmin}$	25°C		84		dB
		70°C		84		
		0°C		84		
$k_{SVR}$ Supply-voltage rejection ratio	$V_{DD} = 5$ V to 10 V	25°C		85		dB
		70°C		85		
		0°C		85		
$V_{OL}$ Low-level output voltage	$V_{ID} = -1$ V, $I_{OL} = 6$ mA	25°C		300	400	mV
		70°C			650	
$I_{OH}$ High-level output current	$V_{ID} = -1$ V, $V_O = 5$ V	25°C		0.8	40	nA
		70°C			1	μA
$I_{DD}$ Supply current (four comparators)	Outputs low, No load	25°C		44	80	μA
		0°C to 70°C			100	

† All characteristics are measured with zero common-mode voltage unless otherwise noted.

NOTE 4: The offset voltage limits given are the maximum values required to drive the output up to 4.5 V or down to 0.3 V with a 2.5-kΩ load to  $V_{DD}$ .

# TLC139, TLC339, TLC339Q

## LinCMOS™ MICROPOWER QUAD COMPARATORS

SLCS119A – DECEMBER 1986 – REVISED APRIL 2004

### recommended operating conditions

	TLC339I			UNIT
	MIN	NOM	MAX	
Supply voltage, $V_{DD}$	3	5	16	V
Common-mode input voltage, $V_{IC}$	-0.2		$V_{DD}-1.5$	V
Low-level output current, $I_{OL}$		8	20	mA
Operating free-air temperature, $T_A$	0		70	°C

### electrical characteristics at specified operating free-air temperature, $V_{DD} = 5\text{ V}$ (unless otherwise noted)

PARAMETER	TEST CONDITIONST	$T_A$	TLC339I			UNIT
			MIN	TYP	MAX	
$V_{IO}$ Input offset voltage	$V_{IC} = V_{ICRmin}$ , See Note 3	25°C		1.4	5	mV
		-40°C to 85°C			7	
$I_{IO}$ Input offset current	$V_{IC} = 2.5\text{ V}$	25°C		1		pA
		85°C			1	nA
$I_{IB}$ Input bias current	$V_{IC} = 2.5\text{ V}$	25°C		5		pA
		85°C			2	nA
$V_{ICR}$ Common-mode input voltage range		25°C	0 to $V_{DD}-1$		V	
		-40°C to 85°C	0 to $V_{DD}-1.5$			
CMRR Common-mode rejection ratio	$V_{IC} = V_{ICRmin}$	25°C	84		dB	
		85°C	84			
		-40°C	84			
$k_{SVR}$ Supply-voltage rejection ratio	$V_{DD} = 5\text{ V to }10\text{ V}$	25°C	85		dB	
		85°C	85			
		-40°C	84			
$V_{OL}$ Low-level output voltage	$V_{ID} = -1\text{ V}$ , $I_{OL} = 6\text{ mA}$	25°C	300	400	mV	
		85°C	700			
$I_{OH}$ High-level output current	$V_{ID} = -1\text{ V}$ , $V_O = 5\text{ V}$	25°C	0.8	40	nA	
		85°C	1		μA	
$I_{DD}$ Supply current (four comparators)	Outputs low, No load	25°C	44	80	μA	
		-40°C to 85°C	125			

† All characteristics are measured with zero common-mode voltage unless otherwise noted.

NOTE 3: The offset voltage limits given are the maximum values required to drive the output up to 4.5 V or down to 0.3 V with a 2.5-kΩ load to  $V_{DD}$ .

# TLC139, TLC339, TLC339Q

## LinCMOS™ MICROPOWER QUAD COMPARATORS

SLCS119A – DECEMBER 1986 – REVISED APRIL 2004

### recommended operating conditions

	TLC339Q			UNIT
	MIN	NOM	MAX	
Supply voltage, $V_{DD}$	4	5	16	V
Common-mode input voltage, $V_{IC}$	0		$V_{DD}-1.5$	V
Low-level output current, $I_{OL}$			20	mA
Operating free-air temperature, $T_A$	-40		125	°C

### electrical characteristics at specified operating free-air temperature, $V_{DD} = 5\text{ V}$ (unless otherwise noted)

PARAMETER	TEST CONDITIONS†	$T_A$	TLC339Q			UNIT
			MIN	TYP	MAX	
$V_{IO}$ Input offset voltage	$V_{IC} = V_{ICRmin}$ , See Note 3	25°C		1.4	5	mV
		-40°C to 125°C			10	
$I_{IO}$ Input offset current	$V_{IC} = 2.5\text{ V}$	25°C		1		pA
		125°C			15	nA
$I_{IB}$ Input bias current	$V_{IC} = 2.5\text{ V}$	25°C		5		pA
		125°C			30	nA
$V_{ICR}$ Common-mode input voltage range		25°C		0 to $V_{DD}-1$		V
		-40°C to 125°C		0 to $V_{DD}-1.5$		
CMRR Common-mode rejection ratio	$V_{IC} = V_{ICRmin}$	25°C		84		dB
		125°C		84		
		-40°C		84		
$k_{SVR}$ Supply-voltage rejection ratio	$V_{DD} = 5\text{ V to }10\text{ V}$	25°C		85		dB
		125°C		84		
		-40°C		84		
$V_{OL}$ Low-level output voltage	$V_{ID} = -1\text{ V}$ , $I_{OL} = 6\text{ mA}$	25°C		300	400	mV
		125°C			800	
$I_{OH}$ High-level output current	$V_{ID} = -1\text{ V}$ , $V_O = 5\text{ V}$	25°C		0.8	40	nA
		125°C			1	μA
$I_{DD}$ Supply current (four comparators)	Outputs low, No load	25°C		44	80	μA
		-40°C to 125°C			125	

† All characteristics are measured with zero common-mode voltage unless otherwise noted.

NOTE 4: The offset voltage limits given are the maximum values required to drive the output up to 4.5 V or down to 0.3 V with a 2.5-kΩ load to  $V_{DD}$ .

switching characteristics,  $V_{DD} = 5\text{ V}$ ,  $T_A = 25^\circ\text{C}$  (see Figure 3)

PARAMETER	TEST CONDITIONS	TLC139M, TLC339C TLC339I, TLC339M TLC339Q			UNIT
		MIN	TYP	MAX	
$t_{PLH}$ Propagation delay time, low-to-high output	$f = 10\text{ kHz}$ , $C_L = 15\text{ pF}$	Overdrive = 2 mV	4.5		$\mu\text{s}$
		Overdrive = 5 mV	2.5		
		Overdrive = 10 mV	1.7		
		Overdrive = 20 mV	1.2		
		Overdrive = 40 mV	1.0		
	$V_I = 1.4\text{ V}$ step at $IN+$	1.1			
$t_{PHL}$ Propagation delay time, high-to-low level output	$f = 10\text{ kHz}$ , $C_L = 15\text{ pF}$	Overdrive = 2 mV	3.6		$\mu\text{s}$
		Overdrive = 5 mV	2.1		
		Overdrive = 10 mV	1.3		
		Overdrive = 20 mV	0.85		
		Overdrive = 40 mV	0.55		
	$V_I = 1.4\text{ V}$ step at $IN+$	0.10			
$t_{THL}$ Transition time, high-to-low level output	$f = 10\text{ kHz}$ , $C_L = 15\text{ pF}$	Overdrive = 50 mV	20		ns

### PARAMETER MEASUREMENT INFORMATION

The TLC139 and TLC339 contain a digital output stage that, if held in the linear region of the transfer curve, can cause damage to the device. Conventional operational amplifier/comparator testing incorporates the use of a servo-loop that is designed to force the device output to a level within this linear region. Since the servo-loop method of testing cannot be used, the following alternatives for testing parameters such as input offset voltage, common-mode rejection, etc., are suggested.

To verify that the input offset voltage falls within the limits specified, the limit value is applied to the input as shown in Figure 1(a). With the noninverting input positive with respect to the inverting input, the output should be high. With the input polarity reversed, the output should be low.

A similar test can be made to verify the input offset voltage at the common-mode extremes. The supply voltages can be slewed as shown in Figure 1(b) for the  $V_{ICR}$  test, rather than changing the input voltages, to provide greater accuracy.

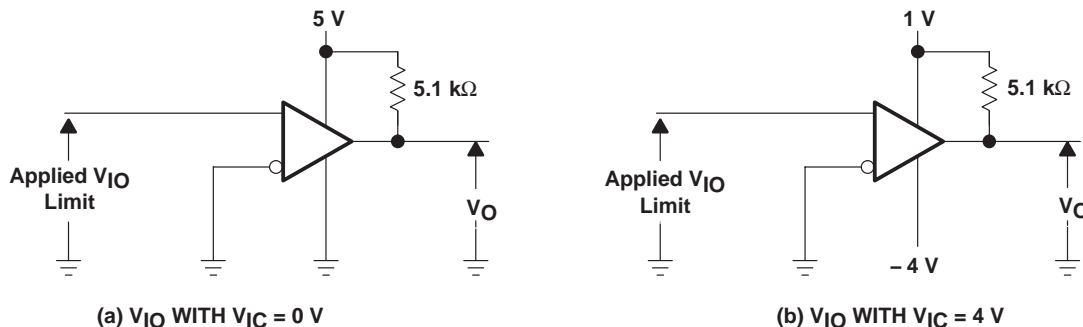

**Figure 1. Method for Verifying That Input Offset Voltage Is Within Specified Limits**

**PARAMETER MEASUREMENT INFORMATION**

A close approximation of the input offset voltage can be obtained by using a binary search method to vary the differential input voltage while monitoring the output state. When the applied input voltage differential is equal but opposite in polarity to the input offset voltage, the output changes state.

Figure 2 illustrates a practical circuit for direct dc measurement of input offset voltage that does not bias the comparator into the linear region. The circuit consists of a switching mode servo loop in which U1A generates a triangular waveform of approximately 20-mV amplitude. U1B acts as a buffer, with C2 and R4 removing any residual dc offset. The signal is then applied to the inverting input of the comparator under test, while the noninverting input is driven by the output of the integrator formed by U1C through the voltage divider formed by R9 and R10. The loop reaches a stable operating point when the output of the comparator under test has a duty cycle of exactly 50%, which can only occur when the incoming triangle wave is sliced symmetrically or when the voltage at the noninverting input exactly equals the input offset voltage.

Voltage divider R9 and R10 provides a step-up of the input offset voltage by a factor of 100 to make measurement easier. The values of R5, R8, R9, and R10 can significantly influence the accuracy of the reading; therefore, it is suggested that their tolerance level be 1% or lower.

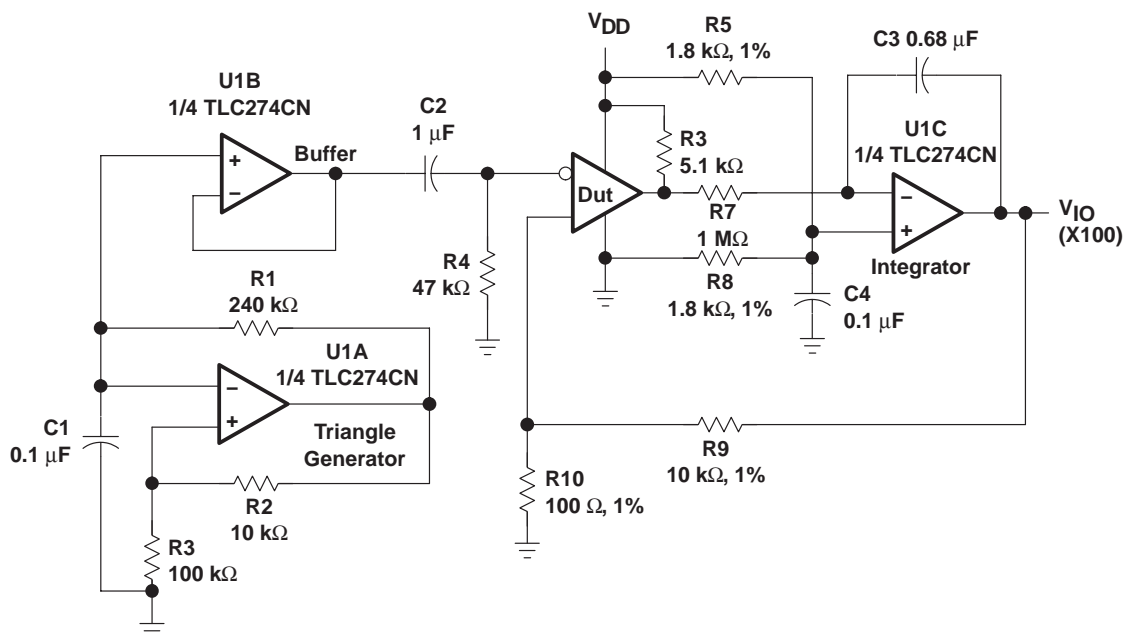
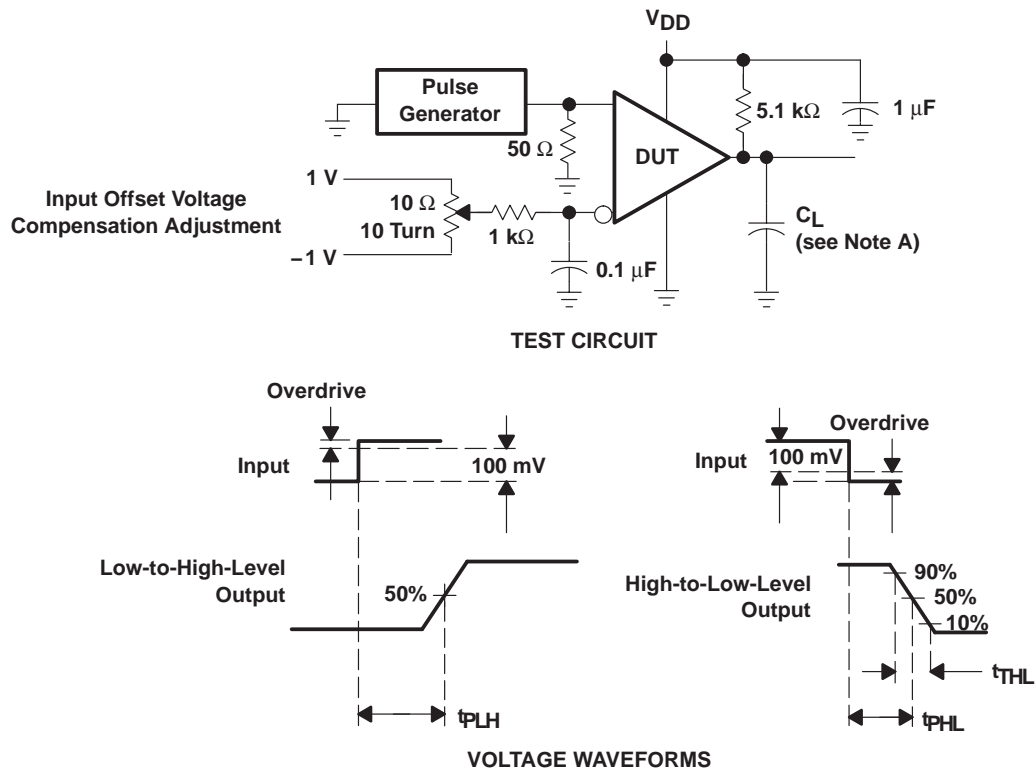

**Figure 2. Circuit for Input Offset Voltage Measurement**

Measuring the extremely low values of input current requires isolation from all other sources of leakage current and compensation for the leakage of the test socket and board. With a good picoammeter, the socket and board leakage can be measured with no device in the socket. Subsequently, this open socket leakage value can be subtracted from the measurement obtained, with a device in the socket to obtain the actual input current of the device.

**PARAMETER MEASUREMENT INFORMATION**

Propagation delay time is defined as the interval between the application of an input step function and the instant when the output reaches 50% of its maximum value. Propagation delay time, low-to-high-level output, is measured from the leading edge of the input pulse, while propagation delay time, high-to-low-level output, is measured from the trailing edge of the input pulse. Propagation delay time measurement at low input signal levels can be greatly affected by the input offset voltage. The offset voltage should be balanced by the adjustment at the inverting input as shown in Figure 3, so that the circuit is just at the transition point. Then a low signal, for example 105-mV or 5-mV overdrive, causes the output to change state.



NOTE A:  $C_L$  includes probe and jig capacitance.

**Figure 3. Propagation Delay, Rise, and Fall Times Test Circuit and Voltage Waveforms**

**TLC139, TLC339, TLC339Q**  
**LinCMOS™ MICROPPOWER QUAD COMPARATORS**

SLCS119A – DECEMBER 1986 – REVISED APRIL 2004

**TYPICAL CHARACTERISTICS**

Table of Graphs

			FIGURE
$V_{IO}$	Input offset voltage	Distribution	4
$I_{IB}$	Input bias current	vs Free-air temperature	5
CMRR	Common-mode rejection ratio	vs Free-air temperature	6
$k_{SVR}$	Supply-voltage rejection ratio	vs Free-air temperature	7
$I_{OH}$	High-level output current	vs High-level output voltage	8
		vs Free-air temperature	9
$V_{OL}$	Low-level output voltage	vs Low-level output current	10
		vs Free-air temperature	11
$I_{DD}$	Supply current	vs Supply voltage	12
		vs Free-air temperature	13
$t_{PLH}$	Low-to-high level output propagation delay time	vs Supply voltage	14
$t_{PHL}$	Low-to-high level output propagation delay time	vs Supply voltage	15
		Overdrive voltage	16
$t_f$	Output fall time	vs Supply voltage	17
		Overdrive voltage	18

**TYPICAL CHARACTERISTICS†**

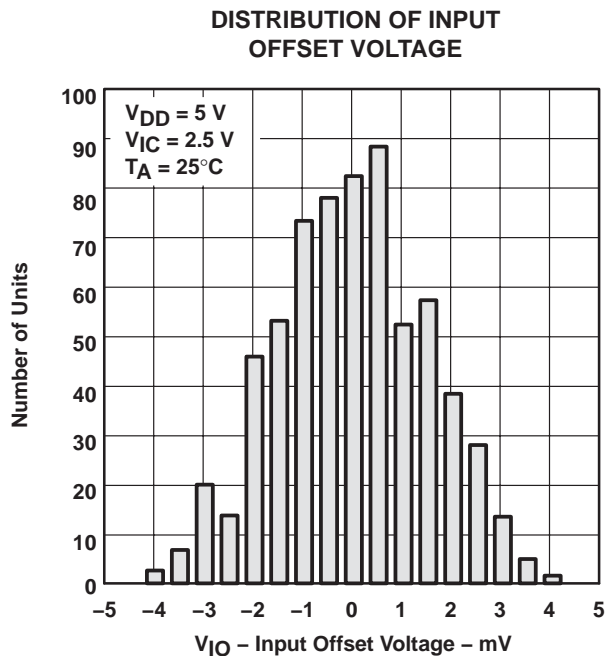

**Figure 4**

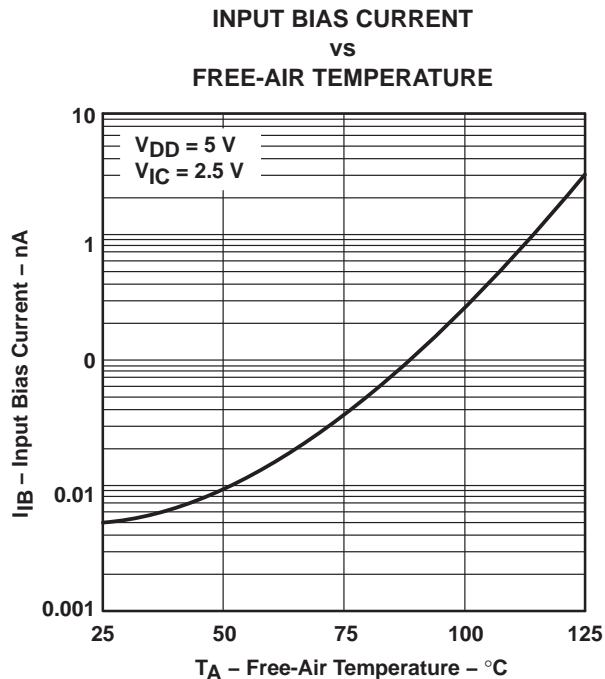

**Figure 5**

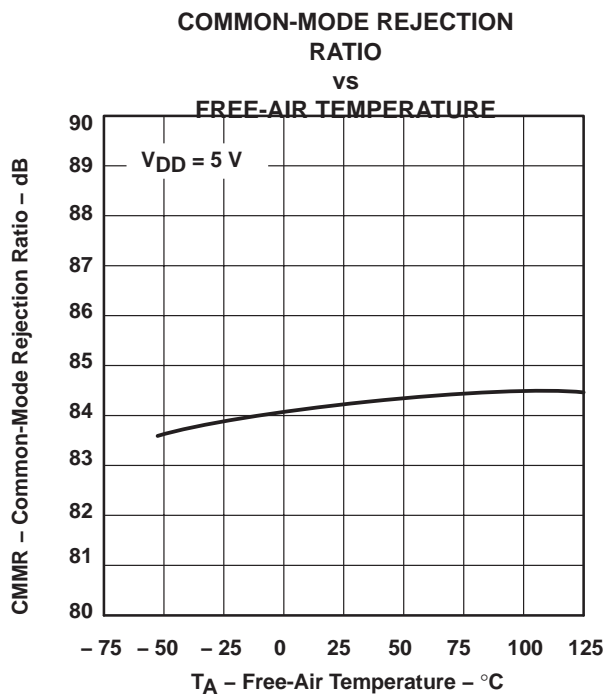

**Figure 6**

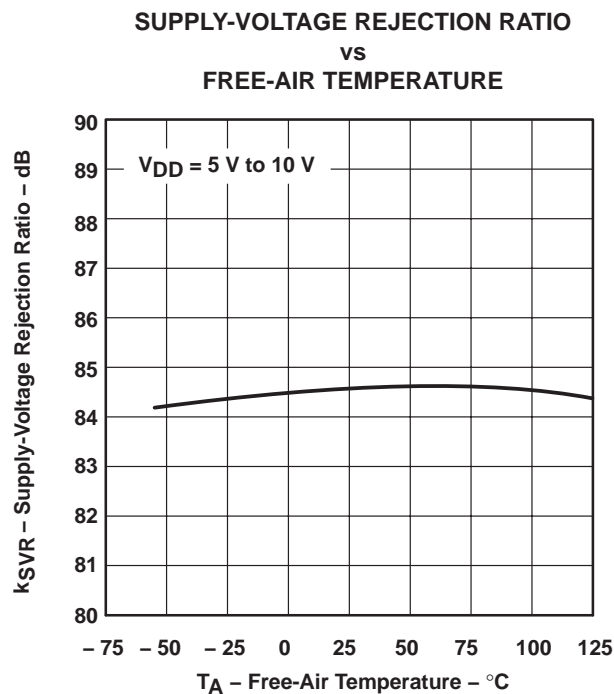
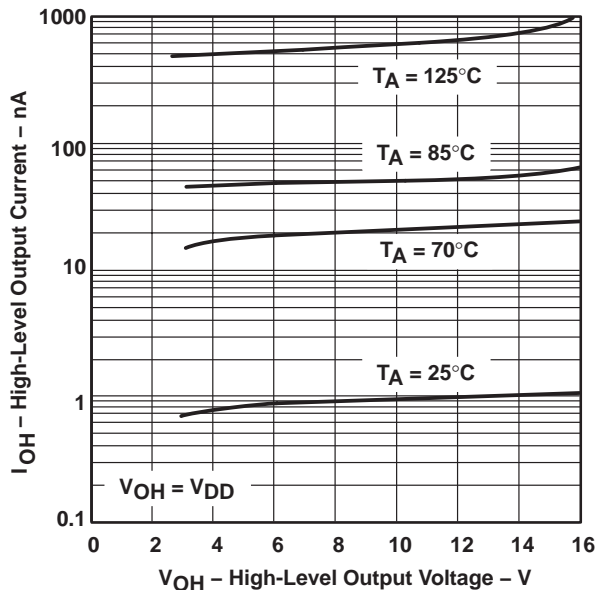

**Figure 7**

† Data at high and low temperatures are applicable only within the rated operating free-air temperature ranges of the various devices.

**TYPICAL CHARACTERISTICS†**

**HIGH-LEVEL OUTPUT CURRENT  
 vs  
 HIGH-LEVEL OUTPUT VOLTAGE**



**Figure 8**

**HIGH-LEVEL OUTPUT CURRENT  
 vs  
 FREE-AIR TEMPERATURE**

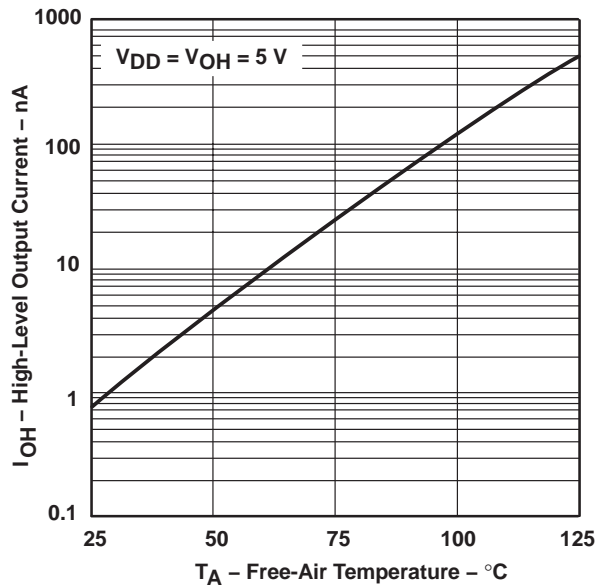

**Figure 9**

**LOW-LEVEL OUTPUT VOLTAGE  
 vs  
 LOW-LEVEL OUTPUT CURRENT**

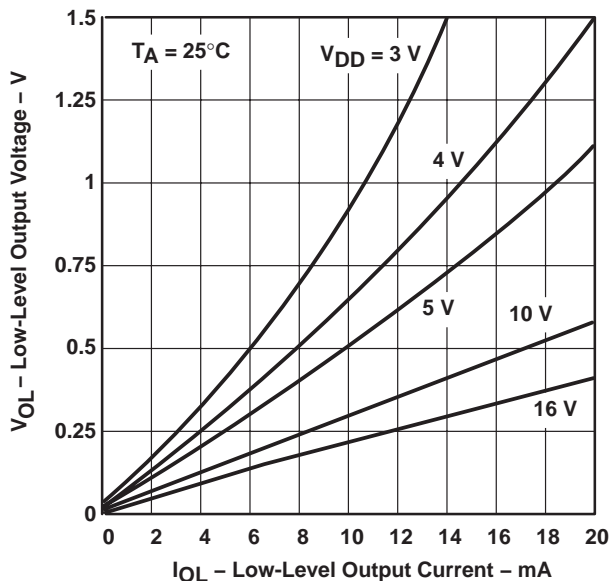

**Figure 10**

**LOW-LEVEL OUTPUT VOLTAGE  
 vs  
 FREE-AIR TEMPERATURE**

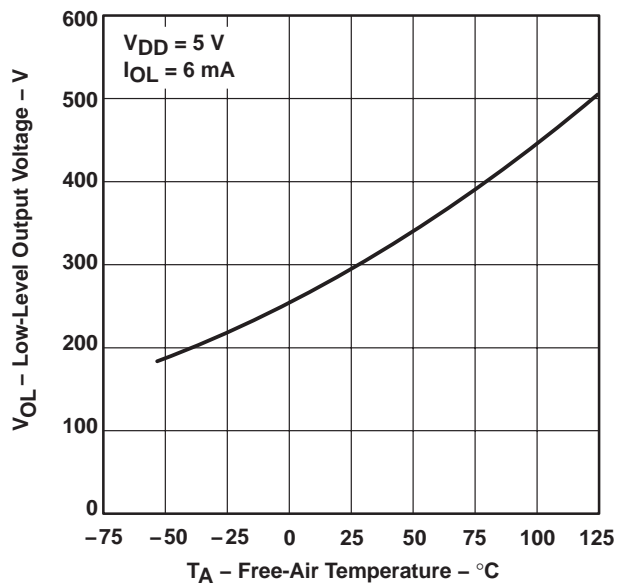

**Figure 11**

† Data at high and low temperatures are applicable only within the rated operating free-air temperature ranges of the various devices.

TYPICAL CHARACTERISTICS†

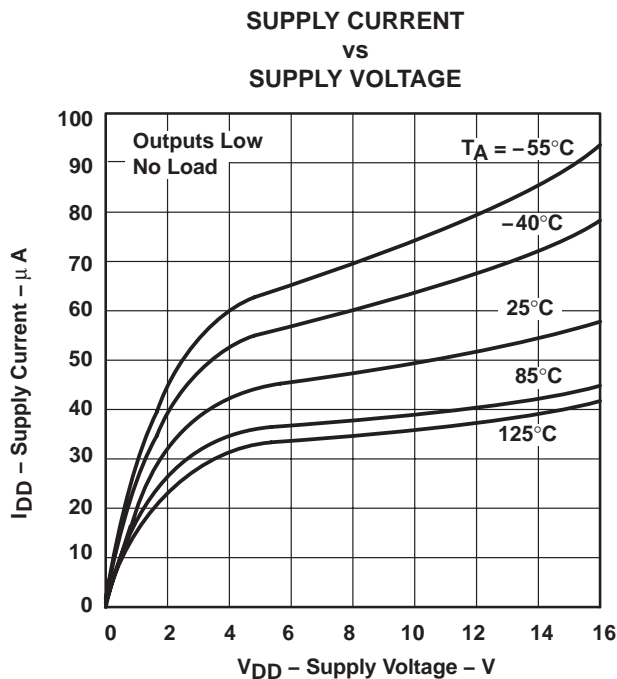

Figure 12

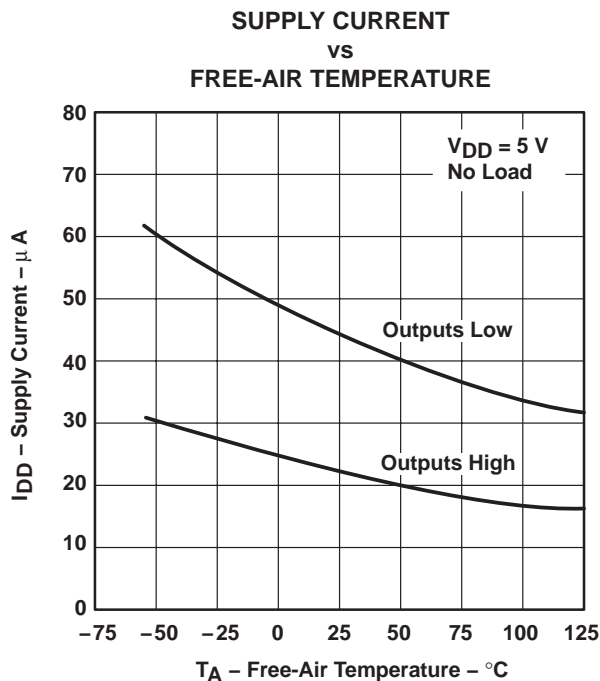

Figure 13

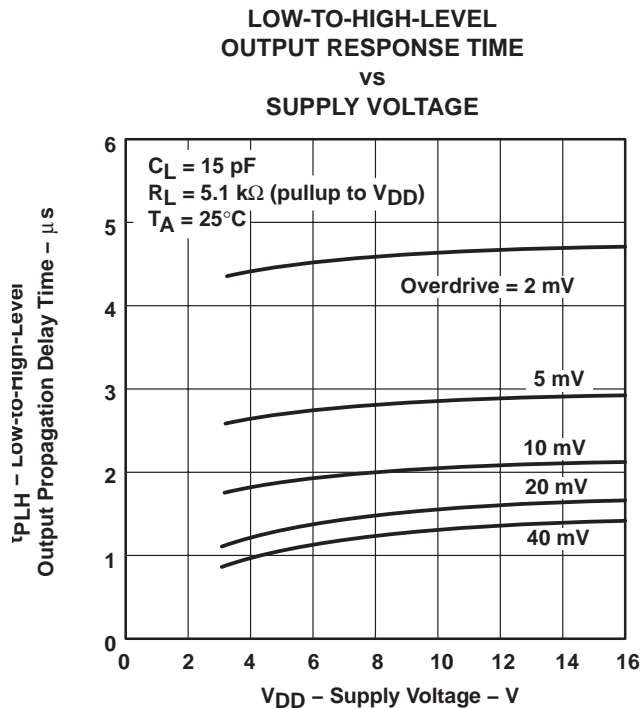

Figure 14

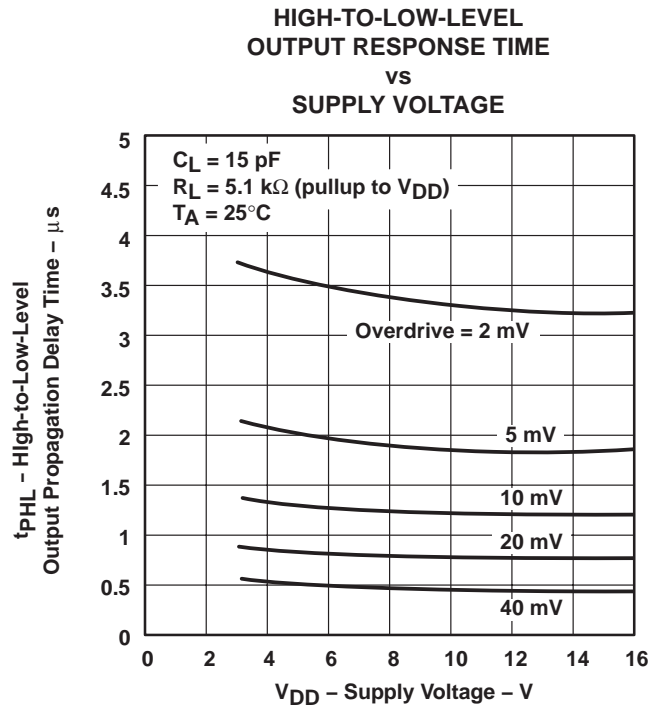
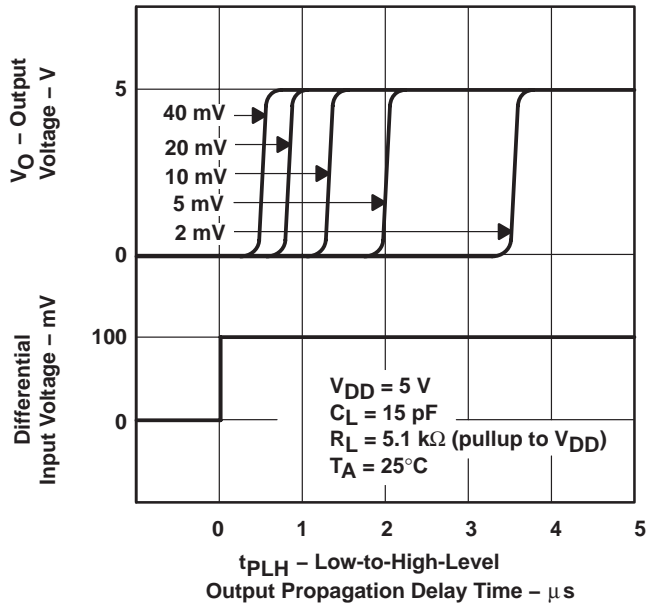

Figure 15

† Data at high and low temperatures are applicable only within the rated operating free-air temperature ranges of the various devices.

**TYPICAL CHARACTERISTICS**

**LOW-TO-HIGH-LEVEL OUTPUT PROPAGATION DELAY FOR VARIOUS OVERDRIVE VOLTAGES**



**Figure 16**

**OUTPUT FALL TIME vs SUPPLY VOLTAGE**

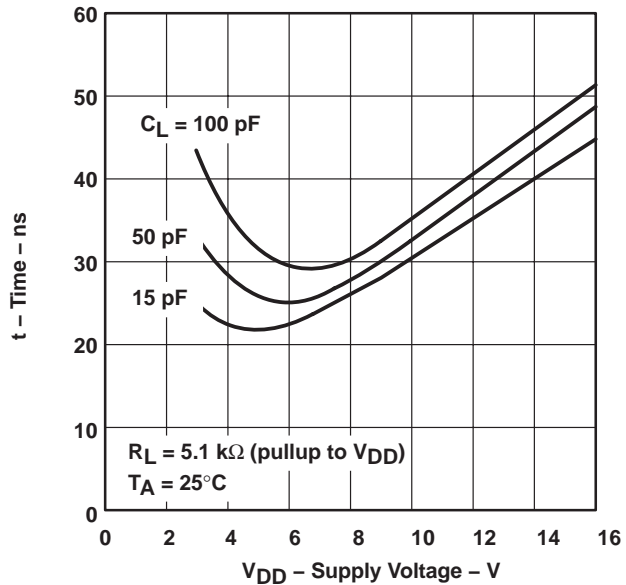

**Figure 17**

**HIGH-TO-LOW-LEVEL OUTPUT PROPAGATION DELAY FOR VARIOUS OVERDRIVE VOLTAGES**

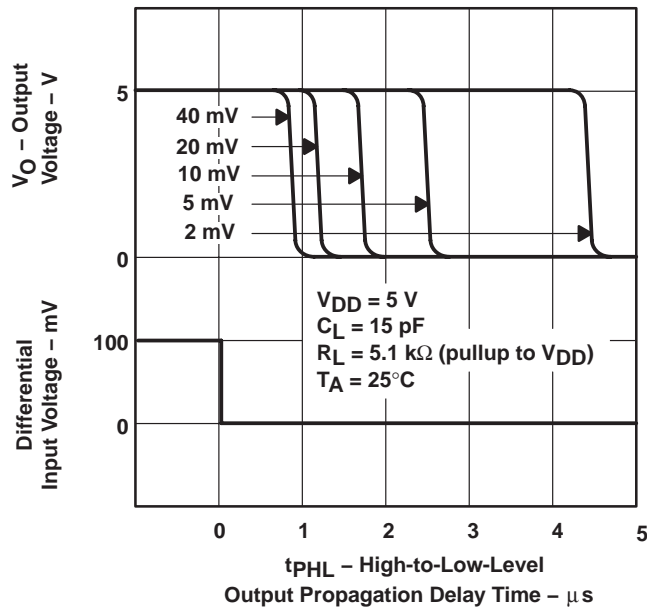

**Figure 18**

### APPLICATION INFORMATION

The inputs should always remain within the supply rails in order to avoid forward biasing the diodes in the electrostatic discharge (ESD) protection structure. If either input exceeds this range, the device is not damaged as long as the input current is limited to less than 5 mA. To maintain the expected output state, the inputs must remain within the common-mode range. For example, at 25°C with  $V_{DD} = 5\text{ V}$ , both inputs must remain between  $-0.2\text{ V}$  and  $4\text{ V}$  to assure proper device operation. To assure reliable operation, the supply should be decoupled with a capacitor ( $0.1\text{ }\mu\text{F}$ ) positioned as close to the device as possible.

The output and supply currents require close observation since the TLC139/TLC339 does not provide current protection. For example, each output can source or sink a maximum of 20 mA; however, the total current to ground has an absolute maximum of 60 mA. This prohibits sinking 20 mA from each of the four outputs simultaneously since the total current to ground would be 80 mA.

The TLC139 and TLC339 have internal ESD-protection circuits that prevent functional failures at voltages up to 2000 V as tested under MIL-STD-883C, Method 3015.2; however, exercise care when handling these devices as exposure to ESD may result in the degradation of the device parametric performance.

Table of Applications

	FIGURE
Pulse-width-modulated motor speed controller	19
Enhanced supply supervisor	20
Two-phase nonoverlapping clock generator	21

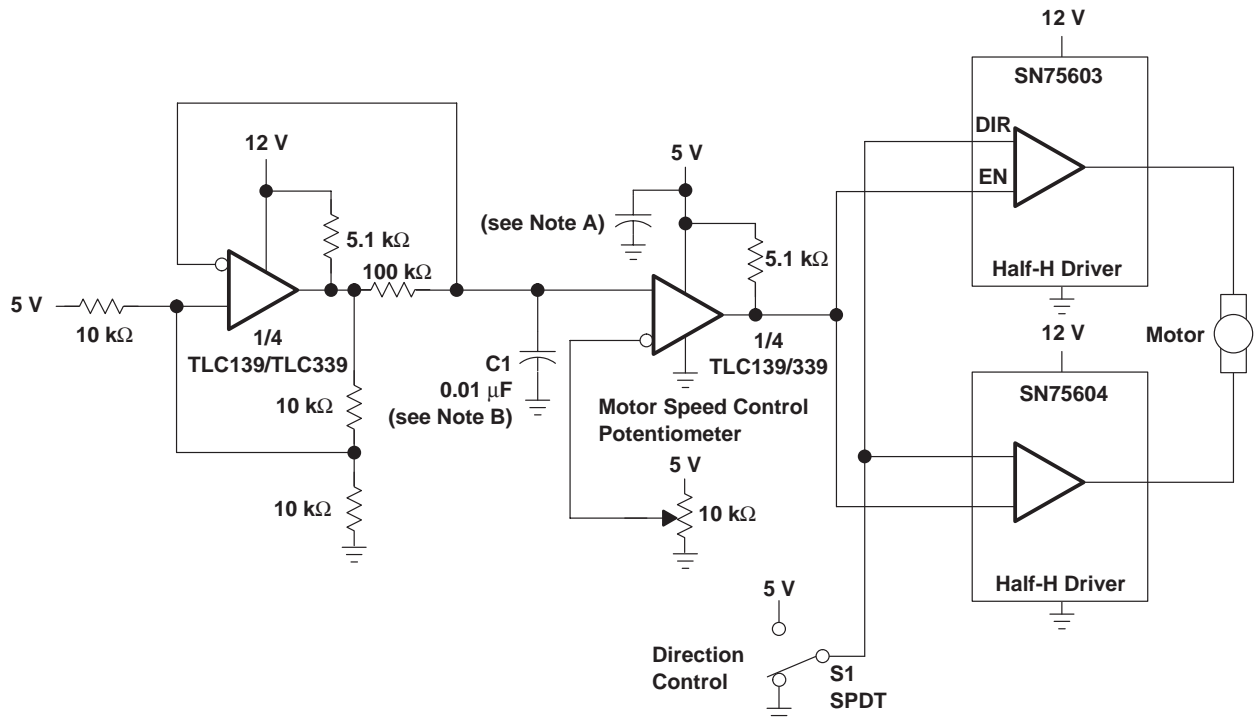

- NOTES: A. The recommended minimum capacitance is 10  $\mu\text{F}$  to eliminate common ground switching noise.  
 B. Select C1 for change in oscillator frequency.

**Figure 19. Pulse-Width-Modulated Motor Speed Controller**

# TLC139, TLC339, TLC339Q LinCMOS™ MICROPOWER QUAD COMPARATORS

SLCS119A – DECEMBER 1986 – REVISED APRIL 2004

## TYPICAL APPLICATION DATA

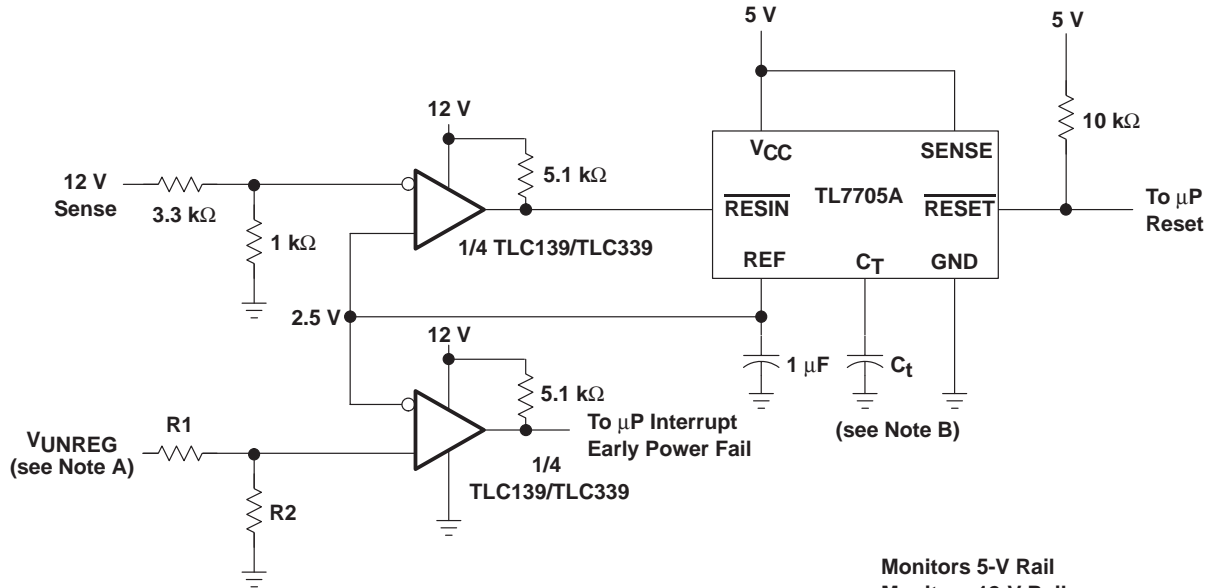

Monitors 5-V Rail  
Monitors 12-V Rail  
Early Power Fail Warning

NOTES: A.  $V_{UNREG} = 2.5 \left( \frac{R1 + R2}{R2} \right)$

B. The value of  $C_t$  determines the time delay of reset.

Figure 20. Enhanced Supply Supervisor

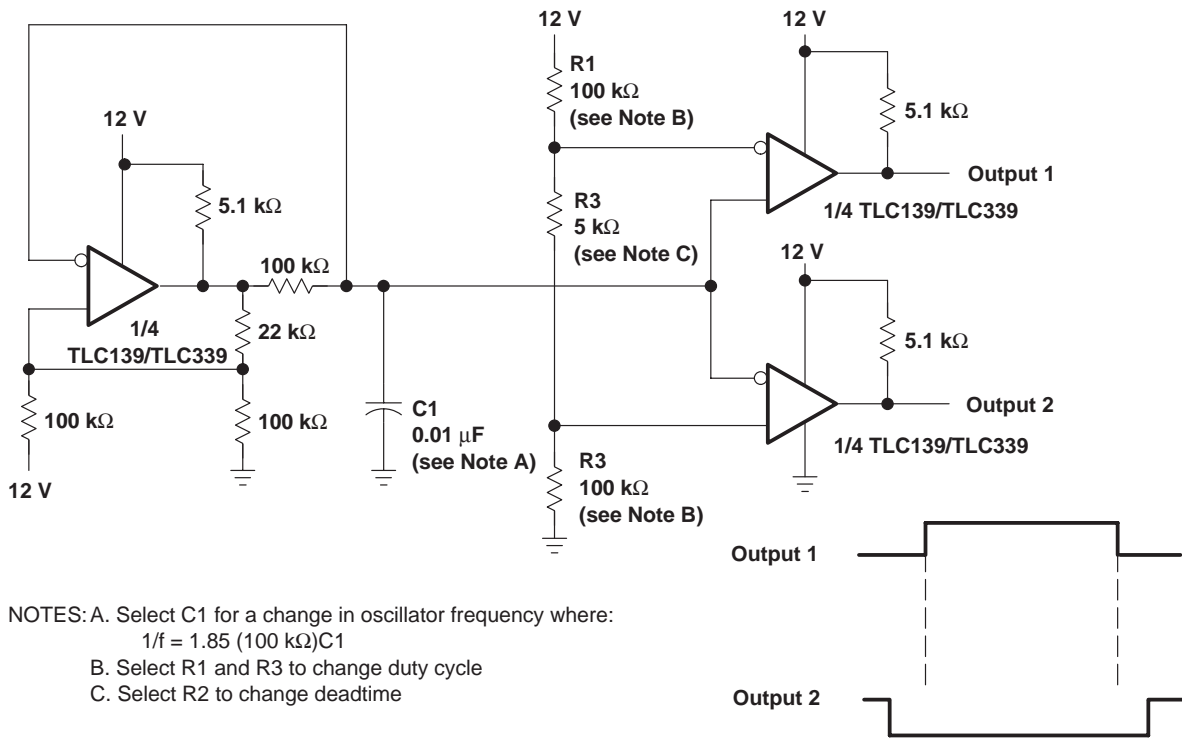

NOTES: A. Select  $C_1$  for a change in oscillator frequency where:  
 $1/f = 1.85 (100 \text{ k}\Omega) C_1$   
B. Select  $R_1$  and  $R_3$  to change duty cycle  
C. Select  $R_2$  to change deadtime

Figure 21. Two-Phase Nonoverlapping Clock Generator

**PACKAGING INFORMATION**

Orderable Device	Status <sup>(1)</sup>	Package Type	Package Drawing	Pins	Package Qty	Eco Plan <sup>(2)</sup>	Lead/Ball Finish	MSL Peak Temp <sup>(3)</sup>
5962-87659022A	ACTIVE	LCCC	FK	20	1	None	POST-PLATE	Level-NC-NC-NC
5962-8765902CA	ACTIVE	CDIP	J	14	1	None	A42 SNPB	Level-NC-NC-NC
5962-9555001NXDR	ACTIVE	SOIC	D	14	2500	None	CU NIPDAU	Level-1-220C-UNLIM
TLC139MFKB	ACTIVE	LCCC	FK	20	1	None	POST-PLATE	Level-NC-NC-NC
TLC139MJ	ACTIVE	CDIP	J	14	1	None	A42 SNPB	Level-NC-NC-NC
TLC139MJB	ACTIVE	CDIP	J	14	1	None	A42 SNPB	Level-NC-NC-NC
TLC339CD	ACTIVE	SOIC	D	14	50	Pb-Free (RoHS)	CU NIPDAU	Level-2-260C-1YEAR/ Level-1-220C-UNLIM
TLC339CDB	ACTIVE	SSOP	DB	14	80	Pb-Free (RoHS)	CU NIPDAU	Level-2-260C-1YEAR/ Level-1-220C-UNLIM
TLC339CDBR	ACTIVE	SSOP	DB	14	2000	Pb-Free (RoHS)	CU NIPDAU	Level-2-260C-1YEAR/ Level-1-220C-UNLIM
TLC339CDR	ACTIVE	SOIC	D	14	2500	Pb-Free (RoHS)	CU NIPDAU	Level-2-260C-1YEAR/ Level-1-220C-UNLIM
TLC339CN	ACTIVE	PDIP	N	14	25	Pb-Free (RoHS)	CU NIPDAU	Level-NC-NC-NC
TLC339CN10	OBSOLETE	PDIP	N	14		None	Call TI	Call TI
TLC339CNSR	ACTIVE	SO	NS	14	2000	Pb-Free (RoHS)	CU NIPDAU	Level-2-260C-1YEAR/ Level-1-220C-UNLIM
TLC339CPW	ACTIVE	TSSOP	PW	14	90	None	CU NIPDAU	Level-1-220C-UNLIM
TLC339CPWLE	OBSOLETE	TSSOP	PW	14		None	Call TI	Call TI
TLC339CPWR	ACTIVE	TSSOP	PW	14	2000	None	CU NIPDAU	Level-1-220C-UNLIM
TLC339ID	ACTIVE	SOIC	D	14	50	Pb-Free (RoHS)	CU NIPDAU	Level-2-260C-1YEAR/ Level-1-220C-UNLIM
TLC339IDR	ACTIVE	SOIC	D	14	2500	Pb-Free (RoHS)	CU NIPDAU	Level-2-260C-1YEAR/ Level-1-220C-UNLIM
TLC339IN	ACTIVE	PDIP	N	14	25	Pb-Free (RoHS)	CU NIPDAU	Level-NC-NC-NC
TLC339MD	ACTIVE	SOIC	D	14	50	None	CU NIPDAU	Level-1-220C-UNLIM
TLC339MDR	ACTIVE	SOIC	D	14	2500	None	CU NIPDAU	Level-1-220C-UNLIM
TLC339MN	ACTIVE	PDIP	N	14	25	None	Call TI	Level-NC-NC-NC

<sup>(1)</sup> The marketing status values are defined as follows:

**ACTIVE:** Product device recommended for new designs.

**LIFEBUY:** TI has announced that the device will be discontinued, and a lifetime-buy period is in effect.

**NRND:** Not recommended for new designs. Device is in production to support existing customers, but TI does not recommend using this part in a new design.

**PREVIEW:** Device has been announced but is not in production. Samples may or may not be available.

**OBSOLETE:** TI has discontinued the production of the device.

<sup>(2)</sup> Eco Plan - May not be currently available - please check <http://www.ti.com/productcontent> for the latest availability information and additional product content details.

**None:** Not yet available Lead (Pb-Free).

**Pb-Free (RoHS):** TI's terms "Lead-Free" or "Pb-Free" mean semiconductor products that are compatible with the current RoHS requirements for all 6 substances, including the requirement that lead not exceed 0.1% by weight in homogeneous materials. Where designed to be soldered at high temperatures, TI Pb-Free products are suitable for use in specified lead-free processes.

**Green (RoHS & no Sb/Br):** TI defines "Green" to mean "Pb-Free" and in addition, uses package materials that do not contain halogens, including bromine (Br) or antimony (Sb) above 0.1% of total product weight.

<sup>(3)</sup> MSL, Peak Temp. -- The Moisture Sensitivity Level rating according to the JEDEC industry standard classifications, and peak solder

temperature.

**Important Information and Disclaimer:**The information provided on this page represents TI's knowledge and belief as of the date that it is provided. TI bases its knowledge and belief on information provided by third parties, and makes no representation or warranty as to the accuracy of such information. Efforts are underway to better integrate information from third parties. TI has taken and continues to take reasonable steps to provide representative and accurate information but may not have conducted destructive testing or chemical analysis on incoming materials and chemicals. TI and TI suppliers consider certain information to be proprietary, and thus CAS numbers and other limited information may not be available for release.

In no event shall TI's liability arising out of such information exceed the total purchase price of the TI part(s) at issue in this document sold by TI to Customer on an annual basis.

J (R-GDIP-T\*\*)

14 LEADS SHOWN

CERAMIC DUAL IN-LINE PACKAGE



DIM \ PINS **	14	16	18	20
A	0.300 (7,62) BSC	0.300 (7,62) BSC	0.300 (7,62) BSC	0.300 (7,62) BSC
B MAX	0.785 (19,94)	.840 (21,34)	0.960 (24,38)	1.060 (26,92)
B MIN	—	—	—	—
C MAX	0.300 (7,62)	0.300 (7,62)	0.310 (7,87)	0.300 (7,62)
C MIN	0.245 (6,22)	0.245 (6,22)	0.220 (5,59)	0.245 (6,22)



4040083/F 03/03

- NOTES:
- A. All linear dimensions are in inches (millimeters).
  - B. This drawing is subject to change without notice.
  - C. This package is hermetically sealed with a ceramic lid using glass frit.
  - D. Index point is provided on cap for terminal identification only on press ceramic glass frit seal only.
  - E. Falls within MIL STD 1835 GDIP1-T14, GDIP1-T16, GDIP1-T18 and GDIP1-T20.

FK (S-CQCC-N\*\*)

LEADLESS CERAMIC CHIP CARRIER

28 TERMINAL SHOWN

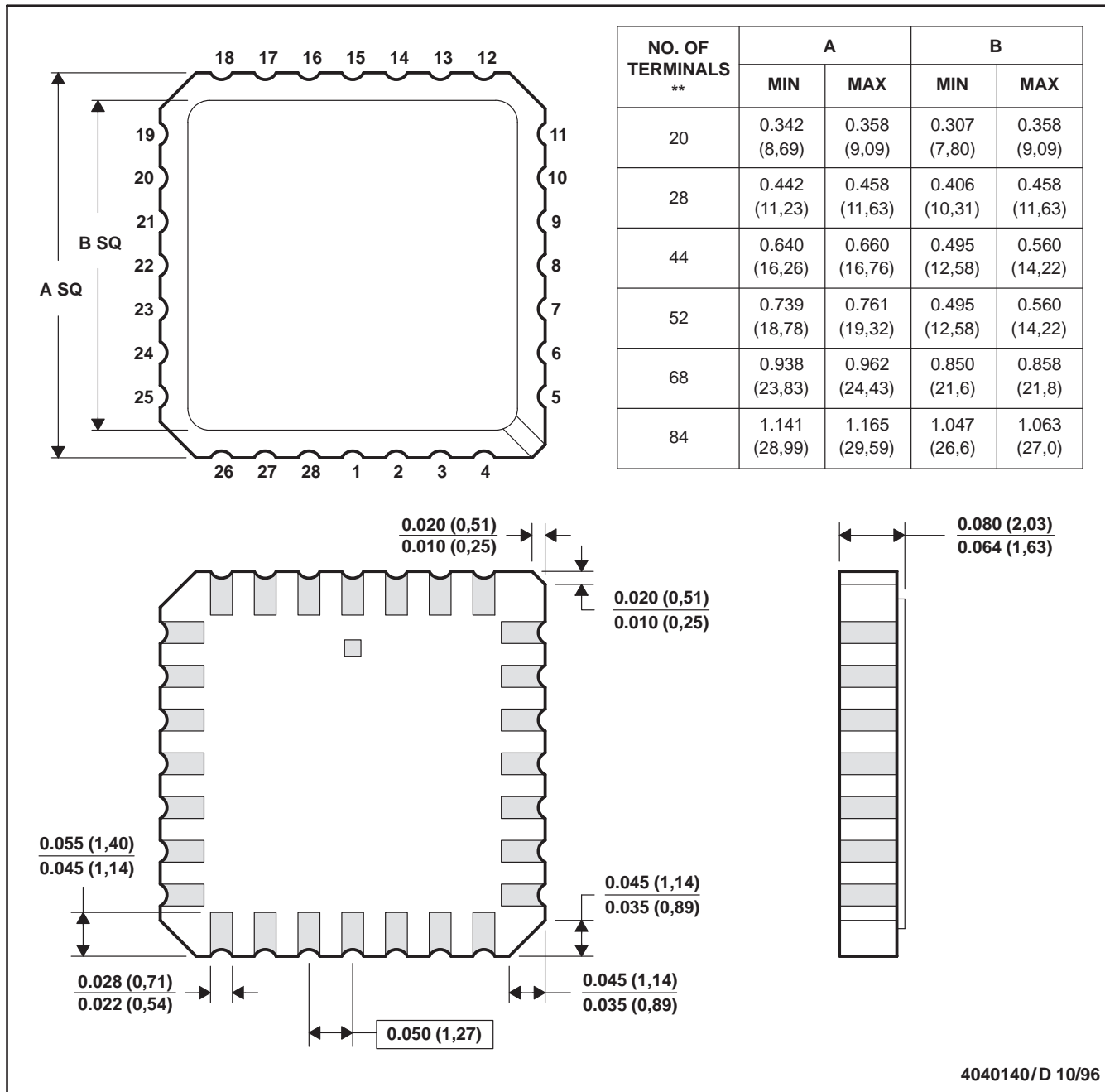

4040140/D 10/96

- NOTES:
- A. All linear dimensions are in inches (millimeters).
  - B. This drawing is subject to change without notice.
  - C. This package can be hermetically sealed with a metal lid.
  - D. The terminals are gold plated.
  - E. Falls within JEDEC MS-004

N (R-PDIP-T\*\*)

PLASTIC DUAL-IN-LINE PACKAGE

16 PINS SHOWN



- NOTES:
- A. All linear dimensions are in inches (millimeters).
  - B. This drawing is subject to change without notice.
  - Falls within JEDEC MS-001, except 18 and 20 pin minimum body length (Dim A).
  - The 20 pin end lead shoulder width is a vendor option, either half or full width.



# MECHANICAL DATA

NS (R-PDSO-G\*\*)

PLASTIC SMALL-OUTLINE PACKAGE

14-PINS SHOWN



- NOTES:
- A. All linear dimensions are in millimeters.
  - B. This drawing is subject to change without notice.
  - C. Body dimensions do not include mold flash or protrusion, not to exceed 0,15.

DB (R-PDSO-G\*\*)

PLASTIC SMALL-OUTLINE

28 PINS SHOWN



- NOTES: A. All linear dimensions are in millimeters.  
 B. This drawing is subject to change without notice.  
 C. Body dimensions do not include mold flash or protrusion not to exceed 0,15.  
 D. Falls within JEDEC MO-150

PW (R-PDSO-G\*\*)

PLASTIC SMALL-OUTLINE PACKAGE

14 PINS SHOWN



4040064/F 01/97

- NOTES: A. All linear dimensions are in millimeters.  
 B. This drawing is subject to change without notice.  
 C. Body dimensions do not include mold flash or protrusion not to exceed 0,15.  
 D. Falls within JEDEC MO-153

## IMPORTANT NOTICE

Texas Instruments Incorporated and its subsidiaries (TI) reserve the right to make corrections, modifications, enhancements, improvements, and other changes to its products and services at any time and to discontinue any product or service without notice. Customers should obtain the latest relevant information before placing orders and should verify that such information is current and complete. All products are sold subject to TI's terms and conditions of sale supplied at the time of order acknowledgment.

TI warrants performance of its hardware products to the specifications applicable at the time of sale in accordance with TI's standard warranty. Testing and other quality control techniques are used to the extent TI deems necessary to support this warranty. Except where mandated by government requirements, testing of all parameters of each product is not necessarily performed.

TI assumes no liability for applications assistance or customer product design. Customers are responsible for their products and applications using TI components. To minimize the risks associated with customer products and applications, customers should provide adequate design and operating safeguards.

TI does not warrant or represent that any license, either express or implied, is granted under any TI patent right, copyright, mask work right, or other TI intellectual property right relating to any combination, machine, or process in which TI products or services are used. Information published by TI regarding third-party products or services does not constitute a license from TI to use such products or services or a warranty or endorsement thereof. Use of such information may require a license from a third party under the patents or other intellectual property of the third party, or a license from TI under the patents or other intellectual property of TI.

Reproduction of information in TI data books or data sheets is permissible only if reproduction is without alteration and is accompanied by all associated warranties, conditions, limitations, and notices. Reproduction of this information with alteration is an unfair and deceptive business practice. TI is not responsible or liable for such altered documentation.

Resale of TI products or services with statements different from or beyond the parameters stated by TI for that product or service voids all express and any implied warranties for the associated TI product or service and is an unfair and deceptive business practice. TI is not responsible or liable for any such statements.

Following are URLs where you can obtain information on other Texas Instruments products and application solutions:

<b>Products</b>		<b>Applications</b>	
Amplifiers	<a href="http://amplifier.ti.com">amplifier.ti.com</a>	Audio	<a href="http://www.ti.com/audio">www.ti.com/audio</a>
Data Converters	<a href="http://dataconverter.ti.com">dataconverter.ti.com</a>	Automotive	<a href="http://www.ti.com/automotive">www.ti.com/automotive</a>
DSP	<a href="http://dsp.ti.com">dsp.ti.com</a>	Broadband	<a href="http://www.ti.com/broadband">www.ti.com/broadband</a>
Interface	<a href="http://interface.ti.com">interface.ti.com</a>	Digital Control	<a href="http://www.ti.com/digitalcontrol">www.ti.com/digitalcontrol</a>
Logic	<a href="http://logic.ti.com">logic.ti.com</a>	Military	<a href="http://www.ti.com/military">www.ti.com/military</a>
Power Mgmt	<a href="http://power.ti.com">power.ti.com</a>	Optical Networking	<a href="http://www.ti.com/opticalnetwork">www.ti.com/opticalnetwork</a>
Microcontrollers	<a href="http://microcontroller.ti.com">microcontroller.ti.com</a>	Security	<a href="http://www.ti.com/security">www.ti.com/security</a>
		Telephony	<a href="http://www.ti.com/telephony">www.ti.com/telephony</a>
		Video & Imaging	<a href="http://www.ti.com/video">www.ti.com/video</a>
		Wireless	<a href="http://www.ti.com/wireless">www.ti.com/wireless</a>

Mailing Address: Texas Instruments  
Post Office Box 655303 Dallas, Texas 75265