

The TL7705BM is obsolete and no longer is supplied.

- Power-On Reset Generator
- Automatic Reset Generation After Voltage Drop
- $\overline{\text{RESET}}$ Output Defined From $V_{CC} \geq 1 \text{ V}$
- Precision Voltage Sensor
- Temperature-Compensated Voltage Reference
- True and Complement Reset Outputs
- Externally Adjustable Pulse Duration

TL77xxBC ... D OR P PACKAGE
TL7705BM ... JG PACKAGE
TL7705BQ ... D PACKAGE
(TOP VIEW)

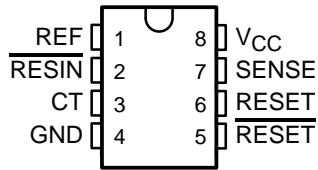

TL7705BM ... U PACKAGE
(TOP VIEW)

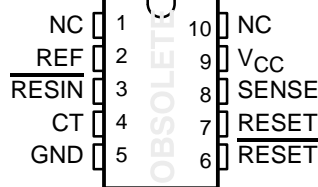

NC – No internal connection

TL7705BM ... FK PACKAGE
(TOP VIEW)

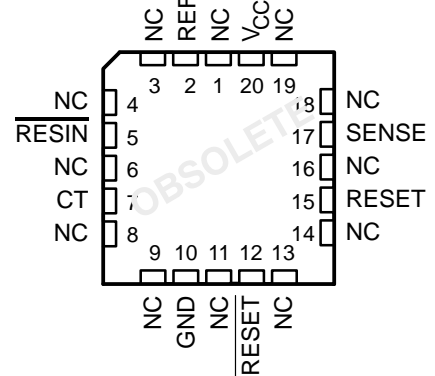

NC – No internal connection

description/ordering information

The TL7702B, TL7705B, and TL7733B are integrated-circuit supply-voltage supervisors designed for use as reset controllers in microcomputer and microprocessor systems. The supply-voltage supervisor monitors the supply for undervoltage conditions at the SENSE input. During power up, the $\overline{\text{RESET}}$ output becomes active (low) when V_{CC} attains a value approaching 1 V. As V_{CC} approaches 3 V (assuming that SENSE is above V_{T+}), the delay-timer function activates a time delay, after which outputs $\overline{\text{RESET}}$ and RESET go inactive (high and low, respectively). When an undervoltage condition occurs during normal operation, outputs $\overline{\text{RESET}}$ and RESET go active. To ensure that a complete reset occurs, the reset outputs remain active for a time delay after the voltage at the SENSE input exceeds the positive-going threshold value. The time delay is determined by the value of the external capacitor C_T . $t_d \approx 2.6 \times 10^4 \times C_T$, where C_T is in farads (F) and t_d is in seconds (s).

An external capacitor (typically 0.1 μF) must be connected to REF to reduce the influence of fast transients in the supply voltage.

The TL7702BC, TL7705BC, and TL7733BC are characterized for operation from 0°C to 70°C. The TL7702BI, TL7705BI, and TL7733BI are characterized for operation from –40°C to 85°C. The TL7705BQ is characterized for operation from –40°C to 125°C. The TL7705BM is characterized for operation from –55°C to 125°C.



Please be aware that an important notice concerning availability, standard warranty, and use in critical applications of Texas Instruments semiconductor products and disclaimers thereto appears at the end of this data sheet.

PRODUCTION DATA information is current as of publication date. Products conform to specifications per the terms of Texas Instruments standard warranty. Production processing does not necessarily include testing of all parameters.

 **TEXAS
INSTRUMENTS**

POST OFFICE BOX 655303 • DALLAS, TEXAS 75265

Copyright © 2003, Texas Instruments Incorporated
On products compliant to MIL-PRF-38535, all parameters are tested unless otherwise noted. On all other products, production processing does not necessarily include testing of all parameters.

TL7702B, TL7705B, TL7733B SUPPLY-VOLTAGE SUPERVISORS

The TL7705BM is obsolete
and no longer is supplied.

SLVS037M – SEPTEMBER 1989 – REVISED MAY 2003

description/ordering information (continued)

ORDERING INFORMATION

TA	PACKAGE†		ORDERABLE PART NUMBER	TOP-SIDE MARKING	
0°C to 70°C	PDIP (P)	Tube of 50	TL7702BCP	TL7702BCP	
	SOIC (D)	Tube of 75	TL7702BCD	7702BC	
		Reel of 2500	TL7702BCDR		
	PDIP (P)	Tube of 50	TL7705BCP	TL7705BCP	
	SOIC (D)	Tube of 75	TL7705BCD	7705BC	
		Reel of 2500	TL7705BCDR		
	PDIP (P)	Tube of 50	TL7733BCP	TL7733BCP	
	SOIC (D)	Tube of 75	TL7733BCD	7733BC	
		Reel of 2500	TL7733BCDR		
	-40°C to 85°C	PDIP (P)	Tube of 50	TL7702BIP	TL7702BIP
		SOIC (D)	Tube of 75	TL7702BID	7702BI
			Reel of 2500	TL7702BIDR	
PDIP (P)		Tube of 50	TL7705BIP	TL7705BIP	
SOIC (D)		Tube of 75	TL7705BID	7705BI	
		Reel of 2500	TL7705BIDR		
PDIP (P)		Tube of 50	TL7733BIP	TL7705BIP	
SOIC (D)		Tube of 75	TL7733BID	7733BI	
		Reel of 2500	TL7733BIDR		
-40°C to 125°C		SOIC (D)	Tube of 75	TL7705BQD	TL7705BQD

† Package drawings, standard packing quantities, thermal data, symbolization, and PCB design guidelines are available at www.ti.com/sc/package.



The TL7705BM is obsolete
and no longer is supplied.

functional block diagram

The functional block diagram is shown for illustrative purposes only; the actual circuit includes a trimming network to adjust the reference voltage and sense-comparator trip point.

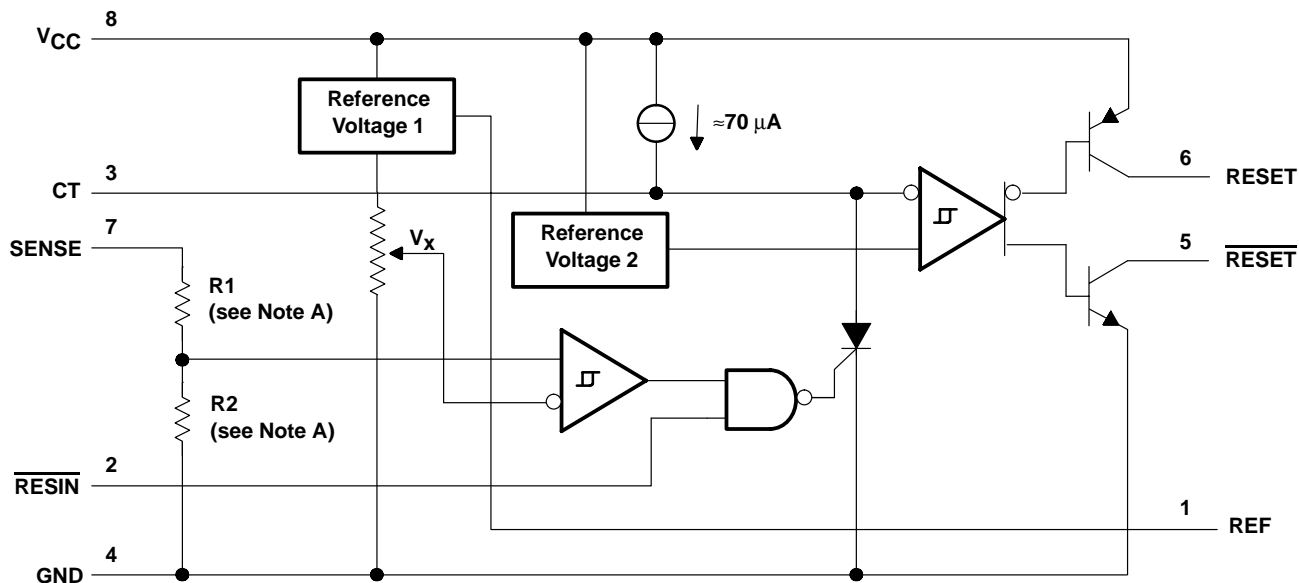

Pin numbers shown are for the D, JG, and P packages.

NOTE A: TL7702B: R1 = 0 Ω, R2 = open, $V_x = V_{REF1}$
 TL7705B: R1 = 23 kΩ, R2 = 10 kΩ, nominal, $V_x \approx 1.43$ V
 TL7733B: R1 = 11.3 kΩ, R2 = 10 kΩ, nominal, $V_x \approx 1.43$ V

typical timing diagram

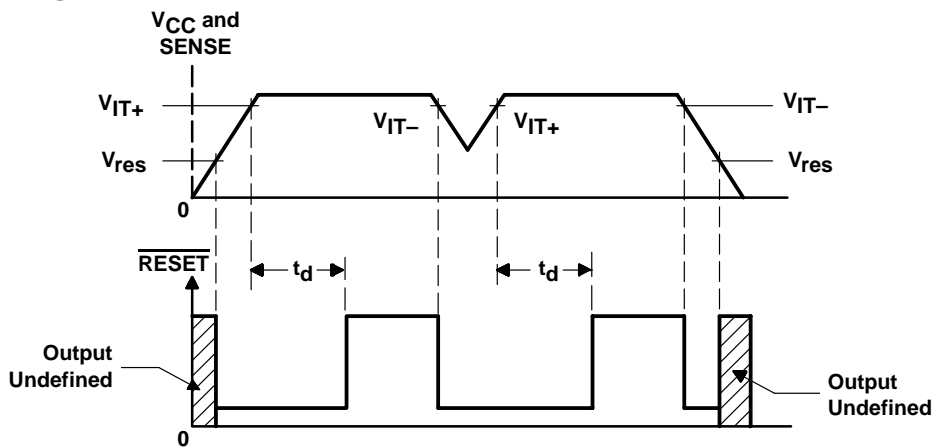

TL7702B, TL7705B, TL7733B SUPPLY-VOLTAGE SUPERVISORS

The TL7705BM is obsolete
and no longer is supplied.

SLVS037M – SEPTEMBER 1989 – REVISED MAY 2003

absolute maximum ratings over operating free-air temperature range (unless otherwise noted)†

Supply voltage, V_{CC} (see Note 1)	20 V
Input voltage range, V_I : \overline{RESIN}	-0.3 V to 20 V
SENSE	-0.3 V to 20 V
High-level output current, I_{OH} (RESET)	-30 mA
Low-level output current, I_{OL} (\overline{RESET})	30 mA
Package thermal impedance, θ_{JA} (see Notes 2 and 3): D package	97°C/W
P package	85°C/W
Operating virtual junction temperature, T_J	150°C
Case temperature for 60 seconds, T_C : FK package	260°C
Lead temperature 1,6 mm (1/16 inch) from case for 60 seconds: JG or U packages	300°C
Lead temperature 1,6 mm (1/16 inch) from case for 10 seconds: D or P packages	260°C
Storage temperature range, T_{stg}	-65°C to 150°C

† Stresses beyond those listed under “absolute maximum ratings” may cause permanent damage to the device. These are stress ratings only, and functional operation of the device at these or any other conditions beyond those indicated under “recommended operating conditions” is not implied. Exposure to absolute-maximum-rated conditions for extended periods may affect device reliability.

- NOTES:
- All voltage values are with respect to the network ground terminal.
 - Maximum power dissipation is a function of $T_J(\max)$, θ_{JA} , and T_A . The maximum allowable power dissipation at any allowable ambient temperature is $P_D = (T_J(\max) - T_A)/\theta_{JA}$. Operating at the absolute maximum T_J of 150°C can affect reliability.
 - The package thermal impedance is calculated in accordance with JESD 51-7.

recommended operating conditions

		MIN	MAX	UNIT	
V_{CC}	Supply voltage	3.6	18	V	
V_{IH}	High-level input voltage	\overline{RESIN}	2	18	V
V_{IL}	Low-level input voltage	\overline{RESIN}	0	0.8	V
V_I	Input voltage	SENSE	0	18	V
I_{OH}	High-level output current	RESET	-20	mA	
I_{OL}	Low-level output current	\overline{RESET}	20	mA	
T_A	Operating free-air temperature range	TL77xxBC	0	70	°C
		TL77xxBI	-40	85	
		TL7705BQ	-40	125	
		TL7705BM	-55	125	



The TL7705BM is obsolete
and no longer is supplied.

SLVS037M – SEPTEMBER 1989 – REVISED MAY 2003

electrical characteristics over recommended operating conditions (unless otherwise noted)

PARAMETER		TEST CONDITIONS†	TL77xxBC TL77xxBI TL7705BQ			UNIT	
			MIN	TYP	MAX		
V _{OH}	High-level output voltage, RESET	I _{OH} = -16 mA	V _{CC} -1.5			V	
V _{OL}	Low-level output voltage, RESET	I _{OL} = 16 mA	0.4			V	
V _{ref}	Reference voltage, REF	I _{ref} = -500 μA, T _A = 25°C	2.48	2.53	2.58	V	
V _{IT-}	Negative-going input threshold voltage at SENSE input	TL7702B	T _A = 25°C	2.505	2.53	2.555	V
		TL7705B		4.5	4.55	4.6	
		TL7733B		3.03	3.08	3.13	
		TL7702B	T _A = full range‡	2.48	2.53	2.58	
		TL7705B		4.45	4.55	4.65	
		TL7733B		3	3.08	3.16	
V _{hys}	Hysteresis, SENSE (V _{IT+} - V _{IT-})	TL7702B	10			mV	
		TL7705B	30				
		TL7733B	10				
V _{res} §	Power-up reset voltage	I _{OL} at RESET = 2 mA, T _A = 25°C	1			V	
I _I	Input current	RESIN	V _I = 0.4 V to V _{CC}			-10	μA
		SENSE TL7702B	V _I = V _{ref} to 18 V			-0.1 -2	
I _{OH}	High-level output current, RESET	V _O = 18 V, See Figure 1	50			μA	
I _{OL}	Low-level output current, RESET	V _O = 0 V, See Figure 1	-50			μA	
I _{CC}	Supply current	V _{SENSE} = 15 V, RESIN ≥ 2 V	1.8		3	mA	
		V _{CC} = 18 V, T _A = full range‡	3.5				

† All electrical characteristics are measured with 0.1-μF capacitors connected at REF, CT, and V_{CC} to GND.

‡ Full range is 0°C to 70°C for the C-suffix devices, -40°C to 85°C for the I-suffix devices, and -40°C to 125°C for the Q-suffix device.

§ This is the lowest voltage at which RESET becomes active.

switching characteristics, V_{CC} = 5 V, C_T open, T_A = 25°C

PARAMETER	FROM (INPUT)	TO (OUTPUT)	TEST CONDITIONS	TL77xxBC TL77xxBI TL7705BQ			UNIT
				MIN	TYP	MAX	
t _{PLH}	RESIN	RESET	See Figures 1, 2, and 3	270	500		ns
t _{PHL}	RESIN	RESET	See Figures 1, 2, and 3	270	500		ns
t _w	RESIN		See Figure 2	150			ns
	SENSE			100			
t _r		RESET	See Figures 1 and 3	75			ns
t _f				150 200			
t _r		RESET	See Figures 1 and 3	75 150			ns
t _f				50			

TL7702B, TL7705B, TL7733B SUPPLY-VOLTAGE SUPERVISORS

The TL7705BM is obsolete
and no longer is supplied.

SLVS037M – SEPTEMBER 1989 – REVISED MAY 2003

electrical characteristics over recommended operating conditions (unless otherwise noted)

PARAMETER		TEST CONDITION [†]	TL7705BM			UNIT	
			MIN	TYP	MAX		
V _{OH}	High-level output voltage, RESET	I _{OH} = -16 mA	V _{CC} -1.5			V	
V _{OL}	Low-level output voltage, RESET	I _{OL} = 16 mA	0.4			V	
V _{ref}	Reference voltage, REF	I _{ref} = -500 μA, T _A = 25°C	2.48	2.53	2.58	V	
V _{IT-}	Negative-going input threshold voltage at SENSE input	T _A = 25°C	TL7702B	2.505	2.53	2.555	V
			TL7705B	4.5	4.55	4.6	
		T _A = -55°C to 125°C	TL7702B	2.48	2.53	2.58	
			TL7705B	4.45	4.55	4.65	
V _{hys}	Hysteresis, SENSE (V _{IT+} - V _{IT-})	V _{CC} = 3.6 V to 18 V, T _A = 25°C	10			mV	
			30				
V _{res} [‡]	Power-up reset voltage	I _{OL} at RESET = 2 mA, T _A = 25°C	1			V	
I _I	RESIN	V _I = 0.4 V to V _{CC}	-10			μA	
	SENSE TL7702B	V _I = V _{ref} to V _{CC} - 1.5 V	-0.1 -2				
I _{OH}	High-level output current, RESET	V _O = 18 V	50			μA	
I _{OL}	Low-level output current, RESET	V _O = 0	-50			μA	
I _{CC}	Supply current	V _{SENSE} = 15 V, RESIN ≥ 2 V	1.8 3			mA	
		V _{CC} = 18 V, T _A = -55°C to 125°C	4				

[†] All electrical characteristics are measured with 0.1-μF capacitors connected at REF, CT, and V_{CC} to GND.

[‡] This is the lowest value at which RESET becomes active.

switching characteristics, V_{CC} = 5 V, C_T open, T_A = 25°C

PARAMETER	FROM (INPUT)	TO (OUTPUT)	TEST CONDITIONS	TL7705BM			UNIT
				MIN	TYP	MAX	
t _{PLH}	RESIN	RESET	See Figures 1, 2, and 3	270	500*		ns
t _{PHL}	RESIN	RESET	See Figures 1, 2, and 3	270	500*		ns
t _w	RESIN		See Figure 2	150			ns
	SENSE			100			
t _r		RESET	See Figures 1 and 3	75*			ns
t _f				150 200*			
t _r		RESET	See Figures 1 and 3	75 150*			ns
t _f				50*			

* On products compliant to MIL-PRF-38535, these parameters are not production tested.



The TL7705BM is obsolete
and no longer is supplied.

PARAMETER MEASUREMENT INFORMATION

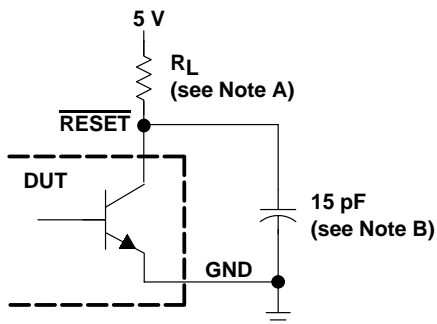

RESET OUTPUT CONFIGURATION

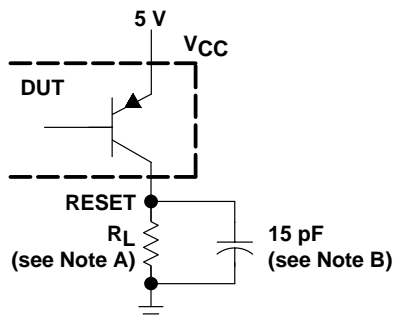

RESET OUTPUT CONFIGURATION

NOTES: A. For I_{OL} and I_{OH} , $R_L = 10\text{ k}\Omega$. For all switching characteristics, $R_L = 511\ \Omega$.
B. This figure includes jig and probe capacitance.

Figure 1. RESET and RESET Output Configurations



WAVEFORMS

Figure 2. Input Pulse Definition

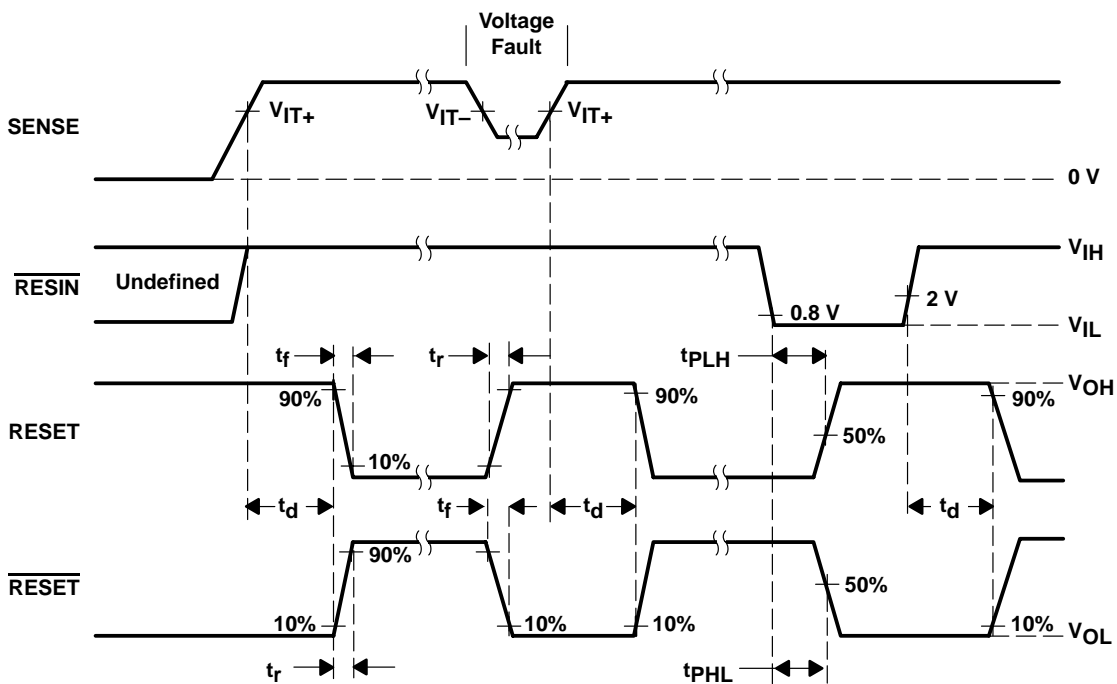

Figure 3. Voltage Waveforms

TYPICAL CHARACTERISTICS†

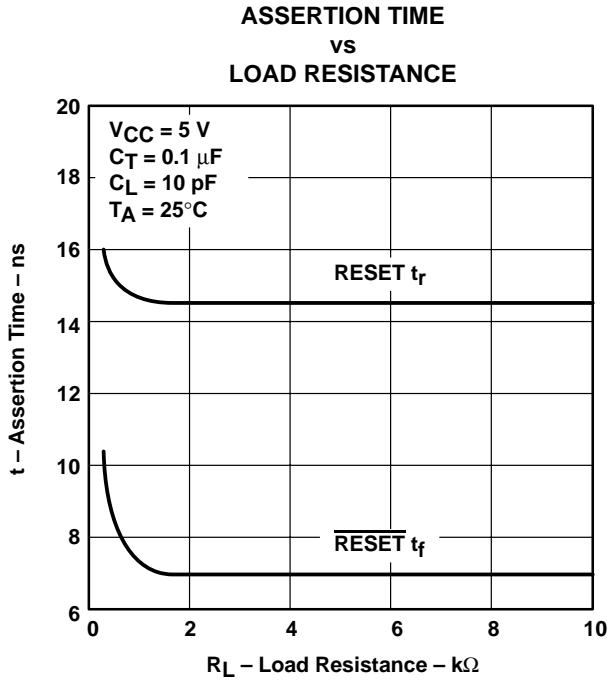

Figure 4

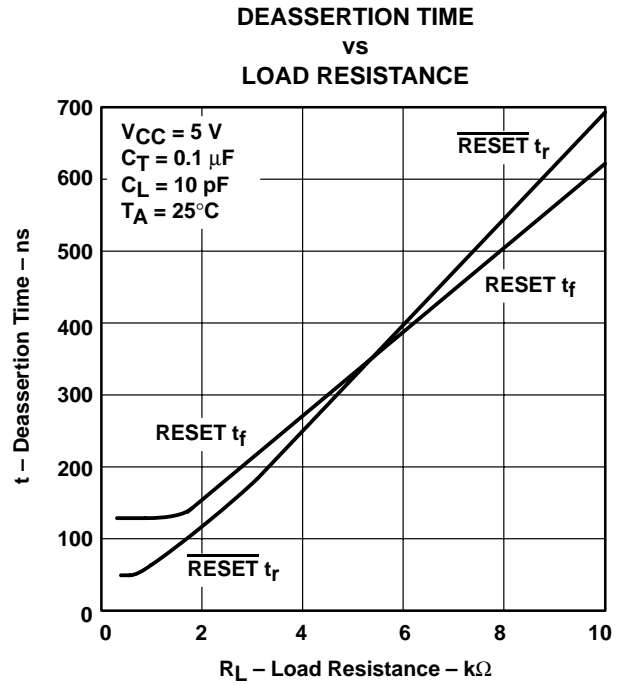

Figure 5

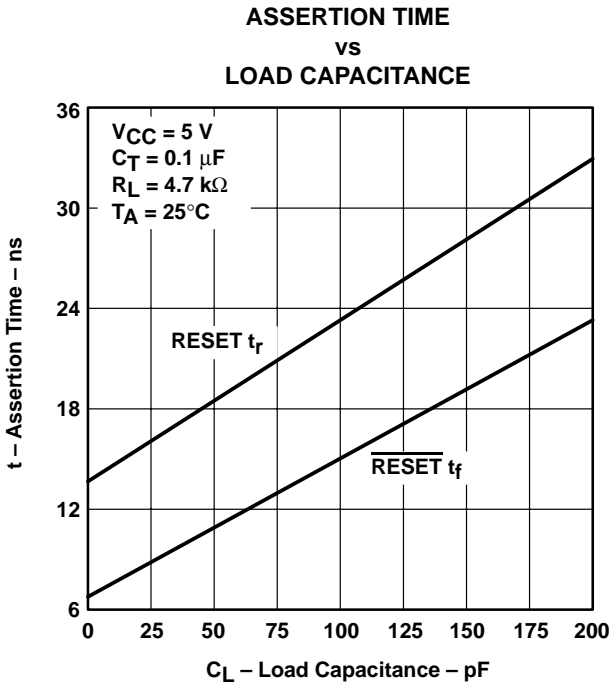

Figure 6

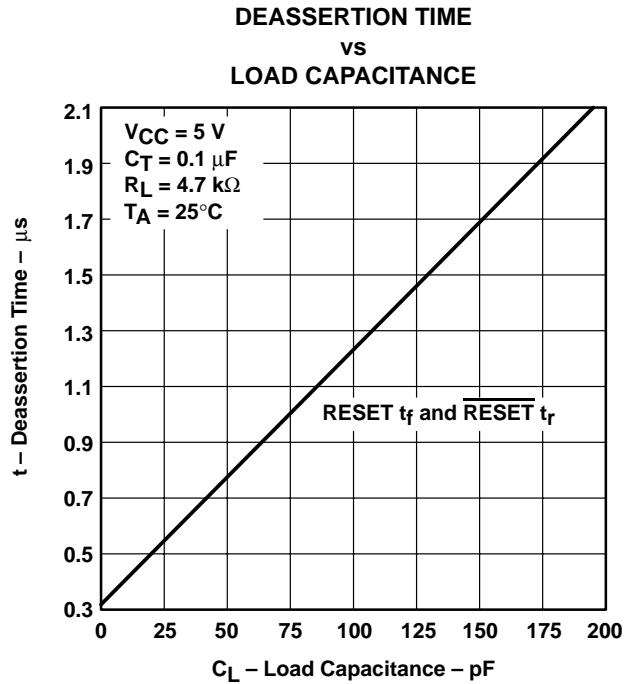

Figure 7

† For proper operation, both $\overline{\text{RESET}}$ and $\overline{\text{RESET}}$ should be terminated with resistors of similar value. Failure to do so may cause unwanted plateauing in either output waveform during switching.

APPLICATION INFORMATION

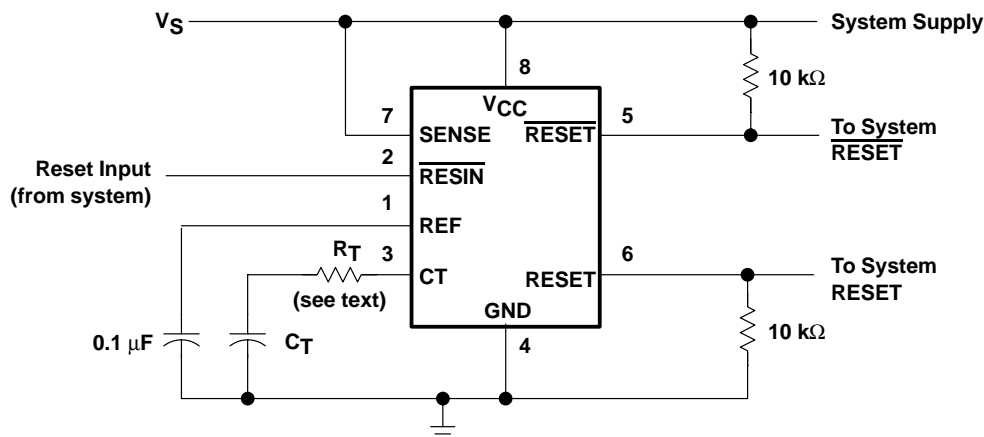

Figure 8. System Reset Controller With Undervoltage Sensing

When the TL770xB SENSE terminal is used to monitor V_{CC} , a current-limiting resistor in series with C_T is recommended. During normal operation, the timing capacitor is charged by the onboard current source to approximately V_{CC} or an internal voltage clamp (≈ 7.1 -V Zener), whichever is less. When the circuit then is subjected to an undervoltage condition during which V_{CC} is rapidly slewed down, the voltage on CT exceeds that on V_{CC} . This forward biases a secondary path internally, which falsely activates the outputs. A fault is indicated when V_{CC} drops below $V_{(CT)}$, not when V_{SENSE} falls below V_{T-} .

Texas Instruments performs a 100% electrical screen to verify that the outputs do not switch with 1 mA forced into the CT terminal. Adding the external resistor, R_T , prevents false triggering. Its value is calculated as follows:

$$\frac{V_{(CT)} - V_{T-}}{R_T}$$

Where:

- $V_{(CT)}$ = V_{CC} or 7.1 V, whichever is less
- V_{T-} = 4.55 V (nom)
- R_T = value of series resistor required

For $V_{CC} = 5$ V:

$$\frac{5 - 4.55}{R_T} < 1 \text{ mA}$$

Therefore,

$$R_T > 450 \ \Omega$$

Using a 20%-tolerance resistor, R_T should be greater than 560 Ω .

Adding this series resistor changes the duration of the reset pulse by no more than 10%. R_T extends the discharge of C_T , but also skews the $V_{(CT)}$ threshold. These effects tend to cancel one another. The precise percentage change can be derived theoretically, but the equation is complicated by this interaction and is dependent upon the duration of the supply-voltage fault condition.

Both outputs of the TL770xB should be terminated with similar value resistors, even when only one is being used. This prevents unwanted plateauing in either output waveform during switching, which may be interpreted as an undefined state or delay system reset.

PACKAGING INFORMATION

Orderable Device	Status ⁽¹⁾	Package Type	Package Drawing	Pins	Package Qty	Eco Plan ⁽²⁾	Lead/Ball Finish	MSL Peak Temp ⁽³⁾
5962-88685042A	OBSOLETE	LCCC	FK	20		None	Call TI	Call TI
5962-8868504HA	OBSOLETE	CFP	U	10		None	Call TI	Call TI
5962-88685052A	OBSOLETE	LCCC	FK	20		None	Call TI	Call TI
5962-8868505HA	OBSOLETE	CFP	U	10		None	Call TI	Call TI
5962-8868505PA	OBSOLETE	CDIP	JG	8		None	Call TI	Call TI
TL7702BCD	ACTIVE	SOIC	D	8	75	Pb-Free (RoHS)	CU NIPDAU	Level-2-250C-1 YEAR
TL7702BCDR	ACTIVE	SOIC	D	8	2500	Pb-Free (RoHS)	CU NIPDAU	Level-2-250C-1 YEAR
TL7702BCP	ACTIVE	PDIP	P	8	50	Pb-Free (RoHS)	CU NIPDAU	Level-NC-NC-NC
TL7702BID	ACTIVE	SOIC	D	8	75	Pb-Free (RoHS)	CU NIPDAU	Level-2-250C-1 YEAR
TL7702BIDR	ACTIVE	SOIC	D	8	2500	Pb-Free (RoHS)	CU NIPDAU	Level-2-250C-1 YEAR
TL7702BIP	ACTIVE	PDIP	P	8	50	Pb-Free (RoHS)	CU NIPDAU	Level-NC-NC-NC
TL7702BMFKB	OBSOLETE	LCCC	FK	20		None	Call TI	Call TI
TL7702BMJG	OBSOLETE	CDIP	JG	8		None	Call TI	Call TI
TL7702BMJGB	OBSOLETE	CDIP	JG	8		None	Call TI	Call TI
TL7702BMUB	OBSOLETE	CFP	U	10		None	Call TI	Call TI
TL7702BQD	OBSOLETE	SOIC	D	8		None	Call TI	Call TI
TL7702BQDR	OBSOLETE	SOIC	D	8		None	Call TI	Call TI
TL7702BQP	OBSOLETE	PDIP	P	8		None	Call TI	Call TI
TL7705BCD	ACTIVE	SOIC	D	8	75	Pb-Free (RoHS)	CU NIPDAU	Level-2-250C-1 YEAR
TL7705BCDR	ACTIVE	SOIC	D	8	2500	Pb-Free (RoHS)	CU NIPDAU	Level-2-250C-1 YEAR
TL7705BCP	ACTIVE	PDIP	P	8	50	Pb-Free (RoHS)	CU NIPDAU	Level-NC-NC-NC
TL7705BID	ACTIVE	SOIC	D	8	75	Pb-Free (RoHS)	CU NIPDAU	Level-2-250C-1 YEAR
TL7705BIDR	ACTIVE	SOIC	D	8	2500	Pb-Free (RoHS)	CU NIPDAU	Level-2-250C-1 YEAR
TL7705BIP	ACTIVE	PDIP	P	8	50	Pb-Free (RoHS)	CU NIPDAU	Level-NC-NC-NC
TL7705BMFKB	OBSOLETE	LCCC	FK	20		None	Call TI	Call TI
TL7705BMJG	OBSOLETE	CDIP	JG	8		None	Call TI	Call TI
TL7705BMJGB	OBSOLETE	CDIP	JG	8		None	Call TI	Call TI
TL7705BMUB	OBSOLETE	CFP	U	10		None	Call TI	Call TI
TL7705BQD	ACTIVE	SOIC	D	8	75	None	CU NIPDAU	Level-1-220C-UNLIM
TL7705BQDR	ACTIVE	SOIC	D	8	2500	None	CU NIPDAU	Level-1-220C-UNLIM
TL7705BQP	OBSOLETE	PDIP	P	8		None	Call TI	Call TI
TL7733BCD	ACTIVE	SOIC	D	8	75	Pb-Free (RoHS)	CU NIPDAU	Level-2-250C-1 YEAR
TL7733BCDR	ACTIVE	SOIC	D	8	2500	Pb-Free	CU NIPDAU	Level-2-250C-1 YEAR

Orderable Device	Status ⁽¹⁾	Package Type	Package Drawing	Pins	Package Qty	Eco Plan ⁽²⁾	Lead/Ball Finish	MSL Peak Temp ⁽³⁾
						(RoHS)		
TL7733BCP	ACTIVE	PDIP	P	8	50	Pb-Free (RoHS)	CU NIPDAU	Level-NC-NC-NC
TL7733BID	ACTIVE	SOIC	D	8	75	Pb-Free (RoHS)	CU NIPDAU	Level-2-250C-1 YEAR
TL7733BIDR	ACTIVE	SOIC	D	8	2500	Pb-Free (RoHS)	CU NIPDAU	Level-2-250C-1 YEAR
TL7733BIP	ACTIVE	PDIP	P	8	50	Pb-Free (RoHS)	CU NIPDAU	Level-NC-NC-NC

⁽¹⁾ The marketing status values are defined as follows:

ACTIVE: Product device recommended for new designs.

LIFEBUY: TI has announced that the device will be discontinued, and a lifetime-buy period is in effect.

NRND: Not recommended for new designs. Device is in production to support existing customers, but TI does not recommend using this part in a new design.

PREVIEW: Device has been announced but is not in production. Samples may or may not be available.

OBSOLETE: TI has discontinued the production of the device.

⁽²⁾ Eco Plan - May not be currently available - please check <http://www.ti.com/productcontent> for the latest availability information and additional product content details.

None: Not yet available Lead (Pb-Free).

Pb-Free (RoHS): TI's terms "Lead-Free" or "Pb-Free" mean semiconductor products that are compatible with the current RoHS requirements for all 6 substances, including the requirement that lead not exceed 0.1% by weight in homogeneous materials. Where designed to be soldered at high temperatures, TI Pb-Free products are suitable for use in specified lead-free processes.

Green (RoHS & no Sb/Br): TI defines "Green" to mean "Pb-Free" and in addition, uses package materials that do not contain halogens, including bromine (Br) or antimony (Sb) above 0.1% of total product weight.

⁽³⁾ MSL, Peak Temp. -- The Moisture Sensitivity Level rating according to the JEDEC industry standard classifications, and peak solder temperature.

Important Information and Disclaimer: The information provided on this page represents TI's knowledge and belief as of the date that it is provided. TI bases its knowledge and belief on information provided by third parties, and makes no representation or warranty as to the accuracy of such information. Efforts are underway to better integrate information from third parties. TI has taken and continues to take reasonable steps to provide representative and accurate information but may not have conducted destructive testing or chemical analysis on incoming materials and chemicals. TI and TI suppliers consider certain information to be proprietary, and thus CAS numbers and other limited information may not be available for release.

In no event shall TI's liability arising out of such information exceed the total purchase price of the TI part(s) at issue in this document sold by TI to Customer on an annual basis.

JG (R-GDIP-T8)

CERAMIC DUAL-IN-LINE

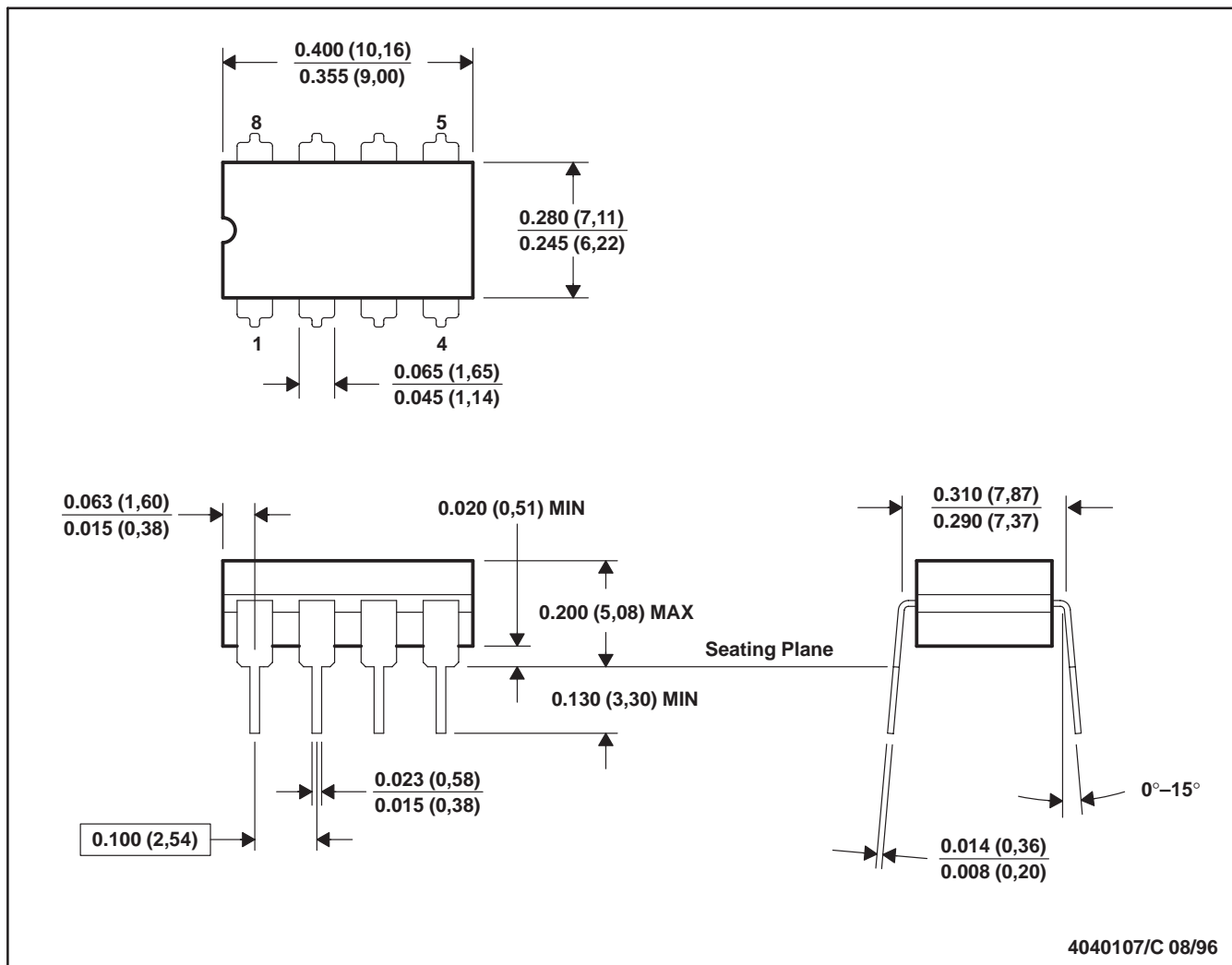

- NOTES: A. All linear dimensions are in inches (millimeters).
 B. This drawing is subject to change without notice.
 C. This package can be hermetically sealed with a ceramic lid using glass frit.
 D. Index point is provided on cap for terminal identification.
 E. Falls within MIL STD 1835 GDIP1-T8

U (S-GDFP-F10)

CERAMIC DUAL FLATPACK

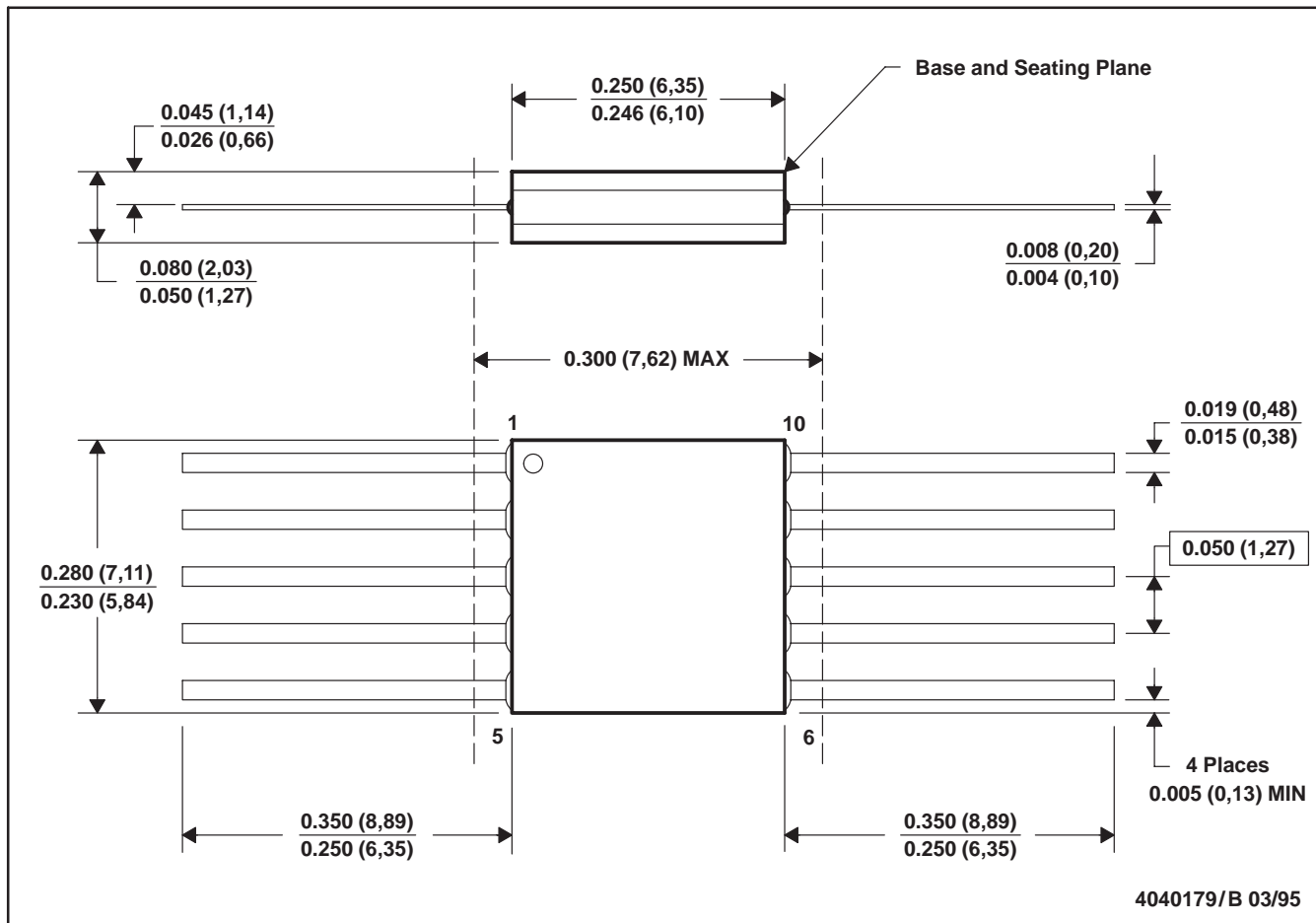

- NOTES: A. All linear dimensions are in inches (millimeters).
 B. This drawing is subject to change without notice.
 C. This package can be hermetically sealed with a ceramic lid using glass frit.
 D. Index point is provided on cap for terminal identification only.
 E. Falls within MIL STD 1835 GDFP1-F10 and JEDEC MO-092AA

FK (S-CQCC-N**)

LEADLESS CERAMIC CHIP CARRIER

28 TERMINAL SHOWN



4040140/D 10/96

- NOTES:
- A. All linear dimensions are in inches (millimeters).
 - B. This drawing is subject to change without notice.
 - C. This package can be hermetically sealed with a metal lid.
 - D. The terminals are gold plated.
 - E. Falls within JEDEC MS-004

P (R-PDIP-T8)

PLASTIC DUAL-IN-LINE

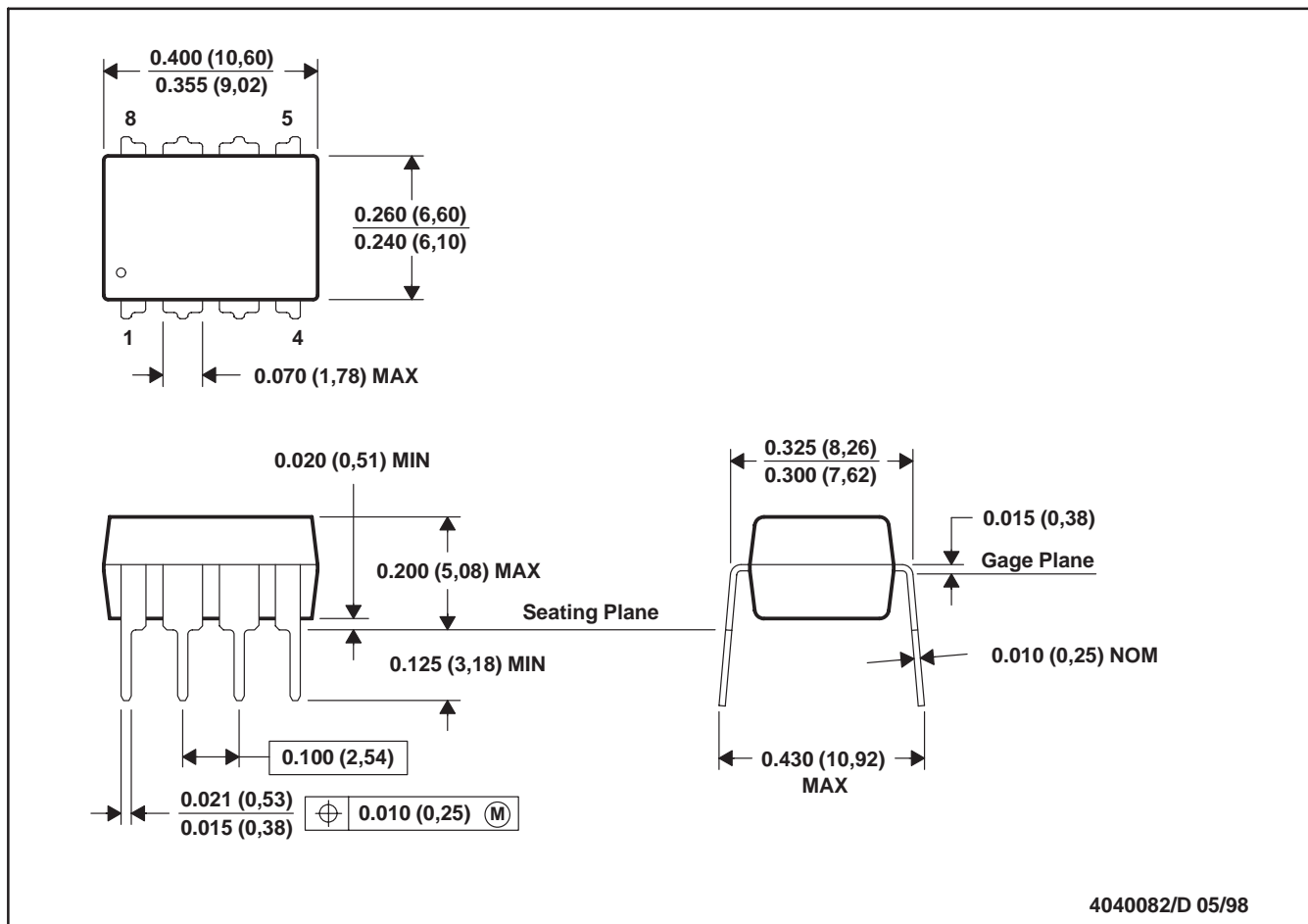

- NOTES: A. All linear dimensions are in inches (millimeters).
 B. This drawing is subject to change without notice.
 C. Falls within JEDEC MS-001

For the latest package information, go to http://www.ti.com/sc/docs/package/pkg_info.htm

D (R-PDSO-G8)

PLASTIC SMALL-OUTLINE PACKAGE

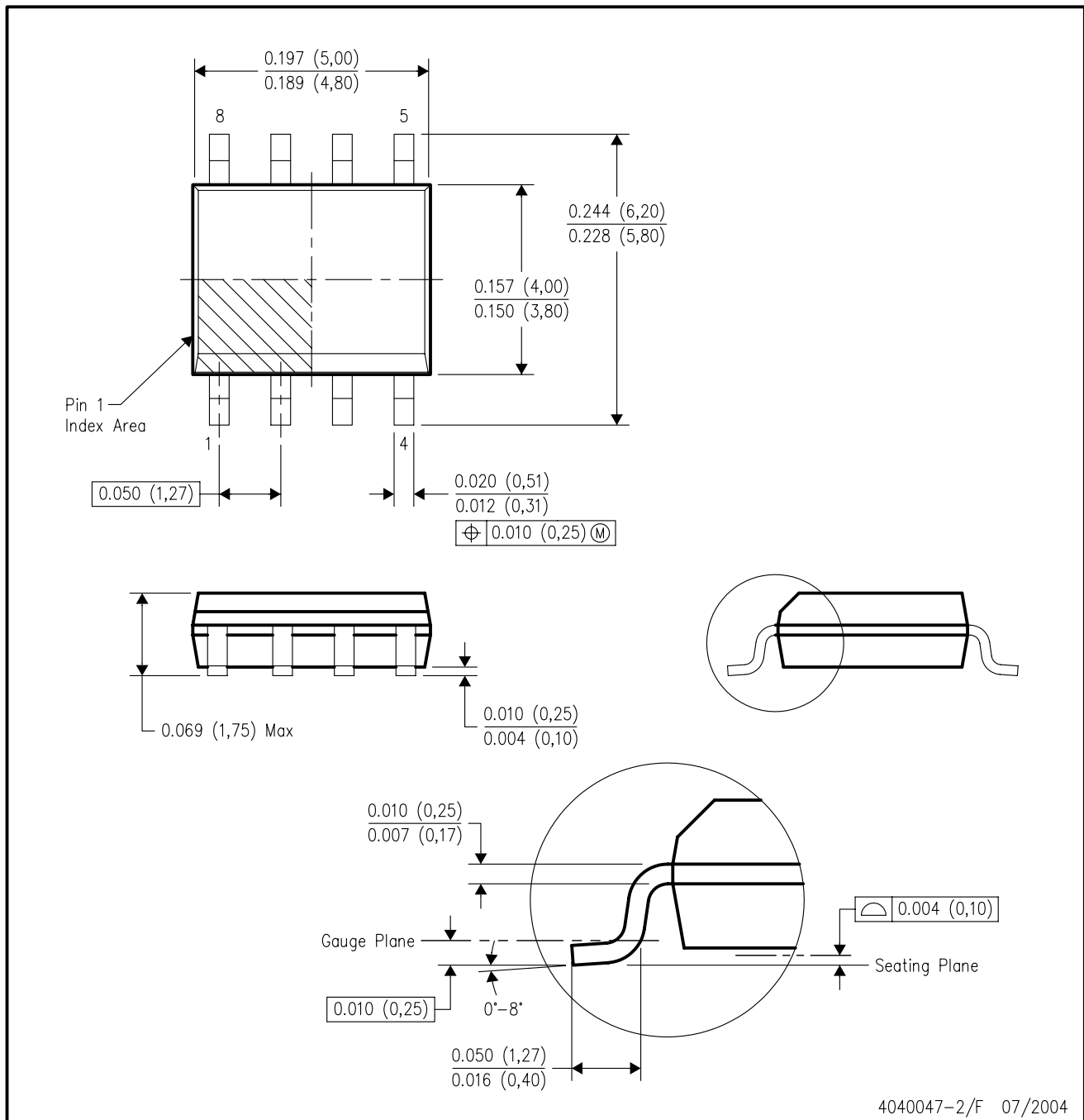

- NOTES:
- A. All linear dimensions are in inches (millimeters).
 - B. This drawing is subject to change without notice.
 - C. Body dimensions do not include mold flash or protrusion not to exceed 0.006 (0,15).
 - D. Falls within JEDEC MS-012 variation AA.

IMPORTANT NOTICE

Texas Instruments Incorporated and its subsidiaries (TI) reserve the right to make corrections, modifications, enhancements, improvements, and other changes to its products and services at any time and to discontinue any product or service without notice. Customers should obtain the latest relevant information before placing orders and should verify that such information is current and complete. All products are sold subject to TI's terms and conditions of sale supplied at the time of order acknowledgment.

TI warrants performance of its hardware products to the specifications applicable at the time of sale in accordance with TI's standard warranty. Testing and other quality control techniques are used to the extent TI deems necessary to support this warranty. Except where mandated by government requirements, testing of all parameters of each product is not necessarily performed.

TI assumes no liability for applications assistance or customer product design. Customers are responsible for their products and applications using TI components. To minimize the risks associated with customer products and applications, customers should provide adequate design and operating safeguards.

TI does not warrant or represent that any license, either express or implied, is granted under any TI patent right, copyright, mask work right, or other TI intellectual property right relating to any combination, machine, or process in which TI products or services are used. Information published by TI regarding third-party products or services does not constitute a license from TI to use such products or services or a warranty or endorsement thereof. Use of such information may require a license from a third party under the patents or other intellectual property of the third party, or a license from TI under the patents or other intellectual property of TI.

Reproduction of information in TI data books or data sheets is permissible only if reproduction is without alteration and is accompanied by all associated warranties, conditions, limitations, and notices. Reproduction of this information with alteration is an unfair and deceptive business practice. TI is not responsible or liable for such altered documentation.

Resale of TI products or services with statements different from or beyond the parameters stated by TI for that product or service voids all express and any implied warranties for the associated TI product or service and is an unfair and deceptive business practice. TI is not responsible or liable for any such statements.

Following are URLs where you can obtain information on other Texas Instruments products and application solutions:

Products		Applications	
Amplifiers	amplifier.ti.com	Audio	www.ti.com/audio
Data Converters	dataconverter.ti.com	Automotive	www.ti.com/automotive
DSP	dsp.ti.com	Broadband	www.ti.com/broadband
Interface	interface.ti.com	Digital Control	www.ti.com/digitalcontrol
Logic	logic.ti.com	Military	www.ti.com/military
Power Mgmt	power.ti.com	Optical Networking	www.ti.com/opticalnetwork
Microcontrollers	microcontroller.ti.com	Security	www.ti.com/security
		Telephony	www.ti.com/telephony
		Video & Imaging	www.ti.com/video
		Wireless	www.ti.com/wireless

Mailing Address: Texas Instruments
Post Office Box 655303 Dallas, Texas 75265