

SN55113, SN75113 DUAL DIFFERENTIAL LINE DRIVERS

SLLS070C – SEPTEMBER 1973 – REVISED MARCH 1997

- Choice of Open-Collector, Open-Emitter, or 3-State Outputs
- High-Impedance Output State for Party-Line Applications
- Single-Ended or Differential AND/NAND Outputs
- Single 5-V Supply
- Dual Channel Operation
- Compatible With TTL
- Short-Circuit Protection
- High-Current Outputs
- Common and Individual Output Controls
- Clamp Diodes at Inputs and Outputs
- Easily Adaptable to SN55114 and SN75114 Applications
- Designed for Use With SN55115 and SN75115

description

The SN55113 and SN75113 dual differential line drivers with 3-state outputs are designed to provide all the features of the SN55114 and SN75114 line drivers with the added feature of driver output controls. Individual controls are provided for each output pair, as well as a common control for both output pairs. If any output

is low, the associated output is in a high-impedance state and the output can neither drive nor load the bus. This permits many devices to be connected together on the same transmission line for party-line applications.

The output stages are similar to TTL totem-pole outputs, but with the sink outputs, YS and ZS, and the corresponding active pullup terminals, YP and ZP, available on adjacent package pins.

The SN55113 is characterized for operation over the full military temperature range of -55°C to 125°C . The SN75113 is characterized for operation over the temperature range of 0°C to 70°C .

SN55113 . . . J OR W PACKAGE
SN75113 . . . N PACKAGE
(TOP VIEW)

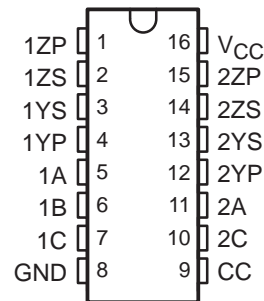

SN55113 . . . FK PACKAGE
(TOP VIEW)

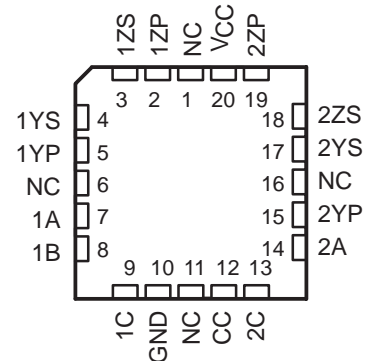

NC – No internal connection



Please be aware that an important notice concerning availability, standard warranty, and use in critical applications of Texas Instruments semiconductor products and disclaimers thereto appears at the end of this data sheet.

PRODUCTION DATA information is current as of publication date. Products conform to specifications per the terms of Texas Instruments standard warranty. Production processing does not necessarily include testing of all parameters.

 **TEXAS
INSTRUMENTS**

POST OFFICE BOX 655303 • DALLAS, TEXAS 75265

Copyright © 1997, Texas Instruments Incorporated

SN55113, SN75113 DUAL DIFFERENTIAL LINE DRIVERS

SLLS070C – SEPTEMBER 1973 – REVISED MARCH 1997

FUNCTION TABLE

INPUTS		OUTPUTS			
OUTPUT C	CONTROL CC	DATA		AND Y	NAND Z
		A	B†		
L	X	X	X	Z	Z
X	L	X	X	Z	Z
H	H	L	X	L	H
H	H	X	L	L	H
H	H	H	H	H	L

H = high level, L = low level, X = irrelevant,

Z = high impedance (off)

† B input and 4th line of function table are applicable only to driver number 1.

logic symbol†

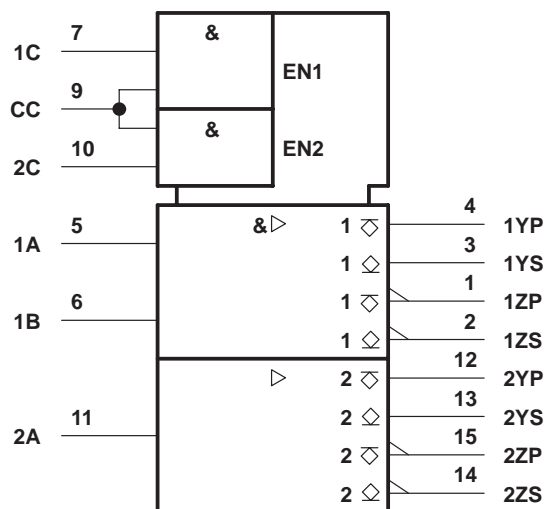

logic diagram (positive logic)

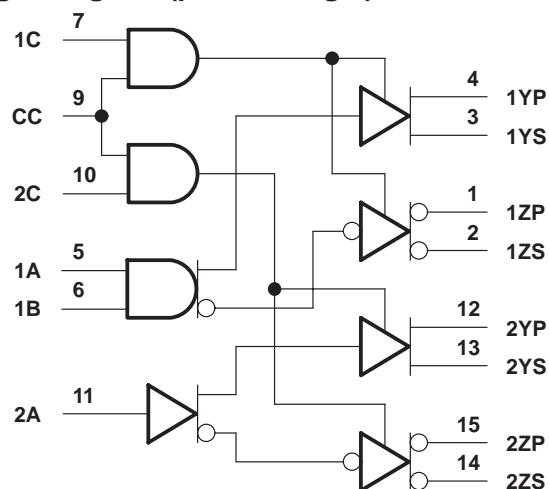

† This symbol is in accordance with ANSI/IEEE Std 91-1984 and IEC Publication 617-12.

Pin numbers shown are for the J, N, and W packages.

SN55113, SN75113 DUAL DIFFERENTIAL LINE DRIVERS

SLLS070C – SEPTEMBER 1973 – REVISED MARCH 1997

schematic

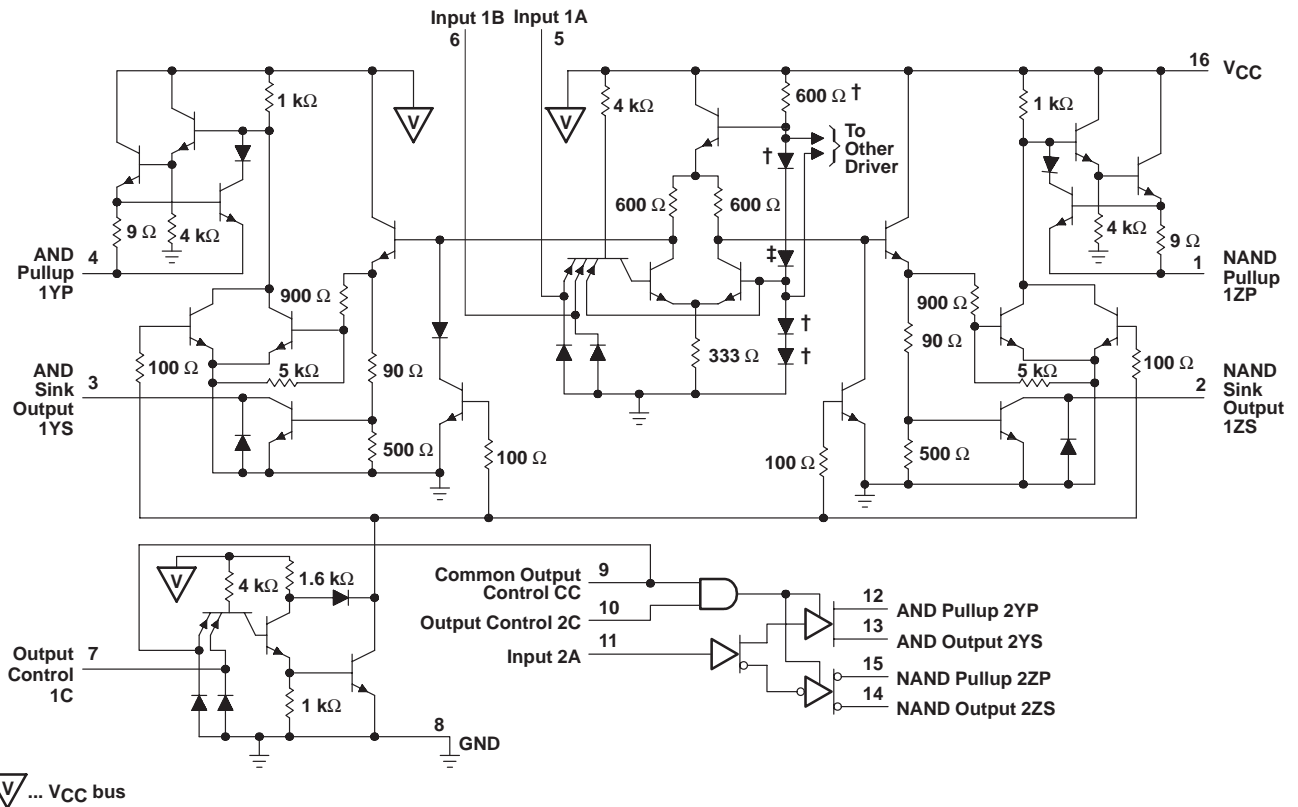

† These components are common to both drivers. Resistor values shown are nominal and in ohms.

absolute maximum ratings over operating free-air temperature range (unless otherwise noted)‡

Supply voltage, V_{CC} (see Note 1)	7 V
Input voltage, V_I	5.5 V
Off-state voltage applied to open-collector outputs	12 V
Continuous total power dissipation (see Note 2)	See Dissipation Rating Table
Operating free-air temperature range, T_A : SN55113	-55°C to 125°C
SN75113	0°C to 70°C
Storage temperature range, T_{Stg}	-65°C to 150°C
Lead temperature 1,6 mm (1/16 inch) from case for 10 seconds: N package	260°C
Case temperature for 60 seconds: FK package	260°C
Lead temperature 1,6 mm (1/16 inch) from case for 60 seconds: J or W package	300°C

‡ Stresses beyond those listed under "absolute maximum ratings" may cause permanent damage to the device. These are stress ratings only, and functional operation of the device at these or any other conditions beyond those indicated under "recommended operating conditions" is not implied. Exposure to absolute-maximum-rated conditions for extended periods may affect device reliability.

DISSIPATION RATING TABLE

PACKAGE	$T_A \leq 25^\circ\text{C}$ POWER RATING	DERATING FACTOR ABOVE $T_A = 25^\circ\text{C}$	$T_A = 70^\circ\text{C}$ POWER RATING	$T_A = 125^\circ\text{C}$ POWER RATING
FK	1375 mW	11.0 mW/°C	880 mW	275 mW
J	1375 mW	11.0 mW/°C	880 mW	275 mW
N	1150 mW	9.2 mW/°C	736 mW	N/A
W	1000 mW	8.0 mW/°C	640 mW	200 mW

SN55113, SN75113 DUAL DIFFERENTIAL LINE DRIVERS

SLLS070C – SEPTEMBER 1973 – REVISED MARCH 1997

recommended operating conditions

	SN55113			SN75113			UNIT
	MIN	NOM	MAX	MIN	NOM	MAX	
Supply voltage, V_{CC}	4.5	5	5.5	4.75	5	5.25	V
High-level input voltage, V_{IH}	2			2			V
Low-level input voltage, V_{IL}	0.8			0.8			V
High-level output current, I_{OH}	-40			-40			mA
Low-level output current, I_{OL}	40			40			mA
Operating free-air temperature, T_A	-55			125			°C

electrical characteristics over recommended operating free-air temperature range (unless otherwise noted)

PARAMETER		TEST CONDITIONS†		SN55113			SN75113			UNIT
				MIN	TYP‡	MAX	MIN	TYP‡	MAX	
V_{IK}	Input clamp voltage	$V_{CC} = \text{MIN}$, $I_I = -12 \text{ mA}$		-0.9	-1.5		-0.9	-1.5	V	
V_{OH}	High-level output voltage	$V_{CC} = \text{MIN}$, $V_{IL} = 0.8 \text{ V}$	$V_{IH} = 2 \text{ V}$	$I_{OH} = -10 \text{ mA}$	2.4	3.4	2.4	3.4	V	
				$I_{OH} = -40 \text{ mA}$	2	3.0	2	3.0		
V_{OL}	Low-level output voltage	$V_{CC} = \text{MIN}$, $I_{OL} = 40 \text{ mA}$	$V_{IH} = 2 \text{ V}$, $V_{IL} = 0.8 \text{ V}$	0.23	0.4		0.23	0.4	V	
V_{OK}	Output clamp voltage	$V_{CC} = \text{MAX}$, $I_O = -40 \text{ mA}$		-1.1	-1.5		-1.1	-1.5	V	
$I_{O(\text{off})}$	Off-state open-collector output current	$V_{CC} = \text{MAX}$	$V_{OH} = 12 \text{ V}$	$T_A = 25^\circ\text{C}$	1	10			μA	
				$T_A = 125^\circ\text{C}$		200				
			$V_{OH} = 5.25 \text{ V}$	$T_A = 25^\circ\text{C}$			1	10		
				$T_A = 70^\circ\text{C}$				20		
I_{OZ}	Off-state (high-impedance-state) output current	$V_{CC} = \text{MAX}$, Output controls at 0.8 V	$T_A = 25^\circ\text{C}$, $V_O = 0 \text{ to } V_{CC}$		± 10		± 10	μA		
					-150		-20			
			$T_A = \text{MAX}$	$V_O = 0$		± 80			± 20	
				$V_O = 0.4 \text{ V}$		± 80			± 20	
				$V_O = 2.4 \text{ V}$		80			20	
I_I	Input current at maximum input voltage	A, B, C	$V_{CC} = \text{MAX}$, $V_I = 5.5 \text{ V}$		1		1	mA		
		CC			2		2			
I_{IH}	High-level input current	A, B, C	$V_{CC} = \text{MAX}$, $V_I = 2.4 \text{ V}$		40		40	μA		
		CC			80		80			
I_{IL}	Low-level input current	A, B, C	$V_{CC} = \text{MAX}$, $V_I = 0.4 \text{ V}$		-1.6		-1.6	mA		
		CC			-3.2		-3.2			
I_{OS}	Short-circuit output current§	$V_{CC} = \text{MAX}$, $V_O = 0$, $T_A = 25^\circ\text{C}$		-40	-90	-120	-40	-90	-120	mA
I_{CC}	Supply current (both drivers)	All inputs at 0 V , No load, $T_A = 25^\circ\text{C}$		$V_{CC} = \text{MAX}$	47	65	47	65	mA	
				$V_{CC} = 7 \text{ V}$	65	85	65	85		

† All parameters with the exception of off-state open-collector output current are measured with the active pullup connected to the sink output. For conditions shown as MIN or MAX, use the appropriate value specified under recommended operating conditions.

‡ All typical values are at $T_A = 25^\circ\text{C}$ and $V_{CC} = 5 \text{ V}$, with the exception of V_{CC} at 7 V .

§ Only one output should be shorted at a time, and duration of the short-circuit should not exceed one second.



switching characteristics, $V_{CC} = 5\text{ V}$, $C_L = 30\text{ pF}$, $T_A = 25^\circ\text{C}$

PARAMETER	TEST CONDITIONS	SN55113			SN75113			UNIT
		MIN	TYP	MAX	MIN	TYP	MAX	
t_{PLH} Propagation delay time, low-to-high level output	See Figure 1		13	20		13	30	ns
t_{PHL} Propagation delay time, high-to-low-level output			12	20		12	30	
t_{PZH} Output enable time to high level	$R_L = 180\ \Omega$, See Figure 2		7	15		7	20	ns
t_{PZL} Output enable time to low level	$R_L = 250\ \Omega$, See Figure 3		14	30		14	40	ns
t_{PHZ} Output disable time from high level	$R_L = 180\ \Omega$, See Figure 2		10	20		10	30	ns
t_{PLZ} Output disable time from low level	$R_L = 250\ \Omega$, See Figure 3		17	35		17	35	ns

PARAMETER MEASUREMENT INFORMATION

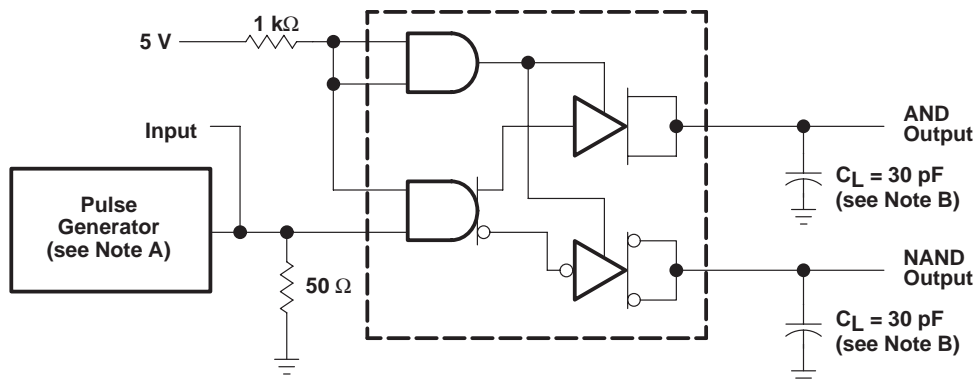

TEST CIRCUIT

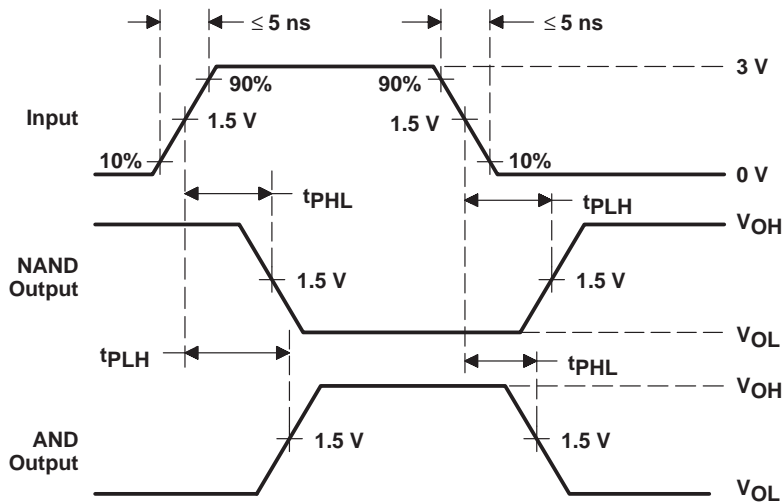

VOLTAGE WAVEFORMS

- NOTES: A. The pulse generator has the following characteristics: $Z_O = 50\ \Omega$, $PRR \leq 500\text{ kHz}$, $t_w = 100\text{ ns}$.
B. C_L includes probe and jig capacitance.

Figure 1. Test Circuit and Voltage Waveforms t_{PLH} and t_{PHL}

PARAMETER MEASUREMENT INFORMATION

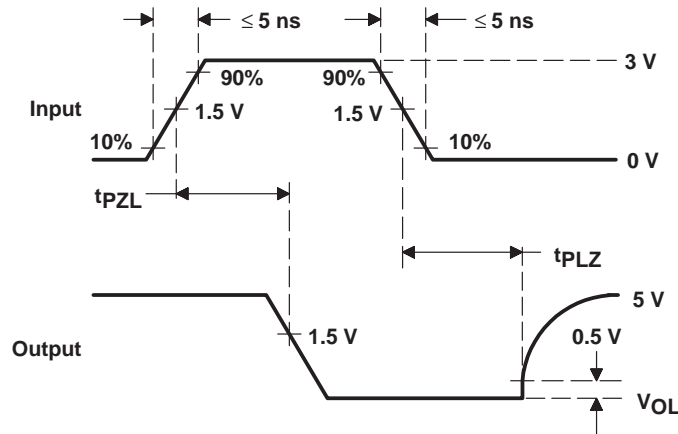
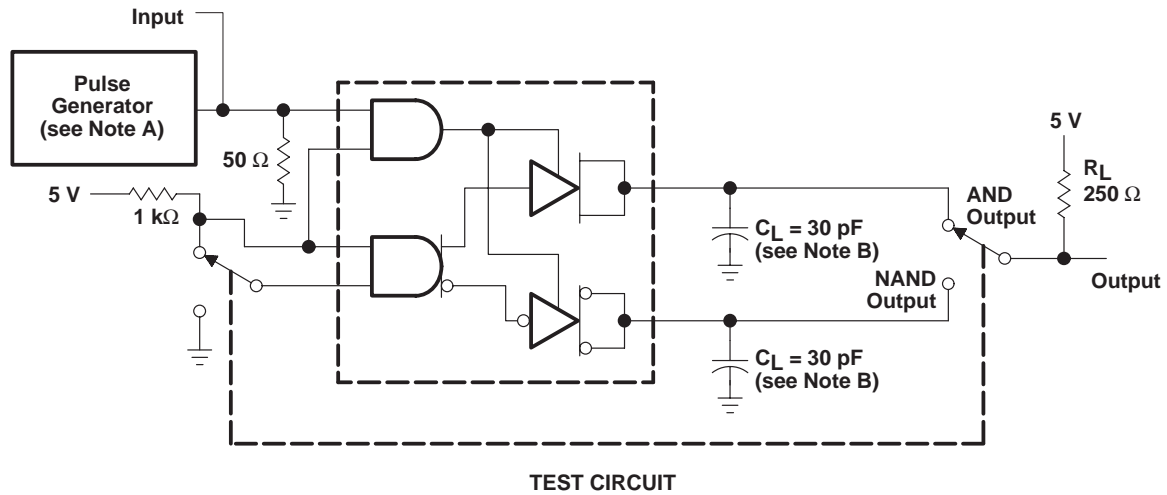

VOLTAGE WAVEFORMS

- NOTES: A. The pulse generator has the following characteristics: $Z_O = 50 \Omega$, $PRR \leq 500$ kHz, $t_W = 100$ ns.
 B. C_L includes probe and jig capacitance.

Figure 3. Test Circuit and Voltage Waveforms, t_{pZL} and t_{PLZ}

SN55113, SN75113 DUAL DIFFERENTIAL LINE DRIVERS

SLLS070C – SEPTEMBER 1973 – REVISED MARCH 1997

TYPICAL CHARACTERISTICS†

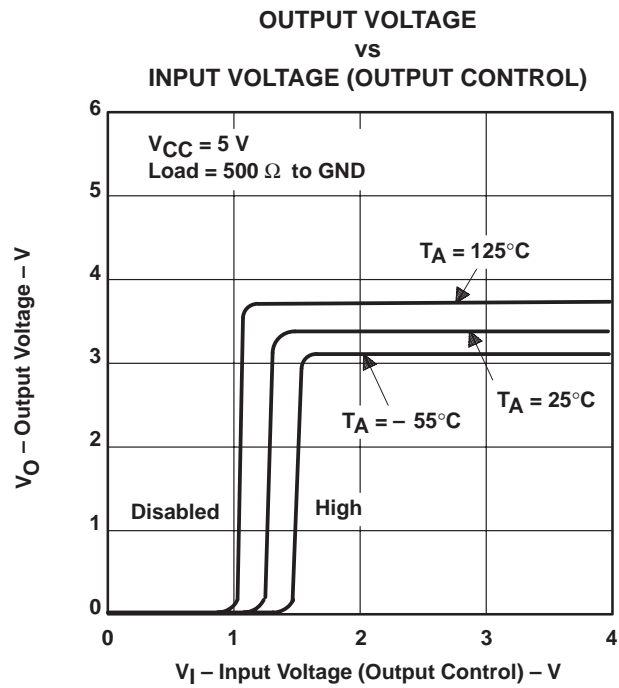
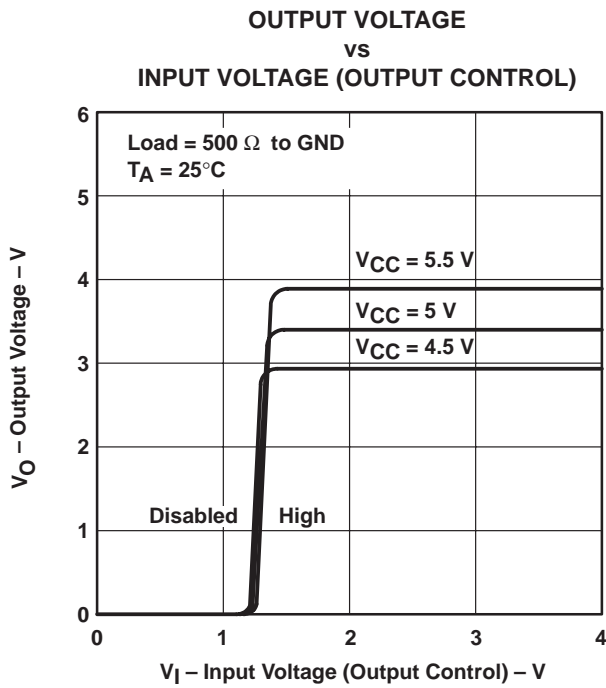
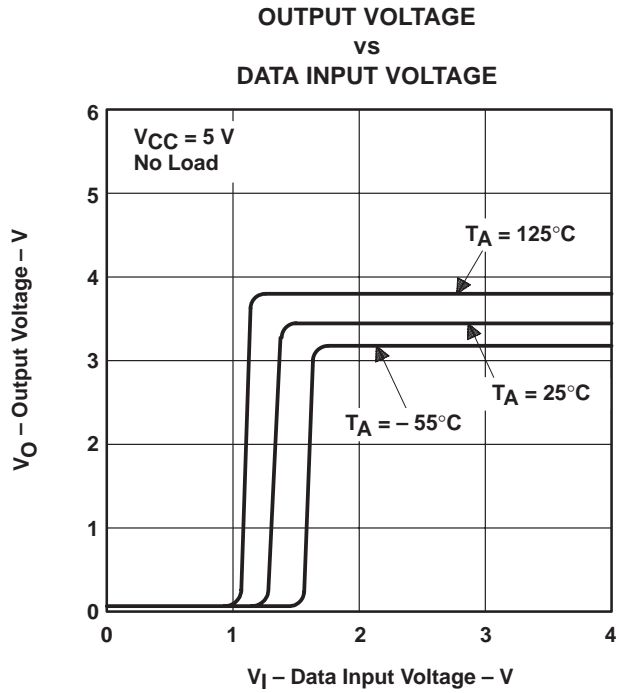
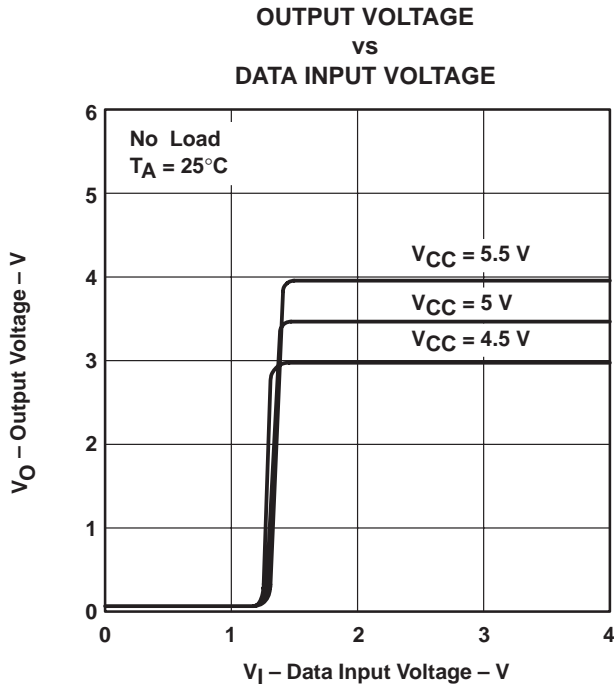

† Data for temperatures below 0°C and above 70°C and for supply voltages below 4.75 V and above 5.25 V are applicable to SN55113 circuits only. These parameters were measured with the active pullup connected to the sink output.

TYPICAL CHARACTERISTICS†

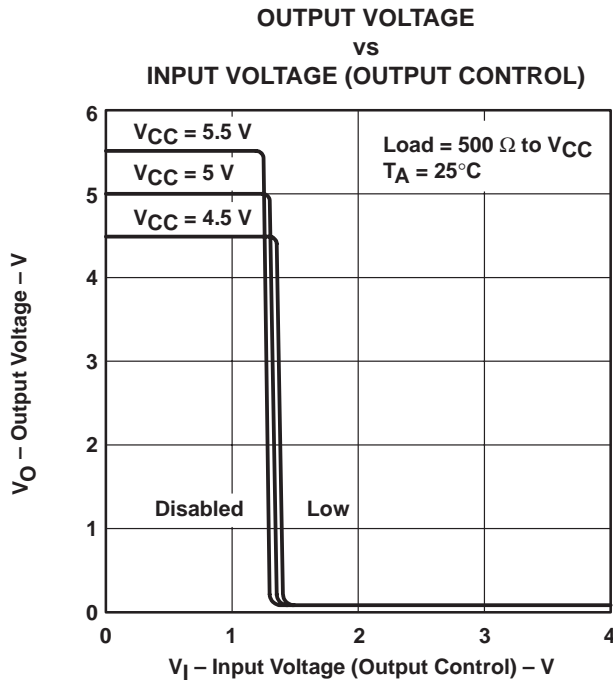

Figure 8

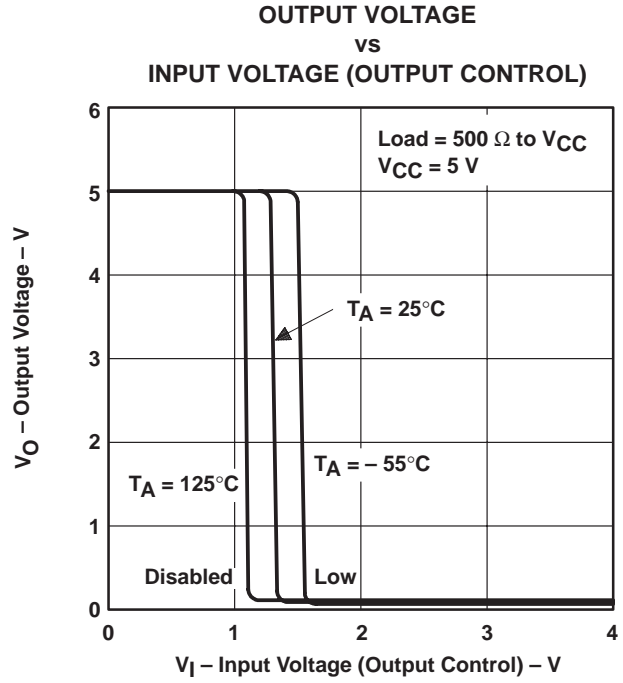

Figure 9

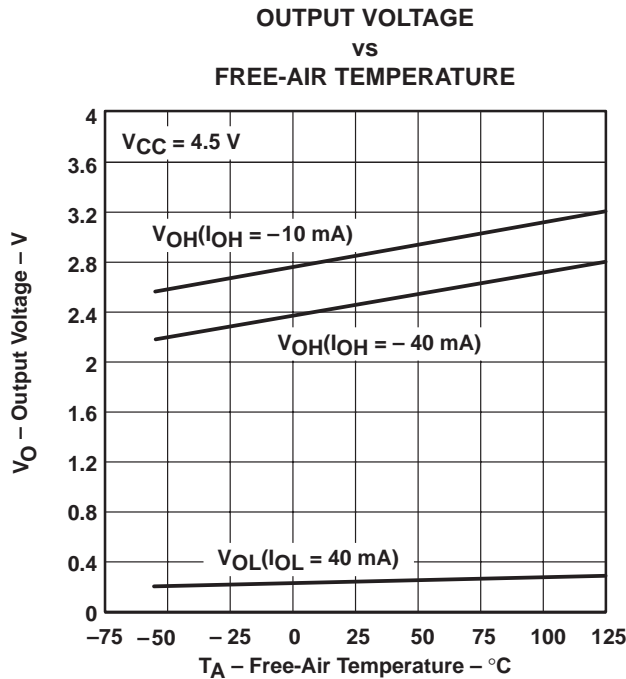

Figure 10

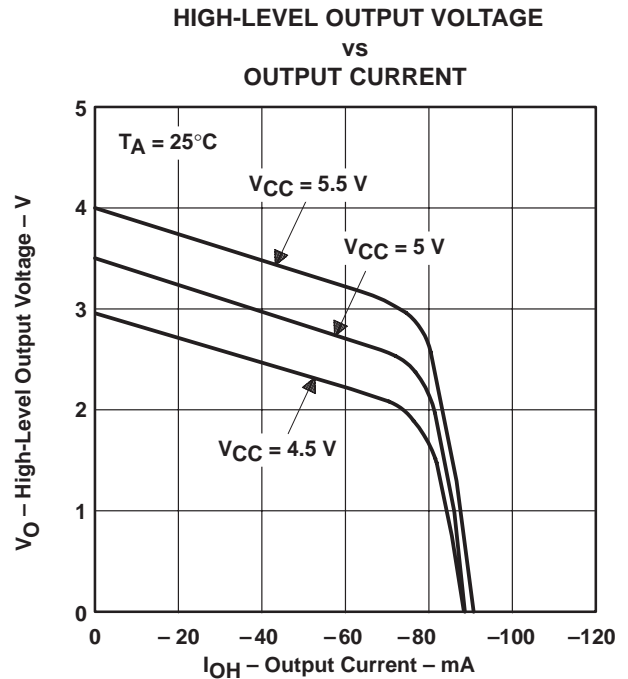

Figure 11

† Data for temperatures below 0°C and above 70°C and for supply voltages below 4.75 V and above 5.25 V are applicable to SN55113 circuits only. These parameters were measured with the active pullup connected to the sink output.

SN55113, SN75113 DUAL DIFFERENTIAL LINE DRIVERS

SLLS070C – SEPTEMBER 1973 – REVISED MARCH 1997

TYPICAL CHARACTERISTICS†

LOW-LEVEL OUTPUT VOLTAGE
vs
OUTPUT CURRENT

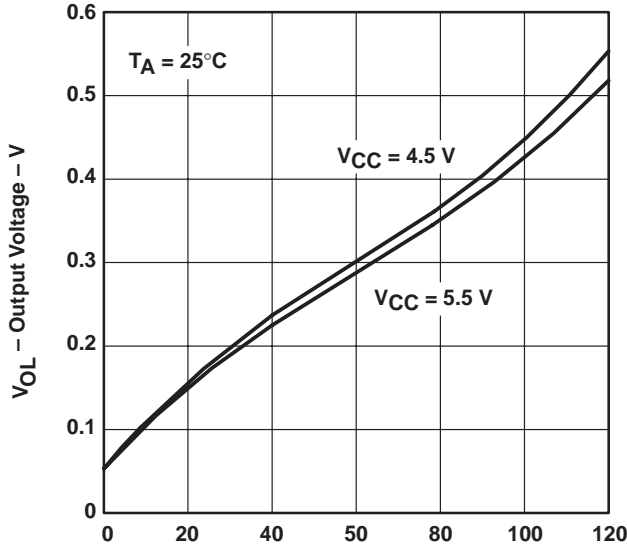

Figure 12

SUPPLY CURRENT
(BOTH DRIVERS)
vs
SUPPLY VOLTAGE

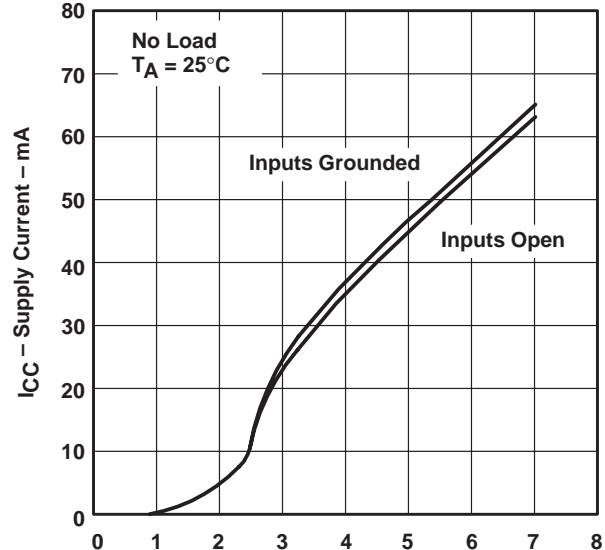

Figure 13

SUPPLY CURRENT
(BOTH DRIVERS)
vs
OUTPUT CURRENT

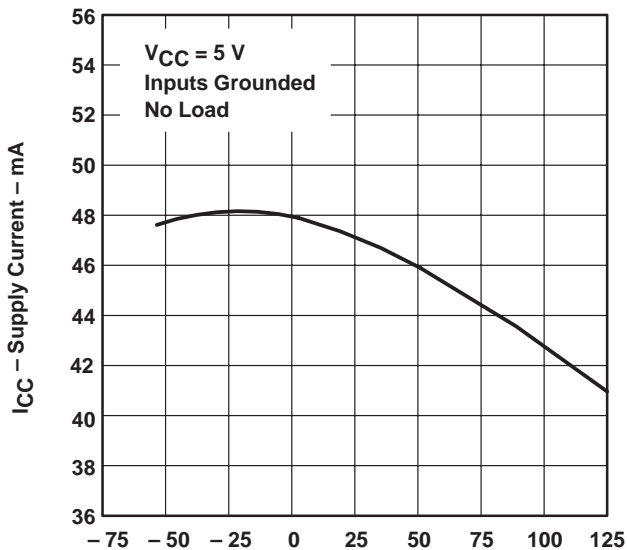

Figure 14

SUPPLY CURRENT
(BOTH DRIVERS)
vs
SUPPLY VOLTAGE

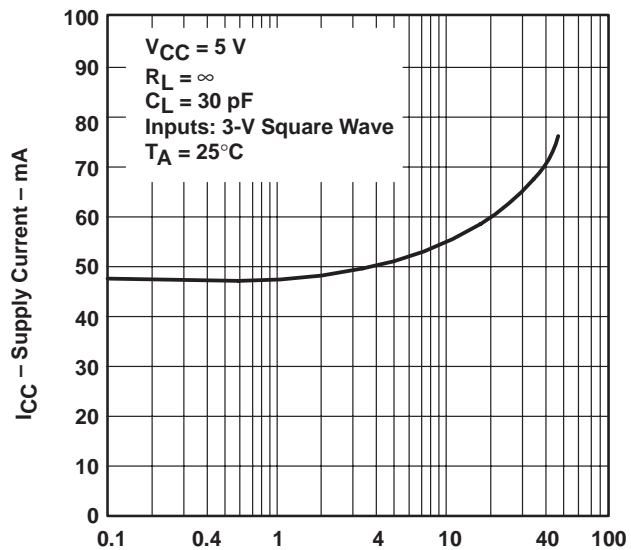
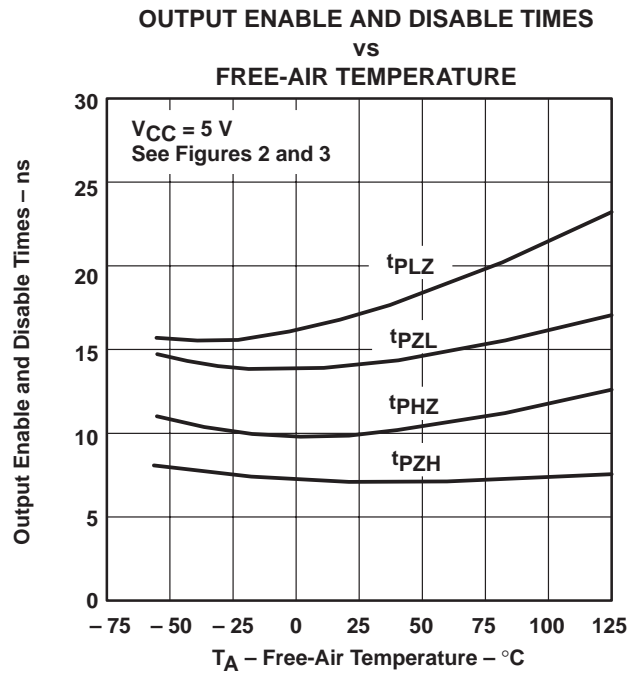
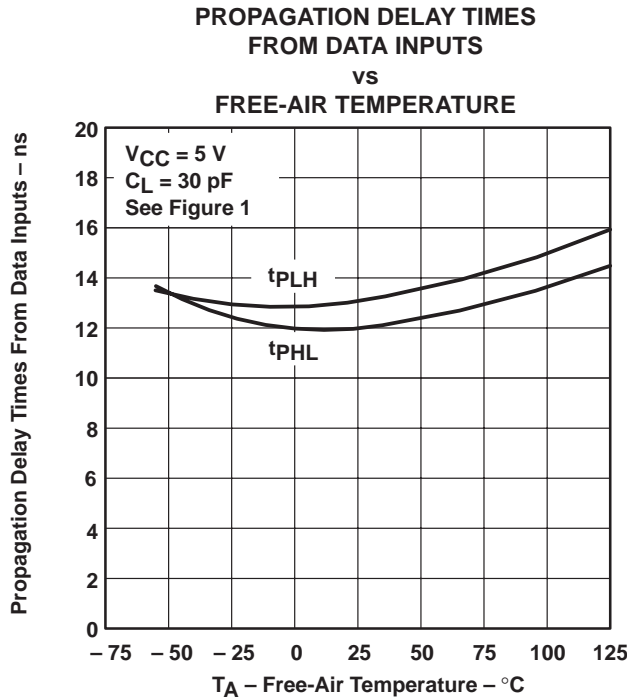

Figure 15

† Data for temperatures below 0°C and above 70°C and for supply voltages below 4.75 V and above 5.25 V are applicable to SN55113 circuits only. These parameters were measured with the active pullup connected to the sink output.

TYPICAL CHARACTERISTICS†



† Data for temperatures below 0°C and above 70°C and for supply voltages below 4.75 V and above 5.25 V are applicable to SN55113 circuits only. These parameters were measured with the active pullup connected to the sink output.

APPLICATION INFORMATION

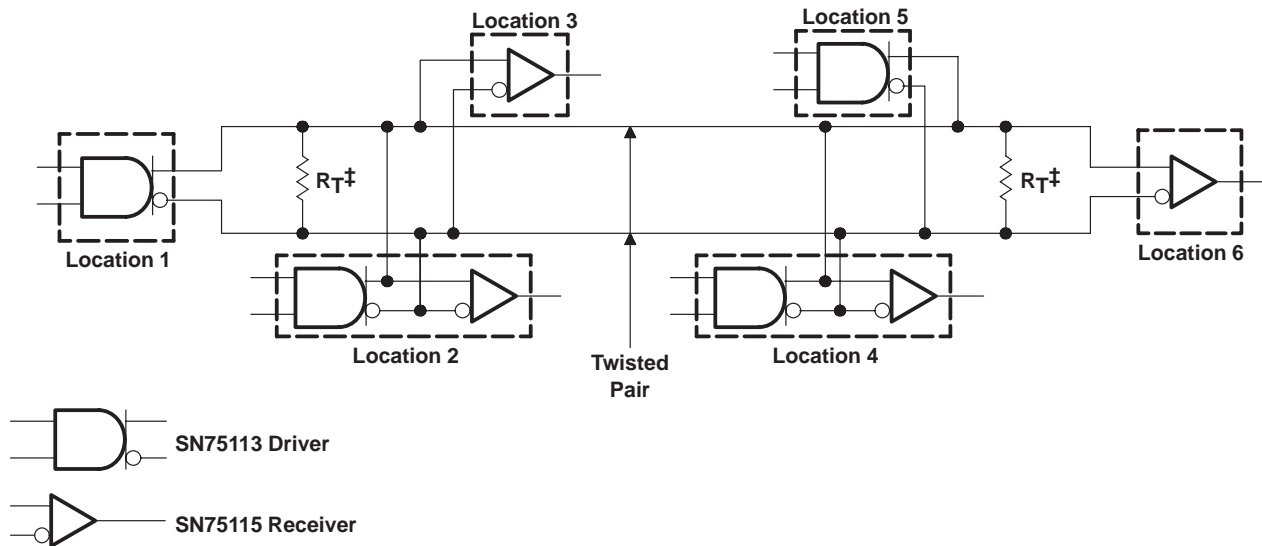

‡ $R_T = Z_O$. A capacitor may be connected in series with R_T to reduce power dissipation.

Figure 18. Basic Party-Line or Data-Bus Differential Data Transmission

PACKAGING INFORMATION

Orderable Device	Status ⁽¹⁾	Package Type	Package Drawing	Pins	Package Qty	Eco Plan ⁽²⁾	Lead/Ball Finish	MSL Peak Temp ⁽³⁾
5962-88744012A	ACTIVE	LCCC	FK	20	1	None	POST-PLATE	Level-NC-NC-NC
5962-8874401EA	ACTIVE	CDIP	J	16	1	None	A42 SNPB	Level-NC-NC-NC
5962-8874401FA	ACTIVE	CFP	W	16	1	None	A42 SNPB	Level-NC-NC-NC
JM38510/10405BEA	ACTIVE	CDIP	J	16	1	None	A42 SNPB	Level-NC-NC-NC
SN55113J	ACTIVE	CDIP	J	16	1	None	A42 SNPB	Level-NC-NC-NC
SN75113D	OBSOLETE	SOIC	D	16		None	Call TI	Call TI
SN75113DR	OBSOLETE	SOIC	D	16		None	Call TI	Call TI
SN75113N	ACTIVE	PDIP	N	16	25	Pb-Free (RoHS)	CU NIPDAU	Level-NC-NC-NC
SN75113NSR	ACTIVE	SO	NS	16	2000	Pb-Free (RoHS)	CU NIPDAU	Level-2-260C-1 YEAR/ Level-1-235C-UNLIM
SNJ55113FK	ACTIVE	LCCC	FK	20	1	None	POST-PLATE	Level-NC-NC-NC
SNJ55113J	ACTIVE	CDIP	J	16	1	None	A42 SNPB	Level-NC-NC-NC
SNJ55113W	ACTIVE	CFP	W	16	1	None	A42 SNPB	Level-NC-NC-NC

⁽¹⁾ The marketing status values are defined as follows:

ACTIVE: Product device recommended for new designs.

LIFEBUY: TI has announced that the device will be discontinued, and a lifetime-buy period is in effect.

NRND: Not recommended for new designs. Device is in production to support existing customers, but TI does not recommend using this part in a new design.

PREVIEW: Device has been announced but is not in production. Samples may or may not be available.

OBSOLETE: TI has discontinued the production of the device.

⁽²⁾ Eco Plan - May not be currently available - please check <http://www.ti.com/productcontent> for the latest availability information and additional product content details.

None: Not yet available Lead (Pb-Free).

Pb-Free (RoHS): TI's terms "Lead-Free" or "Pb-Free" mean semiconductor products that are compatible with the current RoHS requirements for all 6 substances, including the requirement that lead not exceed 0.1% by weight in homogeneous materials. Where designed to be soldered at high temperatures, TI Pb-Free products are suitable for use in specified lead-free processes.

Green (RoHS & no Sb/Br): TI defines "Green" to mean "Pb-Free" and in addition, uses package materials that do not contain halogens, including bromine (Br) or antimony (Sb) above 0.1% of total product weight.

⁽³⁾ MSL, Peak Temp. -- The Moisture Sensitivity Level rating according to the JEDEC industry standard classifications, and peak solder temperature.

Important Information and Disclaimer: The information provided on this page represents TI's knowledge and belief as of the date that it is provided. TI bases its knowledge and belief on information provided by third parties, and makes no representation or warranty as to the accuracy of such information. Efforts are underway to better integrate information from third parties. TI has taken and continues to take reasonable steps to provide representative and accurate information but may not have conducted destructive testing or chemical analysis on incoming materials and chemicals. TI and TI suppliers consider certain information to be proprietary, and thus CAS numbers and other limited information may not be available for release.

In no event shall TI's liability arising out of such information exceed the total purchase price of the TI part(s) at issue in this document sold by TI to Customer on an annual basis.

IMPORTANT NOTICE

Texas Instruments Incorporated and its subsidiaries (TI) reserve the right to make corrections, modifications, enhancements, improvements, and other changes to its products and services at any time and to discontinue any product or service without notice. Customers should obtain the latest relevant information before placing orders and should verify that such information is current and complete. All products are sold subject to TI's terms and conditions of sale supplied at the time of order acknowledgment.

TI warrants performance of its hardware products to the specifications applicable at the time of sale in accordance with TI's standard warranty. Testing and other quality control techniques are used to the extent TI deems necessary to support this warranty. Except where mandated by government requirements, testing of all parameters of each product is not necessarily performed.

TI assumes no liability for applications assistance or customer product design. Customers are responsible for their products and applications using TI components. To minimize the risks associated with customer products and applications, customers should provide adequate design and operating safeguards.

TI does not warrant or represent that any license, either express or implied, is granted under any TI patent right, copyright, mask work right, or other TI intellectual property right relating to any combination, machine, or process in which TI products or services are used. Information published by TI regarding third-party products or services does not constitute a license from TI to use such products or services or a warranty or endorsement thereof. Use of such information may require a license from a third party under the patents or other intellectual property of the third party, or a license from TI under the patents or other intellectual property of TI.

Reproduction of information in TI data books or data sheets is permissible only if reproduction is without alteration and is accompanied by all associated warranties, conditions, limitations, and notices. Reproduction of this information with alteration is an unfair and deceptive business practice. TI is not responsible or liable for such altered documentation.

Resale of TI products or services with statements different from or beyond the parameters stated by TI for that product or service voids all express and any implied warranties for the associated TI product or service and is an unfair and deceptive business practice. TI is not responsible or liable for any such statements.

Following are URLs where you can obtain information on other Texas Instruments products and application solutions:

Products		Applications	
Amplifiers	amplifier.ti.com	Audio	www.ti.com/audio
Data Converters	dataconverter.ti.com	Automotive	www.ti.com/automotive
DSP	dsp.ti.com	Broadband	www.ti.com/broadband
Interface	interface.ti.com	Digital Control	www.ti.com/digitalcontrol
Logic	logic.ti.com	Military	www.ti.com/military
Power Mgmt	power.ti.com	Optical Networking	www.ti.com/opticalnetwork
Microcontrollers	microcontroller.ti.com	Security	www.ti.com/security
		Telephony	www.ti.com/telephony
		Video & Imaging	www.ti.com/video
		Wireless	www.ti.com/wireless

Mailing Address: Texas Instruments
Post Office Box 655303 Dallas, Texas 75265