

# CY54FCT273T, CY74FCT273T 8-BIT REGISTERS

SCCS020A – MARCH 1995 – REVISED OCTOBER 2001

- **Function, Pinout, and Drive Compatible With FCT and F Logic**
- **Reduced  $V_{OH}$  (Typically = 3.3 V) Versions of Equivalent FCT Functions**
- **Edge-Rate Control Circuitry for Significantly Improved Noise Characteristics**
- **$I_{off}$  Supports Partial-Power-Down Mode Operation**
- **Matched Rise and Fall Times**
- **ESD Protection Exceeds JESD 22**
  - 2000-V Human-Body Model (A114-A)
  - 200-V Machine Model (A115-A)
  - 1000-V Charged-Device Model (C101)
- **Fully Compatible With TTL Input and Output Logic Levels**
- **CY54FCT273T**
  - 32-mA Output Sink Current
  - 12-mA Output Source Current
- **CY74FCT273T**
  - 64-mA Output Sink Current
  - 32-mA Output Source Current

## description

The 'FCT273T devices consist of eight edge-triggered D-type flip-flops with individual D inputs and Q outputs. The common buffered-clock (CP) and master-reset ( $\overline{MR}$ ) inputs load and reset all flip-flops simultaneously. These devices are edge-triggered registers. The state of each D input (one setup time before the low-to-high clock transition) is transferred to the corresponding flip-flop's Q output. All outputs are forced low by a low logic level on the  $\overline{MR}$  input.

This device is fully specified for partial-power-down applications using  $I_{off}$ . The  $I_{off}$  circuitry disables the outputs, preventing damaging current backflow through the device when it is powered down.

**CY54FCT273T . . . D PACKAGE  
CY74FCT273T . . . Q OR SO PACKAGE  
(TOP VIEW)**

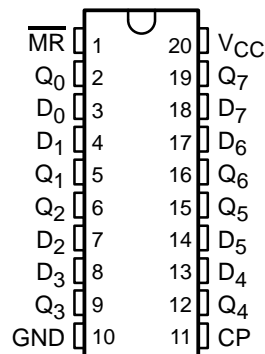

**CY54FCT273T . . . L PACKAGE  
(TOP VIEW)**

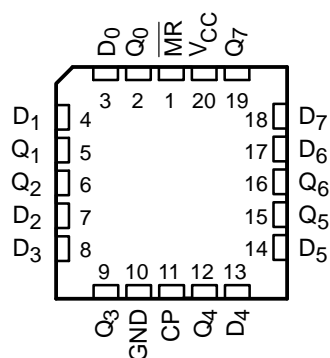

Please be aware that an important notice concerning availability, standard warranty, and use in critical applications of Texas Instruments semiconductor products and disclaimers thereto appears at the end of this data sheet.

PRODUCTION DATA information is current as of publication date. Products conform to specifications per the terms of Texas Instruments standard warranty. Production processing does not necessarily include testing of all parameters.



POST OFFICE BOX 655303 • DALLAS, TEXAS 75265

Copyright © 2001, Texas Instruments Incorporated

# CY54FCT273T, CY74FCT273T 8-BIT REGISTERS

SCCS020A – MARCH 1995 – REVISED OCTOBER 2001

## ORDERING INFORMATION

T <sub>A</sub>	PACKAGE†		SPEED (ns)	ORDERABLE PART NUMBER	TOP-SIDE MARKING
-40°C to 85°C	QSOP – Q	Tape and reel	5.8	CY74FCT273CTQCT	FCT273C
	SOIC – SO	Tube	5.8	CY74FCT273CTSOC	FCT273C
		Tape and reel	5.8	CY74FCT273CTSOCT	
	QSOP – Q	Tape and reel	7.2	CY74FCT273ATQCT	FCT273A
		SOIC – SO	Tube	7.2	CY74FCT273ATSOC
	Tape and reel		7.2	CY74FCT273ATSOCT	
-55°C to 125°C	QSOP – Q	Tape and reel	13	CY74FCT273TQCT	FCT273
	SOIC – SO	Tube	13	CY74FCT273TSOC	FCT273
		Tape and reel	13	CY74FCT273TSOCT	
	LCC – L	Tube	8.3	CY54FCT273ATLMB	

† Package drawings, standard packing quantities, thermal data, symbolization, and PCB design guidelines are available at [www.ti.com/sc/package](http://www.ti.com/sc/package).

## FUNCTION TABLE

INPUTS			OUTPUT Q	OPERATING MODE
$\overline{MR}$	CP	D		
L	X	X	L	Reset (clear)
H	↑	h	H	Load '1'
H	↑	l	L	Load '0'

H = High logic level steady state, h = High logic level one setup time prior to low-to-high clock transition, L = Low logic level steady state, l = Low logic level one setup time prior to the low-to-high transition, X = Don't care, ↑ = Low-to-high clock transition

## logic diagram (positive logic)

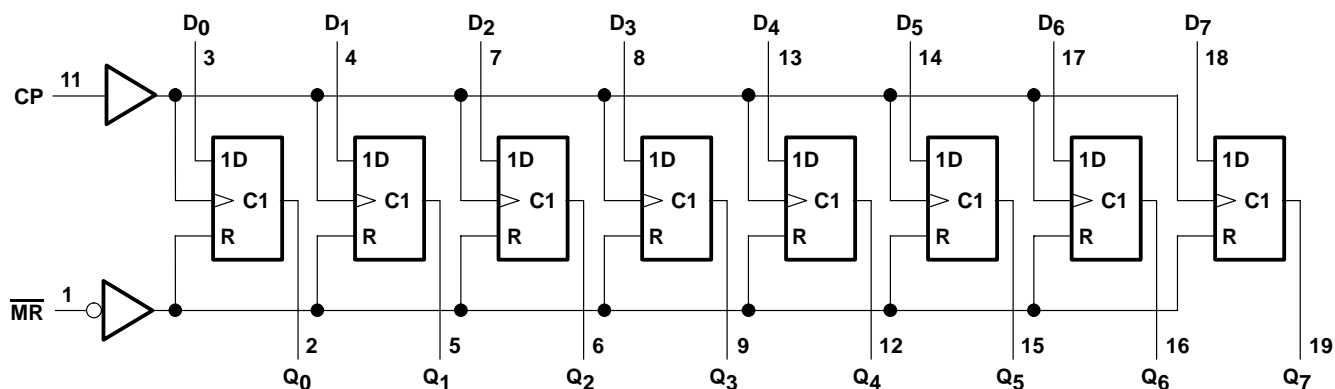

**absolute maximum ratings over operating free-air temperature range (unless otherwise noted)†**

Supply voltage range to ground potential .....	–0.5 V to 7 V
DC input voltage range .....	–0.5 V to 7 V
DC output voltage range .....	–0.5 V to 7 V
DC output current (maximum sink current/pin) .....	120 mA
Package thermal impedance, $\theta_{JA}$ (see Note 1): Q package .....	68°C/W
SO package .....	58°C/W
Ambient temperature range with power applied, $T_A$ .....	–65°C to 135°C
Storage temperature range, $T_{stg}$ .....	–65°C to 150°C

† Stresses beyond those listed under “absolute maximum ratings” may cause permanent damage to the device. These are stress ratings only, and functional operation of the device at these or any other conditions beyond those indicated under “recommended operating conditions” is not implied. Exposure to absolute-maximum-rated conditions for extended periods may affect device reliability.

NOTE 1: The package thermal impedance is calculated in accordance with JESD 51-7.

**recommended operating conditions (see Note 2)**

	CY54FCT273T			CY74FCT273T			UNIT
	MIN	NOM	MAX	MIN	NOM	MAX	
$V_{CC}$ Supply voltage	4.5	5	5.5	4.75	5	5.25	V
$V_{IH}$ High-level input voltage	2			2			V
$V_{IL}$ Low-level input voltage	0.8			0.8			V
$I_{OH}$ High-level output current	–12			–32			mA
$I_{OL}$ Low-level output current	32			64			mA
$T_A$ Operating free-air temperature	–55		125	–40		85	°C

NOTE 2: All unused inputs of the device must be held at  $V_{CC}$  or GND to ensure proper device operation.

# CY54FCT273T, CY74FCT273T

## 8-BIT REGISTERS

SCCS020A – MARCH 1995 – REVISED OCTOBER 2001

electrical characteristics over recommended operating free-air temperature range (unless otherwise noted)

PARAMETER	TEST CONDITIONS	CY54FCT273T			CY74FCT273T			UNIT
		MIN	TYP†	MAX	MIN	TYP†	MAX	
V <sub>IK</sub>	V <sub>CC</sub> = 4.5 V, I <sub>IN</sub> = -18 mA	-0.7	-1.2					V
	V <sub>CC</sub> = 4.75 V, I <sub>IN</sub> = -18 mA				-0.7	-1.2		
V <sub>OH</sub>	V <sub>CC</sub> = 4.5 V, I <sub>OH</sub> = -12 mA	2.4	3.3					V
	V <sub>CC</sub> = 4.75 V	I <sub>OH</sub> = -32 mA			2			
		I <sub>OH</sub> = -15 mA			2.4	3.3		
V <sub>OL</sub>	V <sub>CC</sub> = 4.5 V, I <sub>OL</sub> = 32 mA	0.3	0.55					V
	V <sub>CC</sub> = 4.75 V, I <sub>OL</sub> = 64 mA				0.3	0.55		
V <sub>hys</sub>	All inputs	0.2			0.2			V
I <sub>I</sub>	V <sub>CC</sub> = 5.5 V, V <sub>IN</sub> = V <sub>CC</sub>			5				μA
	V <sub>CC</sub> = 5.25 V, V <sub>IN</sub> = V <sub>CC</sub>					5		
I <sub>IH</sub>	V <sub>CC</sub> = 5.5 V, V <sub>IN</sub> = 2.7 V			±1				μA
	V <sub>CC</sub> = 5.25 V, V <sub>IN</sub> = 2.7 V					±1		
I <sub>IL</sub>	V <sub>CC</sub> = 5.5 V, V <sub>IN</sub> = 0.5 V			±1				μA
	V <sub>CC</sub> = 5.25 V, V <sub>IN</sub> = 0.5 V					±1		
I <sub>off</sub>	V <sub>CC</sub> = 0 V, V <sub>OUT</sub> = 4.5 V			±1			±1	μA
I <sub>OS</sub> ‡	V <sub>CC</sub> = 5.5 V, V <sub>OUT</sub> = 0 V	-60	-120	-225				mA
	V <sub>CC</sub> = 5.25 V, V <sub>OUT</sub> = 0 V				-60	-120	-225	
I <sub>CC</sub>	V <sub>CC</sub> = 5.5 V, V <sub>IN</sub> ≤ 0.2 V, V <sub>IN</sub> ≥ V <sub>CC</sub> - 0.2 V	0.1	0.2					mA
	V <sub>CC</sub> = 5.25 V, V <sub>IN</sub> ≤ 0.2 V, V <sub>IN</sub> ≥ V <sub>CC</sub> - 0.2 V				0.1	0.2		
ΔI <sub>CC</sub>	V <sub>CC</sub> = 5.5 V, V <sub>IN</sub> = 3.4 V§, f <sub>1</sub> = 0, Outputs open	0.5	2					mA
	V <sub>CC</sub> = 5.25 V, V <sub>IN</sub> = 3.4 V§, f <sub>1</sub> = 0, Outputs open				0.5	2		

† Typical values are at V<sub>CC</sub> = 5 V, T<sub>A</sub> = 25°C.

‡ Not more than one output should be shorted at a time. Duration of short should not exceed one second. The use of high-speed test apparatus and/or sample-and-hold techniques are preferable to minimize internal chip heating and more accurately reflect operational values. Otherwise, prolonged shorting of a high output can raise the chip temperature well above normal and cause invalid readings in other parametric tests. In any sequence of parameter tests, I<sub>OS</sub> tests should be performed last.

§ Per TTL-driven input (V<sub>IN</sub> = 3.4 V); all other inputs at V<sub>CC</sub> or GND



electrical characteristics over recommended operating free-air temperature range (unless otherwise noted) (continued)

PARAMETER	TEST CONDITIONS		CY54FCT273T		CY74FCT273T		UNIT	
			MIN	TYP†	MAX	MIN		TYP†
$I_{CCD}^{\ddagger}$	$V_{CC} = 5.5\text{ V}$ , Outputs open, One bit switching at 50% duty cycle, $\overline{MR} = V_{CC}$ , $V_{IN} \leq 0.2\text{ V}$ or $V_{IN} \geq V_{CC} - 0.2\text{ V}$		0.06	0.12			mA/ MHz	
	$V_{CC} = 5.25\text{ V}$ , Outputs open, One bit switching at 50% duty cycle, $\overline{MR} = V_{CC}$ , $V_{IN} \leq 0.2\text{ V}$ or $V_{IN} \geq V_{CC} - 0.2\text{ V}$				0.06	0.12		
$I_C^{\#}$	$V_{CC} = 5.5\text{ V}$ , $f_0 = 10\text{ MHz}$ , Outputs open, $\overline{MR} = V_{CC}$	One bit switching at $f_1 = 2.5\text{ MHz}$ at 50% duty cycle	$V_{IN} \leq 0.2\text{ V}$ or $V_{IN} \geq V_{CC} - 0.2\text{ V}$	0.7	1.4		mA	
			$V_{IN} = 3.4\text{ V}$ or GND	1.2	3.4			
		Eight bits switching at $f_1 = 2.5\text{ MHz}$ at 50% duty cycle	$V_{IN} \leq 0.2\text{ V}$ or $V_{IN} \geq V_{CC} - 0.2\text{ V}$	1.6	3.2 $\parallel$			
	$V_{IN} = 3.4\text{ V}$ or GND		3.9	12.2 $\parallel$				
	$V_{CC} = 5.25\text{ V}$ , $f_0 = 10\text{ MHz}$ , Outputs open, $\overline{MR} = V_{CC}$	One bit switching at $f_1 = 5\text{ MHz}$ at 50% duty cycle	$V_{IN} \leq 0.2\text{ V}$ or $V_{IN} \geq V_{CC} - 0.2\text{ V}$			0.7		1.4
			$V_{IN} = 3.4\text{ V}$ or GND			1.2		3.4
Eight bits switching at $f_1 = 5\text{ MHz}$ at 50% duty cycle		$V_{IN} \leq 0.2\text{ V}$ or $V_{IN} \geq V_{CC} - 0.2\text{ V}$			1.6	3.2 $\parallel$		
		$V_{IN} = 3.4\text{ V}$ or GND			3.9	12.2 $\parallel$		
$C_i$			5	10	5	10	pF	
$C_o$			9	12	9	12	pF	

† Typical values are at  $V_{CC} = 5\text{ V}$ ,  $T_A = 25^\circ\text{C}$ .

$\ddagger$  This parameter is derived for use in total power-supply calculations.

$$\# I_C = I_{CC} + \Delta I_{CC} \times D_H \times N_T + I_{CCD} (f_0/2 + f_1 \times N_1)$$

Where:

$I_C$  = Total supply current

$I_{CC}$  = Power-supply current with CMOS input levels

$\Delta I_{CC}$  = Power-supply current for a TTL high input ( $V_{IN} = 3.4\text{ V}$ )

$D_H$  = Duty cycle for TTL inputs high

$N_T$  = Number of TTL inputs at  $D_H$

$I_{CCD}$  = Dynamic current caused by an input transition pair (HLH or LHL)

$f_0$  = Clock frequency for registered devices, otherwise zero

$f_1$  = Input signal frequency

$N_1$  = Number of inputs changing at  $f_1$

All currents are in milliamperes and all frequencies are in megahertz.

$\parallel$  Values for these conditions are examples of the  $I_{CC}$  formula.

# CY54FCT273T, CY74FCT273T 8-BIT REGISTERS

SCCS020A – MARCH 1995 – REVISED OCTOBER 2001

**timing requirements over recommended operating free-air temperature range (unless otherwise noted) (see Figure 1)**

			CY74FCT273T		CY54FCT273AT		CY74FCT273AT		CY74FCT273CT		UNIT
			MIN	MAX	MIN	MAX	MIN	MAX	MIN	MAX	
t <sub>w</sub>	Pulse duration, high or low	CP	6		6		6		6		ns
		$\overline{\text{MR}}$	6		6		6		6		
t <sub>su</sub>	Setup time, high or low	D before CP↑	2		2		2		2		ns
t <sub>h</sub>	Hold time, high or low	D after CP↑	1.5		1.5		1.5		1.5		ns
t <sub>rec</sub>	Recovery time	$\overline{\text{MR}}$ after CP↑	2		2.5		2		2		ns

**switching characteristics over operating free-air temperature range (see Figure 1)**

PARAMETER	FROM (INPUT)	TO (OUTPUT)	CY74FCT273T		CY54FCT273AT		CY74FCT273AT		CY74FCT273CT		UNIT
			MIN	MAX	MIN	MAX	MIN	MAX	MIN	MAX	
t <sub>PLH</sub>	CP	Q	2	13	2	8.3	2	7.2	2	5.8	ns
t <sub>PHL</sub>			2	13	2	8.3	2	7.2	2	5.8	
t <sub>PLH</sub>	$\overline{\text{MR}}$	Q	2	13	2	8.3	2	7.2	2	6.1	ns
t <sub>PHL</sub>			2	13	2	8.3	2	7.2	2	6.1	



PARAMETER MEASUREMENT INFORMATION

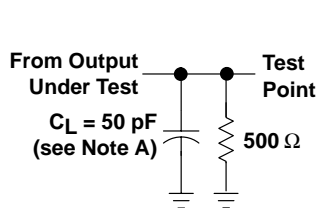

LOAD CIRCUIT FOR  
TOTEM-POLE OUTPUTS

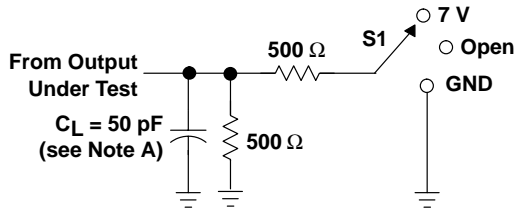

LOAD CIRCUIT FOR  
3-STATE OUTPUTS

TEST	S1
$t_{PLH}/t_{PHL}$	Open
$t_{PLZ}/t_{PZL}$	7 V
$t_{PHZ}/t_{PZH}$	Open

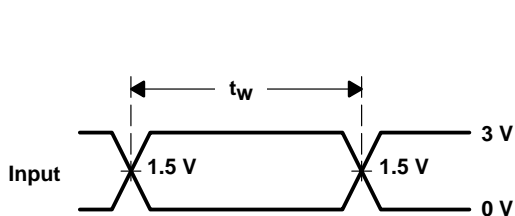

VOLTAGE WAVEFORMS  
PULSE DURATION

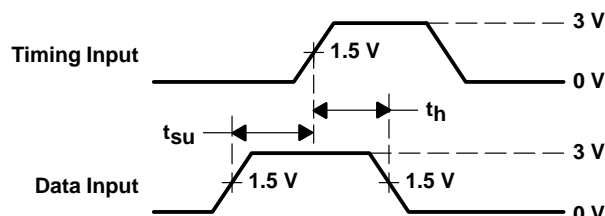

VOLTAGE WAVEFORMS  
SETUP AND HOLD TIMES

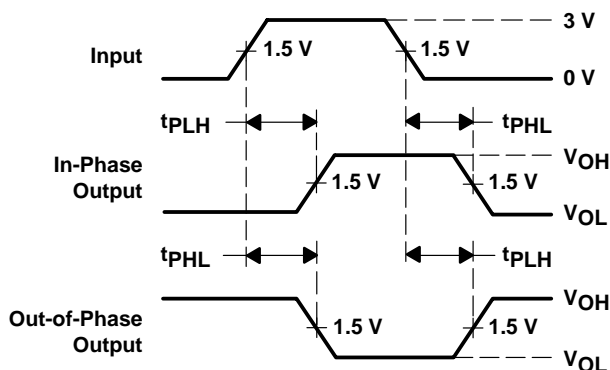

VOLTAGE WAVEFORMS  
PROPAGATION DELAY TIMES  
INVERTING AND NONINVERTING OUTPUTS

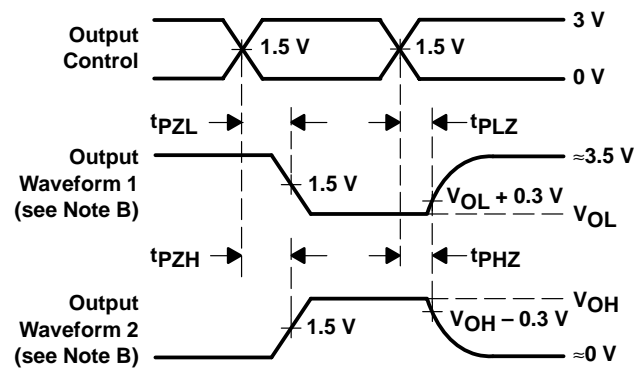

VOLTAGE WAVEFORMS  
ENABLE AND DISABLE TIMES  
LOW- AND HIGH-LEVEL ENABLING

- NOTES: A.  $C_L$  includes probe and jig capacitance.  
B. Waveform 1 is for an output with internal conditions such that the output is low except when disabled by the output control. Waveform 2 is for an output with internal conditions such that the output is high except when disabled by the output control.  
C. The outputs are measured one at a time with one input transition per measurement.

Figure 1. Load Circuit and Voltage Waveforms

## IMPORTANT NOTICE

Texas Instruments Incorporated and its subsidiaries (TI) reserve the right to make corrections, modifications, enhancements, improvements, and other changes to its products and services at any time and to discontinue any product or service without notice. Customers should obtain the latest relevant information before placing orders and should verify that such information is current and complete. All products are sold subject to TI's terms and conditions of sale supplied at the time of order acknowledgment.

TI warrants performance of its hardware products to the specifications applicable at the time of sale in accordance with TI's standard warranty. Testing and other quality control techniques are used to the extent TI deems necessary to support this warranty. Except where mandated by government requirements, testing of all parameters of each product is not necessarily performed.

TI assumes no liability for applications assistance or customer product design. Customers are responsible for their products and applications using TI components. To minimize the risks associated with customer products and applications, customers should provide adequate design and operating safeguards.

TI does not warrant or represent that any license, either express or implied, is granted under any TI patent right, copyright, mask work right, or other TI intellectual property right relating to any combination, machine, or process in which TI products or services are used. Information published by TI regarding third-party products or services does not constitute a license from TI to use such products or services or a warranty or endorsement thereof. Use of such information may require a license from a third party under the patents or other intellectual property of the third party, or a license from TI under the patents or other intellectual property of TI.

Reproduction of information in TI data books or data sheets is permissible only if reproduction is without alteration and is accompanied by all associated warranties, conditions, limitations, and notices. Reproduction of this information with alteration is an unfair and deceptive business practice. TI is not responsible or liable for such altered documentation.

Resale of TI products or services with statements different from or beyond the parameters stated by TI for that product or service voids all express and any implied warranties for the associated TI product or service and is an unfair and deceptive business practice. TI is not responsible or liable for any such statements.

### Mailing Address:

Texas Instruments  
Post Office Box 655303  
Dallas, Texas 75265