

SN54CBT16244, SN74CBT16244 16-BIT FET BUS SWITCHES

SCDS0311 – MAY 1996 – REVISED OCTOBER 2000

- Members of Texas Instruments' Widebus™ Family
- Standard '16244-Type Pinout
- 5-Ω Switch Connection Between Two Ports
- TTL-Compatible Input Levels

description

The 'CBT16244 devices provide 16 bits of high-speed TTL-compatible bus switching in a standard '16244 device pinout. The low on-state resistance of the switch allows connections to be made with minimal propagation delay.

These devices are organized as four 4-bit low-impedance switches with separate output-enable (\overline{OE}) inputs. When \overline{OE} is low, the switch is on, and data can flow from port A to port B, or vice versa. When \overline{OE} is high, the switch is open, and the high-impedance state exists between the two ports.

SN54CBT16244 . . . WD PACKAGE
SN74CBT16244 . . . DGG, DGV, OR DL PACKAGE
(TOP VIEW)

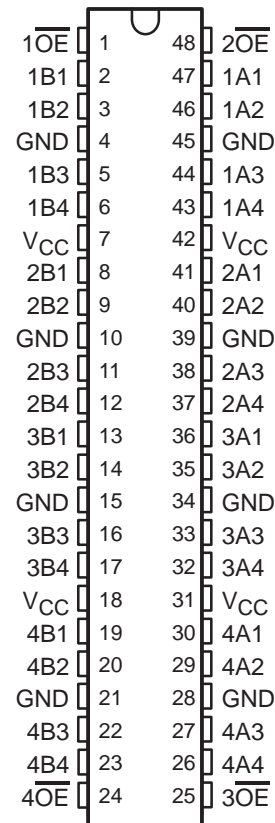

ORDERING INFORMATION

TA	PACKAGE†		ORDERABLE PART NUMBER	TOP-SIDE MARKING
-40°C to 85°C	SSOP – DL	Tube	SN74CBT16244DL	CBT16244
		Tape and reel	SN74CBT16244DLR	
	TSSOP – DGG	Tape and reel	SN74CBT16244DGGR	CBT16244
	TVSOP – DGV	Tape and reel	SN74CBT16244DGVR	CY244
-55°C to 125°C	CFP – WD	Tube	SNJ54CBT16244WD	SNJ54CBT16244WD

† Package drawings, standard packing quantities, thermal data, symbolization, and PCB design guidelines are available at www.ti.com/sc/package.

FUNCTION TABLE
(each 4-bit bus switch)

INPUT \overline{OE}	OUTPUTS A, B
L	A port = B port
H	Disconnect



Please be aware that an important notice concerning availability, standard warranty, and use in critical applications of Texas Instruments semiconductor products and disclaimers thereto appears at the end of this data sheet.

Widebus is a trademark of Texas Instruments.

PRODUCTION DATA information is current as of publication date. Products conform to specifications per the terms of Texas Instruments standard warranty. Production processing does not necessarily include testing of all parameters.

 **TEXAS
INSTRUMENTS**

POST OFFICE BOX 655303 • DALLAS, TEXAS 75265

Copyright © 2000, Texas Instruments Incorporated
On products compliant to MIL-PRF-38535, all parameters are tested unless otherwise noted. On all other products, production processing does not necessarily include testing of all parameters.

SN54CBT16244, SN74CBT16244 16-BIT FET BUS SWITCHES

SCDS0311 – MAY 1996 – REVISED OCTOBER 2000

electrical characteristics over recommended operating free-air temperature range (unless otherwise noted)

PARAMETER	TEST CONDITIONS		SN54CBT16244			SN74CBT16244			UNIT		
			MIN	TYP†	MAX	MIN	TYP†	MAX			
V_{IK}	$V_{CC} = 4.5\text{ V}$, $I_I = -18\text{ mA}$		-1.2			-1.2			V		
I_I	$V_{CC} = 0$	$V_I = 5.5\text{ V}$	10			10			μA		
	$V_{CC} = 5.5\text{ V}$	$V_I = 5.5\text{ V or GND}$	± 1			± 1					
I_{CC}	$V_{CC} = 5.5\text{ V}$, $V_I = V_{CC}\text{ or GND}$		$I_O = 0$,		3.2			3	μA		
$\Delta I_{CC}\ddagger$	Control inputs	$V_{CC} = 5.5\text{ V}$, Other inputs at $V_{CC}\text{ or GND}$		One input at 3.4 V,		2.5			2.5	mA	
C_i	Control inputs	$V_I = 3\text{ V or 0}$		2.5			2.5			pF	
$C_{io(OFF)}$	$V_O = 3\text{ V or 0}$,		$\overline{OE} = V_{CC}$		4.5			4.5			pF
$r_{on}\S$	$V_{CC} = 4\text{ V}$,		$V_I = 2.4\text{ V}$, $I_I = 15\text{ mA}$		20		20			Ω	
	$V_{CC} = 4.5\text{ V}$		$V_I = 0$, $I_I = 64\text{ mA}$		5 10		5 7				
			$V_I = 0$, $I_I = 30\text{ mA}$		5 10		5 7				
			$V_I = 2.4\text{ V}$, $I_I = 15\text{ mA}$		8 14		8 12				

† All typical values are at $V_{CC} = 5\text{ V}$, $T_A = 25^\circ\text{C}$.

‡ This is the increase in supply current for each input that is at the specified TTL voltage level rather than V_{CC} or GND.

§ Measured by the voltage drop between the A and B terminals at the indicated current through the switch. On-state resistance is determined by the lower of the voltages of the two (A or B) terminals.

switching characteristics over recommended operating free-air temperature range, $C_L = 50\text{ pF}$ (unless otherwise noted) (see Figure 1)

PARAMETER	FROM (INPUT)	TO (OUTPUT)	SN54CBT16244				SN74CBT16244				UNIT
			$V_{CC} = 4\text{ V}$		$V_{CC} = 5\text{ V} \pm 0.5\text{ V}$		$V_{CC} = 4\text{ V}$		$V_{CC} = 5\text{ V} \pm 0.5\text{ V}$		
			MIN	MAX	MIN	MAX	MIN	MAX	MIN	MAX	
$t_{pd}\parallel$	A or B	B or A			0.8*		0.35		0.25		ns
t_{en}	\overline{OE}	A or B	10.3		1 9.2		5.5		1 5.1		ns
t_{dis}	\overline{OE}	A or B	9.7		1 8.2		5.2		1 5.4		ns

* On products compliant to MIL-PRF-38535, this parameter is not production tested.

¶ The propagation delay is the calculated RC time constant of the typical on-state resistance of the switch and the specified load capacitance, when driven by an ideal voltage source (zero output impedance).

SN54CBT16244, SN74CBT16244 16-BIT FET BUS SWITCHES

SCDS0311 – MAY 1996 – REVISED OCTOBER 2000

PARAMETER MEASUREMENT INFORMATION

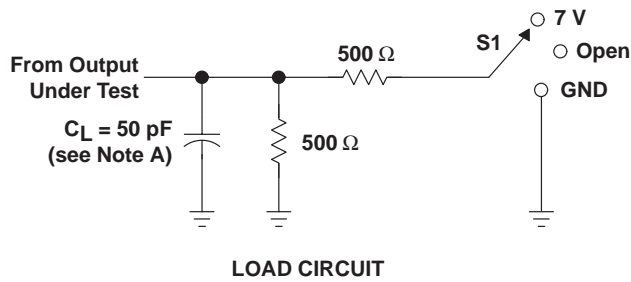

TEST	S1
t_{pd}	Open
t_{PLZ}/t_{PZL}	7 V
t_{PHZ}/t_{PZH}	Open

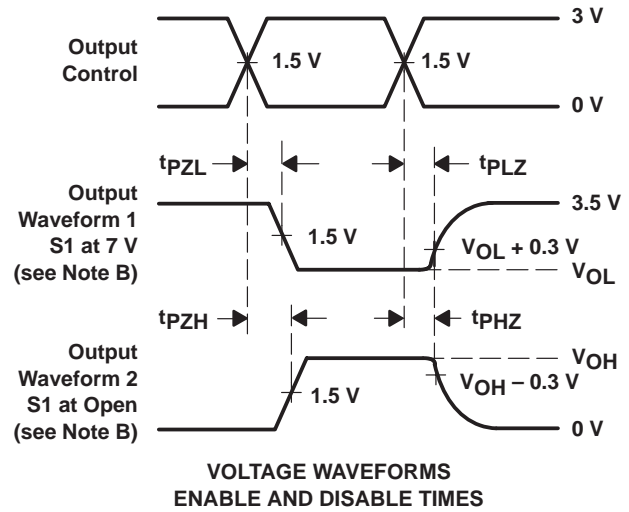
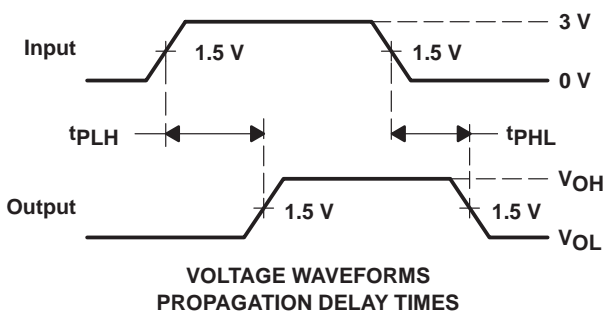

- NOTES:
- A. C_L includes probe and jig capacitance.
 - B. Waveform 1 is for an output with internal conditions such that the output is low except when disabled by the output control. Waveform 2 is for an output with internal conditions such that the output is high except when disabled by the output control.
 - C. All input pulses are supplied by generators having the following characteristics: $PRR \leq 10 \text{ MHz}$, $Z_O = 50 \Omega$, $t_r \leq 2.5 \text{ ns}$, $t_f \leq 2.5 \text{ ns}$.
 - D. The outputs are measured one at a time with one transition per measurement.
 - E. t_{PLZ} and t_{PHZ} are the same as t_{dis} .
 - F. t_{PZL} and t_{PZH} are the same as t_{en} .
 - G. t_{PLH} and t_{PHL} are the same as t_{pd} .

Figure 1. Load Circuit and Voltage Waveforms

PACKAGING INFORMATION

Orderable Device	Status ⁽¹⁾	Package Type	Package Drawing	Pins	Package Qty	Eco Plan ⁽²⁾	Lead/Ball Finish	MSL Peak Temp ⁽³⁾
5962-9855301QXA	ACTIVE	CFP	WD	48	1	None	Call TI	Level-NC-NC-NC
SN74CBT16244DGGR	ACTIVE	TSSOP	DGG	48	2000	Pb-Free (RoHS)	CU NIPDAU	Level-1-250C-UNLIM
SN74CBT16244DGVR	ACTIVE	TVSOP	DGV	48	2000	Pb-Free (RoHS)	CU NIPDAU	Level-1-250C-UNLIM
SN74CBT16244DL	ACTIVE	SSOP	DL	48	25	None	CU NIPDAU	Level-1-235C-UNLIM
SN74CBT16244DLR	ACTIVE	SSOP	DL	48	1000	None	CU NIPDAU	Level-1-235C-UNLIM
SNJ54CBT16244WD	ACTIVE	CFP	WD	48	1	None	Call TI	Level-NC-NC-NC

⁽¹⁾ The marketing status values are defined as follows:

ACTIVE: Product device recommended for new designs.

LIFEBUY: TI has announced that the device will be discontinued, and a lifetime-buy period is in effect.

NRND: Not recommended for new designs. Device is in production to support existing customers, but TI does not recommend using this part in a new design.

PREVIEW: Device has been announced but is not in production. Samples may or may not be available.

OBSOLETE: TI has discontinued the production of the device.

⁽²⁾ Eco Plan - May not be currently available - please check <http://www.ti.com/productcontent> for the latest availability information and additional product content details.

None: Not yet available Lead (Pb-Free).

Pb-Free (RoHS): TI's terms "Lead-Free" or "Pb-Free" mean semiconductor products that are compatible with the current RoHS requirements for all 6 substances, including the requirement that lead not exceed 0.1% by weight in homogeneous materials. Where designed to be soldered at high temperatures, TI Pb-Free products are suitable for use in specified lead-free processes.

Green (RoHS & no Sb/Br): TI defines "Green" to mean "Pb-Free" and in addition, uses package materials that do not contain halogens, including bromine (Br) or antimony (Sb) above 0.1% of total product weight.

⁽³⁾ MSL, Peak Temp. -- The Moisture Sensitivity Level rating according to the JEDEC industry standard classifications, and peak solder temperature.

Important Information and Disclaimer: The information provided on this page represents TI's knowledge and belief as of the date that it is provided. TI bases its knowledge and belief on information provided by third parties, and makes no representation or warranty as to the accuracy of such information. Efforts are underway to better integrate information from third parties. TI has taken and continues to take reasonable steps to provide representative and accurate information but may not have conducted destructive testing or chemical analysis on incoming materials and chemicals. TI and TI suppliers consider certain information to be proprietary, and thus CAS numbers and other limited information may not be available for release.

In no event shall TI's liability arising out of such information exceed the total purchase price of the TI part(s) at issue in this document sold by TI to Customer on an annual basis.

IMPORTANT NOTICE

Texas Instruments Incorporated and its subsidiaries (TI) reserve the right to make corrections, modifications, enhancements, improvements, and other changes to its products and services at any time and to discontinue any product or service without notice. Customers should obtain the latest relevant information before placing orders and should verify that such information is current and complete. All products are sold subject to TI's terms and conditions of sale supplied at the time of order acknowledgment.

TI warrants performance of its hardware products to the specifications applicable at the time of sale in accordance with TI's standard warranty. Testing and other quality control techniques are used to the extent TI deems necessary to support this warranty. Except where mandated by government requirements, testing of all parameters of each product is not necessarily performed.

TI assumes no liability for applications assistance or customer product design. Customers are responsible for their products and applications using TI components. To minimize the risks associated with customer products and applications, customers should provide adequate design and operating safeguards.

TI does not warrant or represent that any license, either express or implied, is granted under any TI patent right, copyright, mask work right, or other TI intellectual property right relating to any combination, machine, or process in which TI products or services are used. Information published by TI regarding third-party products or services does not constitute a license from TI to use such products or services or a warranty or endorsement thereof. Use of such information may require a license from a third party under the patents or other intellectual property of the third party, or a license from TI under the patents or other intellectual property of TI.

Reproduction of information in TI data books or data sheets is permissible only if reproduction is without alteration and is accompanied by all associated warranties, conditions, limitations, and notices. Reproduction of this information with alteration is an unfair and deceptive business practice. TI is not responsible or liable for such altered documentation.

Resale of TI products or services with statements different from or beyond the parameters stated by TI for that product or service voids all express and any implied warranties for the associated TI product or service and is an unfair and deceptive business practice. TI is not responsible or liable for any such statements.

Following are URLs where you can obtain information on other Texas Instruments products and application solutions:

Products		Applications	
Amplifiers	amplifier.ti.com	Audio	www.ti.com/audio
Data Converters	dataconverter.ti.com	Automotive	www.ti.com/automotive
DSP	dsp.ti.com	Broadband	www.ti.com/broadband
Interface	interface.ti.com	Digital Control	www.ti.com/digitalcontrol
Logic	logic.ti.com	Military	www.ti.com/military
Power Mgmt	power.ti.com	Optical Networking	www.ti.com/opticalnetwork
Microcontrollers	microcontroller.ti.com	Security	www.ti.com/security
		Telephony	www.ti.com/telephony
		Video & Imaging	www.ti.com/video
		Wireless	www.ti.com/wireless

Mailing Address: Texas Instruments
Post Office Box 655303 Dallas, Texas 75265