

FEATURES

- Member of the Texas Instruments Widebus+™ Family
- UBT™ Transceiver Combines D-Type Latches and D-Type Flip-Flops for Operation in Transparent, Latched, or Clocked Mode
- Operates From 1.65 V to 3.6 V
- Max t_{pd} of 3.9 ns at 3.3 V
- ± 24 -mA Output Drive at 3.3 V
- Bus Hold on Data Inputs Eliminates the Need for External Pullup/Pulldown Resistors
- Latch-Up Performance Exceeds 250 mA Per JESD 17
- ESD Protection Exceeds JESD 22
 - 2000-V Human-Body Model (A114-A)
 - 200-V Machine Model (A115-A)

DESCRIPTION/ORDERING INFORMATION

This 36-bit universal bus transceiver is designed for 1.65-V to 3.6-V V_{CC} operation.

This device can be used as two 18-bit transceivers or one 36-bit transceiver. Data flow in each direction is controlled by output enable (\overline{OEAB} and \overline{OEBA}), latch enable (\overline{LEAB} and \overline{LEBA}), and clock (\overline{CLKAB} and \overline{CLKBA}) inputs. For A-to-B data flow, the device operates in the transparent mode when \overline{LEAB} is high. When \overline{LEAB} is low, the A data is latched if \overline{CLKAB} is held at a high or low logic level. If \overline{LEAB} is low, the A data is stored in the latch/flip-flop on the low-to-high transition of \overline{CLKAB} . When \overline{OEAB} is high, the outputs are active. When \overline{OEAB} is low, the outputs are in the high-impedance state.

Data flow for B to A is similar to that of A to B, but uses \overline{OEBA} , \overline{LEBA} , and \overline{CLKBA} . The output enables are complementary (\overline{OEAB} is active high and \overline{OEBA} is active low).

To ensure the high-impedance state during power up or power down, \overline{OEBA} should be tied to V_{CC} through a pullup resistor, and \overline{OEAB} should be tied to GND through a pulldown resistor; the minimum value of the resistor is determined by the current-sinking capability of the driver.

Active bus-hold circuitry holds unused or undriven inputs at a valid logic state. Use of pullup or pulldown resistors with the bus-hold circuitry is not recommended.

ORDERING INFORMATION

| T_A | PACKAGE ⁽¹⁾ | | ORDERABLE PART NUMBER | TOP-SIDE MARKING |
|---------------|------------------------|---------------|-----------------------|------------------|
| -40°C to 85°C | LFBGA - GKF | Tape and reel | SN74ALVCH32501KR | ACH501 |
| | LFBGA - ZKF (Pb-free) | | 74ALVCH32501ZKFR | |

(1) Package drawings, standard packing quantities, thermal data, symbolization, and PCB design guidelines are available at www.ti.com/sc/package.



Please be aware that an important notice concerning availability, standard warranty, and use in critical applications of Texas Instruments semiconductor products and disclaimers thereto appears at the end of this data sheet.

Widebus+, UBT are trademarks of Texas Instruments.

SN74ALVCH32501
36-BIT UNIVERSAL BUS TRANSCEIVER
WITH 3-STATE OUTPUTS

SCES144G–OCTOBER 1998–REVISED OCTOBER 2004

GKF OR ZKF PACKAGE
(TOP VIEW)

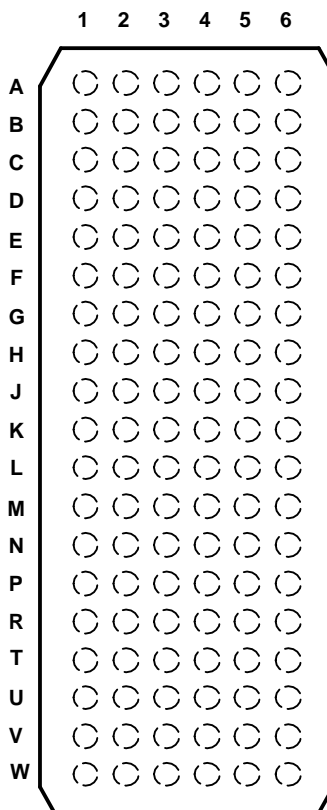

TERMINAL ASSIGNMENTS⁽¹⁾

| | 1 | 2 | 3 | 4 | 5 | 6 |
|----------|------|-------|---------------------|-----------------|--------|------|
| A | 1A2 | 1A1 | 1LEAB | 1CLKAB | 1B1 | 1B2 |
| B | 1A4 | 1A3 | 1OEAB | GND | 1B3 | 1B4 |
| C | 1A6 | 1A5 | GND | GND | 1B5 | 1B6 |
| D | 1A8 | 1A7 | V _{CC} | V _{CC} | 1B7 | 1B8 |
| E | 1A10 | 1A9 | GND | GND | 1B9 | 1B10 |
| F | 1A12 | 1A11 | GND | GND | 1B11 | 1B12 |
| G | 1A14 | 1A13 | V _{CC} | V _{CC} | 1B13 | 1B14 |
| H | 1A15 | 1A16 | GND | GND | 1B16 | 1B15 |
| J | 1A17 | 1A18 | 1 \overline{OEBA} | 1CLKBA | 1B18 | 1B17 |
| K | NC | 2LEAB | 1LEAB | GND | 2CLKAB | NC |
| L | 2A2 | 2A1 | 2OEAB | GND | 2B1 | 2B2 |
| M | 2A4 | 2A3 | GND | GND | 2B3 | 2B4 |
| N | 2A6 | 2A5 | V _{CC} | V _{CC} | 2B5 | 2B6 |
| P | 2A8 | 2A7 | GND | GND | 2B7 | 2B8 |
| R | 2A10 | 2A9 | GND | GND | 2B9 | 2B10 |
| T | 2A12 | 2A11 | V _{CC} | V _{CC} | 2B11 | 2B12 |
| U | 2A14 | 2A13 | GND | GND | 2B13 | 2B14 |
| V | 2A15 | 2A16 | 2 \overline{OEBA} | 2CLKBA | 2B16 | 2B15 |
| W | 2A17 | 2A18 | 2LEBA | GND | 2B18 | 2B17 |

(1) NC - No internal connection

FUNCTION TABLE⁽¹⁾

| INPUTS | | | | OUTPUT B |
|--------|------|-------|---|-------------------------------|
| OEAB | LEAB | CLKAB | A | |
| L | X | X | X | Z |
| H | H | X | L | L |
| H | H | X | H | H |
| H | L | ↑ | L | L |
| H | L | ↑ | H | H |
| H | L | H | X | B ₀ ⁽²⁾ |
| H | L | L | X | B ₀ ⁽³⁾ |

- (1) A-to-B data flow is shown; B-to-A flow is similar, but uses \overline{OEBA} , \overline{LEBA} , and \overline{CLKBA} .
- (2) Output level before the indicated steady-state input conditions were established, provided that \overline{CLKAB} was high before \overline{LEAB} went low
- (3) Output level before the indicated steady-state input conditions were established

LOGIC DIAGRAM (POSITIVE LOGIC)

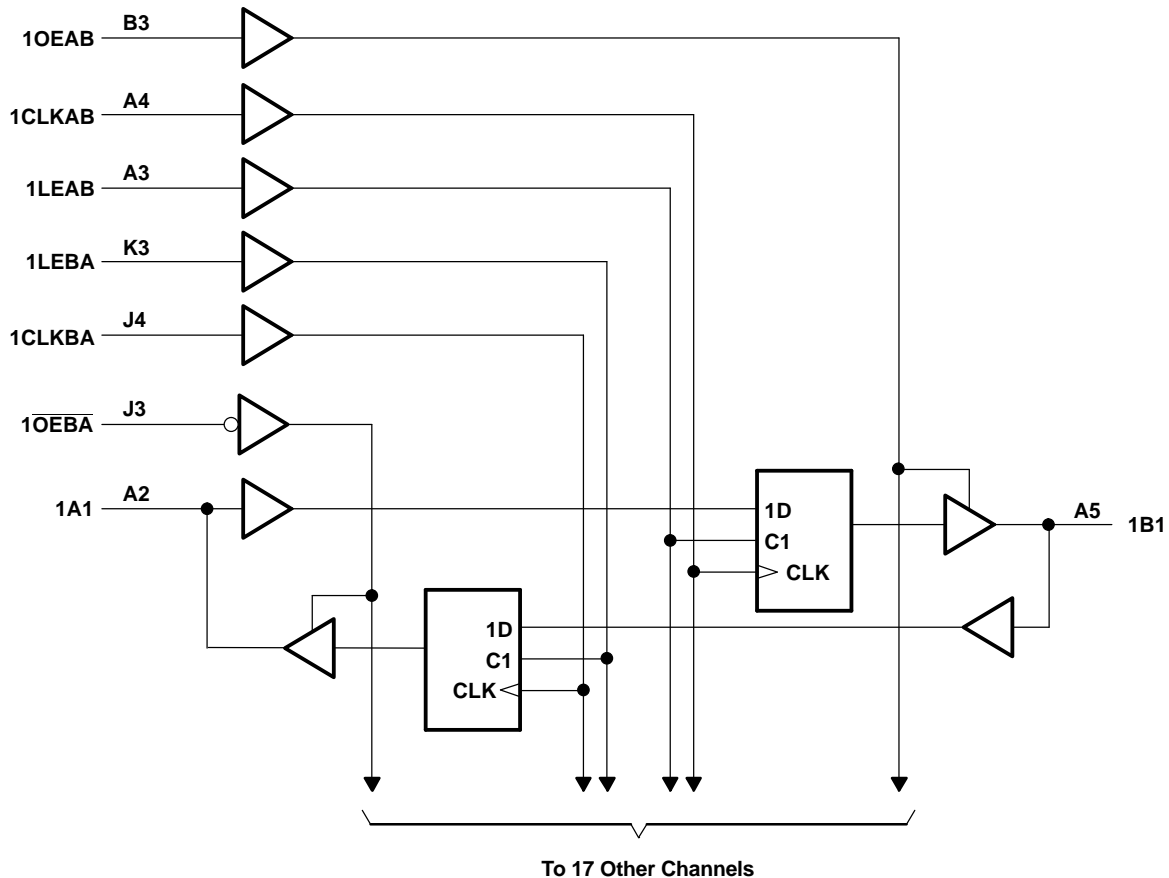

SN74ALVCH32501
36-BIT UNIVERSAL BUS TRANSCEIVER
WITH 3-STATE OUTPUTS

SCES144G—OCTOBER 1998—REVISED OCTOBER 2004

LOGIC DIAGRAM (POSITIVE LOGIC)

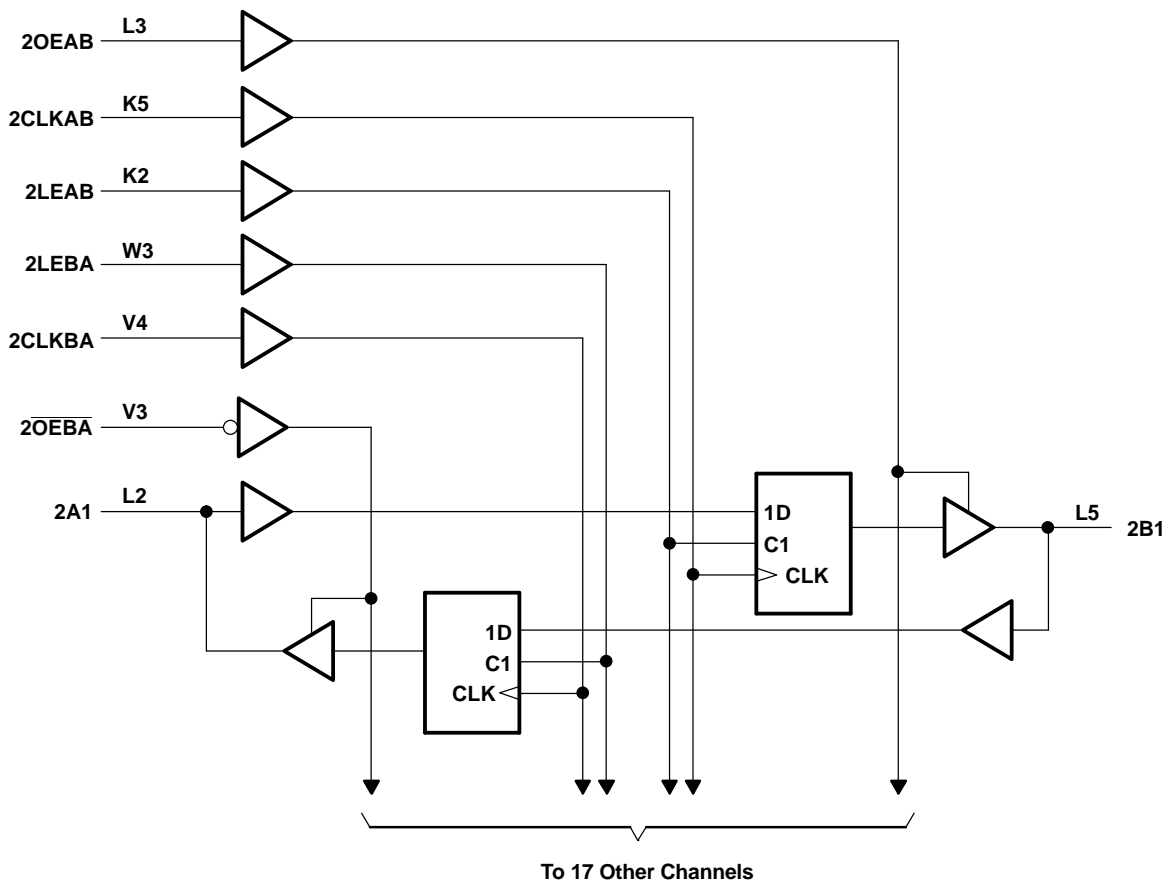

ABSOLUTE MAXIMUM RATINGS⁽¹⁾

over operating free-air temperature range (unless otherwise noted)

| | | MIN | MAX | UNIT |
|---------------|---|---------------------------------|----------------|------|
| V_{CC} | Supply voltage range | -0.5 | 4.6 | V |
| V_I | Input voltage range | Except I/O ports ⁽²⁾ | | V |
| | | | | |
| | | -0.5 | $V_{CC} + 0.5$ | |
| V_O | Output voltage range ⁽²⁾⁽³⁾ | -0.5 | $V_{CC} + 0.5$ | V |
| I_{IK} | Input clamp current | $V_I < 0$ | | mA |
| I_{OK} | Output clamp current | $V_O < 0$ | | |
| I_O | Continuous output current | | | mA |
| | Continuous current through each V_{CC} or GND | | | |
| | | | | ±100 |
| θ_{JA} | Package thermal impedance ⁽⁴⁾ | GKF/ZKF package | | 36 |
| T_{stg} | Storage temperature range | -65 | 150 | °C |

- (1) Stresses beyond those listed under "absolute maximum ratings" may cause permanent damage to the device. These are stress ratings only, and functional operation of the device at these or any other conditions beyond those indicated under "recommended operating conditions" is not implied. Exposure to absolute-maximum-rated conditions for extended periods may affect device reliability.
- (2) The input negative-voltage and output voltage ratings may be exceeded if the input and output current ratings are observed.
- (3) This value is limited to 4.6 V maximum.
- (4) The package thermal impedance is calculated in accordance with JESD 51-7.

RECOMMENDED OPERATING CONDITIONS⁽¹⁾

| | | MIN | MAX | UNIT |
|---------------------|------------------------------------|---|----------------------|------|
| V_{CC} | Supply voltage | 1.65 | 3.6 | V |
| V_{IH} | High-level input voltage | $V_{CC} = 1.65\text{ V to }1.95\text{ V}$ | $0.65 \times V_{CC}$ | V |
| | | $V_{CC} = 2.3\text{ V to }2.7\text{ V}$ | 1.7 | |
| | | $V_{CC} = 2.7\text{ V to }3.6\text{ V}$ | 2 | |
| V_{IL} | Low-level input voltage | $V_{CC} = 1.65\text{ V to }1.95\text{ V}$ | $0.35 \times V_{CC}$ | V |
| | | $V_{CC} = 2.3\text{ V to }2.7\text{ V}$ | 0.7 | |
| | | $V_{CC} = 2.7\text{ V to }3.6\text{ V}$ | 0.8 | |
| V_I | Input voltage | 0 | V_{CC} | V |
| V_O | Output voltage | 0 | V_{CC} | V |
| I_{OH} | High-level output current | $V_{CC} = 1.65\text{ V}$ | -4 | mA |
| | | $V_{CC} = 2.3\text{ V}$ | -12 | |
| | | $V_{CC} = 2.7\text{ V}$ | -12 | |
| | | $V_{CC} = 3\text{ V}$ | -24 | |
| I_{OL} | Low-level output current | $V_{CC} = 1.65\text{ V}$ | 4 | mA |
| | | $V_{CC} = 2.3\text{ V}$ | 12 | |
| | | $V_{CC} = 2.7\text{ V}$ | 12 | |
| | | $V_{CC} = 3\text{ V}$ | 24 | |
| $\Delta t/\Delta v$ | Input transition rise or fall rate | | 10 | ns/V |
| T_A | Operating free-air temperature | -40 | 85 | °C |

- (1) All unused control inputs of the device must be held at V_{CC} or GND to ensure proper device operation. Refer to the TI application report, *Implications of Slow or Floating CMOS Inputs*, literature number SCBA004.

SN74ALVCH32501
36-BIT UNIVERSAL BUS TRANSCEIVER
WITH 3-STATE OUTPUTS

SCES144G–OCTOBER 1998–REVISED OCTOBER 2004

ELECTRICAL CHARACTERISTICS

over recommended operating free-air temperature range (unless otherwise noted)

| PARAMETER | TEST CONDITIONS | V _{CC} | MIN | TYP ⁽¹⁾ | MAX | UNIT |
|--------------------------------|--|---|-----------------------|--------------------|------|------|
| V _{OH} | I _{OH} = -100 μA | 1.65 V to 3.6 V | V _{CC} - 0.2 | | | V |
| | I _{OH} = -4 mA | 1.65 V | 1.2 | | | |
| | I _{OH} = -6 mA | 2.3 V | 2 | | | |
| | I _{OH} = -12 mA | 2.3 V | 1.7 | | | |
| | | 2.7 V | 2.2 | | | |
| | | 3 V | 2.4 | | | |
| I _{OH} = -24 mA | 3 V | 2 | | | | |
| V _{OL} | I _{OL} = 100 μA | 1.65 V to 3.6 V | | | 0.2 | V |
| | I _{OL} = 4 mA | 1.65 V | | | 0.45 | |
| | I _{OL} = 6 mA | 2.3 V | | | 0.4 | |
| | I _{OL} = 12 mA | 2.3 V | | | 0.7 | |
| | | 2.7 V | | | 0.4 | |
| | I _{OL} = 24 mA | 3 V | | | 0.55 | |
| I _I | V _I = V _{CC} or GND | 3.6 V | | | ±5 | μA |
| I _{I(hold)} | V _I = 0.58 V | 1.65 V | 25 | | | μA |
| | V _I = 1.07 V | | -25 | | | |
| | V _I = 0.7 V | 2.3 V | 45 | | | |
| | V _I = 1.7 V | | -45 | | | |
| | V _I = 0.8 V | 3 V | 75 | | | |
| | V _I = 2 V | | -75 | | | |
| | V _I = 0 to 3.6 V ⁽²⁾ | 3.6 V | | | ±500 | |
| I _{OZ} ⁽³⁾ | V _O = V _{CC} or GND | 3.6 V | | | ±10 | μA |
| I _{CC} | V _I = V _{CC} or GND, I _O = 0 | 3.6 V | | | 80 | μA |
| ΔI _{CC} | One input at V _{CC} - 0.6 V, Other inputs at V _{CC} or GND | 3 V to 3.6 V | | | 750 | μA |
| C _i | Control inputs | V _I = V _{CC} or GND | 3.3 V | | 4 | pF |
| C _{io} | A or B ports | V _O = V _{CC} or GND | 3.3 V | | 8 | pF |

(1) All typical values are at V_{CC} = 3.3 V, T_A = 25°C.

(2) This is the bus-hold maximum dynamic current. It is the minimum overdrive current required to switch the input from one state to another.

(3) For I/O ports, the parameter I_{OZ} includes the input leakage current.

TIMING REQUIREMENTS

over recommended operating free-air temperature range (unless otherwise noted) (see Figure 1)

| | | $V_{CC} = 1.8\text{ V}$ | | $V_{CC} = 2.5\text{ V} \pm 0.2\text{ V}$ | | $V_{CC} = 2.7\text{ V}$ | | $V_{CC} = 3.3\text{ V} \pm 0.3\text{ V}$ | | UNIT |
|--------------------|-----------------|-----------------------------|-----------------|--|-----|-------------------------|-----|--|-----|------|
| | | MIN | MAX | MIN | MAX | MIN | MAX | MIN | MAX | |
| f_{clock} | Clock frequency | (1) | | 150 | | 150 | | 150 | | MHz |
| t_w | Pulse duration | LE high | | (1) | 3.3 | 3.3 | 3.3 | 3.3 | | ns |
| | | CLK high or low | | (1) | 3.3 | 3.3 | 3.3 | 3.3 | | |
| t_{su} | Setup time | Data before CLK \uparrow | | (1) | 2.2 | 2.1 | 1.7 | ns | | |
| | | Data before LE \downarrow | CLK high | (1) | 1.9 | 1.6 | 1.5 | | | |
| | | | CLK low | (1) | 1.3 | 1.1 | 1 | | | |
| t_h | Hold time | Data after CLK \uparrow | | (1) | 0.6 | 0.6 | 0.7 | ns | | |
| | | Data after LE \downarrow | CLK high or low | (1) | 1.4 | 1.7 | 1.4 | | | |

(1) This information was not available at the time of publication.

SWITCHING CHARACTERISTICS

over recommended operating free-air temperature range (unless otherwise noted) (see Figure 1)

| PARAMETER | FROM (INPUT) | TO (OUTPUT) | $V_{CC} = 1.8\text{ V}$ | | $V_{CC} = 2.5\text{ V} \pm 0.2\text{ V}$ | | $V_{CC} = 2.7\text{ V}$ | | $V_{CC} = 3.3\text{ V} \pm 0.3\text{ V}$ | | UNIT |
|------------------|--------------------------|-------------|-------------------------|-----|--|-----|-------------------------|-----|--|-----|------|
| | | | MIN | TYP | MIN | MAX | MIN | MAX | MIN | MAX | |
| f_{max} | | | (1) | | 150 | | 150 | | 150 | | MHz |
| t_{pd} | A or B | B or A | (1) | | 1 | 4.8 | 4.5 | 1 | 3.9 | ns | |
| | LE | A or B | (1) | 1.1 | 5.7 | 5.3 | 1.3 | 4.6 | | | |
| | CLK | | (1) | 1.2 | 6.1 | 5.6 | 1.4 | 4.9 | | | |
| t_{en} | OEAB | B | (1) | 1 | 5.8 | 5.3 | 1 | 4.6 | ns | | |
| t_{dis} | OEAB | B | (1) | 1.5 | 6.2 | 5.7 | 1.4 | 5 | ns | | |
| t_{en} | $\overline{\text{OEBA}}$ | A | (1) | 1.3 | 6.3 | 6 | 1.1 | 5 | ns | | |
| t_{dis} | $\overline{\text{OEBA}}$ | A | (1) | 1.3 | 5.3 | 4.6 | 1.3 | 4.2 | ns | | |

(1) This information was not available at the time of publication.

OPERATING CHARACTERISTICS

$T_A = 25^\circ\text{C}$

| PARAMETER | | TEST CONDITIONS | $V_{CC} = 1.8\text{ V}$ | $V_{CC} = 2.5\text{ V}$ | $V_{CC} = 3.3\text{ V}$ | UNIT |
|-----------------|-------------------------------|------------------------------|-------------------------|-------------------------|-------------------------|------|
| | | | TYP | TYP | TYP | |
| C_{pd} | Power dissipation capacitance | $C_L = 0, f = 10\text{ MHz}$ | (1) | 44 | 54 | pF |
| | Outputs enabled | | (1) | 6 | 6 | |
| | Outputs disabled | | | | | |

(1) This information was not available at the time of publication.

PARAMETER MEASUREMENT INFORMATION

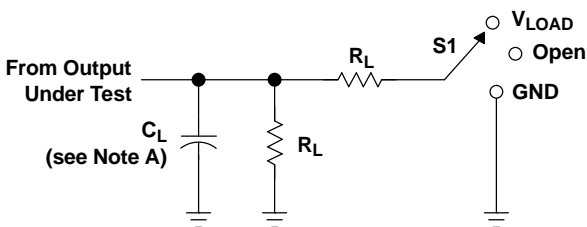

| TEST | S1 |
|--|---------------------------|
| t_{pd} t_{PLZ}/t_{PZL} t_{PHZ}/t_{PZH} | Open V_{LOAD} GND |

LOAD CIRCUIT

| V_{CC} | INPUT | | V_M | V_{LOAD} | C_L | R_L | V_{Δ} |
|----------------------------------|----------|----------------------|------------|-------------------|-------|--------------|--------------|
| | V_I | t_r/t_f | | | | | |
| $1.8\text{ V} \pm 0.15\text{ V}$ | V_{CC} | $\leq 2\text{ ns}$ | $V_{CC}/2$ | $2 \times V_{CC}$ | 30 pF | 1 k Ω | 0.15 V |
| $2.5\text{ V} \pm 0.2\text{ V}$ | V_{CC} | $\leq 2\text{ ns}$ | $V_{CC}/2$ | $2 \times V_{CC}$ | 30 pF | 500 Ω | 0.15 V |
| 2.7 V | 2.7 V | $\leq 2.5\text{ ns}$ | 1.5 V | 6 V | 50 pF | 500 Ω | 0.3 V |
| $3.3\text{ V} \pm 0.3\text{ V}$ | 2.7 V | $\leq 2.5\text{ ns}$ | 1.5 V | 6 V | 50 pF | 500 Ω | 0.3 V |

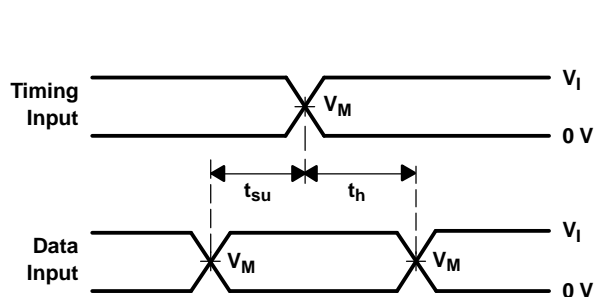

VOLTAGE WAVEFORMS
SETUP AND HOLD TIMES

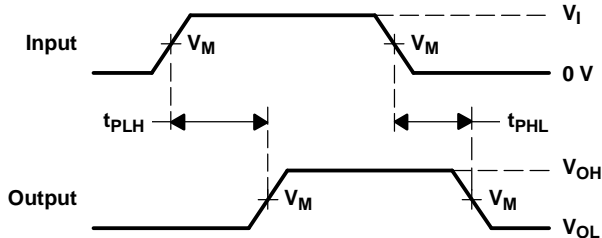

VOLTAGE WAVEFORMS
PROPAGATION DELAY TIMES

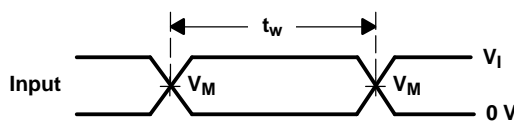

VOLTAGE WAVEFORMS
PULSE DURATION

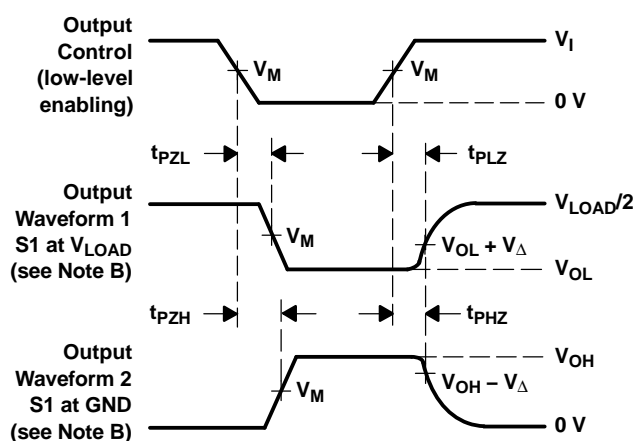

VOLTAGE WAVEFORMS
ENABLE AND DISABLE TIMES

- NOTES: A. C_L includes probe and jig capacitance.
B. Waveform 1 is for an output with internal conditions such that the output is low, except when disabled by the output control. Waveform 2 is for an output with internal conditions such that the output is high, except when disabled by the output control.
C. All input pulses are supplied by generators having the following characteristics: $PRR \leq 10\text{ MHz}$, $Z_O = 50\ \Omega$.
D. The outputs are measured one at a time, with one transition per measurement.
E. t_{PLZ} and t_{PHZ} are the same as t_{dis} .
F. t_{PZL} and t_{PZH} are the same as t_{en} .
G. t_{PLH} and t_{PHL} are the same as t_{pd} .
H. All parameters and waveforms are not applicable to all devices.

Figure 1. Load Circuit and Voltage Waveforms

PACKAGING INFORMATION

| Orderable Device | Status ⁽¹⁾ | Package Type | Package Drawing | Pins | Package Qty | Eco Plan ⁽²⁾ | Lead/Ball Finish | MSL Peak Temp ⁽³⁾ |
|--------------------|-----------------------|--------------|-----------------|------|-------------|-------------------------|------------------|------------------------------|
| 74ALVCH32501ZKFR | ACTIVE | LFBGA | ZKF | 114 | 1000 | Green (RoHS & no Sb/Br) | SNAGCU | Level-3-250C-168 HR |
| SN74ALVCH32501GKFR | OBSOLETE | LFBGA | GKF | 114 | | None | Call TI | Call TI |
| SN74ALVCH32501KR | ACTIVE | LFBGA | GKF | 114 | 1000 | None | SNPB | Level-3-220C-168 HR |

⁽¹⁾ The marketing status values are defined as follows:

ACTIVE: Product device recommended for new designs.

LIFEBUY: TI has announced that the device will be discontinued, and a lifetime-buy period is in effect.

NRND: Not recommended for new designs. Device is in production to support existing customers, but TI does not recommend using this part in a new design.

PREVIEW: Device has been announced but is not in production. Samples may or may not be available.

OBSOLETE: TI has discontinued the production of the device.

⁽²⁾ Eco Plan - May not be currently available - please check <http://www.ti.com/productcontent> for the latest availability information and additional product content details.

None: Not yet available Lead (Pb-Free).

Pb-Free (RoHS): TI's terms "Lead-Free" or "Pb-Free" mean semiconductor products that are compatible with the current RoHS requirements for all 6 substances, including the requirement that lead not exceed 0.1% by weight in homogeneous materials. Where designed to be soldered at high temperatures, TI Pb-Free products are suitable for use in specified lead-free processes.

Green (RoHS & no Sb/Br): TI defines "Green" to mean "Pb-Free" and in addition, uses package materials that do not contain halogens, including bromine (Br) or antimony (Sb) above 0.1% of total product weight.

⁽³⁾ MSL, Peak Temp. -- The Moisture Sensitivity Level rating according to the JEDEC industry standard classifications, and peak solder temperature.

Important Information and Disclaimer: The information provided on this page represents TI's knowledge and belief as of the date that it is provided. TI bases its knowledge and belief on information provided by third parties, and makes no representation or warranty as to the accuracy of such information. Efforts are underway to better integrate information from third parties. TI has taken and continues to take reasonable steps to provide representative and accurate information but may not have conducted destructive testing or chemical analysis on incoming materials and chemicals. TI and TI suppliers consider certain information to be proprietary, and thus CAS numbers and other limited information may not be available for release.

In no event shall TI's liability arising out of such information exceed the total purchase price of the TI part(s) at issue in this document sold by TI to Customer on an annual basis.

GKF (R-PBGA-N114)

PLASTIC BALL GRID ARRAY

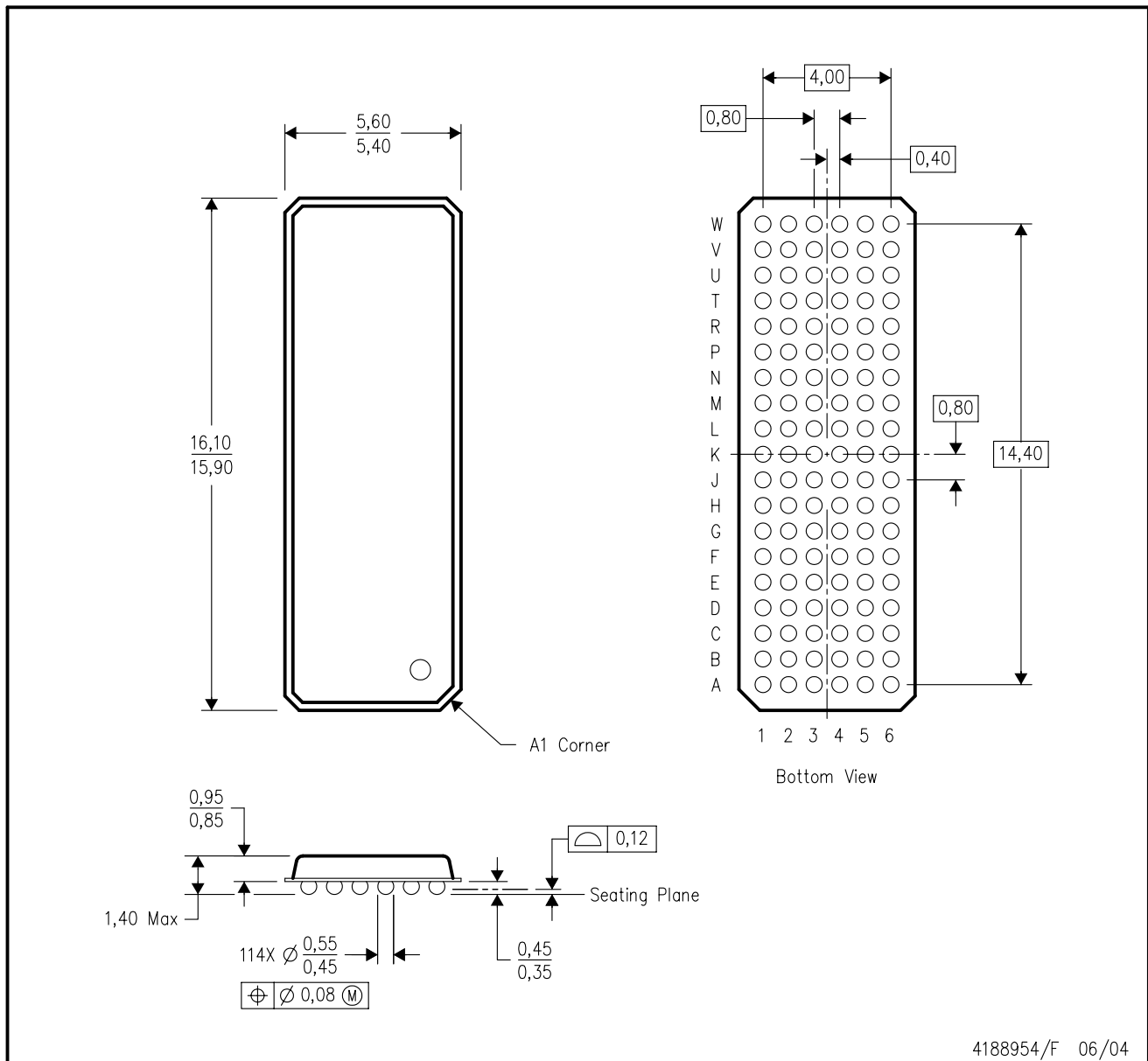

4188954/F 06/04

- NOTES:
- A. All linear dimensions are in millimeters.
 - B. This drawing is subject to change without notice.
 - C. Falls within JEDEC MO-205 variation DC.
 - D. This package is tin-lead (SnPb). Refer to the 114 ZKF package (drawing 4204494) for lead-free.

ZKF (R-PBGA-N114)

PLASTIC BALL GRID ARRAY

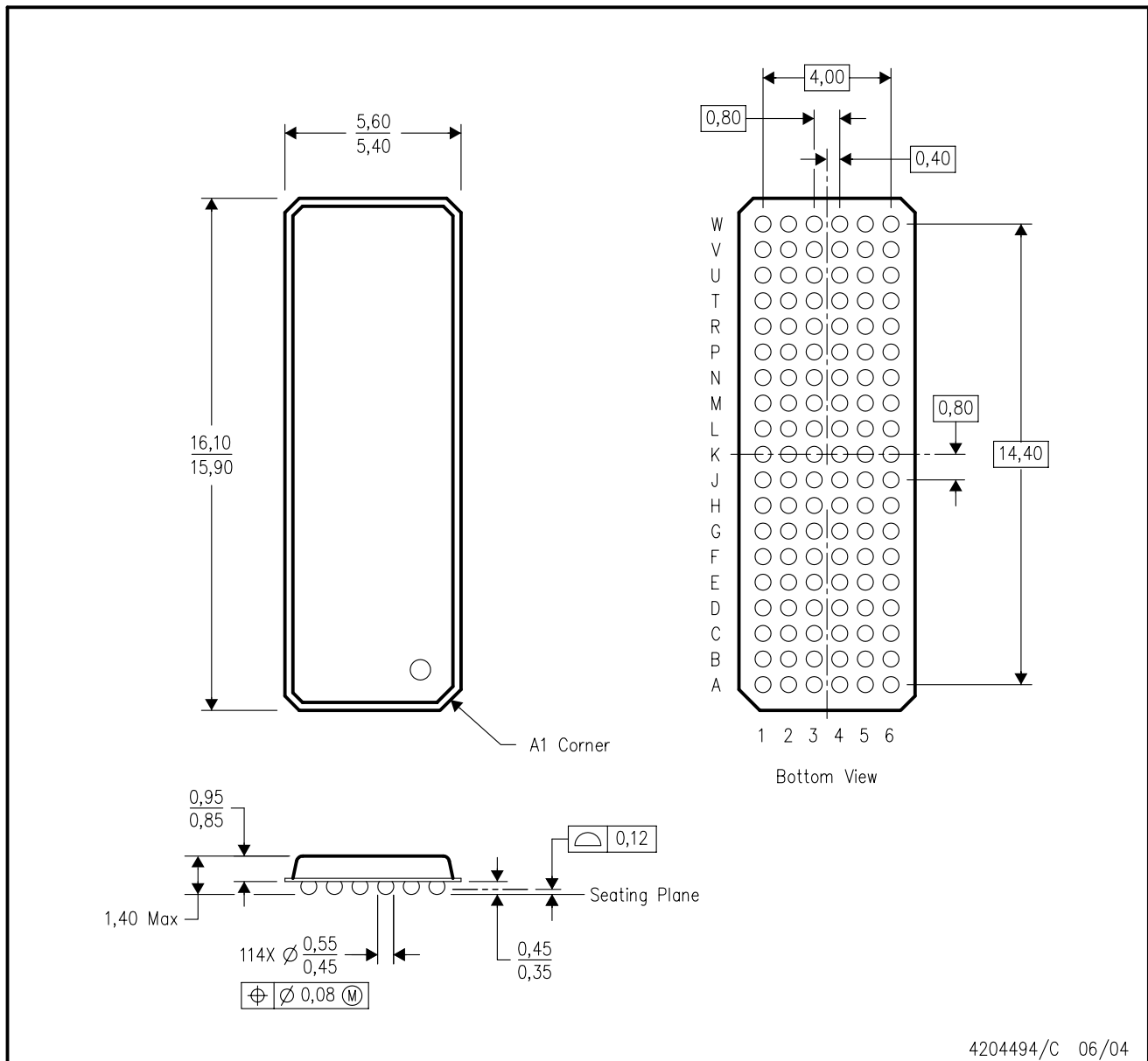

- NOTES:
- A. All linear dimensions are in millimeters.
 - B. This drawing is subject to change without notice.
 - C. Falls within JEDEC MO-205 variation DC.
 - D. This package is lead-free. Refer to the 114 GKF package (drawing 4188954) for tin-lead (SnPb).

IMPORTANT NOTICE

Texas Instruments Incorporated and its subsidiaries (TI) reserve the right to make corrections, modifications, enhancements, improvements, and other changes to its products and services at any time and to discontinue any product or service without notice. Customers should obtain the latest relevant information before placing orders and should verify that such information is current and complete. All products are sold subject to TI's terms and conditions of sale supplied at the time of order acknowledgment.

TI warrants performance of its hardware products to the specifications applicable at the time of sale in accordance with TI's standard warranty. Testing and other quality control techniques are used to the extent TI deems necessary to support this warranty. Except where mandated by government requirements, testing of all parameters of each product is not necessarily performed.

TI assumes no liability for applications assistance or customer product design. Customers are responsible for their products and applications using TI components. To minimize the risks associated with customer products and applications, customers should provide adequate design and operating safeguards.

TI does not warrant or represent that any license, either express or implied, is granted under any TI patent right, copyright, mask work right, or other TI intellectual property right relating to any combination, machine, or process in which TI products or services are used. Information published by TI regarding third-party products or services does not constitute a license from TI to use such products or services or a warranty or endorsement thereof. Use of such information may require a license from a third party under the patents or other intellectual property of the third party, or a license from TI under the patents or other intellectual property of TI.

Reproduction of information in TI data books or data sheets is permissible only if reproduction is without alteration and is accompanied by all associated warranties, conditions, limitations, and notices. Reproduction of this information with alteration is an unfair and deceptive business practice. TI is not responsible or liable for such altered documentation.

Resale of TI products or services with statements different from or beyond the parameters stated by TI for that product or service voids all express and any implied warranties for the associated TI product or service and is an unfair and deceptive business practice. TI is not responsible or liable for any such statements.

Following are URLs where you can obtain information on other Texas Instruments products and application solutions:

| Products | | Applications | |
|------------------|--|---------------------|--|
| Amplifiers | amplifier.ti.com | Audio | www.ti.com/audio |
| Data Converters | dataconverter.ti.com | Automotive | www.ti.com/automotive |
| DSP | dsp.ti.com | Broadband | www.ti.com/broadband |
| Interface | interface.ti.com | Digital Control | www.ti.com/digitalcontrol |
| Logic | logic.ti.com | Military | www.ti.com/military |
| Power Mgmt | power.ti.com | Optical Networking | www.ti.com/opticalnetwork |
| Microcontrollers | microcontroller.ti.com | Security | www.ti.com/security |
| | | Telephony | www.ti.com/telephony |
| | | Video & Imaging | www.ti.com/video |
| | | Wireless | www.ti.com/wireless |

Mailing Address: Texas Instruments
Post Office Box 655303 Dallas, Texas 75265