



SCCS028B - December 1987 - Revised September 2001

16-Bit Buffers/Line Drivers

Features

- I_{off} supports partial-power-down mode operation
- Edge-rate control circuitry for significantly improved noise characteristics
- Typical output skew < 250 ps
- ESD > 2000V
- TSSOP (19.6-mil pitch) and SSOP (25-mil pitch) packages
- Industrial temperature range of -40°C to $+85^{\circ}\text{C}$
- $V_{CC} = 5\text{V} \pm 10\%$

CY74FCT16244T Features:

- 64 mA sink current, 32 mA source current
- Typical V_{OLP} (ground bounce) < 1.0V at $V_{CC} = 5\text{V}$, $T_A = 25^{\circ}\text{C}$

CY74FCT162244T Features:

- Balanced output drivers: 24 mA
- Reduced system switching noise
- Typical V_{OLP} (ground bounce) < 0.6V at $V_{CC} = 5\text{V}$, $T_A = 25^{\circ}\text{C}$

CY74FCT162H244T Features:

- Bus hold on data inputs
- Eliminates the need for external pull-up or pull-down resistors

Functional Description

These 16-bit buffers/line drivers are designed for use in memory driver, clock driver, or other bus interface applications, where high-speed and low power are required. With flow-through pinout and small shrink packaging board layout is simplified. The three-state controls are designed to allow 4-bit, 8-bit or combined 16-bit operation.

This device is fully specified for partial-power-down applications using I_{off} . The I_{off} circuitry disables the outputs, preventing damaging current backflow through the device when it is powered down.

The CY74FCT16244T is ideally suited for driving high-capacitance loads and low-impedance backplanes.

The CY74FCT162244T has 24-mA balanced output drivers with current limiting resistors in the outputs. This reduces the need for external terminating resistors and provides for minimal undershoot and reduced ground bounce. The CY74FCT162244T is ideal for driving transmission lines.

The CY74FCT162H244T is a 24-mA balanced output part that has "bus hold" on the data inputs. The device retains the input's last state whenever the input goes to high impedance. This eliminates the need for pull-up/down resistors and prevents floating inputs.

Logic Block Diagrams CY74FCT16244T, CY74FCT162244T, CY74FCT162H244T

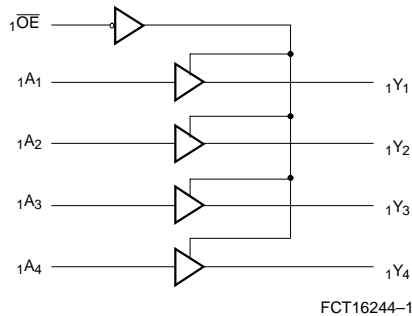

FCT16244-1

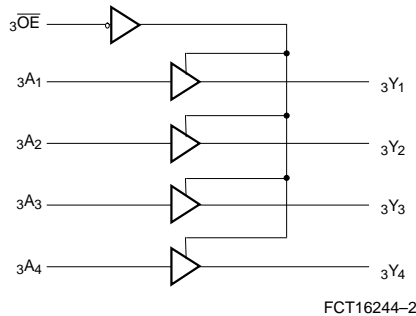

FCT16244-2

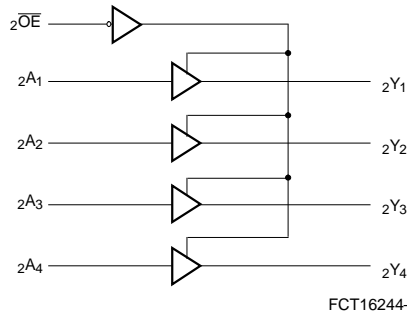

FCT16244-3

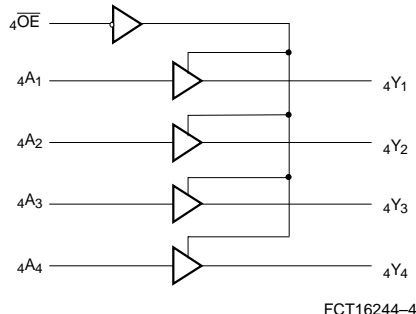

FCT16244-4

Pin Configuration

SSOP/TSSOP Top View

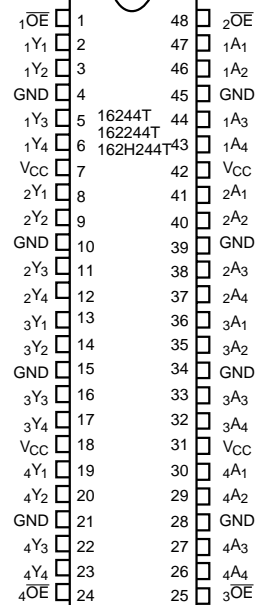

FCT16244-5

Pin Description

Name	Description
\overline{OE}	Three-State Output Enable Inputs (Active LOW)
A	Data Inputs ^[1]
Y	Three-State Outputs

Function Table^[2]

Inputs		Outputs
\overline{OE}	A	Y
L	L	L
L	H	H
H	X	Z

Maximum Ratings^[3,4]

(Above which the useful life may be impaired. For user guidelines, not tested.)

Storage Temperature.....	-55°C to +125°C
Ambient Temperature with Power Applied.....	-55°C to +125°C
DC Input Voltage	-0.5V to +7.0V
DC Output Voltage.....	-0.5V to +7.0V
DC Output Current (Maximum Sink Current/Pin)	-60 to +120 mA
Power Dissipation	1.0W
Static Discharge Voltage.....	>2001V (per MIL-STD-883, Method 3015)

Ordering Range

Range	Ambient Temperature	V _{CC}
Industrial	- 40°C to +85°C	5V ± 10%

Notes:

- On CY74FCT162H244T these pins have "bus hold."
- H = HIGH Voltage Level. L = LOW Voltage Level. X = Don't Care. Z = High Importance.
- Operation beyond the limits set forth may impair the useful life of the device. Unless otherwise noted, these limits are over the operating free-air temperature range.
- Unused inputs must always be connected to an appropriate logic voltage level, preferably either V_{CC} or ground.

Electrical Characteristics Over the Operating Range

Parameter	Description	Test Conditions	Min.	Typ. ^[5]	Max.	Unit
V _{IH}	Input HIGH Voltage		2.0			V
V _{IL}	Input LOW Voltage				0.8	V
V _H	Input Hysteresis ^[6]			100		mV
V _{IK}	Input Clamp Diode Voltage	V _{CC} =Min., I _{IN} =-18 mA		-0.7	-1.2	V
I _{IH}	Input HIGH Current	Standard	V _{CC} =Max., V _I =V _{CC}		±1	μA
		Bus Hold			±100	
I _{IL}	Input LOW Current	Standard	V _{CC} =Max., V _I =GND		±1	μA
		Bus Hold			±100	
I _{BBH} I _{BBL}	Bus Hold Sustain Current on Bus Hold Input ^[7]	V _{CC} =Min.	V _I =2.0V	-50		μA
			V _I =0.8V	+50		
I _{BHHO} I _{BHLO}	Bus Hold Overdrive Current on Bus Hold Input ^[7]	V _{CC} =Max., V _I =1.5V			TBD	mA
I _{OZH}	High Impedance Output Current (Three-State Output pins)	V _{CC} =Max., V _{OUT} =2.7V			±1	μA
I _{OZL}	High Impedance Output Current (Three-State Output pins)	V _{CC} =Max., V _{OUT} =0.5V			±1	μA
I _{OS}	Short Circuit Current ^[8]	V _{CC} =Max., V _{OUT} =GND	-80	-140	-200	mA
I _O	Output Drive Current ^[8]	V _{CC} =Max., V _{OUT} =2.5V	-50		-180	mA
I _{OFF}	Power-Off Disable	V _{CC} =0V, V _{OUT} ≤4.5V ^[9]			±1	μA

Output Drive Characteristics for CY74FCT16244T

Parameter	Description	Test Conditions	Min.	Typ. ^[5]	Max.	Unit
V _{OH}	Output HIGH Voltage	V _{CC} =Min., I _{OH} =-3 mA	2.5	3.5		V
		V _{CC} =Min., I _{OH} =-15 mA	2.4	3.5		V
		V _{CC} =Min., I _{OH} =-32 mA	2.0	3.0		V
V _{OL}	Output LOW Voltage	V _{CC} =Min., I _{OL} =64 mA		0.2	0.55	V

Output Drive Characteristics for CY74FCT162244T, CY74FCT162H244T

Parameter	Description	Test Conditions	Min.	Typ. ^[5]	Max.	Unit
I _{ODL}	Output LOW Current ^[8]	V _{CC} =5V, V _{IN} =V _{IH} or V _{IL} , V _{OUT} =1.5V	60	115	150	mA
I _{ODH}	Output HIGH Current ^[8]	V _{CC} =5V, V _{IN} =V _{IH} or V _{IL} , V _{OUT} =1.5V	-60	-115	-150	mA
V _{OH}	Output HIGH Voltage	V _{CC} =Min., I _{OH} =-24 mA	2.4	3.3		V
V _{OL}	Output LOW Voltage	V _{CC} =Min., I _{OL} =24 mA		0.3	0.55	V

Notes:

5. Typical values are at V_{CC}=5.0V, T_A = +25°C ambient.
6. This parameter is specified but not tested.
7. Pins with bus hold are described in Pin Description.
8. Not more than one output should be shorted at a time. Duration of short should not exceed one second. The use of high-speed test apparatus and/or sample and hold techniques are preferable in order to minimize internal chip heating and more accurately reflect operational values. Otherwise prolonged shorting of a high output may raise the chip temperature well above normal and thereby cause invalid readings in other parametric tests. In any sequence of parameter tests, I_{OS} tests should be performed last.
9. Tested at +25°C.

Capacitance^[6] ($T_A = +25^\circ\text{C}$, $f = 1.0\text{ MHz}$)

Parameter	Description	Test Conditions	Typ. ^[5]	Max.	Unit
C_{IN}	Input Capacitance	$V_{IN} = 0V$	4.5	6.0	pF
C_{OUT}	Output Capacitance	$V_{OUT} = 0V$	5.5	8.0	pF

Power Supply Characteristics

Parameter	Description	Test Conditions	Typ. ^[5]	Max.	Unit	
I_{CC}	Quiescent Power Supply Current	$V_{CC} = \text{Max.}$ $V_{IN} \leq 0.2V$, $V_{IN} \leq V_{CC} - 0.2V$	5	500	μA	
ΔI_{CC}	Quiescent Power Supply Current (TTL inputs HIGH)	$V_{CC} = \text{Max.}$ $V_{IN} = 3.4V^{[10]}$	0.5	1.5	mA	
I_{CCD}	Dynamic Power Supply Current ^[11]	$V_{CC} = \text{Max.}$, One Input Toggling, 50% Duty Cycle, Outputs Open, $OE = \text{GND}$	60	100	$\mu\text{A}/\text{MHz}$	
I_C	Total Power Supply Current ^[12]	$V_{CC} = \text{Max.}$, $f_1 = 10\text{ MHz}$, 50% Duty Cycle, Outputs Open, One Bit Toggling, $OE = \text{GND}$	$V_{IN} = V_{CC}$ or $V_{IN} = \text{GND}$	0.6	1.5	mA
			$V_{IN} = 3.4V$ or $V_{IN} = \text{GND}$	0.9	2.3	mA
		$V_{CC} = \text{Max.}$, $f_1 = 2.5\text{ MHz}$, 50% Duty Cycle, Outputs Open, Sixteen Bits Toggling, $OE = \text{GND}$	$V_{IN} = V_{CC}$ or $V_{IN} = \text{GND}$	2.4	4.5 ^[13]	mA
			$V_{IN} = 3.4V$ or $V_{IN} = \text{GND}$	6.4	16.5 ^[13]	mA

Notes:

10. Per TTL driven input ($V_{IN} = 3.4V$); all other inputs at V_{CC} or GND.
11. This parameter is not directly testable, but is derived for use in Total Power Supply calculations.
12. $I_C = I_{CC} + \Delta I_{CC} D_H N_T + I_{CCD} (f_0/2 + f_1 N_1)$
 I_C = Total Power Supply Current
 I_{CC} = Quiescent Current with CMOS input levels
 ΔI_{CC} = Power Supply Current for a TTL HIGH input ($V_{IN} = 3.4V$)
 D_H = Duty Cycle for TTL inputs HIGH
 N_T = Number of TTL inputs at D_H
 I_{CCD} = Dynamic Current caused by an input transition pair (HLH or LHL)
 f_0 = Clock frequency for registered devices, otherwise zero
 f_1 = Input signal frequency
 N_1 = Number of inputs changing at f_1
 All currents are in milliamps and all frequencies are in megahertz.
13. Values for these conditions are examples of the I_{CC} formula. These limits are specified but not tested.

Switching Characteristics Over the Operating Range^[14]

Parameter	Description	CY74FCT16244T CY74FCT162244T		CY74FCT16244AT CY74FCT162244AT CY74FCT162H244AT		Unit	Fig. No. ^[15]
		Min.	Max.	Min.	Max.		
t _{PLH} t _{PHL}	Propagation Delay Data to Output	1.5	6.5	1.5	4.8	ns	1, 3
t _{PZH} t _{PZL}	Output Enable Time	1.5	8.0	1.5	6.2	ns	1, 7, 8
t _{PHZ} t _{PLZ}	Output Disable Time	1.5	7.0	1.5	5.6	ns	1, 7, 8
t _{SK(O)}	Output Skew ^[16]		0.5		0.5	ns	—

Switching Characteristics Over the Operating Range^[14] (continued)

Parameter	Description	CY74FCT16244CT CY74FCT162244CT CY74FCT162H244CT		Unit	Fig. No. ^[15]
		Min.	Max.		
t _{PLH} t _{PHL}	Propagation Delay Data to Output	1.5	4.1	ns	1, 3
t _{PZH} t _{PZL}	Output Enable Time	1.5	5.8	ns	1, 7, 8
t _{PHZ} t _{PLZ}	Output Disable Time	1.5	5.2	ns	1, 7, 8
t _{SK(O)}	Output Skew ^[16]		0.5	ns	—

Notes:

14. Minimum limits are specified but not tested on Propagation Delays.
 15. See "Parameter Measurement Information" in the General Information section.
 16. Skew between any two outputs of the same package switching in the same direction. This parameter is ensured by design.

Ordering Information CY74FCT16244

Speed (ns)	Ordering Code	Package Name	Package Type	Operating Range
4.1	CY74FCT16244CTPACT	Z48	48-Lead (240-Mil) TSSOP	Industrial
	CY74FCT16244CTPVC/PVCT	O48	48-Lead (300-Mil) SSOP	
4.8	CY74FCT16244ATPACT	Z48	48-Lead (240-Mil) TSSOP	Industrial
	CY74FCT16244ATPVC/PVCT	O48	48-Lead (300-Mil) SSOP	
6.5	CY74FCT16244TPACT	Z48	48-Lead (240-Mil) TSSOP	Industrial
	CY74FCT16244TPVC/PVCT	O48	48-Lead (300-Mil) SSOP	

Ordering Information CY74FCT162244

Speed (ns)	Ordering Code	Package Name	Package Type	Operating Range
4.1	74FCT162244CTPACT	Z48	48-Lead (240-Mil) TSSOP	Industrial
	CY74FCT162244CTPVC	O48	48-Lead (300-Mil) SSOP	
	74FCT162244CTPVCT	O48	48-Lead (300-Mil) SSOP	
4.8	74FCT162244ATPACT	Z48	48-Lead (240-Mil) TSSOP	Industrial
	CY74FCT162244ATPVC	O48	48-Lead (300-Mil) SSOP	
	74FCT162244ATPVCT	O48	48-Lead (300-Mil) SSOP	
6.5	CY74FCT162244TPACT	Z48	48-Lead (240-Mil) TSSOP	Industrial
	CY74FCT162244TPVC/PVCT	O48	48-Lead (300-Mil) SSOP	

Ordering Information CY74FCT162H244

Speed (ns)	Ordering Code	Package Name	Package Type	Operating Range
4.1	74FCT162H244CTPVC/PVCT	O48	48-Lead (300-Mil) SSOP	Industrial
4.8	74FCT162H244ATPACT	Z48	48-Lead (240-Mil) TSSOP	Industrial

Document #: 38-00396-C

Package Diagrams

48-Lead Shrunk Small Outline Package O48

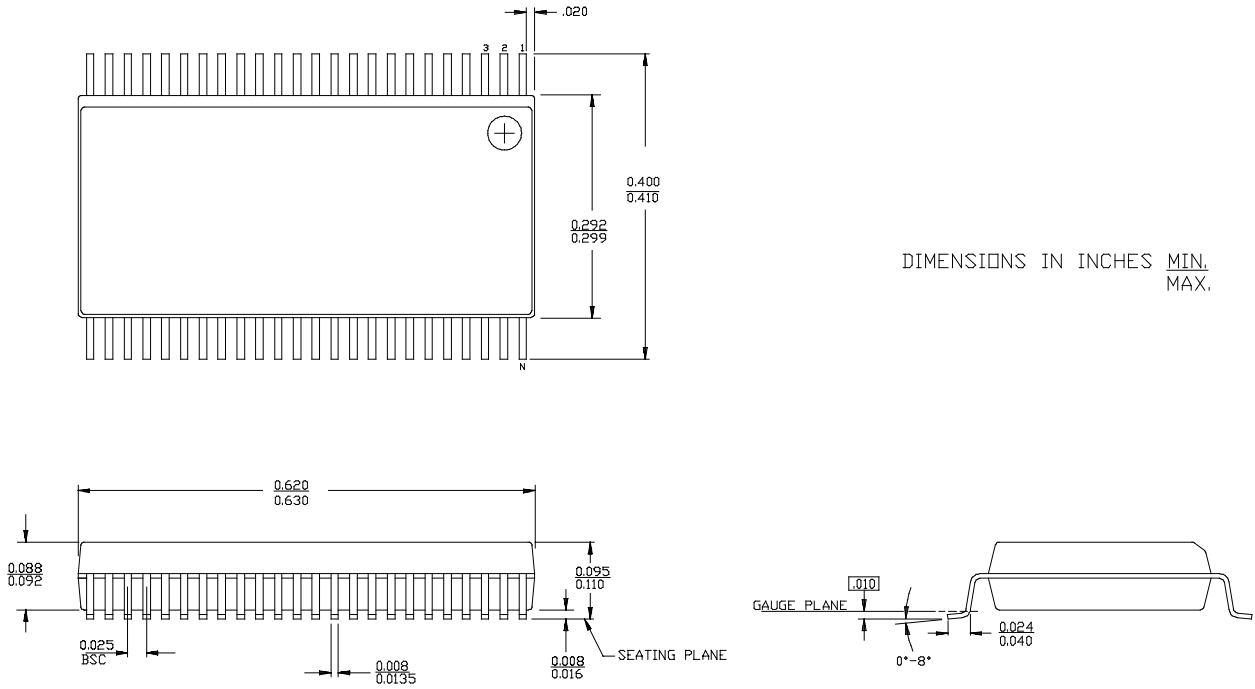

48-Lead Thin Shrunk Small Outline Package Z48

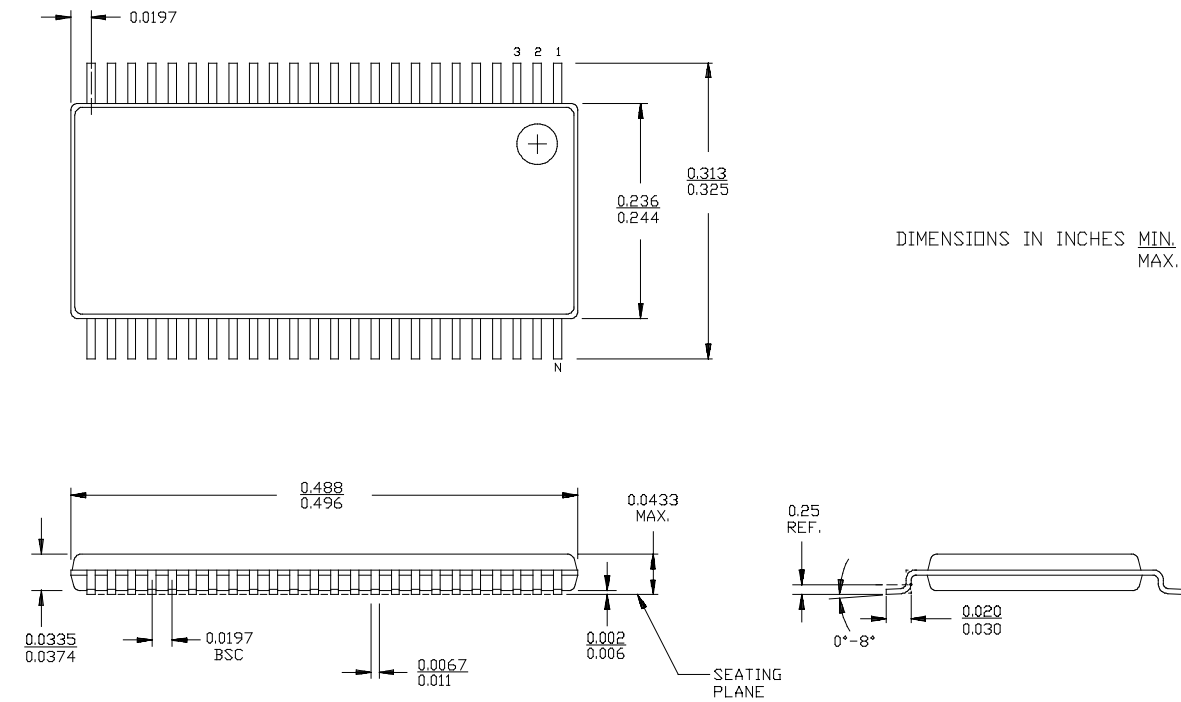

PACKAGING INFORMATION

Orderable Device	Status ⁽¹⁾	Package Type	Package Drawing	Pins	Package Qty	Eco Plan ⁽²⁾	Lead/Ball Finish	MSL Peak Temp ⁽³⁾
74FCT162244ATPACT	ACTIVE	TSSOP	DGG	48	2000	Pb-Free (RoHS)	CU NIPDAU	Level-1-250C-UNLIM
74FCT162244ATPVCT	ACTIVE	SSOP	DL	48	1000	None	CU NIPDAU	Level-1-235C-UNLIM
74FCT162244CTPACT	ACTIVE	TSSOP	DGG	48	2000	Pb-Free (RoHS)	CU NIPDAU	Level-1-250C-UNLIM
74FCT162244CTPVCT	ACTIVE	SSOP	DL	48	1000	None	CU NIPDAU	Level-1-235C-UNLIM
74FCT162244ETPACT	OBSOLETE	TSSOP	DGG	48		None	Call TI	Call TI
74FCT162244ETPVCT	OBSOLETE	SSOP	DL	48		None	Call TI	Call TI
74FCT162H244ATPACT	ACTIVE	TSSOP	DGG	48	2000	Pb-Free (RoHS)	CU NIPDAU	Level-1-250C-UNLIM
74FCT162H244CTPVC	ACTIVE	SSOP	DL	48	25	None	CU NIPDAU	Level-1-235C-UNLIM
74FCT162H244CTPVCT	ACTIVE	SSOP	DL	48	1000	None	CU NIPDAU	Level-1-235C-UNLIM
74FCT162H244ETPAC	OBSOLETE	TSSOP	DGG	48		None	Call TI	Call TI
74FCT162H244ETPACT	OBSOLETE	TSSOP	DGG	48		None	Call TI	Call TI
74FCT162H244ETPVC	OBSOLETE	SSOP	DL	48		None	Call TI	Call TI
74FCT162H244ETPVCT	OBSOLETE	SSOP	DL	48		None	Call TI	Call TI
CY74FCT162244ATPVC	ACTIVE	SSOP	DL	48	25	None	CU NIPDAU	Level-1-235C-UNLIM
CY74FCT162244CTPVC	ACTIVE	SSOP	DL	48	25	None	CU NIPDAU	Level-1-235C-UNLIM
CY74FCT162244ETPAC	OBSOLETE	TSSOP	DGG	48		None	Call TI	Call TI
CY74FCT162244ETPVC	OBSOLETE	SSOP	DL	48		None	Call TI	Call TI
CY74FCT162244TPACT	ACTIVE	TSSOP	DGG	48	2000	Pb-Free (RoHS)	CU NIPDAU	Level-1-250C-UNLIM
CY74FCT162244TPVC	ACTIVE	SSOP	DL	48	25	None	CU NIPDAU	Level-1-235C-UNLIM
CY74FCT162244TPVCT	ACTIVE	SSOP	DL	48	1000	None	CU NIPDAU	Level-1-235C-UNLIM
CY74FCT16244ATPACT	ACTIVE	TSSOP	DGG	48	2000	Pb-Free (RoHS)	CU NIPDAU	Level-1-250C-UNLIM
CY74FCT16244ATPVC	ACTIVE	SSOP	DL	48	25	None	CU NIPDAU	Level-1-235C-UNLIM
CY74FCT16244ATPVCT	ACTIVE	SSOP	DL	48	1000	None	CU NIPDAU	Level-1-235C-UNLIM
CY74FCT16244CTPACT	ACTIVE	TSSOP	DGG	48	2000	Pb-Free (RoHS)	CU NIPDAU	Level-1-250C-UNLIM
CY74FCT16244CTPVC	ACTIVE	SSOP	DL	48	25	None	CU NIPDAU	Level-1-235C-UNLIM
CY74FCT16244CTPVCT	ACTIVE	SSOP	DL	48	1000	None	CU NIPDAU	Level-1-235C-UNLIM
CY74FCT16244ETPAC	OBSOLETE	TSSOP	DGG	48		None	Call TI	Call TI
CY74FCT16244ETPACT	OBSOLETE	TSSOP	DGG	48		None	Call TI	Call TI
CY74FCT16244ETPVC	OBSOLETE	SSOP	DL	48		None	Call TI	Call TI
CY74FCT16244ETPVCT	OBSOLETE	SSOP	DL	48		None	Call TI	Call TI
CY74FCT16244TPACT	ACTIVE	TSSOP	DGG	48	2000	Pb-Free (RoHS)	CU NIPDAU	Level-1-250C-UNLIM
CY74FCT16244TPVC	ACTIVE	SSOP	DL	48	25	None	CU NIPDAU	Level-1-235C-UNLIM
CY74FCT16244TPVCT	ACTIVE	SSOP	DL	48	1000	None	CU NIPDAU	Level-1-235C-UNLIM

⁽¹⁾ The marketing status values are defined as follows:

ACTIVE: Product device recommended for new designs.

LIFEBUY: TI has announced that the device will be discontinued, and a lifetime-buy period is in effect.

NRND: Not recommended for new designs. Device is in production to support existing customers, but TI does not recommend using this part in a new design.

PREVIEW: Device has been announced but is not in production. Samples may or may not be available.

OBSOLETE: TI has discontinued the production of the device.

(2) Eco Plan - May not be currently available - please check <http://www.ti.com/productcontent> for the latest availability information and additional product content details.

None: Not yet available Lead (Pb-Free).

Pb-Free (RoHS): TI's terms "Lead-Free" or "Pb-Free" mean semiconductor products that are compatible with the current RoHS requirements for all 6 substances, including the requirement that lead not exceed 0.1% by weight in homogeneous materials. Where designed to be soldered at high temperatures, TI Pb-Free products are suitable for use in specified lead-free processes.

Green (RoHS & no Sb/Br): TI defines "Green" to mean "Pb-Free" and in addition, uses package materials that do not contain halogens, including bromine (Br) or antimony (Sb) above 0.1% of total product weight.

(3) MSL, Peak Temp. -- The Moisture Sensitivity Level rating according to the JEDEC industry standard classifications, and peak solder temperature.

Important Information and Disclaimer: The information provided on this page represents TI's knowledge and belief as of the date that it is provided. TI bases its knowledge and belief on information provided by third parties, and makes no representation or warranty as to the accuracy of such information. Efforts are underway to better integrate information from third parties. TI has taken and continues to take reasonable steps to provide representative and accurate information but may not have conducted destructive testing or chemical analysis on incoming materials and chemicals. TI and TI suppliers consider certain information to be proprietary, and thus CAS numbers and other limited information may not be available for release.

In no event shall TI's liability arising out of such information exceed the total purchase price of the TI part(s) at issue in this document sold by TI to Customer on an annual basis.

DL (R-PDSO-G**)

PLASTIC SMALL-OUTLINE PACKAGE

48 PINS SHOWN



- NOTES: A. All linear dimensions are in inches (millimeters).
 B. This drawing is subject to change without notice.
 C. Body dimensions do not include mold flash or protrusion not to exceed 0.006 (0,15).
 D. Falls within JEDEC MO-118

DGG (R-PDSO-G**)

PLASTIC SMALL-OUTLINE PACKAGE

48 PINS SHOWN



- NOTES: A. All linear dimensions are in millimeters.
 B. This drawing is subject to change without notice.
 C. Body dimensions do not include mold protrusion not to exceed 0,15.
 D. Falls within JEDEC MO-153

IMPORTANT NOTICE

Texas Instruments Incorporated and its subsidiaries (TI) reserve the right to make corrections, modifications, enhancements, improvements, and other changes to its products and services at any time and to discontinue any product or service without notice. Customers should obtain the latest relevant information before placing orders and should verify that such information is current and complete. All products are sold subject to TI's terms and conditions of sale supplied at the time of order acknowledgment.

TI warrants performance of its hardware products to the specifications applicable at the time of sale in accordance with TI's standard warranty. Testing and other quality control techniques are used to the extent TI deems necessary to support this warranty. Except where mandated by government requirements, testing of all parameters of each product is not necessarily performed.

TI assumes no liability for applications assistance or customer product design. Customers are responsible for their products and applications using TI components. To minimize the risks associated with customer products and applications, customers should provide adequate design and operating safeguards.

TI does not warrant or represent that any license, either express or implied, is granted under any TI patent right, copyright, mask work right, or other TI intellectual property right relating to any combination, machine, or process in which TI products or services are used. Information published by TI regarding third-party products or services does not constitute a license from TI to use such products or services or a warranty or endorsement thereof. Use of such information may require a license from a third party under the patents or other intellectual property of the third party, or a license from TI under the patents or other intellectual property of TI.

Reproduction of information in TI data books or data sheets is permissible only if reproduction is without alteration and is accompanied by all associated warranties, conditions, limitations, and notices. Reproduction of this information with alteration is an unfair and deceptive business practice. TI is not responsible or liable for such altered documentation.

Resale of TI products or services with statements different from or beyond the parameters stated by TI for that product or service voids all express and any implied warranties for the associated TI product or service and is an unfair and deceptive business practice. TI is not responsible or liable for any such statements.

Following are URLs where you can obtain information on other Texas Instruments products and application solutions:

Products		Applications	
Amplifiers	amplifier.ti.com	Audio	www.ti.com/audio
Data Converters	dataconverter.ti.com	Automotive	www.ti.com/automotive
DSP	dsp.ti.com	Broadband	www.ti.com/broadband
Interface	interface.ti.com	Digital Control	www.ti.com/digitalcontrol
Logic	logic.ti.com	Military	www.ti.com/military
Power Mgmt	power.ti.com	Optical Networking	www.ti.com/opticalnetwork
Microcontrollers	microcontroller.ti.com	Security	www.ti.com/security
		Telephony	www.ti.com/telephony
		Video & Imaging	www.ti.com/video
		Wireless	www.ti.com/wireless

Mailing Address: Texas Instruments
Post Office Box 655303 Dallas, Texas 75265