

# 18-Bit Registered Transceivers

## Features

- $I_{off}$  supports partial-power-down mode operation
- Edge-rate control circuitry for significantly improved noise characteristics
- Typical output skew < 250 ps
- ESD > 2000V
- TSSOP (19.6 mil pitch) and SSOP (25-mil pitch) packages
- Industrial temperature range of  $-40^{\circ}\text{C}$  to  $+85^{\circ}\text{C}$
- $V_{CC} = 5\text{V} \pm 10\%$

### CY74FCT16501T Features:

- 64 mA sink current, 32 mA source current
- Typical  $V_{OLP}$  (ground bounce) < 1.0V at  $V_{CC} = 5\text{V}$ ,  $T_A = 25^{\circ}\text{C}$

### CY74FCT162501T Features:

- Balanced 24 mA output drivers
- Reduced system switching noise
- Typical  $V_{OLP}$  (ground bounce) < 0.6V at  $V_{CC} = 5\text{V}$ ,  $T_A = 25^{\circ}\text{C}$

### CY74FCT162H501T Features:

- Bus hold retains last active state
- Eliminates the need for external pull-up or pull-down resistors

## Functional Description

These 18-bit universal bus transceivers can be operated in transparent, latched or clock modes by combining D-type latches and D-type flip-flops. Data flow in each direction is controlled by output enable (OEAB and OEBA), latch enable (LEAB and LEBA), and clock inputs (CLKAB and CLKBA). For A-to-B data flow, the device operates in transparent mode when LEAB is HIGH. When LEAB is LOW, the A data is latched if CLKAB is held at a HIGH or LOW logic level. If LEAB is LOW, the A bus data is stored in the latch/flip-flop on the LOW-to-HIGH transition of CLKAB. OEAB performs the output enable function on the B port. Data flow from B-to-A is similar to that of A-to-B and is controlled by OEBA, LEBA, and CLKBA.

This device is fully specified for partial-power-down applications using  $I_{off}$ . The  $I_{off}$  circuitry disables the outputs, preventing damaging current backflow through the device when it is powered down.

The CY74FCT16501T is ideally suited for driving high-capacitance loads and low-impedance backplanes.

THE CY74FCT162501T has 24-mA balanced output drivers with current limiting resistors in the outputs. This reduces the need for external terminating resistors and provides for minimal undershoot and reduced ground bounce. The CY74FCT162501T is ideal for driving transmission lines.

The CY74FCT162H501T is a 24-mA balanced output part, that has "bus hold" on the data inputs. The device retains the input's last state whenever the input goes to high impedance. This eliminates the need for pull-up/down resistors and prevents floating inputs.

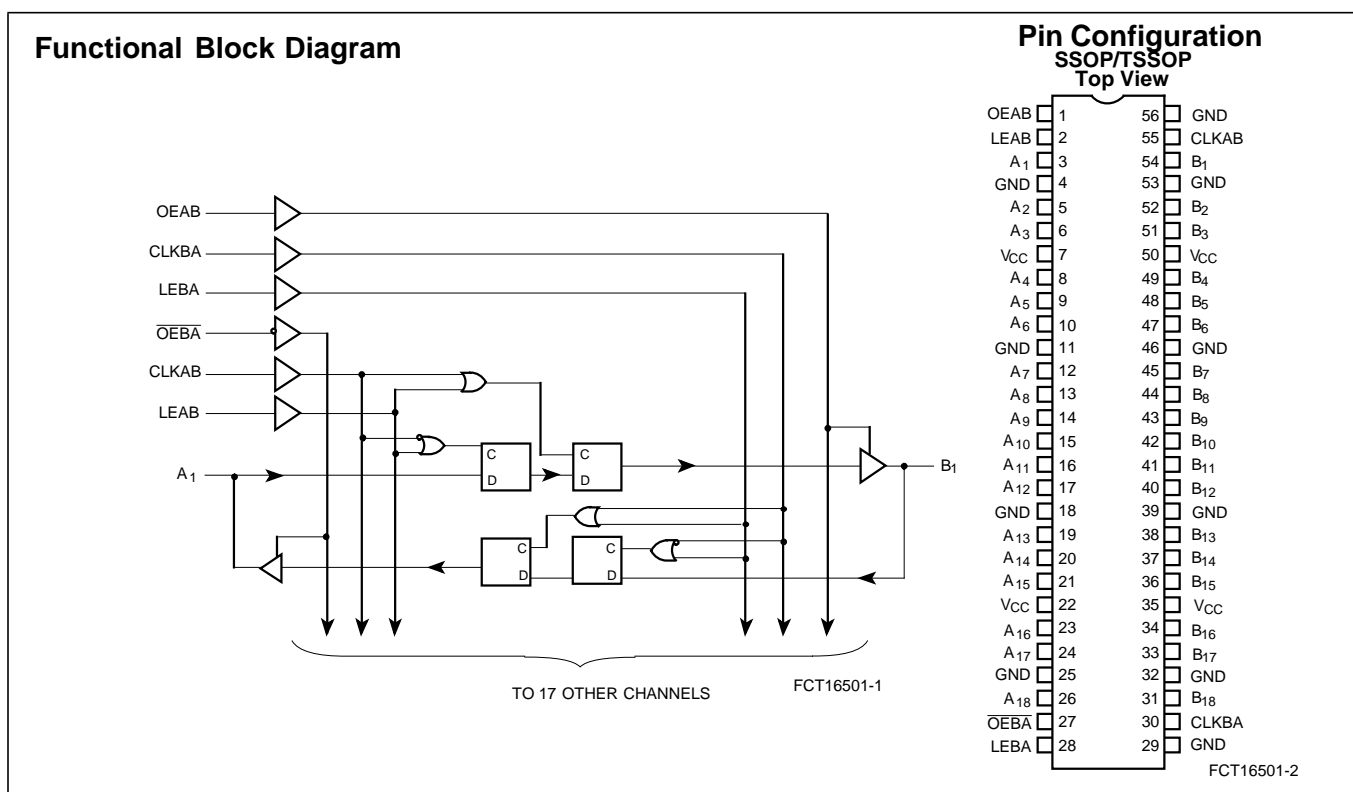

### Pin Description

Name	Description
OEAB	A-to-B Output Enable Input
OEBA	B-to-A Output Enable Input (Active LOW)
LEAB	A-to-B Latch Enable Input
LEBA	B-to-A Latch Enable Input
CLKAB	A-to-B Clock Input
CLKBA	B-to-A Clock Input
A	A-to-B Data Inputs or B-to-A Three-State Outputs <sup>[1]</sup>
B	B-to-A Data Inputs or A-to-B Three-State Outputs <sup>[1]</sup>

### Function Table<sup>[2, 3]</sup>

Inputs				Outputs	
OEAB	LEAB	CLKAB	A	B	
L	X	X	X	Z	
H	H	X	L	L	
H	H	X	H	H	
H	L	┐	L	L	
H	L	┐	H	H	
H	L	L	X	B <sup>[4]</sup>	
H	L	H	X	B <sup>[5]</sup>	

#### Notes:

- On the 74FCT162H501T these pins have bus hold.
- A-to-B data flow is shown. B-to-A data flow is similar but uses OEBA, LEBA, and CLKBA.
- H = HIGH Voltage Level  
L = LOW Voltage Level  
X = Don't Care  
Z = High-impedance  
┐ = LOW-to-HIGH Transition
- Output level before the indicated steady-state input conditions were established.
- Output level before the indicated steady-state input conditions were established, provided that CLKAB was HIGH before LEAB went LOW.
- Operation beyond the limits set forth may impair the useful life of the device. Unless otherwise noted, these limits are over the operating free-air temperature range.
- Unused inputs must always be connected to an appropriate logic voltage level, preferably either V<sub>CC</sub> or ground.

### Maximum Ratings<sup>[6, 7]</sup>

(Above which the useful life may be impaired. For user guidelines, not tested.)

Storage Temperature ..... -55°C to +125°C

Ambient Temperature with Power Applied..... -55°C to +125°C

DC Input Voltage..... -0.5V to +7.0V

DC Output Voltage..... -0.5V to +7.0V

DC Output Current (Maximum Sink Current/Pin)..... -60 to +120 mA

Power Dissipation..... 1.0W

Static Discharge Voltage ..... >2001V (per MIL-STD-883, Method 3015)

### Operating Range

Range	Ambient Temperature	V <sub>CC</sub>
Industrial	-40°C to +85°C	5V ± 10%

**Electrical Characteristics** Over the Operating Range

Parameter	Description	Test Conditions	Min.	Typ. <sup>[8]</sup>	Max.	Unit
V <sub>IH</sub>	Input HIGH Voltage		2.0			V
V <sub>IL</sub>	Input LOW Voltage				0.8	V
V <sub>H</sub>	Input Hysteresis <sup>[9]</sup>			100		mV
V <sub>IK</sub>	Input Clamp Diode Voltage	V <sub>CC</sub> =Min., I <sub>IN</sub> =-18 mA		-0.7	-1.2	V
I <sub>IH</sub>	Input HIGH Current	Standard	V <sub>CC</sub> =Max., V <sub>I</sub> =V <sub>CC</sub>		±1	μA
		Bus Hold			±100	
I <sub>IL</sub>	Input LOW Current	Standard	V <sub>CC</sub> =Max., V <sub>I</sub> =GND		±1	μA
		Bus Hold			±100	μA
I <sub>BBH</sub> I <sub>BBL</sub>	Bus Hold Sustain Current on Bus Hold Input <sup>[10]</sup>	V <sub>CC</sub> =Min., V <sub>I</sub> =2.0V V <sub>I</sub> =0.8V	-50			μA
			+50			μA
I <sub>BHHO</sub> I <sub>BHLO</sub>	Bus Hold Overdrive Current on Bus Hold Input <sup>[10]</sup>	V <sub>CC</sub> =Max., V <sub>I</sub> =1.5V			TBD	mA
I <sub>OZH</sub>	High Impedance Output Current (Three-State Output pins)	V <sub>CC</sub> =Max., V <sub>OUT</sub> =2.7V			±1	μA
I <sub>OZL</sub>	High Impedance Output Current (Three-State Output pins)	V <sub>CC</sub> =Max., V <sub>OUT</sub> =0.5V			±1	μA
I <sub>OS</sub>	Short Circuit Current <sup>[11]</sup>	V <sub>CC</sub> =Max., V <sub>OUT</sub> =GND	-80	-140	-200	mA
I <sub>O</sub>	Output Drive Current <sup>[11]</sup>	V <sub>CC</sub> =Max., V <sub>OUT</sub> =2.5V	-50		-180	mA
I <sub>OFF</sub>	Power-Off Disable	V <sub>CC</sub> =0V, V <sub>OUT</sub> ≤4.5V <sup>[12]</sup>			±1	μA

**Output Drive Characteristics for CY74FCT16501T**

Parameter	Description	Test Conditions	Min.	Typ. <sup>[8]</sup>	Max.	Unit
V <sub>OH</sub>	Output HIGH Voltage	V <sub>CC</sub> =Min., I <sub>OH</sub> =-3 mA	2.5	3.5		V
		V <sub>CC</sub> =Min., I <sub>OH</sub> =-15 mA	2.4	3.5		
		V <sub>CC</sub> =Min., I <sub>OH</sub> =-32 mA	2.0	3.0		
V <sub>OL</sub>	Output LOW Voltage	V <sub>CC</sub> =Min., I <sub>OL</sub> =64 mA		0.2	0.55	V

**Output Drive Characteristics for CY74FCT162501T, CY74FCT162H501T**

Parameter	Description	Test Conditions	Min.	Typ. <sup>[8]</sup>	Max.	Unit
I <sub>ODL</sub>	Output LOW Current <sup>[11]</sup>	V <sub>CC</sub> =5V, V <sub>IN</sub> =V <sub>IH</sub> or V <sub>IL</sub> , V <sub>OUT</sub> =1.5V	60	115	150	mA
I <sub>ODH</sub>	Output HIGH Current <sup>[11]</sup>	V <sub>CC</sub> =5V, V <sub>IN</sub> =V <sub>IH</sub> or V <sub>IL</sub> , V <sub>OUT</sub> =1.5V	-60	-115	-150	mA
V <sub>OH</sub>	Output HIGH Voltage	V <sub>CC</sub> =Min., I <sub>OH</sub> =-24 mA	2.4	3.3		V
V <sub>OL</sub>	Output LOW Voltage	V <sub>CC</sub> =Min., I <sub>OL</sub> =24 mA		0.3	0.55	V

**Notes:**

- Typical values are at V<sub>CC</sub>= 5.0V, T<sub>A</sub>= +25°C ambient.
- This parameter is specified but not tested.
- Pins with bus hold are described in Pin Description.
- Not more than one output should be shorted at a time. Duration of short should not exceed one second. The use of high-speed test apparatus and/or sample and hold techniques are preferable in order to minimize internal chip heating and more accurately reflect operational values. Otherwise prolonged shorting of a high output may raise the chip temperature well above normal and thereby cause invalid readings in other parametric tests. In any sequence of parameter tests, I<sub>OS</sub> tests should be performed last.
- Tested at +25°C.

**Capacitance<sup>[9]</sup>** ( $T_A = +25^\circ\text{C}$ ,  $f = 1.0\text{ MHz}$ )

Parameter	Description	Test Conditions	Typ. <sup>[8]</sup>	Max.	Unit
$C_{IN}$	Input Capacitance	$V_{IN} = 0V$	4.5	6.0	pF
$C_{OUT}$	Output Capacitance	$V_{OUT} = 0V$	5.5	8.0	pF

**Power Supply Characteristics**

Sym.	Parameter	Test Conditions <sup>[13]</sup>		Min.	Typ. <sup>[8]</sup>	Max.	Unit
$I_{CC}$	Quiescent Power Supply Current	$V_{CC} = \text{Max.}$	$V_{IN} \leq 0.2V$ $V_{IN} \geq V_{CC} - 0.2V$	—	5	500	$\mu\text{A}$
$\Delta I_{CC}$	Quiescent Power Supply Current TTL inputs HIGH	$V_{CC} = \text{Max.}, V_{IN} = 3.4V$ <sup>[14]</sup>		—	0.5	1.5	mA
$I_{CCD}$	Dynamic Power Supply Current <sup>[15]</sup>	$V_{CC} = \text{Max.}$ , Outputs Open OEAB= $\overline{\text{OEBA}} = V_{CC}$ or GND One Input Toggling, 50% Duty Cycle	$V_{IN} = V_{CC}$ or $V_{IN} = \text{GND}$	—	75	120	$\mu\text{A}/\text{MHz}$
$I_C$	Total Power Supply Current <sup>[16]</sup>	$V_{CC} = \text{Max.}$ , Outputs Open $f_0 = 10\text{MHz}$ (CLKAB) 50% Duty Cycle OEAB= $\overline{\text{OEBA}} = V_{CC}$ LEAB = GND, One Bit Toggling $f_1 = 5\text{MHz}$ , 50% Duty Cycle	$V_{IN} = V_{CC}$ or $V_{IN} = \text{GND}$	—	0.8	1.7	mA
			$V_{IN} = 3.4V$ or $V_{IN} = \text{GND}$	—	1.3	3.2	
		$V_{CC} = \text{Max.}$ , Outputs Open $f_0 = 10\text{MHz}$ (CLKAB) 50% Duty Cycle OEAB= $\overline{\text{OEBA}} = V_{CC}$ LEAB=GND Eighteen Bits Toggling $f_1 = 2.5\text{MHz}$ , 50% Duty Cycle	$V_{IN} = V_{CC}$ or $V_{IN} = \text{GND}$	—	3.8	6.5 <sup>[17]</sup>	
			$V_{IN} = 3.4V$ or $V_{IN} = \text{GND}$	—	8.5	20.8 <sup>[17]</sup>	

**Notes:**

13. For conditions shown as Max. or Min., use appropriate value specified under Electrical Characteristics for the applicable device type.

14. Per TTL driven input ( $V_{IN} = 3.4V$ ); all other inputs at  $V_{CC}$  or GND.

15. This parameter is not directly testable, but is derived for use in Total Power Supply.

16.  $I_C = I_{\text{QUIESCENT}} + I_{\text{INPUTS}} + I_{\text{DYNAMIC}}$   
 $I_C = I_{CC} + \Delta I_{CC} D_H N_T + I_{CCD} (f_0/2 + f_1 N_1)$   
 $I_{CC}$  = Quiescent Current with CMOS input levels  
 $\Delta I_{CC}$  = Power Supply Current for a TTL HIGH input ( $V_{IN} = 3.4V$ )  
 $D_H$  = Duty Cycle for TTL inputs HIGH  
 $N_T$  = Number of TTL inputs at  $D_H$   
 $I_{CCD}$  = Dynamic Current caused by an input transition pair (HLH or LHL)  
 $f_0$  = Clock frequency for registered devices, otherwise zero  
 $f_1$  = Input signal frequency  
 $N_1$  = Number of inputs changing at  $f_1$

All currents are in milliamps and all frequencies are in megahertz.

17. Values for these conditions are examples of the  $I_{CC}$  formula. These limits are specified but not tested.

**Switching Characteristics** Over the Operating Range<sup>[18]</sup>

Parameter	Description	CY74FCT16501AT CY74FCT162501AT		CY74FCT162501CT CY74FCT162H501CT		Unit	Fig. No. <sup>[19]</sup>	
		Min.	Max.	Min.	Max.			
f <sub>MAX</sub>	CLKAB or CLKBA frequency <sup>[20]</sup>	—	150	—	150	MHz	—	
t <sub>PLH</sub> t <sub>PHL</sub>	Propagation Delay A to B or B to A	1.5	5.1	1.5	4.6	ns	1,3	
t <sub>PLH</sub> t <sub>PHL</sub>	Propagation Delay LEBA to A, LEAB to B	1.5	5.6	1.5	5.3	ns	1,5	
t <sub>PLH</sub> t <sub>PHL</sub>	Propagation Delay CLKBA to A, CLKAB to B	1.5	5.6	1.5	5.3	ns	1,5	
t <sub>PZH</sub> t <sub>PZL</sub>	Output Enable Time OEBA to A, OEAB to B	1.5	6.0	1.5	5.6	ns	1,7,8	
t <sub>PHZ</sub> t <sub>PLZ</sub>	Output Disable Time OEBA to A, OEAB to B	1.5	5.6	1.5	5.2	ns	1,7,8	
t <sub>SU</sub>	Set-Up Time, HIGH or LOW A to CLKAB, B to CLKBA	3.0	—	3.0	—	ns	4	
t <sub>H</sub>	Hold Time HIGH or LOW A to CLKAB, B to CLKBA	0	—	0	—	ns	4	
t <sub>SU</sub>	Set-Up Time, HIGH or LOW A to LEAB, B to LEBA	Clock LOW	3.0	—	3.0	—	ns	4
		Clock HIGH	1.5	—	1.5	—	ns	4
t <sub>H</sub>	Hold Time, HIGH or LOW, A to LEAB, B to LEBA	1.5	—	1.5	—	ns	4	
t <sub>W</sub>	LEAB or LEBA Pulse Width HIGH <sup>[20]</sup>	3.0	—	3.0	—	ns	5	
t <sub>W</sub>	CLKAB or CLKBA Pulse Width HIGH or LOW <sup>[20]</sup>	3.0	—	3.0	—	ns	5	
t <sub>SK(O)</sub>	Output Skew <sup>[21]</sup>	—	0.5	—	0.5	ns	—	

**Notes:**

18. Minimum limits are specified, but not tested, on propagation delays.

19. See "Parameter Measurement Information" in the General Information section.

20. This parameter is guaranteed but not tested.

21. Skew between any two outputs of the same package switching in the same direction. This parameter ensured by design.

**Ordering Information CY74FCT16501T**

Speed (ns)	Ordering Code	Package Name	Package Type	Operating Range
5.1	CY74FCT16501ATPVC/PVCT	O56	56-Lead (300-Mil) SSOP	Industrial

**Ordering Information CY74FCT162501T**

Speed (ns)	Ordering Code	Package Name	Package Type	Operating Range
4.6	74FCT162501CTPACT	Z56	56-Lead (240-Mil) TSSOP	Industrial
	CY74FCT162501CTPVC	O56	56-Lead (300-Mil) SSOP	
	74FCT162501CTPVCT	O56	56-Lead (300-Mil) SSOP	
5.1	74FCT162501ATPACT	Z56	56-Lead (240-Mil) TSSOP	Industrial
	CY74FCT162501ATPVC	O56	56-Lead (300-Mil) SSOP	
	74FCT162501ATPVCT	O56	56-Lead (300-Mil) SSOP	

**Ordering Information CY74FCT162H501T**

Speed (ns)	Ordering Code	Package Name	Package Type	Operating Range
4.6	74FCT162H501CTPACT	Z56	56-Lead (240-Mil) TSSOP	Industrial
	74FCT162H501CTPVC/PVCT	O56	56-Lead (300-Mil) SSOP	

**Package Diagrams**

**56-Lead Shrunken Small Outline Package O56**

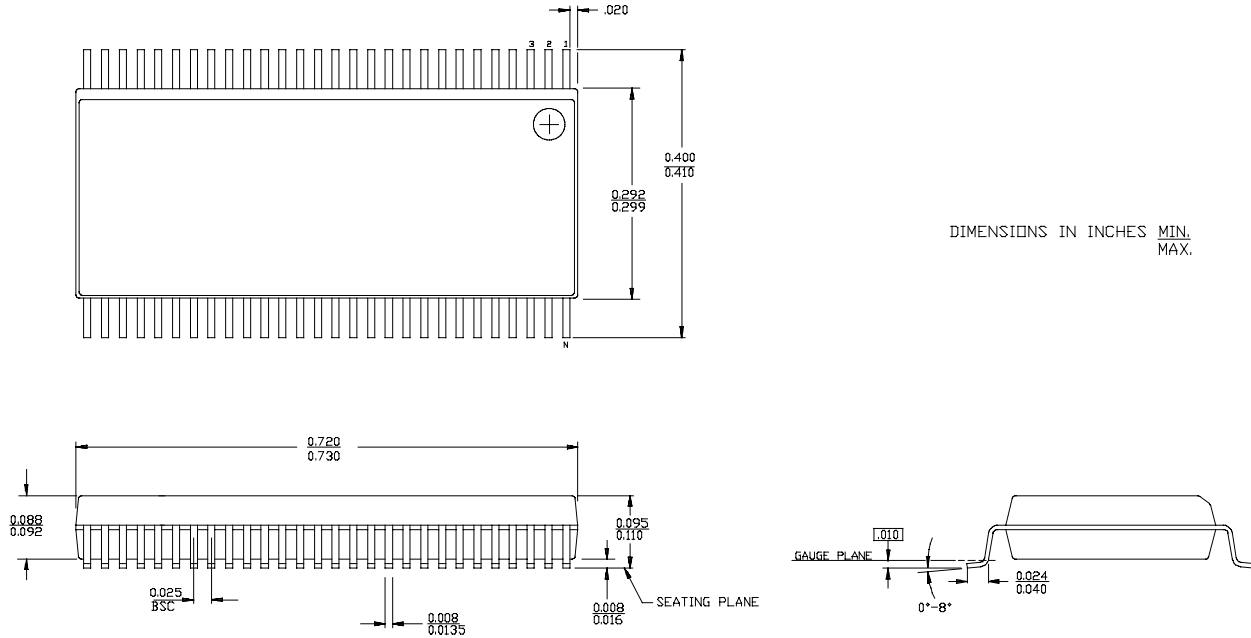

**56-Lead Thin Shrunken Small Outline Package Z56**

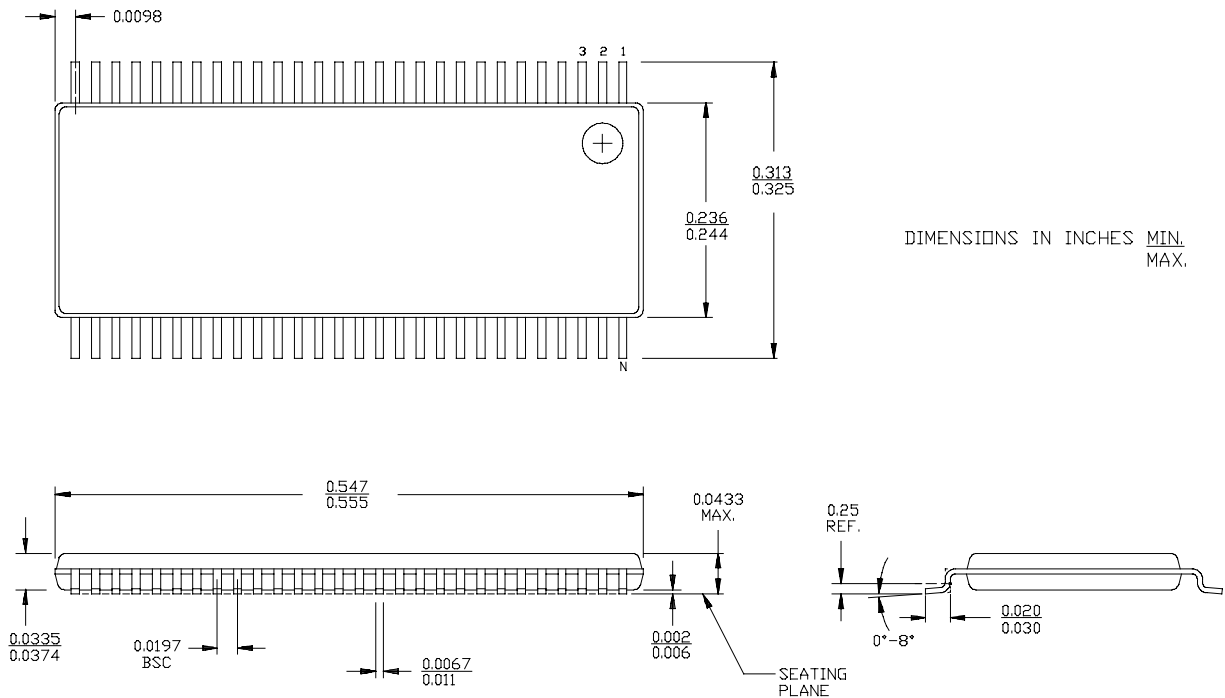

**PACKAGING INFORMATION**

Orderable Device	Status <sup>(1)</sup>	Package Type	Package Drawing	Pins	Package Qty	Eco Plan <sup>(2)</sup>	Lead/Ball Finish	MSL Peak Temp <sup>(3)</sup>
74FCT162501ATPACT	ACTIVE	TSSOP	DGG	56	2000	Pb-Free (RoHS)	CU NIPDAU	Level-1-250C-UNLIM
74FCT162501ATPVCT	ACTIVE	SSOP	DL	56	1000	None	CU NIPDAU	Level-1-235C-UNLIM
74FCT162501CTPACT	ACTIVE	TSSOP	DGG	56	2000	Pb-Free (RoHS)	CU NIPDAU	Level-1-250C-UNLIM
74FCT162501CTPVCT	ACTIVE	SSOP	DL	56	1000	None	CU NIPDAU	Level-1-235C-UNLIM
74FCT162501ETPACT	OBSOLETE	TSSOP	DGG	56		None	Call TI	Call TI
74FCT162501ETPVCT	OBSOLETE	SSOP	DL	56		None	Call TI	Call TI
74FCT162H501CTPACT	ACTIVE	TSSOP	DGG	56	2000	Pb-Free (RoHS)	CU NIPDAU	Level-1-250C-UNLIM
74FCT162H501CTPVC	ACTIVE	SSOP	DL	56	20	None	CU NIPDAU	Level-1-235C-UNLIM
74FCT162H501CTPVCT	ACTIVE	SSOP	DL	56	1000	None	CU NIPDAU	Level-1-235C-UNLIM
74FCT162H501ETPAC	OBSOLETE	TSSOP	DGG	56		None	Call TI	Call TI
74FCT162H501ETPACT	OBSOLETE	TSSOP	DGG	56		None	Call TI	Call TI
74FCT162H501ETPVC	OBSOLETE	SSOP	DL	56		None	Call TI	Call TI
74FCT162H501ETPVCT	OBSOLETE	SSOP	DL	56		None	Call TI	Call TI
CY74FCT162501ATPVC	ACTIVE	SSOP	DL	56	20	None	CU NIPDAU	Level-1-235C-UNLIM
CY74FCT162501CTPVC	ACTIVE	SSOP	DL	56	20	None	CU NIPDAU	Level-1-235C-UNLIM
CY74FCT162501ETPAC	OBSOLETE	TSSOP	DGG	56		None	Call TI	Call TI
CY74FCT162501ETPVC	OBSOLETE	SSOP	DL	56		None	Call TI	Call TI
CY74FCT16501ATPVC	ACTIVE	SSOP	DL	56	20	None	CU NIPDAU	Level-1-235C-UNLIM
CY74FCT16501ATPVCT	ACTIVE	SSOP	DL	56	1000	None	CU NIPDAU	Level-1-235C-UNLIM
CY74FCT16501ETPAC	OBSOLETE	TSSOP	DGG	56		None	Call TI	Call TI
CY74FCT16501ETPACT	OBSOLETE	TSSOP	DGG	56		None	Call TI	Call TI
CY74FCT16501ETPVC	OBSOLETE	SSOP	DL	56		None	Call TI	Call TI
CY74FCT16501ETPVCT	OBSOLETE	SSOP	DL	56		None	Call TI	Call TI

<sup>(1)</sup> The marketing status values are defined as follows:

**ACTIVE:** Product device recommended for new designs.

**LIFEBUY:** TI has announced that the device will be discontinued, and a lifetime-buy period is in effect.

**NRND:** Not recommended for new designs. Device is in production to support existing customers, but TI does not recommend using this part in a new design.

**PREVIEW:** Device has been announced but is not in production. Samples may or may not be available.

**OBSOLETE:** TI has discontinued the production of the device.

<sup>(2)</sup> Eco Plan - May not be currently available - please check <http://www.ti.com/productcontent> for the latest availability information and additional product content details.

**None:** Not yet available Lead (Pb-Free).

**Pb-Free (RoHS):** TI's terms "Lead-Free" or "Pb-Free" mean semiconductor products that are compatible with the current RoHS requirements for all 6 substances, including the requirement that lead not exceed 0.1% by weight in homogeneous materials. Where designed to be soldered at high temperatures, TI Pb-Free products are suitable for use in specified lead-free processes.

**Green (RoHS & no Sb/Br):** TI defines "Green" to mean "Pb-Free" and in addition, uses package materials that do not contain halogens, including bromine (Br) or antimony (Sb) above 0.1% of total product weight.

<sup>(3)</sup> MSL, Peak Temp. -- The Moisture Sensitivity Level rating according to the JEDEC industry standard classifications, and peak solder temperature.

**Important Information and Disclaimer:** The information provided on this page represents TI's knowledge and belief as of the date that it is provided. TI bases its knowledge and belief on information provided by third parties, and makes no representation or warranty as to the

accuracy of such information. Efforts are underway to better integrate information from third parties. TI has taken and continues to take reasonable steps to provide representative and accurate information but may not have conducted destructive testing or chemical analysis on incoming materials and chemicals. TI and TI suppliers consider certain information to be proprietary, and thus CAS numbers and other limited information may not be available for release.

In no event shall TI's liability arising out of such information exceed the total purchase price of the TI part(s) at issue in this document sold by TI to Customer on an annual basis.

DL (R-PDSO-G\*\*)

PLASTIC SMALL-OUTLINE PACKAGE

48 PINS SHOWN



- NOTES: A. All linear dimensions are in inches (millimeters).  
 B. This drawing is subject to change without notice.  
 C. Body dimensions do not include mold flash or protrusion not to exceed 0.006 (0,15).  
 D. Falls within JEDEC MO-118

DGG (R-PDSO-G\*\*)

PLASTIC SMALL-OUTLINE PACKAGE

48 PINS SHOWN



- NOTES: A. All linear dimensions are in millimeters.  
 B. This drawing is subject to change without notice.  
 C. Body dimensions do not include mold protrusion not to exceed 0,15.  
 D. Falls within JEDEC MO-153

## IMPORTANT NOTICE

Texas Instruments Incorporated and its subsidiaries (TI) reserve the right to make corrections, modifications, enhancements, improvements, and other changes to its products and services at any time and to discontinue any product or service without notice. Customers should obtain the latest relevant information before placing orders and should verify that such information is current and complete. All products are sold subject to TI's terms and conditions of sale supplied at the time of order acknowledgment.

TI warrants performance of its hardware products to the specifications applicable at the time of sale in accordance with TI's standard warranty. Testing and other quality control techniques are used to the extent TI deems necessary to support this warranty. Except where mandated by government requirements, testing of all parameters of each product is not necessarily performed.

TI assumes no liability for applications assistance or customer product design. Customers are responsible for their products and applications using TI components. To minimize the risks associated with customer products and applications, customers should provide adequate design and operating safeguards.

TI does not warrant or represent that any license, either express or implied, is granted under any TI patent right, copyright, mask work right, or other TI intellectual property right relating to any combination, machine, or process in which TI products or services are used. Information published by TI regarding third-party products or services does not constitute a license from TI to use such products or services or a warranty or endorsement thereof. Use of such information may require a license from a third party under the patents or other intellectual property of the third party, or a license from TI under the patents or other intellectual property of TI.

Reproduction of information in TI data books or data sheets is permissible only if reproduction is without alteration and is accompanied by all associated warranties, conditions, limitations, and notices. Reproduction of this information with alteration is an unfair and deceptive business practice. TI is not responsible or liable for such altered documentation.

Resale of TI products or services with statements different from or beyond the parameters stated by TI for that product or service voids all express and any implied warranties for the associated TI product or service and is an unfair and deceptive business practice. TI is not responsible or liable for any such statements.

Following are URLs where you can obtain information on other Texas Instruments products and application solutions:

<b>Products</b>		<b>Applications</b>	
Amplifiers	<a href="http://amplifier.ti.com">amplifier.ti.com</a>	Audio	<a href="http://www.ti.com/audio">www.ti.com/audio</a>
Data Converters	<a href="http://dataconverter.ti.com">dataconverter.ti.com</a>	Automotive	<a href="http://www.ti.com/automotive">www.ti.com/automotive</a>
DSP	<a href="http://dsp.ti.com">dsp.ti.com</a>	Broadband	<a href="http://www.ti.com/broadband">www.ti.com/broadband</a>
Interface	<a href="http://interface.ti.com">interface.ti.com</a>	Digital Control	<a href="http://www.ti.com/digitalcontrol">www.ti.com/digitalcontrol</a>
Logic	<a href="http://logic.ti.com">logic.ti.com</a>	Military	<a href="http://www.ti.com/military">www.ti.com/military</a>
Power Mgmt	<a href="http://power.ti.com">power.ti.com</a>	Optical Networking	<a href="http://www.ti.com/opticalnetwork">www.ti.com/opticalnetwork</a>
Microcontrollers	<a href="http://microcontroller.ti.com">microcontroller.ti.com</a>	Security	<a href="http://www.ti.com/security">www.ti.com/security</a>
		Telephony	<a href="http://www.ti.com/telephony">www.ti.com/telephony</a>
		Video & Imaging	<a href="http://www.ti.com/video">www.ti.com/video</a>
		Wireless	<a href="http://www.ti.com/wireless">www.ti.com/wireless</a>

Mailing Address: Texas Instruments  
Post Office Box 655303 Dallas, Texas 75265