

SN54ALS323, SN74ALS323 8-BIT UNIVERSAL SHIFT/STORAGE REGISTERS WITH SYNCHRONOUS CLEAR AND 3-STATE OUTPUTS

SDAS267A – DECEMBER 1982 – REVISED DECEMBER 1994

- **Multiplexed I/O Ports Provide Improved Bit Density**
- **Four Modes of Operation:**
 - Hold (Store)
 - Shift Right
 - Shift Left
 - Load Data
- **Operate With Outputs Enabled or at High Impedance**
- **3-State Outputs Drive Bus Lines Directly**
- **Can Be Cascaded for n-Bit Word Lengths**
- **Synchronous Clear**
- **Applications:**
 - Stacked or Push-Down Registers
 - Buffer Storage
 - Accumulator Registers
- **Package Options Include Plastic Small-Outline (DW) Packages, Ceramic Chip Carriers (FK), and Standard Plastic (N) and Ceramic (J) 300-mil DIPs**

description

These 8-bit universal shift/storage registers feature multiplexed input/output (I/O) ports to achieve full 8-bit data handling in a 20-pin package. Two function-select (S0, S1) inputs and two output-enable ($\overline{OE1}$, $\overline{OE2}$) inputs can be used to choose the modes of operation listed in the function table.

Synchronous parallel loading is accomplished by taking both S0 and S1 high. This places the 3-state outputs in the high-impedance state and permits data applied on the I/O ports to be clocked into the register. Reading out of the register can be accomplished while the outputs are enabled in any mode. Clearing occurs synchronously when the clear (\overline{CLR}) input is low. Taking either $\overline{OE1}$ or $\overline{OE2}$ high disables the outputs but has no effect on clearing, shifting, or storing data.

The SN54ALS323 is characterized for operation over the full military temperature range of -55°C to 125°C . The SN74ALS323 is characterized for operation from 0°C to 70°C .

**SN54ALS323 . . . J PACKAGE
SN74ALS323 . . . DW OR N PACKAGE
(TOP VIEW)**

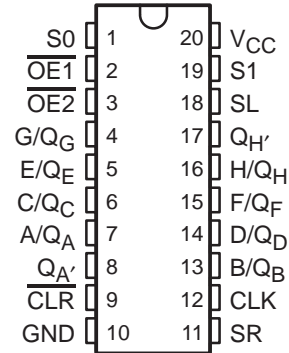

**SN54ALS323 . . . FK PACKAGE
(TOP VIEW)**

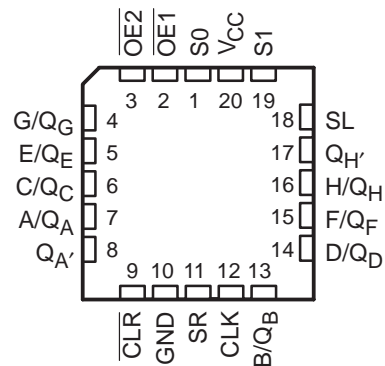

SN54ALS323, SN74ALS323

8-BIT UNIVERSAL SHIFT/STORAGE REGISTERS

WITH SYNCHRONOUS CLEAR AND 3-STATE OUTPUTS

SDAS267A – DECEMBER 1982 – REVISED DECEMBER 1994

FUNCTION TABLE

MODE	INPUTS								I/O PORTS								OUTPUTS			
	CLR	S1	S0	OE1†	OE2†	CLK	SL	SR	A/QA	B/QB	C/QC	D/QD	E/QE	F/QF	G/QG	H/QH	QA'	QH'		
Clear	L	X	L	L	L	↑	X	X	L	L	L	L	L	L	L	L	L	L	L	L
	L	L	X	L	L	↑	X	X	L	L	L	L	L	L	L	L	L	L	L	L
	L	H	H	X	X	↑	X	X	X	X	X	X	X	X	X	X	X	X	L	L
Hold	H	L	L	L	L	X	X	X	QA0	QB0	QC0	QD0	QE0	QF0	QG0	QH0	QA0	QH0	QA0	QH0
	H	X	X	L	L	L	X	X	QA0	QB0	QC0	QD0	QE0	QF0	QG0	QH0	QA0	QH0	QA0	QH0
Shift Right	H	L	H	L	L	↑	X	H	H	QA _n	QB _n	QC _n	QD _n	QE _n	QF _n	QG _n	H	QA _n	H	QA _n
	H	L	H	L	L	↑	X	L	L	QA _n	QB _n	QC _n	QD _n	QE _n	QF _n	QG _n	L	QA _n	L	QA _n
Shift Left	H	H	L	L	L	↑	H	X	QB _n	QC _n	QD _n	QE _n	QF _n	QG _n	QH _n	H	QB _n	H	QB _n	QB _n
	H	H	L	L	L	↑	L	X	QB _n	QC _n	QD _n	QE _n	QF _n	QG _n	QH _n	L	QB _n	L	QB _n	QB _n
Load	H	H	H	X	X	↑	X	X	a	b	c	d	e	f	g	h	a	h	a	h

NOTE: a . . . h = the level of the steady-state input at inputs A through H, respectively. This data is loaded into the flip-flops while the flip-flop outputs are isolated from the I/O terminals.

† When one or both output-enable inputs are high, the eight I/O terminals are disabled to the high-impedance state; however, sequential operation or clearing of the register is not affected.

logic symbol†

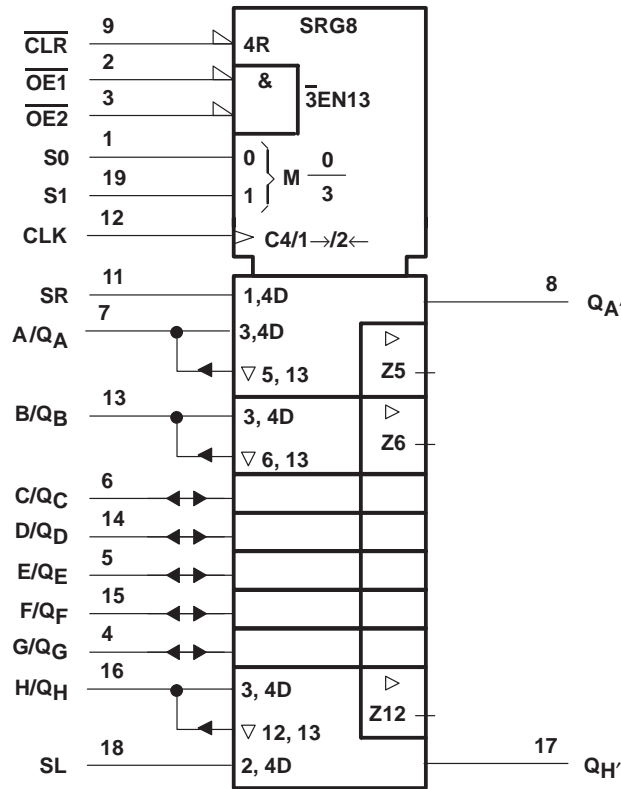

† This symbol is in accordance with ANSI/IEEE Std 91-1984 and IEC Publication 617-12.

SN54ALS323, SN74ALS323
8-BIT UNIVERSAL SHIFT/STORAGE REGISTERS
WITH SYNCHRONOUS CLEAR AND 3-STATE OUTPUTS

SDAS267A – DECEMBER 1982 – REVISED DECEMBER 1994

logic diagram (positive logic)

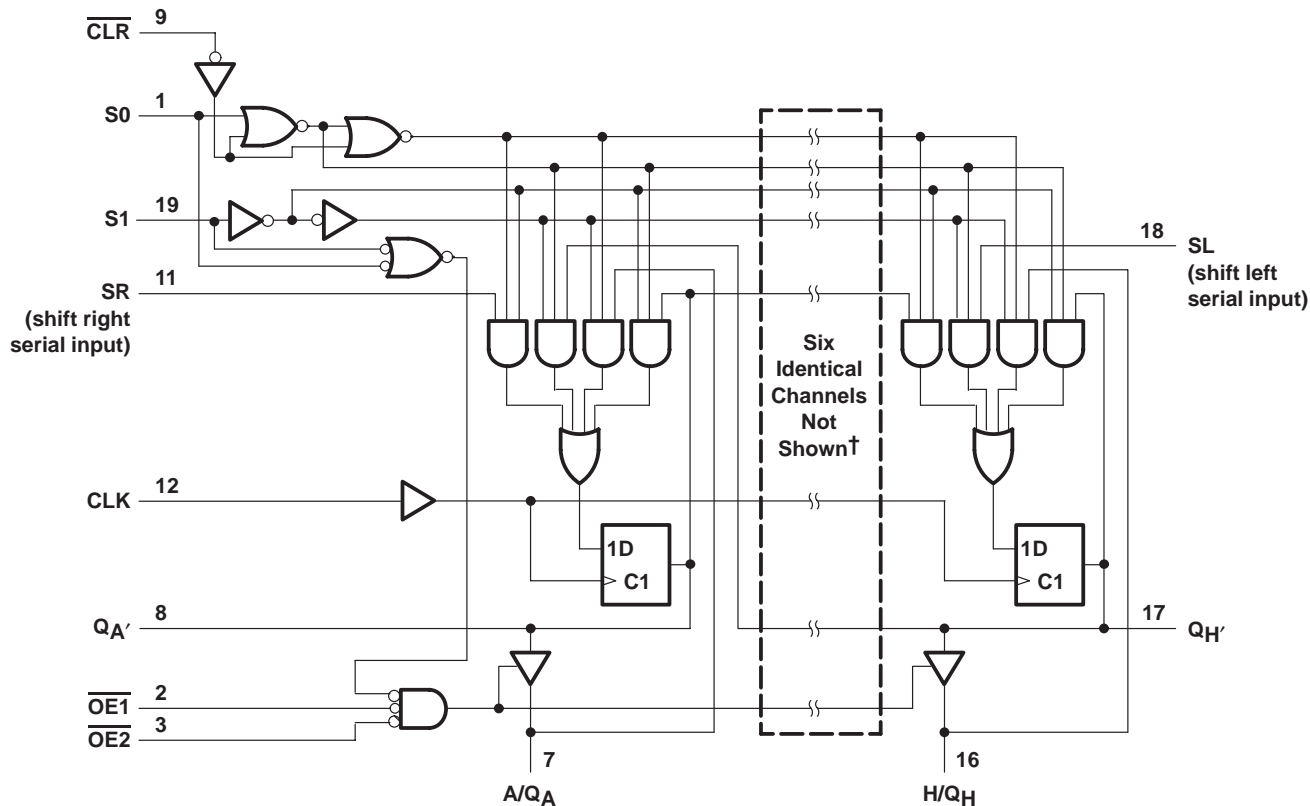

† I/O ports not shown: B/Q_B (13), C/Q_C (6), D/Q_D (14), E/Q_E (5), F/Q_F (15), and G/Q_G (4).

absolute maximum ratings over operating free-air temperature range (unless otherwise noted)‡

Supply voltage, V_{CC}	7 V
Input voltage, V_I : All inputs	7 V
I/O ports	5.5 V
Operating free-air temperature range, T_A : SN54ALS323	-55°C to 125°C
SN74ALS323	0°C to 70°C
Storage temperature range	-65°C to 150°C

‡ Stresses beyond those listed under "absolute maximum ratings" may cause permanent damage to the device. These are stress ratings only, and functional operation of the device at these or any other conditions beyond those indicated under "recommended operating conditions" is not implied. Exposure to absolute-maximum-rated conditions for extended periods may affect device reliability.

SN54ALS323, SN74ALS323

8-BIT UNIVERSAL SHIFT/STORAGE REGISTERS

WITH SYNCHRONOUS CLEAR AND 3-STATE OUTPUTS

SDAS267A – DECEMBER 1982 – REVISED DECEMBER 1994

recommended operating conditions

		SN54ALS323			SN74ALS323			UNIT
		MIN	NOM	MAX	MIN	NOM	MAX	
V_{CC}	Supply voltage	4.5	5	5.5	4.5	5	5.5	V
V_{IH}	High-level input voltage	2			2			V
V_{IL}	Low-level input voltage			0.7			0.8	V
I_{OH}	High-level output current	Q_A' or Q_H'		-0.4			-0.4	mA
		Q_A thru Q_H		-1			-2.6	
I_{OL}	Low-level output current	Q_A' or Q_H'		4			8	mA
		Q_A thru Q_H		12			24	
T_A	Operating free-air temperature	-55		125	0		70	°C

electrical characteristics over recommended operating free-air temperature range (unless otherwise noted)

PARAMETER		TEST CONDITIONS		SN54ALS323			SN74ALS323			UNIT
				MIN	TYP†	MAX	MIN	TYP†	MAX	
V_{IK}		$V_{CC} = 4.5\text{ V}$,	$I_I = -18\text{ mA}$			-1.5			-1.5	V
V_{OH}	Any output	$V_{CC} = 4.5\text{ V to }5.5\text{ V}$,	$I_{OH} = -0.4\text{ mA}$	$V_{CC} - 2$		$V_{CC} - 2$				V
	Q_A thru Q_H	$V_{CC} = 4.5\text{ V}$	$I_{OH} = -1\text{ mA}$	2.4	3.3					
V_{OL}	Q_A' or Q_H'	$V_{CC} = 4.5\text{ V}$	$I_{OL} = 4\text{ mA}$	0.25	0.4	0.25	0.4			V
			$I_{OL} = 8\text{ mA}$			0.35	0.5			
	Q_A thru Q_H	$V_{CC} = 4.5\text{ V}$	$I_{OL} = 12\text{ mA}$	0.25	0.4	0.25	0.4			
			$I_{OL} = 24\text{ mA}$			0.35	0.5			
I_I	A thru H	$V_{CC} = 5.5\text{ V}$	$V_I = 5.5\text{ V}$			0.1			0.1	mA
	Any others		$V_I = 7\text{ V}$			0.1			0.1	
$I_{IH}‡$		$V_{CC} = 5.5\text{ V}$,	$V_I = 2.7\text{ V}$			20			20	µA
$I_{IL}‡$	S0, S1, SR, SL	$V_{CC} = 5.5\text{ V}$,	$V_I = 0.4\text{ V}$			-0.2			-0.2	mA
	Any others					-0.1			-0.1	
$I_{OS}§$	Q_A' or Q_H'	$V_{CC} = 5.5\text{ V}$,	$V_O = 2.25\text{ V}$	-15	-70	-15	-70			mA
	Q_A thru Q_H			-20	-112	-30	-112			
I_{CC}		$V_{CC} = 5.5\text{ V}$	Outputs high	15	28	15	28			mA
			Outputs low	22	38	22	38			
			Outputs disabled	23	40	23	40			

† All typical values are at $V_{CC} = 5\text{ V}$, $T_A = 25^\circ\text{C}$.

‡ For I/O ports (Q_A thru Q_H), the parameters I_{IH} and I_{IL} include the off-state output current.

§ The output conditions have been chosen to produce a current that closely approximates one half of the true short-circuit output current, I_{OS} .

SN54ALS323, SN74ALS323
8-BIT UNIVERSAL SHIFT/STORAGE REGISTERS
WITH SYNCHRONOUS CLEAR AND 3-STATE OUTPUTS

SDAS267A – DECEMBER 1982 – REVISED DECEMBER 1994

timing requirements over recommended ranges of supply voltage and operating free-air temperature (unless otherwise noted)

			SN54ALS323		SN74ALS323		UNIT
			MIN	MAX	MIN	MAX	
f_{clock}	Clock frequency (at 50% duty cycle)		0	17	0	17	MHz
t_w	Pulse duration		CLK high or low		22	16.5	ns
t_{su}	Setup time before CLK \uparrow	S0 or S1	25		20		ns
		Serial or parallel data	High	18		16	
			Low	15		6	
	$\overline{\text{CLR}}$ active	25		20			
	Inactive-state setup time before CLK \uparrow \dagger	$\overline{\text{CLR}}$	18		16		
t_h	Hold time after CLK \uparrow	S0 or S1	0		0		ns
		Serial or parallel data	0		0		

\dagger Inactive-state setup time is also referred to as recovery time.

switching characteristics (see Figure 1)

PARAMETER	FROM (INPUT)	TO (OUTPUT)	V _{CC} = 4.5 V to 5.5 V, C _L = 50 pF, R1 = 500 Ω , R2 = 500 Ω , T _A = MIN to MAX \ddagger				UNIT
			SN54ALS323		SN74ALS323		
			MIN	MAX	MIN	MAX	
f_{max}			17		17	MHz	
t_{PLH}	CLK	Q _A thru Q _H	2	19	4	13	ns
t_{PHL}			4	25	7	19	
t_{PLH}	CLK	Q _{A'} or Q _{H'}	2	21	5	15	ns
t_{PHL}			4	25	8	18	
t_{PZH}	$\overline{\text{OE1}}, \overline{\text{OE2}}$	Q _A thru Q _H	5	22	6	16	ns
t_{PZL}			6	27	8	22	
t_{PZH}	S0, S1	Q _A thru Q _H	5	27	7	17	ns
t_{PZL}			6	27	8	22	
t_{PHZ}	$\overline{\text{OE1}}, \overline{\text{OE2}}$	Q _A thru Q _H	1	15	1	8	ns
t_{PLZ}			4	38	5	15	
t_{PHZ}	S0, S1	Q _A thru Q _H	1	16	1	12	ns
t_{PLZ}			4	34	8	25	

\ddagger For conditions shown as MIN or MAX, use the appropriate value specified under recommended operating conditions.

SN54ALS323, SN74ALS323
8-BIT UNIVERSAL SHIFT/STORAGE REGISTERS
WITH SYNCHRONOUS CLEAR AND 3-STATE OUTPUTS

SDAS267A – DECEMBER 1982 – REVISED DECEMBER 1994

PARAMETER MEASUREMENT INFORMATION
SERIES 54ALS/74ALS AND 54AS/74AS DEVICES

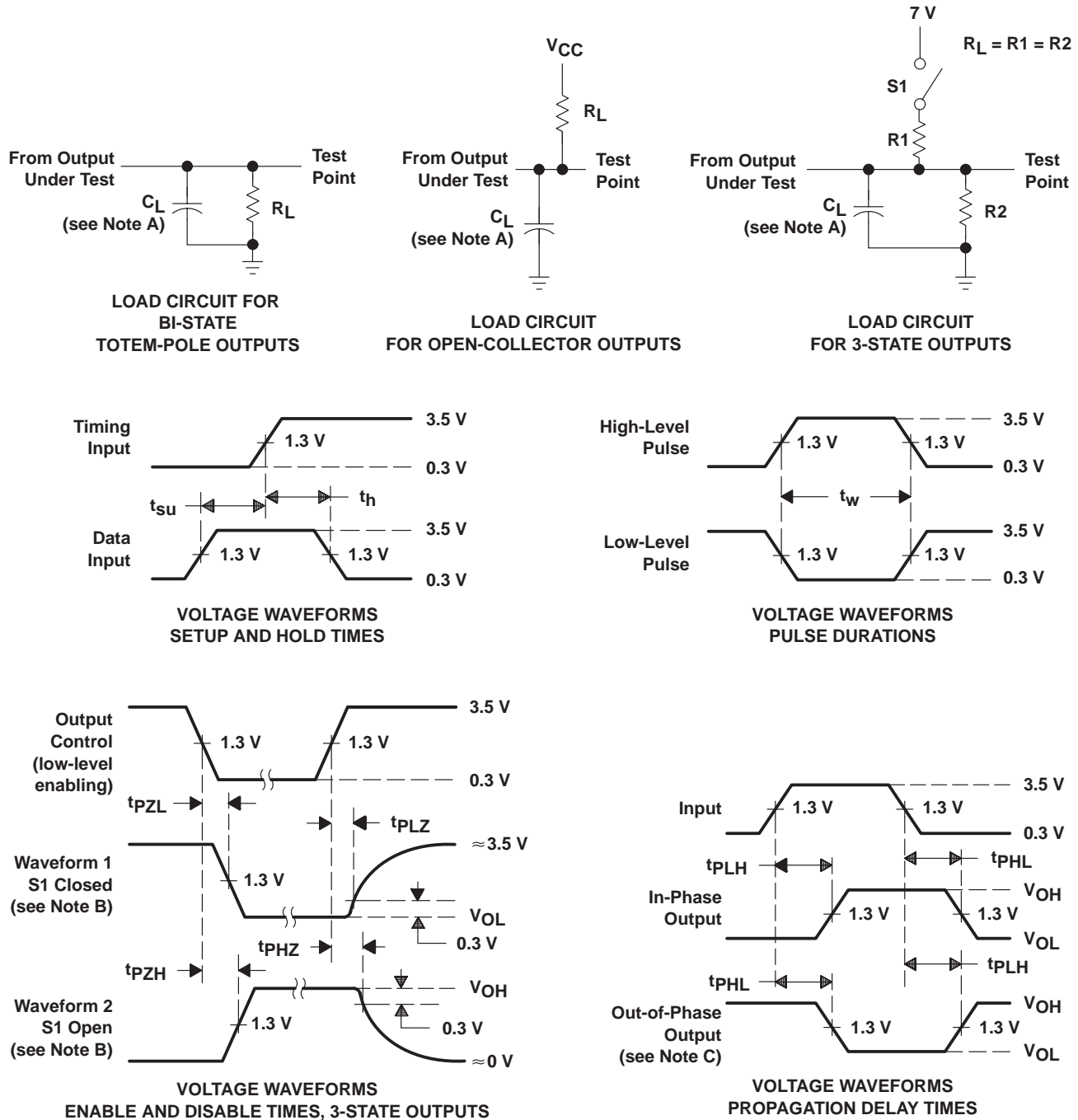

- NOTES: A. C_L includes probe and jig capacitance.
 B. Waveform 1 is for an output with internal conditions such that the output is low except when disabled by the output control. Waveform 2 is for an output with internal conditions such that the output is high except when disabled by the output control.
 C. When measuring propagation delay items of 3-state outputs, switch S1 is open.
 D. All input pulses have the following characteristics: $PRR \leq 1$ MHz, $t_r = t_f = 2$ ns, duty cycle = 50%.
 E. The outputs are measured one at a time with one transition per measurement.

Figure 1. Load Circuits and Voltage Waveforms

PACKAGING INFORMATION

Orderable Device	Status ⁽¹⁾	Package Type	Package Drawing	Pins	Package Qty	Eco Plan ⁽²⁾	Lead/Ball Finish	MSL Peak Temp ⁽³⁾
83021022A	ACTIVE	LCCC	FK	20	1	None	Call TI	Level-NC-NC-NC
8302102RA	ACTIVE	CDIP	J	20	1	None	Call TI	Level-NC-NC-NC
8302102SA	ACTIVE	CFP	W	20	1	None	Call TI	Level-NC-NC-NC
SN54ALS323J	ACTIVE	CDIP	J	20	1	None	Call TI	Level-NC-NC-NC
SN74ALS323DW	ACTIVE	SOIC	DW	20	25	Pb-Free (RoHS)	CU NIPDAU	Level-2-250C-1 YEAR/ Level-1-235C-UNLIM
SN74ALS323DWR	ACTIVE	SOIC	DW	20	2000	Pb-Free (RoHS)	CU NIPDAU	Level-2-250C-1 YEAR/ Level-1-235C-UNLIM
SN74ALS323N	ACTIVE	PDIP	N	20	20	Pb-Free (RoHS)	CU NIPDAU	Level-NC-NC-NC
SN74ALS323N3	OBSOLETE	PDIP	N	20		None	Call TI	Call TI
SN74ALS323NSR	ACTIVE	SO	NS	20	2000	Pb-Free (RoHS)	CU NIPDAU	Level-2-260C-1 YEAR/ Level-1-235C-UNLIM
SNJ54ALS323FK	ACTIVE	LCCC	FK	20	1	None	Call TI	Level-NC-NC-NC
SNJ54ALS323J	ACTIVE	CDIP	J	20	1	None	Call TI	Level-NC-NC-NC
SNJ54ALS323W	ACTIVE	CFP	W	20	1	None	Call TI	Level-NC-NC-NC

⁽¹⁾ The marketing status values are defined as follows:

ACTIVE: Product device recommended for new designs.

LIFEBUY: TI has announced that the device will be discontinued, and a lifetime-buy period is in effect.

NRND: Not recommended for new designs. Device is in production to support existing customers, but TI does not recommend using this part in a new design.

PREVIEW: Device has been announced but is not in production. Samples may or may not be available.

OBSOLETE: TI has discontinued the production of the device.

⁽²⁾ Eco Plan - May not be currently available - please check <http://www.ti.com/productcontent> for the latest availability information and additional product content details.

None: Not yet available Lead (Pb-Free).

Pb-Free (RoHS): TI's terms "Lead-Free" or "Pb-Free" mean semiconductor products that are compatible with the current RoHS requirements for all 6 substances, including the requirement that lead not exceed 0.1% by weight in homogeneous materials. Where designed to be soldered at high temperatures, TI Pb-Free products are suitable for use in specified lead-free processes.

Green (RoHS & no Sb/Br): TI defines "Green" to mean "Pb-Free" and in addition, uses package materials that do not contain halogens, including bromine (Br) or antimony (Sb) above 0.1% of total product weight.

⁽³⁾ MSL, Peak Temp. -- The Moisture Sensitivity Level rating according to the JEDEC industry standard classifications, and peak solder temperature.

Important Information and Disclaimer: The information provided on this page represents TI's knowledge and belief as of the date that it is provided. TI bases its knowledge and belief on information provided by third parties, and makes no representation or warranty as to the accuracy of such information. Efforts are underway to better integrate information from third parties. TI has taken and continues to take reasonable steps to provide representative and accurate information but may not have conducted destructive testing or chemical analysis on incoming materials and chemicals. TI and TI suppliers consider certain information to be proprietary, and thus CAS numbers and other limited information may not be available for release.

In no event shall TI's liability arising out of such information exceed the total purchase price of the TI part(s) at issue in this document sold by TI to Customer on an annual basis.

IMPORTANT NOTICE

Texas Instruments Incorporated and its subsidiaries (TI) reserve the right to make corrections, modifications, enhancements, improvements, and other changes to its products and services at any time and to discontinue any product or service without notice. Customers should obtain the latest relevant information before placing orders and should verify that such information is current and complete. All products are sold subject to TI's terms and conditions of sale supplied at the time of order acknowledgment.

TI warrants performance of its hardware products to the specifications applicable at the time of sale in accordance with TI's standard warranty. Testing and other quality control techniques are used to the extent TI deems necessary to support this warranty. Except where mandated by government requirements, testing of all parameters of each product is not necessarily performed.

TI assumes no liability for applications assistance or customer product design. Customers are responsible for their products and applications using TI components. To minimize the risks associated with customer products and applications, customers should provide adequate design and operating safeguards.

TI does not warrant or represent that any license, either express or implied, is granted under any TI patent right, copyright, mask work right, or other TI intellectual property right relating to any combination, machine, or process in which TI products or services are used. Information published by TI regarding third-party products or services does not constitute a license from TI to use such products or services or a warranty or endorsement thereof. Use of such information may require a license from a third party under the patents or other intellectual property of the third party, or a license from TI under the patents or other intellectual property of TI.

Reproduction of information in TI data books or data sheets is permissible only if reproduction is without alteration and is accompanied by all associated warranties, conditions, limitations, and notices. Reproduction of this information with alteration is an unfair and deceptive business practice. TI is not responsible or liable for such altered documentation.

Resale of TI products or services with statements different from or beyond the parameters stated by TI for that product or service voids all express and any implied warranties for the associated TI product or service and is an unfair and deceptive business practice. TI is not responsible or liable for any such statements.

Following are URLs where you can obtain information on other Texas Instruments products and application solutions:

Products		Applications	
Amplifiers	amplifier.ti.com	Audio	www.ti.com/audio
Data Converters	dataconverter.ti.com	Automotive	www.ti.com/automotive
DSP	dsp.ti.com	Broadband	www.ti.com/broadband
Interface	interface.ti.com	Digital Control	www.ti.com/digitalcontrol
Logic	logic.ti.com	Military	www.ti.com/military
Power Mgmt	power.ti.com	Optical Networking	www.ti.com/opticalnetwork
Microcontrollers	microcontroller.ti.com	Security	www.ti.com/security
		Telephony	www.ti.com/telephony
		Video & Imaging	www.ti.com/video
		Wireless	www.ti.com/wireless

Mailing Address: Texas Instruments
Post Office Box 655303 Dallas, Texas 75265