

ADS7810

12-Bit 800kHz Sampling CMOS ANALOG-to-DIGITAL CONVERTER

FEATURES

- 1.25 μ s THROUGHPUT TIME
- STANDARD ± 10 V INPUT RANGE
- 69dB min SINAD WITH 250kHz INPUT
- $\pm 3/4$ LSB max INL AND ± 1 LSB max DNL
- INTERNAL REFERENCE
- COMPLETE WITH S/H, REF, CLOCK, ETC.
- PARALLEL DATA w/LATCHES
- 28-PIN SOIC

DESCRIPTION

The ADS7810 is a complete 12-bit sampling A/D using state-of-the-art CMOS structures. It contains a complete 12-bit capacitor-based SAR A/D with inherent S/H, reference, clock, interface for microprocessor use, and three-state output drivers.

The ADS7810 is specified at an 800kHz sampling rate, and guaranteed over the full temperature range. Laser-trimmed scaling resistors provide the industry-standard ± 10 V input range, while an innovative design allows operation from ± 5 V supplies.

The 28-pin ADS7810 is available in a plastic SOIC fully specified for operation over the industrial -40°C to $+85^{\circ}\text{C}$ range.

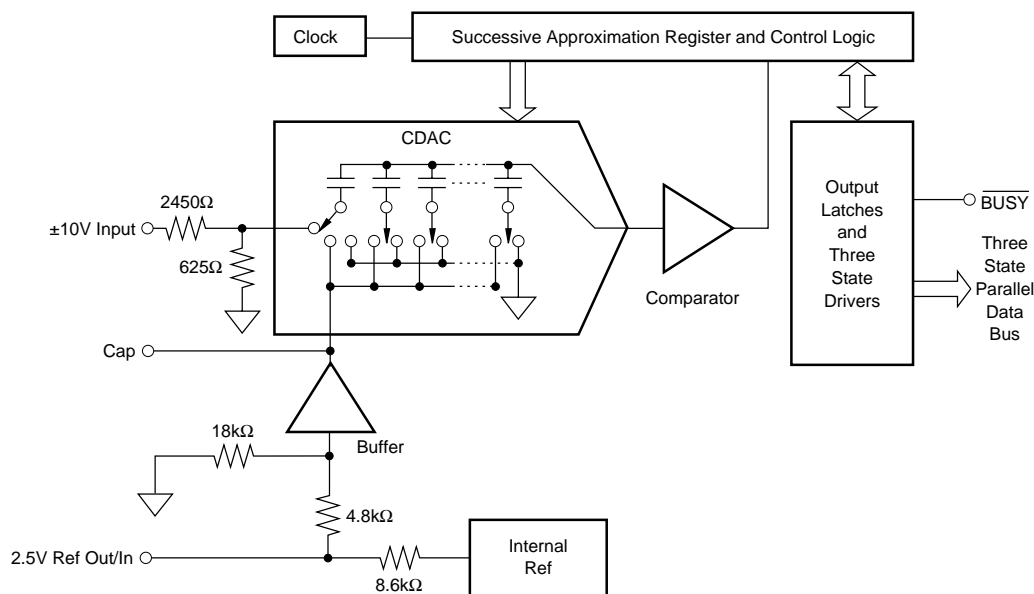

International Airport Industrial Park • Mailing Address: PO Box 11400, Tucson, AZ 85734 • Street Address: 6730 S. Tucson Blvd., Tucson, AZ 85706 • Tel: (520) 746-1111 • Twx: 910-952-1111
Internet: <http://www.burr-brown.com/> • FAXLine: (800) 548-6133 (US/Canada Only) • Cable: BBRCORP • Telex: 066-6491 • FAX: (520) 889-1510 • Immediate Product Info: (800) 548-6132

SPECIFICATIONS

ELECTRICAL

At $T_A = -40^{\circ}\text{C}$ to $+85^{\circ}\text{C}$, $f_S = 800\text{kHz}$, $+V_{\text{DIG}} = +V_{\text{ANA}} = +5\text{V}$, $-V_{\text{ANA}} = -5\text{V}$, using internal reference and the 50Ω input resistor shown in Figure 4b, unless otherwise specified.

PARAMETER	CONDITIONS	ADS7810U			ADS7810UB			UNITS
		MIN	TYP	MAX	MIN	TYP	MAX	
RESOLUTION				12			*	Bits
ANALOG INPUT								
Voltage Range			± 10			*		V
Impedance			3.1			*		$k\Omega$
Capacitance			5			*		pF
THROUGHPUT SPEED								
Conversion Cycle	$t_3 + t_4$		1020			*		ns
Complete Cycle	Acquire & Convert			1250			*	ns
Throughput Rate		800			*			kHz
DC ACCURACY								
Integral Linearity Error				± 1			± 0.75	LSB ⁽¹⁾
Differential Linearity Error				± 1			*	LSB
No Missing Codes			Guaranteed			*		
Transition Noise ⁽²⁾			0.1			*		LSB
Full Scale Error ^(3, 4)				± 0.5			± 0.25	%
Full Scale Error Drift			± 12			*		ppm/ $^{\circ}\text{C}$
Full Scale Error ^(3, 4)	Ext. 2.5000V Ref			± 0.5			*	%
Full Scale Error Drift	Ext. 2.5000V Ref		± 12			*		ppm/ $^{\circ}\text{C}$
Bipolar Zero Error ⁽³⁾				± 8			± 4	LSB
Bipolar Zero Error Drift			± 2			*		ppm/ $^{\circ}\text{C}$
Power Supply Sensitivity ($+V_{\text{DIG}} = +V_{\text{ANA}} = V_{\text{D}}$)	$+4.75\text{V} < V_{\text{D}} < +5.25\text{V}$ $-5.25\text{V} < -V_{\text{ANA}} < -4.75\text{V}$			± 5 ± 0.5			*	LSB
				± 0.5			*	LSB
AC ACCURACY								
Spurious-Free Dynamic Range	$f_{\text{IN}} = 250\text{kHz}$	74	82		77	84		dB ⁽⁵⁾
Total Harmonic Distortion	$f_{\text{IN}} = 250\text{kHz}$		-80	-74		-82	-77	dB
Signal-to-(Noise+Distortion)	$f_{\text{IN}} = 250\text{kHz}$	67	71		69	*		dB
Signal-to-Noise	$f_{\text{IN}} = 250\text{kHz}$	68	71		70	*		dB
Usable Bandwidth ⁽⁶⁾			1.5			*		MHz
SAMPLING DYNAMICS								
Aperture Delay			20			*		ns
Aperture Jitter			10			*		ps
Transient Response	FS Step		200			*		ns
Overvoltage Recovery ⁽⁷⁾			250			*		ns
REFERENCE								
Internal Reference Voltage		2.48	2.5	2.52	*	*	*	V
Internal Reference DC Source Current (External load should be static)			100			*		μA
Internal Reference Drift			8					ppm/ $^{\circ}\text{C}$
External Reference Voltage Range For Specified Linearity		2.3	2.5	2.7	*	*	*	V
External Reference Current Drain	Ext. 2.5000V Ref			100			*	μA
DIGITAL INPUTS								
Logic Levels								
V_{IL}		-0.3		+0.8	*		*	V
V_{IH}		+2.4		$V_{\text{D}} + 0.3$	*		*	V
I_{IL}	$V_{\text{IL}} = 0\text{V}$			± 10			*	μA
I_{IH}	$V_{\text{IH}} = 5\text{V}$			± 10			*	μA
DIGITAL OUTPUTS								
Data Format								
Data Coding								
V_{OL}	$I_{\text{SINK}} = 1.6\text{mA}$							V
V_{OH}	$I_{\text{SOURCE}} = 500\mu\text{A}$							V
Leakage Current	High-Z State, $V_{\text{OUT}} = 0\text{V}$ to V_{DIG} High-Z State	+2.8		± 5		*	*	μA
Output Capacitance				15			15	pF
DIGITAL TIMING								
Bus Access Time				62			*	ns
Bus Relinquish Time				83			*	ns

The information provided herein is believed to be reliable; however, BURR-BROWN assumes no responsibility for inaccuracies or omissions. BURR-BROWN assumes no responsibility for the use of this information, and all use of such information shall be entirely at the user's own risk. Prices and specifications are subject to change without notice. No patent rights or licenses to any of the circuits described herein are implied or granted to any third party. BURR-BROWN does not authorize or warrant any BURR-BROWN product for use in life support devices and/or systems.

SPECIFICATIONS (CONT)

ELECTRICAL

At $T_A = -40^\circ\text{C}$ to $+85^\circ\text{C}$, $f_S = 800\text{kHz}$, $+V_{\text{DIG}} = +V_{\text{ANA}} = +5\text{V}$, $-V_{\text{ANA}} = -5\text{V}$, using internal reference and the 50Ω input resistor shown in Figure 4b, unless otherwise specified.

PARAMETER	CONDITIONS	ADS7810U			ADS7810UB			UNITS	
		MIN	TYP	MAX	MIN	TYP	MAX		
POWER SUPPLIES Specified Performance $+V_{\text{DIG}} = +V_{\text{ANA}}$ $-V_{\text{ANA}}$ $+I_{\text{DIG}}$ $+I_{\text{ANA}}$ $-I_{\text{ANA}}$ Derated Performance $+V_{\text{DIG}} = +V_{\text{ANA}}$ $-V_{\text{ANA}}$ Power Dissipation $f_S = 800\text{kHz}$		+4.75	+5	+5.25	*	*	*	V	
		-5.25	-5	-4.75	*	*	*	V	
			+16			*		mA	
			+16			*		mA	
				-13		*		mA	
			+4.5	+5	+5.5	*	*	*	V
			-5.5	-5	-4.5	*	*	*	V
			225	275			*	mW	
TEMPERATURE RANGE Specified Performance Derated Performance Storage Thermal Resistance (θ_{JA}) Plastic DIP SOIC		-40		+85	*		*	$^\circ\text{C}$	
		-55		+125				$^\circ\text{C}$	
		-65		+150	*		*	$^\circ\text{C}$	
			75			*		$^\circ\text{C/W}$	
			75			*		$^\circ\text{C/W}$	

* Specification same as ADS7810U.

NOTES: (1) LSB means Least Significant Bit. For the 12-bit, $\pm 10\text{V}$ input ADS7810, one LSB is 4.88mV. (2) Typical rms noise at worst case transitions and temperatures. (3) Measured with 50Ω in series with analog input. Adjustable to zero with external potentiometer. (4) Full scale error is the worst case of $-$ Full Scale or $+$ Full Scale untrimmed deviation from ideal first and last code transitions, divided by the transition voltage (not divided by the full-scale range) and includes the effect of offset error. (5) All specifications in dB are referred to a full-scale $\pm 10\text{V}$ input. (6) Usable Bandwidth defined as Full-Scale input frequency at which Signal-to-(Noise+Distortion) degrades to 60dB, or 10 bits of accuracy. (7) Recovers to specified performance after $2 \times \text{FS}$ input over voltage.

ABSOLUTE MAXIMUM RATINGS

Analog Inputs: V_{IN}	$\pm 25\text{V}$
REF	$+V_{\text{ANA}} + 0.3\text{V}$ to AGND2 -0.3V
CAP	Indefinite Short to AGND2 Momentary Short to $+V_{\text{ANA}}$
Ground Voltage Differences: DGND, AGND1, AGND2	$\pm 0.3\text{V}$
$+V_{\text{ANA}}$	$+7\text{V}$
$+V_{\text{DIG}}$ to $+V_{\text{ANA}}$	$+0.3\text{V}$
$+V_{\text{DIG}}$	7V
$-V_{\text{ANA}}$	-7V
Digital Inputs	-0.3V to $+V_{\text{DIG}} + 0.3\text{V}$
Maximum Junction Temperature	$+165^\circ\text{C}$
Internal Power Dissipation	825mW
Lead Temperature (soldering, 10s)	$+300^\circ\text{C}$



ELECTROSTATIC DISCHARGE SENSITIVITY

This integrated circuit can be damaged by ESD. Burr-Brown recommends that all integrated circuits be handled with appropriate precautions. Failure to observe proper handling and installation procedures can cause damage.

ESD damage can range from subtle performance degradation to complete device failure. Precision integrated circuits may be more susceptible to damage because very small parametric changes could cause the device not to meet its published specifications.

ORDERING/PACKAGE INFORMATION

PRODUCT	MAXIMUM INTEGRAL LINEARITY ERROR (LSB)	MINIMUM SIGNAL-TO-(NOISE + DISTORTION) RATIO (dB)	SPECIFICATION TEMPERATURE RANGE	PACKAGE	PACKAGE DRAWING NUMBER ⁽¹⁾
ADS7810U	± 1	67	-40°C to $+85^\circ\text{C}$	28-Pin SOIC	217
ADS7810UB	± 0.75	69	-40°C to $+85^\circ\text{C}$	28-Pin SOIC	217

NOTE: (1) For detailed drawing and dimension table, please see end of data sheet, or Appendix C of Burr-Brown IC Data Book.

PIN ASSIGNMENTS

PIN #	NAME	DIGITAL I/O	DESCRIPTION
1	V _{IN}		Analog Input. Connect via 50Ω to analog input. Full-scale input range is ±10V.
2	AGND1		Analog Ground. Used internally as ground reference point. Minimal current flow.
3	REF		Reference Input/Output. Outputs internal reference of +2.5V nominal. Can also be driven by external system reference. In both cases, decouple to ground with a 0.1μF ceramic capacitor.
4	CAP		Reference Buffer Output. 10μF tantalum capacitor to ground. Nominally +2V.
5	AGND2		Analog Ground.
6	D11 (MSB)	O	Data Bit 11. Most Significant Bit (MSB) of conversion results. Hi-Z state when \overline{CS} is HIGH, or when R/\overline{C} is LOW, or when a conversion is in progress.
7	D10	O	Data Bit 10. Hi-Z state when \overline{CS} is HIGH, or when R/\overline{C} is LOW, or when a conversion is in progress.
8	D9	O	Data Bit 9. Hi-Z state when \overline{CS} is HIGH, or when R/\overline{C} is LOW, or when a conversion is in progress.
9	D8	O	Data Bit 8. Hi-Z state when \overline{CS} is HIGH, or when R/\overline{C} is LOW, or when a conversion is in progress.
10	D7	O	Data Bit 7. Hi-Z state when \overline{CS} is HIGH, or when R/\overline{C} is LOW, or when a conversion is in progress.
11	D6	O	Data Bit 6. Hi-Z state when \overline{CS} is HIGH, or when R/\overline{C} is LOW, or when a conversion is in progress.
12	D5	O	Data Bit 5. Hi-Z state when \overline{CS} is HIGH, or when R/\overline{C} is LOW, or when a conversion is in progress.
13	D4	O	Data Bit 4. Hi-Z state when \overline{CS} is HIGH, or when R/\overline{C} is LOW, or when a conversion is in progress.
14	DGND		Digital Ground.
15	D3	O	Data Bit 3. Hi-Z state when \overline{CS} is HIGH, or when R/\overline{C} is LOW, or when a conversion is in progress.
16	D2	O	Data Bit 2. Hi-Z state when \overline{CS} is HIGH, or when R/\overline{C} is LOW, or when a conversion is in progress.
17	D1	O	Data Bit 1. Hi-Z state when \overline{CS} is HIGH, or when R/\overline{C} is LOW, or when a conversion is in progress.
18	D0 (LSB)	O	Data Bit 0. Least Significant Bit (LSB) of conversion results. Hi-Z state when \overline{CS} is HIGH, or when R/\overline{C} is LOW, or when a conversion is in progress.
19			Not internally connected.
20	+V _{ANA}		Analog Positive Supply Input. Nominally +5V. Connect directly to pins 21, 27 and 28.
21	+V _{DIG}		Digital Supply Input. Nominally +5V. Connect directly to pins 20, 27 and 28.
22	DGND		Digital ground.
23	R/ \overline{C}	I	Read/Convert Input. With \overline{CS} LOW, a falling edge on R/\overline{C} puts the internal sample/hold into the hold state and starts a conversion. With \overline{CS} LOW and no conversion in progress, a rising edge on R/\overline{C} enables the output data bits.
24	\overline{CS}	I	Chip Select. With R/\overline{C} LOW, a falling edge on \overline{CS} will initiate a conversion. With R/\overline{C} HIGH and no conversion in progress, a falling edge on \overline{CS} will enable the output data bits.
25	\overline{BUSY}	O	Busy Output. Falls when a conversion is started, and remains LOW until the conversion is completed and the data is latched into the output register. With \overline{CS} LOW and R/\overline{C} HIGH, output data will be valid when \overline{BUSY} rises, so that the rising edge can be used to latch the data.
26	-V _{ANA}		Analog Negative Supply Input. Nominally -5V. Decouple to ground with 0.1μF ceramic and 10μF tantalum capacitors.
27	+V _{DIG}		Digital Supply Input. Nominally +5V. Connect directly to pins 20, 21 and 28.
28	+V _{ANA}		Analog Positive Supply Input. Nominally +5V. Connect directly to pins 20, 21 and 27, and decouple to ground with 0.1μF ceramic and 10μF tantalum capacitors.

PIN CONFIGURATION

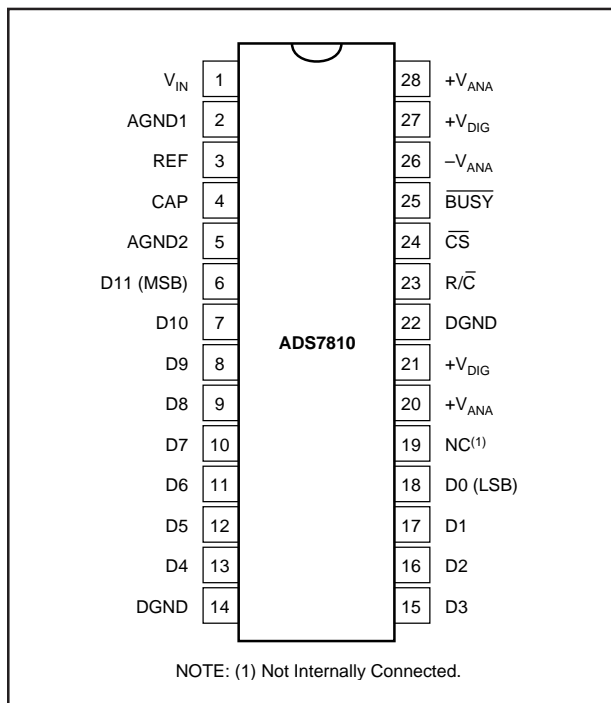

TYPICAL PERFORMANCE CURVES

T = +25°C, $f_s = 800\text{kHz}$, $+V_{\text{DIG}} = +V_{\text{ANA}} = +5\text{V}$, $-V_{\text{ANA}} = -5\text{V}$, using internal reference and the input 50Ω resistors as shown in Figure 4b, unless otherwise specified.

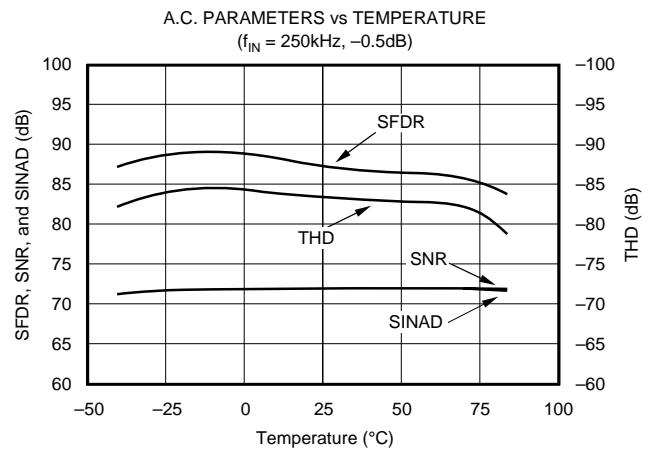
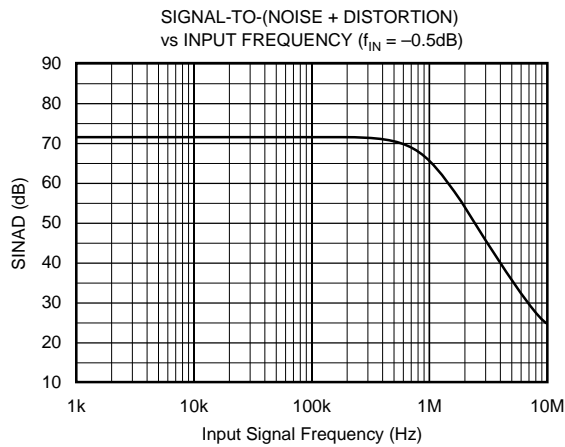
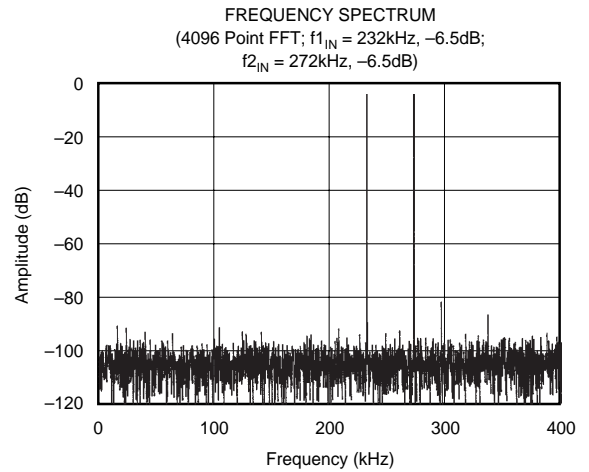
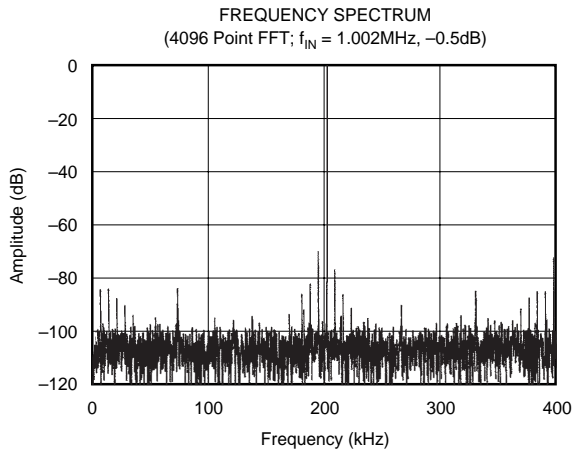
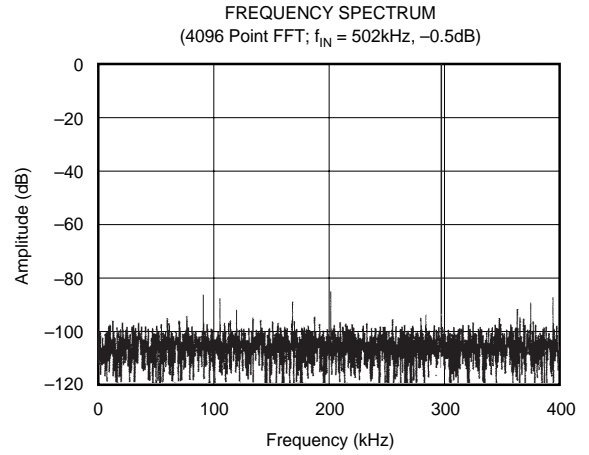
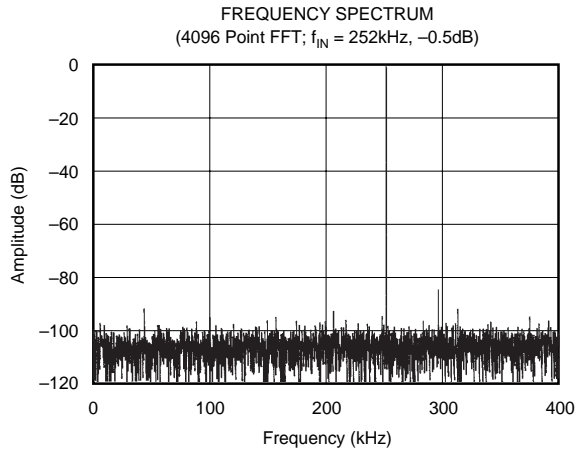

TYPICAL PERFORMANCE CURVES (CONT)

T = +25°C, $f_s = 800\text{kHz}$, $V_{DIG} = +V_{ANA} = +5\text{V}$, $-V_{ANA} = -5\text{V}$, using internal reference and the 50Ω input resistors as shown in Figure 4b, unless otherwise specified.

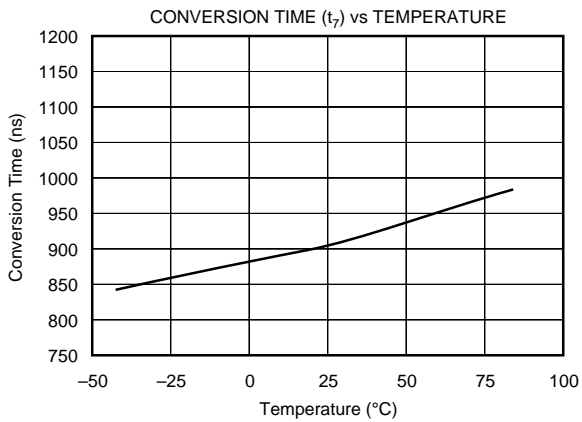
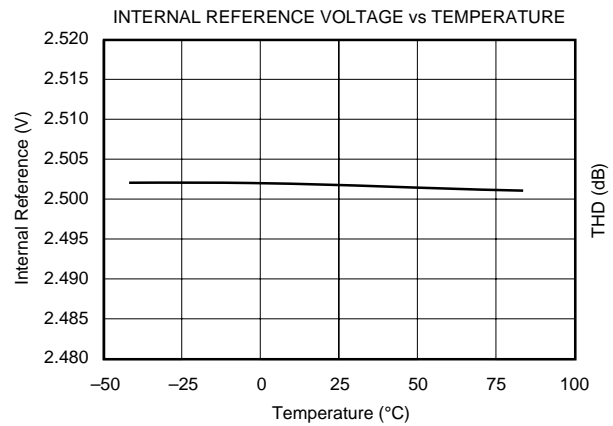
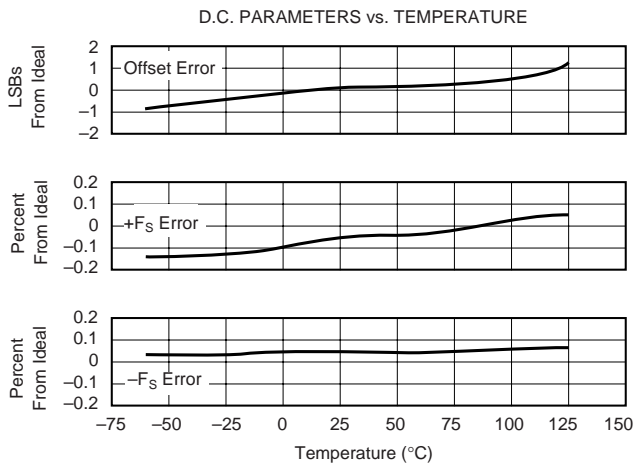
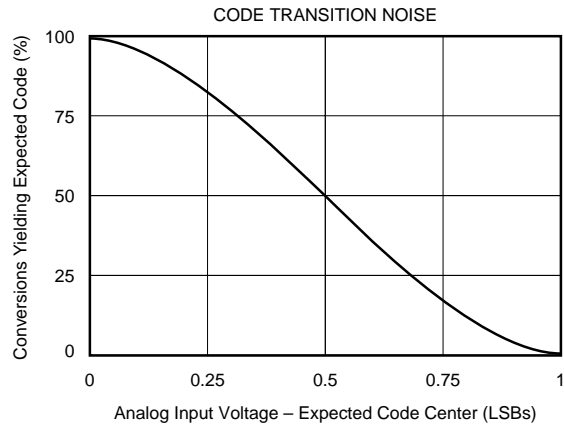
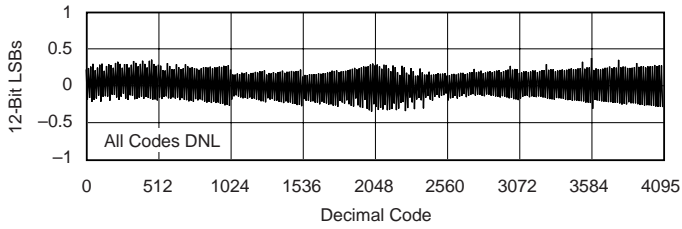
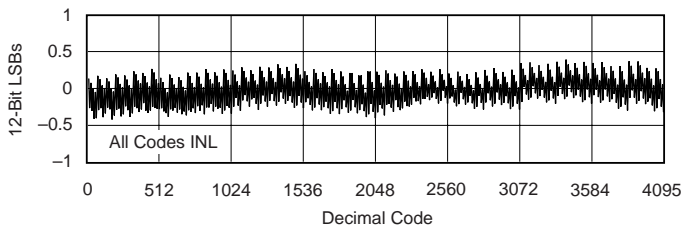

BASIC OPERATION

Figure 1 shows a basic circuit to operate the ADS7810. Taking $\overline{R/C}$ (pin 23) LOW for a minimum of 40ns will initiate a conversion. \overline{BUSY} (pin 25) will go LOW and stay LOW until the conversion is completed and the output registers are updated. Data will be output in Binary Two's Complement with the MSB on D11 (pin 6). \overline{BUSY} going HIGH can be used to latch the data. All convert commands will be ignored while \overline{BUSY} is LOW.

The ADS7810 will begin tracking the input signal at the end of the conversion. Allowing 1.25 μ s between convert commands assures accurate acquisition of a new signal.

\overline{CS}	$\overline{R/C}$	\overline{BUSY}	OPERATION
1	X	X	None. Databus in Hi-Z state.
↓	0	1	Initiates conversion. Databus remains in Hi-Z state.
0	↓	1	Initiates conversion. Databus enters Hi-Z state.
0	1	↑	Conversion completed. Valid data from the most recent conversion on the databus.
↓	1	1	Enables databus with valid data from the most recent conversion.
↓	1	0	Conversion in progress. Databus in Hi-Z state, enabled when the conversion is completed
0	↑	0	Conversion in progress. Databus in Hi-Z state, enabled when the conversion is completed
0	0	↑	Conversion completed. Valid data from the most recent conversion in the output register, but output pins D11-D0 are tri-stated.
X	X	0	New convert commands ignored. Conversion in progress.

Table I. Control Line Functions for 'read' and 'convert'.

STARTING A CONVERSION

The combination of \overline{CS} (pin 24) and $\overline{R/C}$ (pin 23) LOW for a minimum of 40ns puts the sample/hold of the ADS7810 in the hold state and starts a conversion. \overline{BUSY} (pin 25) will go LOW and stay LOW until the conversion is completed and the internal output register has been updated. All new convert commands during \overline{BUSY} LOW will be ignored.

The ADS7810 will begin tracking the input signal at the end of the conversion. Allowing 1.25 μ s between convert commands assures accurate acquisition of a new signal. Refer to Table I for a summary of \overline{CS} , $\overline{R/C}$, and \overline{BUSY} states and Figures 2 and 3 for timing parameters.

\overline{CS} and $\overline{R/C}$ are internally OR'd and level triggered. There is not a requirement which input goes LOW first when initiating a conversion. If it is critical that \overline{CS} or $\overline{R/C}$ initiate the conversion, be sure the less critical input is LOW at least 10ns prior to the initiating input.

DESCRIPTION	ANALOG VALUE	DIGITAL OUTPUT	
Full Scale Range	$\pm 10V$	BINARY TWO'S COMPLEMENT	
Least Significant Bit (LSB)	4.88mV	BINARY CODE	HEX CODE
+Full Scale (10V - 1LSB)	9.995V	0111 1111 1111	7FF
Midscale	0V	0000 0000 0000	000
One LSB below Midscale	-4.88mV	1111 1111 1111	FFF
-Full Scale	-10V	1000 0000 0000	800

TABLE II. Ideal Input Voltages and Output Codes.

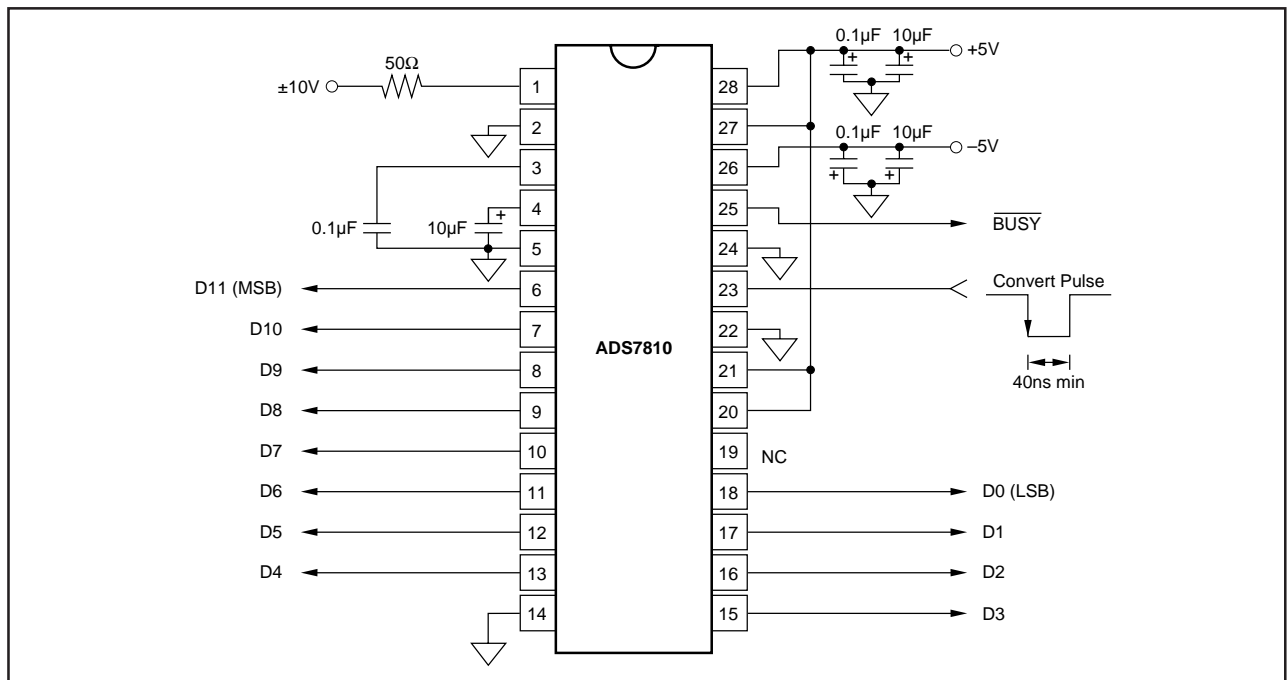

FIGURE 1. Basic Operation

To reduce the number of control pins, \overline{CS} can be tied LOW using R/\overline{C} to control the read and convert modes. Note that the parallel output will be active whenever R/\overline{C} is HIGH and no conversion is in progress. See the Reading Data section and refer to Table I for control line functions for ‘read’ and ‘convert’ modes.

READING DATA

The ADS7810 outputs full parallel data in Binary Two’s Complement data format. The parallel output will be active when R/\overline{C} (pin 23) is HIGH, \overline{CS} (pin 24) is LOW, and no conversion is in progress. Any other combination will tristate the parallel output. Valid conversion data can be read in a full parallel, 12-bit word on D11-D0 (pins 6-13 and 15-18). Refer to Table II for ideal output codes.

After the conversion is completed and the output registers have been updated, $BUSY$ (pin 25) will go HIGH. Valid data from the most recent conversion will be available on D11-D0 (pins 6-13 and 15-18). $BUSY$ going HIGH can be used to latch the data. Refer to Table III and Figures 2 and 3.

Note: For the best performance, the external data bus connected to D11-D0 should not be active during a conversion. The switching noise of the external asynchronous data signals can cause digital feedthrough degrading the converter’s performance.

The number of control lines can be reduced by tying \overline{CS} LOW while using R/\overline{C} to initiate conversions and activate the output mode of the converter. See Figure 2.

INPUT RANGES

The ADS7810 offers a standard $\pm 10V$ input range. Figures 4a and 4b show the necessary circuit connections for the ADS7810 with and without external trim. Offset and full scale error⁽¹⁾ specifications are tested and guaranteed with the 50Ω resistor shown in Figure 4b. This external resistor makes it possible to trim the offset $\pm 50mV$ using a trim pot or trim DAC. This resistor may be left out if the offset and gain errors will be corrected in software or if they are negligible in regards to the particular application. See the **Calibration** section of the data sheet for details.

The nominal input impedance of $3.125k\Omega$ results from the combination of the internal resistor network shown on the front page of the product data sheet and external 50Ω resistor. The input resistor divider network provides inherent overvoltage protection guaranteed to at least $\pm 25V$. The 50Ω , 1% resistor does not compromise the accuracy or drift of the converter. It has little influence relative to the internal resistors, and tighter tolerances are not required.

Note: The values shown for the internal resistors are for reference only. The exact values can vary by $\pm 30\%$. This is true of all resistors internal to the ADS7810. Each resistive divider is trimmed so that the proper division is achieved.

NOTE: (1) Full scale error includes offset and gain errors measured at both +FS and –FS.

SYMBOL	DESCRIPTION	MIN	TYP	MAX	UNITS
t_1	Convert Pulse Width	40			ns
t_2	Data Valid Delay After R/\overline{C} LOW		955	1095	ns
t_3	\overline{BUSY} Delay From R/\overline{C} LOW		70	125	ns
t_4	\overline{BUSY} LOW		950	1080	ns
t_5	\overline{BUSY} Delay After End of Conversion		90		ns
t_6	Aperture Delay		20		ns
t_7	Conversion Time		910	1020	ns
t_8	Acquisition Time		200	230	ns
t_7 & t_8	Throughput Time		1110	1250	ns
t_9	Bus Relinquish Time	10	50	83	ns
t_{10}	\overline{BUSY} Delay After Data Valid	20	65	120	ns
t_{11}	R/\overline{C} to \overline{CS} Setup Time	10			ns
t_{12}	Time Between Conversions	1250			ns
t_{13}	Bus Access Time	10	25	62	ns

TABLE III. Timing Specifications (T_{MIN} to T_{MAX}).

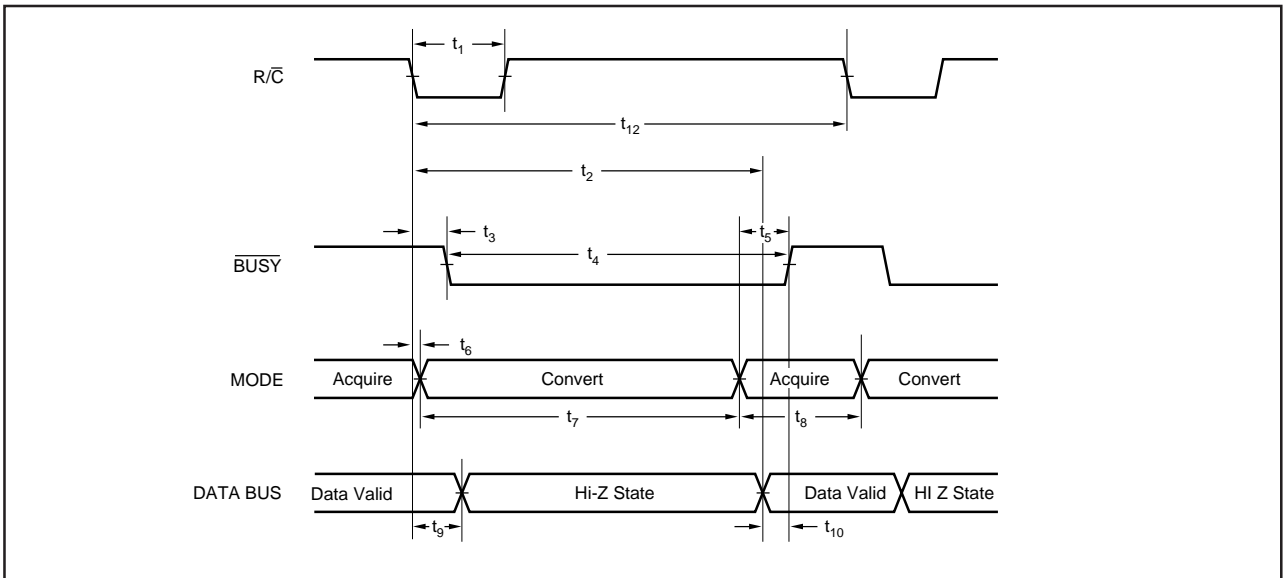

FIGURE 2. Conversion Timing with Outputs Enabled After Conversion (\overline{CS} Tied Low).

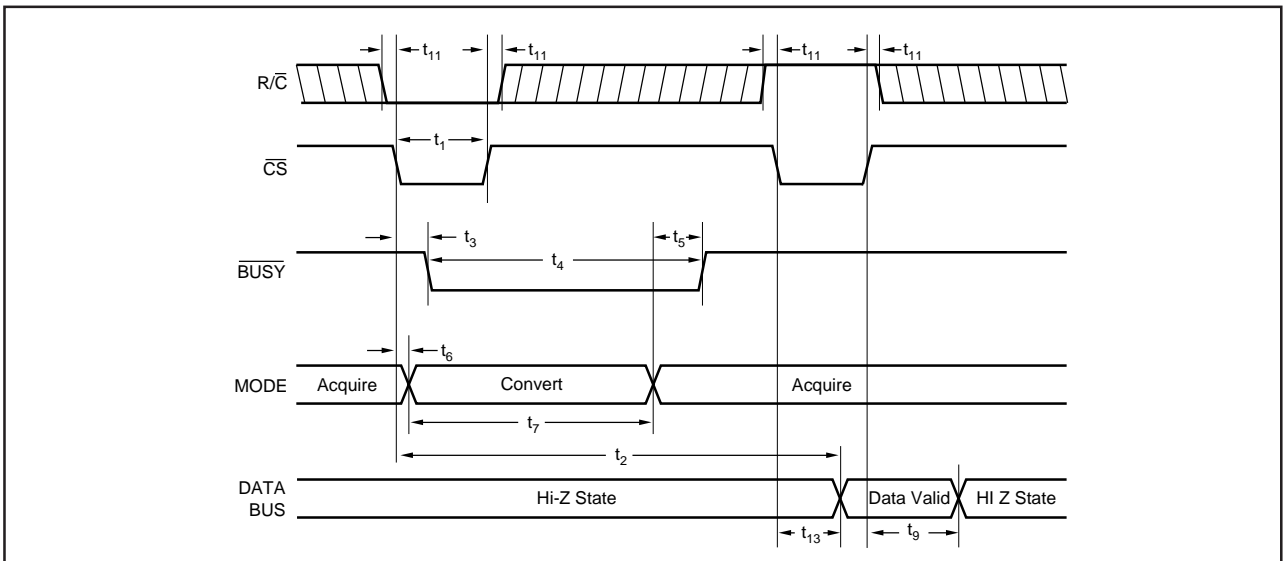

FIGURE 3. Using \overline{CS} to Control Conversion and Read Timing.

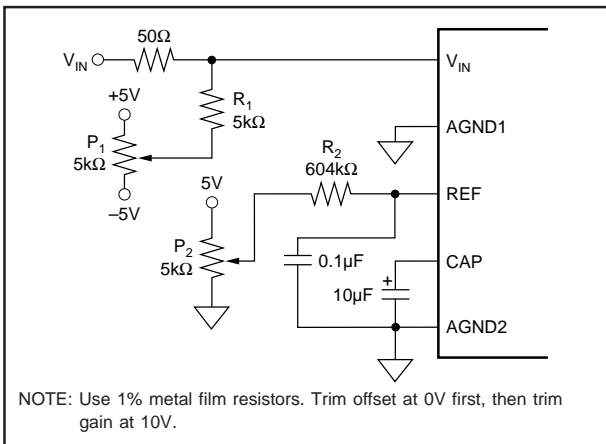

FIGURE 4a. Circuit Diagram With External Hardware Trim.

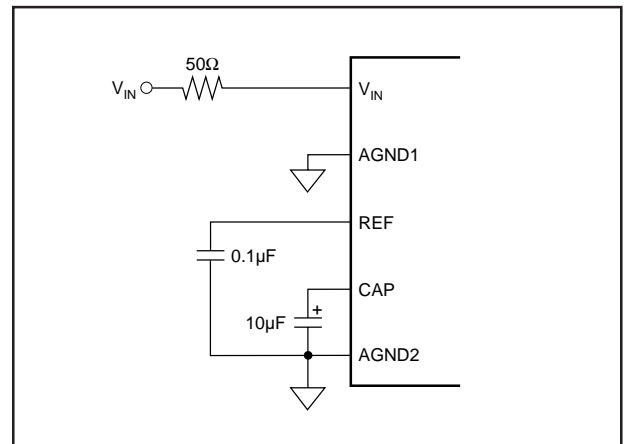

FIGURE 4b. Circuit Diagram Without External Hardware Trim.

CALIBRATION

The ADS7810 can be trimmed in hardware or software. The offset should be trimmed before the gain since the offset directly affects the gain.

Hardware Calibration

To calibrate the offset and gain of the ADS7810, install the proper resistors and potentiometers as shown in Figure 4a. The calibration range is $\pm 50\text{mV}$ for bipolar zero and $\pm 120\text{mV}$ for full scale.

Potentiometer P_1 and resistor R_1 form the offset adjust circuit and P_2 and R_2 the gain adjust circuit. The exact values are not critical. R_1 and R_2 should not be made any larger than the value shown. They can easily be made smaller to provide increased adjustment range. Reducing these below 15% of the indicated values could begin to adversely affect the operation of the converter.

P_1 and P_2 can also be made larger to reduce power dissipation. However, larger resistances will push the useful adjustment range to the edges of the potentiometer. P_1 should probably not exceed $20\text{k}\Omega$ and P_2 $100\text{k}\Omega$ in order to maintain reasonable sensitivity.

Software Calibration

To calibrate the offset and gain of the ADS7810, no external resistors are required. See the **No Calibration** section for details on the effects of the external resistor.

No Calibration

See Figure 4b for circuit connections. Note that the actual voltage dropped across the 50Ω resistor is nearly two orders of magnitude lower than the voltage dropped across the internal resistor divider network. This should be taken into consideration when choosing the accuracy and drift specifications of the external resistors. In most applications, 1% metal-film resistors will be sufficient.

The external 50Ω resistor shown in Figure 4b may not be necessary in some applications. This resistor provides trim capability for the offset and compensates for a slight gain adjustment internal to the ADS7810. Not using the 50Ω resistor will cause a small gain error but will have no effect on the inherent offset error. Figure 5 shows typical transfer function characteristics with and without the 50Ω resistor in the circuit.

REFERENCE

The ADS7810 can operate with its internal 2.5V reference or an external reference. By applying an external reference to pin 3, the internal reference can be bypassed. The reference voltage at REF is buffered internally and output on CAP (pin 4).

REF

REF (pin 3) is an input for an external reference or the output for the internal 2.5V reference. A $0.1\mu\text{F}$ capacitor should be connected as close to the REF pin as possible. The capacitor and the output resistance of REF create a low pass filter to band limit noise on the reference. Using a smaller value capacitor will introduce more noise to the reference degrading the SNR and SINAD. The internal reference should not be used to sink or source currents greater than $100\mu\text{A}$. In addition, all external loads should be static.

The range for the external reference is 2.3V to 2.7V and determines the actual LSB size. Increasing the reference voltage will increase the full scale range and the LSB size of the converter which can improve the SNR.

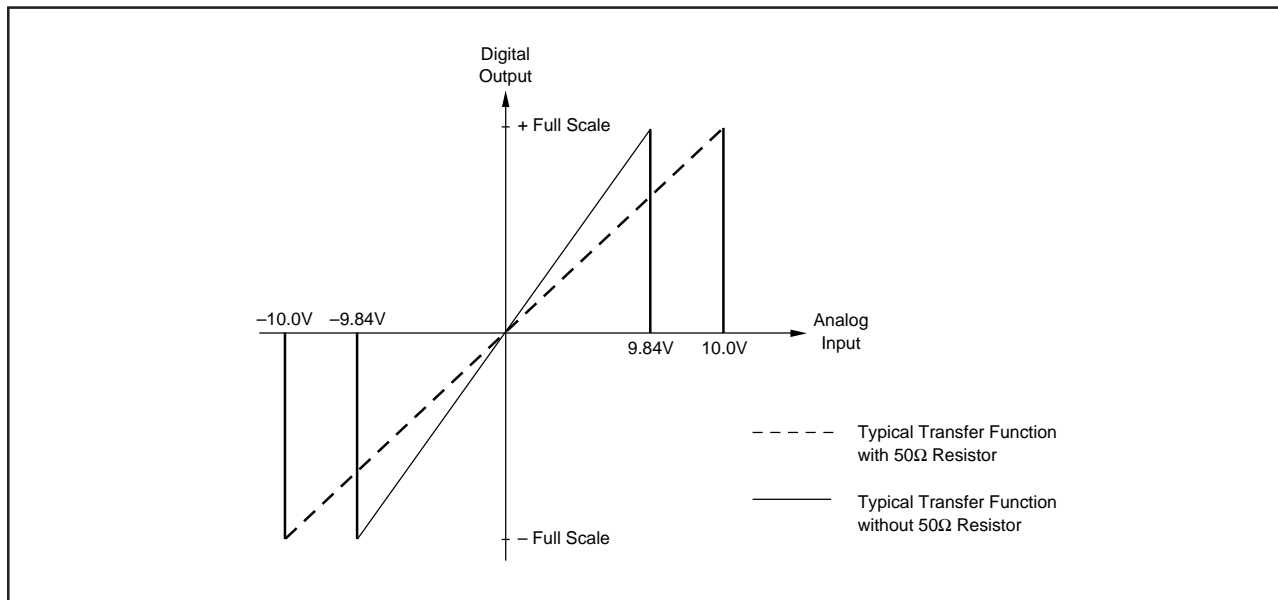

FIGURE 5. Comparison of the ADS7810 Transfer Function With and Without the 50Ω Series Resistor on V_{IN} .

CAP

CAP (pin 4) is the output of the internal reference buffer. A 10 μ F tantalum capacitor should be placed as close to the CAP as possible to provide optimum switching currents for the CDAC throughout the conversion cycle and compensation for the output of the buffer. Using a capacitor any smaller than 1 μ F can cause the output buffer to oscillate and may not have sufficient charge for the CDAC. Capacitor values larger than 10 μ F will have little effect on improving performance. The voltage on the CAP pin is approximately 2V when using the internal reference, or 80% of an externally supplied reference.

LAYOUT

POWER

The ADS7810 uses the majority of its power for analog and static circuitry, and it should be considered as an analog component. For optimum performance, tie the analog and digital +5V power pins to the same +5V power supply and tie the analog and digital grounds together.

For best performance, the \pm 5V supplies can be produced from whatever analog supply is used for the rest of the analog signal conditioning. If \pm 12V or \pm 15V supplies are present, simple regulators can be used. The +5V power for the A/D should be separate from the +5V used for the system's digital logic. Connecting +V_{DIG} (pin 27) directly to a digital supply can reduce converter performance due to switching noise from the digital logic.

Although it is not suggested, if the digital supply must be used to power the converter, be sure to properly filter the supply. Either using a filtered digital supply or a regulated analog supply, both V_{DIG} and V_{ANA} should be tied to the same +5V source.

GROUNDING

Three ground pins are present on the ADS7810. DGND (pin 22) is the digital supply ground. AGND2 (pin 5) is the analog supply ground. AGND1 (pin 2) is the ground which all analog signals internal to the A/D are referenced. AGND1 is more susceptible to current induced voltage drops and must have the path of least resistance back to the power supply.

All the ground pins of the ADS should be tied to the analog ground plane, separated from the system's digital logic ground, to achieve optimum performance. Both analog and digital ground planes should be tied to the "system" ground as near to the power supplies as possible. This helps to prevent dynamic digital ground currents from modulating the analog ground through a common impedance to power ground.

SIGNAL CONDITIONING

The FET switches used for the sample hold on many CMOS A/D converters release a significant amount of charge injection which can cause the driving op amp to oscillate. The resistive front end of the ADS7810 attenuates this charge and reduces its magnitude significantly—reducing the burden on the external input amplifier or buffer.

However, keep in mind that maintaining signal integrity at voltage swings of \pm 10V and frequencies of several hundred kilohertz is extremely challenging. In addition, the external input amplifier must drive the ADS7810 mainly during its sample period—roughly 200ns. This will require a high-speed, precision amplifier which can swing to greater than \pm 10V.

For signals where the predominant frequencies are below 200kHz, the OPA671 operational amplifier should be adequate for most applications. In some cases or where input frequencies are higher, a composite configuration of the OPA671 and BUF634 (in its wide bandwidth mode) may be the best choice. See the BUF634 data sheet for more information.

The resistive front end of the ADS7810 also provides a guaranteed \pm 25V over voltage protection. In most cases, this eliminates the need for external input protection circuitry.

INTERMEDIATE LATCHES

The ADS7810 does have tri-state outputs for the parallel port, but intermediate latches should be used if the bus will be active during conversions. If the bus is not active during conversions, the tri-state outputs can be used to isolate the A/D from other peripherals on the same bus.

Intermediate latches are beneficial on any monolithic A/D converter. The ADS7810 has an internal LSB size of 610 μ V. Transients from fast switching signals on the parallel port, even when the A/D is tri-stated, can be coupled through the substrate to the analog circuitry causing degradation of converter performance.

PACKAGING INFORMATION

Orderable Device	Status ⁽¹⁾	Package Type	Package Drawing	Pins	Package Qty	Eco Plan ⁽²⁾	Lead/Ball Finish	MSL Peak Temp ⁽³⁾
ADS7810U	ACTIVE	SOIC	DW	28	28	None	CU SNPB	Level-3-220C-168 HR
ADS7810U/1K	ACTIVE	SOIC	DW	28	1000	None	CU SNPB	Level-3-220C-168 HR
ADS7810UB	ACTIVE	SOIC	DW	28	28	None	CU SNPB	Level-3-220C-168 HR
ADS7810UB/1K	ACTIVE	SOIC	DW	28	1000	None	CU SNPB	Level-3-220C-168 HR

⁽¹⁾ The marketing status values are defined as follows:

ACTIVE: Product device recommended for new designs.

LIFEBUY: TI has announced that the device will be discontinued, and a lifetime-buy period is in effect.

NRND: Not recommended for new designs. Device is in production to support existing customers, but TI does not recommend using this part in a new design.

PREVIEW: Device has been announced but is not in production. Samples may or may not be available.

OBSOLETE: TI has discontinued the production of the device.

⁽²⁾ Eco Plan - May not be currently available - please check <http://www.ti.com/productcontent> for the latest availability information and additional product content details.

None: Not yet available Lead (Pb-Free).

Pb-Free (RoHS): TI's terms "Lead-Free" or "Pb-Free" mean semiconductor products that are compatible with the current RoHS requirements for all 6 substances, including the requirement that lead not exceed 0.1% by weight in homogeneous materials. Where designed to be soldered at high temperatures, TI Pb-Free products are suitable for use in specified lead-free processes.

Green (RoHS & no Sb/Br): TI defines "Green" to mean "Pb-Free" and in addition, uses package materials that do not contain halogens, including bromine (Br) or antimony (Sb) above 0.1% of total product weight.

⁽³⁾ MSL, Peak Temp. -- The Moisture Sensitivity Level rating according to the JEDEC industry standard classifications, and peak solder temperature.

Important Information and Disclaimer:The information provided on this page represents TI's knowledge and belief as of the date that it is provided. TI bases its knowledge and belief on information provided by third parties, and makes no representation or warranty as to the accuracy of such information. Efforts are underway to better integrate information from third parties. TI has taken and continues to take reasonable steps to provide representative and accurate information but may not have conducted destructive testing or chemical analysis on incoming materials and chemicals. TI and TI suppliers consider certain information to be proprietary, and thus CAS numbers and other limited information may not be available for release.

In no event shall TI's liability arising out of such information exceed the total purchase price of the TI part(s) at issue in this document sold by TI to Customer on an annual basis.

IMPORTANT NOTICE

Texas Instruments Incorporated and its subsidiaries (TI) reserve the right to make corrections, modifications, enhancements, improvements, and other changes to its products and services at any time and to discontinue any product or service without notice. Customers should obtain the latest relevant information before placing orders and should verify that such information is current and complete. All products are sold subject to TI's terms and conditions of sale supplied at the time of order acknowledgment.

TI warrants performance of its hardware products to the specifications applicable at the time of sale in accordance with TI's standard warranty. Testing and other quality control techniques are used to the extent TI deems necessary to support this warranty. Except where mandated by government requirements, testing of all parameters of each product is not necessarily performed.

TI assumes no liability for applications assistance or customer product design. Customers are responsible for their products and applications using TI components. To minimize the risks associated with customer products and applications, customers should provide adequate design and operating safeguards.

TI does not warrant or represent that any license, either express or implied, is granted under any TI patent right, copyright, mask work right, or other TI intellectual property right relating to any combination, machine, or process in which TI products or services are used. Information published by TI regarding third-party products or services does not constitute a license from TI to use such products or services or a warranty or endorsement thereof. Use of such information may require a license from a third party under the patents or other intellectual property of the third party, or a license from TI under the patents or other intellectual property of TI.

Reproduction of information in TI data books or data sheets is permissible only if reproduction is without alteration and is accompanied by all associated warranties, conditions, limitations, and notices. Reproduction of this information with alteration is an unfair and deceptive business practice. TI is not responsible or liable for such altered documentation.

Resale of TI products or services with statements different from or beyond the parameters stated by TI for that product or service voids all express and any implied warranties for the associated TI product or service and is an unfair and deceptive business practice. TI is not responsible or liable for any such statements.

Following are URLs where you can obtain information on other Texas Instruments products and application solutions:

Products		Applications	
Amplifiers	amplifier.ti.com	Audio	www.ti.com/audio
Data Converters	dataconverter.ti.com	Automotive	www.ti.com/automotive
DSP	dsp.ti.com	Broadband	www.ti.com/broadband
Interface	interface.ti.com	Digital Control	www.ti.com/digitalcontrol
Logic	logic.ti.com	Military	www.ti.com/military
Power Mgmt	power.ti.com	Optical Networking	www.ti.com/opticalnetwork
Microcontrollers	microcontroller.ti.com	Security	www.ti.com/security
		Telephony	www.ti.com/telephony
		Video & Imaging	www.ti.com/video
		Wireless	www.ti.com/wireless

Mailing Address: Texas Instruments
Post Office Box 655303 Dallas, Texas 75265