



10-Bit, 20MHz Sampling ANALOG-TO-DIGITAL CONVERTER

FEATURES

- NO MISSING CODES
- INTERNAL REFERENCE
- LOW DIFFERENTIAL LINEARITY ERROR:
0.2LSB
- LOW POWER: 195mW
- HIGH SNR: 60dB
- WIDEBAND TRACK/HOLD: 65MHz

APPLICATIONS

- SET-TOP BOXES
- CABLE MODEMS
- VIDEO DIGITIZING
- CCD IMAGING
 - Camcorders
 - Copiers
 - Scanners
 - Security Cameras
- IF AND BASEBAND DIGITIZATION

DESCRIPTION

The ADS820 is a low-power, monolithic 10-bit, 20MHz Analog-to-Digital (A/D) converter utilizing a small geometry CMOS process. This complete converter includes a 10-bit quantizer with internal track-and-hold, reference, and a power down feature. It operates from a single +5V power supply and can be configured to accept either differential or single-ended input signals.

The ADS820 employs digital error correction to provide excellent Nyquist differential linearity performance for demanding imaging applications. Its low distortion, high SNR, and high oversampling capability give it the extra margin needed for telecommunications and video applications.

This high performance converter is specified for AC and DC-performance at a 20MHz sampling rate. The ADS820 is available in an SO-28 package.

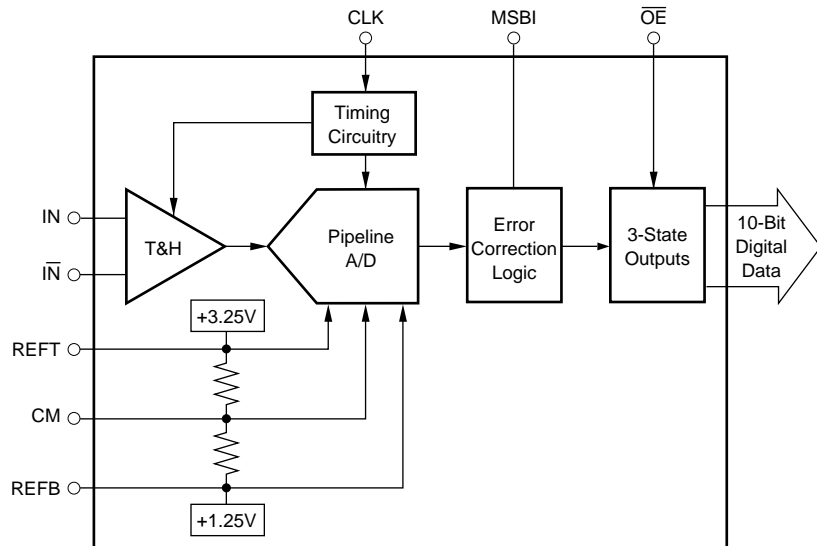

Please be aware that an important notice concerning availability, standard warranty, and use in critical applications of Texas Instruments semiconductor products and disclaimers thereto appears at the end of this data sheet.

All trademarks are the property of their respective owners.

ABSOLUTE MAXIMUM RATINGS⁽¹⁾

+V _S	+6V
Analog Input	0V to (+V _S + 300mV)
Logic Input	0V to (+V _S + 300mV)
Case Temperature	+100°C
Junction Temperature	+150°C
Storage Temperature	+125°C
External Top Reference Voltage (REFT)	+3.4V Max
External Bottom Reference Voltage (REFB)	+1.1V Min

NOTES: (1) Stresses above these ratings may cause permanent damage. Exposure to absolute maximum conditions for extended periods may degrade device reliability.



ELECTROSTATIC DISCHARGE SENSITIVITY

This integrated circuit can be damaged by ESD. Texas Instruments recommends that all integrated circuits be handled with appropriate precautions. Failure to observe proper handling and installation procedures can cause damage.

ESD damage can range from subtle performance degradation to complete device failure. Precision integrated circuits may be more susceptible to damage because very small parametric changes could cause the device not to meet its published specifications.

PACKAGE/ORDERING INFORMATION⁽¹⁾

PRODUCT	PACKAGE-LEAD	PACKAGE DESIGNATOR	SPECIFIED TEMPERATURE RANGE	PACKAGE MARKING	ORDERING NUMBER	TRANSPORT MEDIA, QUANTITY
ADS820	SO-8	DW	-40°C to +85°C	ADS820U	ADS820U	Rails, 28
"	"	"	"	"	ADS820U/1K	Tape and Reel, 1000

NOTE: (1) For the most current package and ordering information, see the Package Option Addendum at the end of this document, or see the TI website at www.ti.com.

ELECTRICAL CHARACTERISTICS

At T_A = +25°C, V_S = +5V, Sampling Rate = 20MHz, with a 50% duty cycle clock having a 2ns rise/fall time, unless otherwise noted.

PARAMETER	CONDITIONS	TEMP	ADS820U			UNITS
			MIN	TYP	MAX	
Resolution				10		Bits
Specified Temperature Range	T _{AMBIENT}		-40		+85	°C
ANALOG INPUT						
Differential Full-Scale Input Range			+1.25		+3.25	V
Common-Mode Voltage				2.25		V
Analog Input Bandwidth (-3dB)						
Small Signal	-20dBFS ⁽¹⁾ Input	+25°C		400		MHz
Full Power	0dB Input	+25°C		65		MHz
Input Impedance				1.25 4		MΩ pF
DIGITAL INPUT						
Logic Family				TTL/HCT Compatible CMOS		
Convert Command	Start Conversion			Falling Edge		
ACCURACY⁽²⁾						
Gain Error	f _s = 2.5MHz	+25°C		±0.6	±1.5	%
		Full		±1.0	±2.5	%
Gain Tempco				±85		ppm/°C
Power-Supply Rejection of Gain	Δ +V _S = ±5%	+25°C		0.01	0.1	%FSR/%
Input Offset Error		Full		±2.1	±3.0	%
Power-Supply Rejection of Offset	Δ +V _S = ±5%	+25°C		0.02	0.1	%FSR/%
CONVERSION CHARACTERISTICS						
Sample Rate			10k		20M	Sample/s
Data Latency				6.5		Convert Cycle
DYNAMIC CHARACTERISTICS						
Differential Linearity Error						
f = 500kHz		+25°C		±0.15	±1.0	LSB
		Full		±0.15	±1.0	LSB
f = 10MHz		+25°C		±0.2	±1.0	LSB
		Full		±0.2	±1.0	LSB
No Missing Codes		Full		Tested		
Integral Linearity Error at f = 500kHz		Full		±0.5	±2.0	LSB
Spurious-Free Dynamic Range (SFDR)						
f = 500kHz (-1dBFS input)		+25°C	67	77		dBFS
		Full	64	74		dBFS
f = 10MHz (-1dBFS input)		+25°C	59	63		dBFS
		Full	57	62		dBFS

NOTE: (1) dBFS refers to dB below Full Scale. (2) Percentage accuracies are referred to the internal A/D Converter Full-Scale Range of 4Vp-p. (3) IMD is referred to the larger of the two input signals. If referred to the peak envelope signal (= 0dB), the intermodulation products will be 7dB lower. (4) Based on (SINAD - 1.76)/6.02. (5) No "rollover" of bits.

ELECTRICAL CHARACTERISTICS (Cont.)

At $T_A = +25^\circ\text{C}$, $V_S = +5\text{V}$, Sampling Rate = 20MHz, with a 50% duty cycle clock having a 2ns rise/fall time, unless otherwise noted.

PARAMETER	CONDITIONS	TEMP	ADS820U, E			UNITS
			MIN	TYP	MAX	
Signal-to-Noise Ratio (SNR) f = 500kHz (-1dBFS input)		+25°C	58	60.5		dB
		Full	56	60		dB
f = 10MHz (-1dBFS input)		+25°C	58	60		dB
		Full	56	60		dB
Signal-to-(Noise + Distortion) (SINAD) f = 500kHz (-1dBFS input)		+25°C	58	60.5		dB
		Full	55	60		dB
f = 10MHz (-1dBFS input)		+25°C	56	58		dB
		Full	54	57		dB
Differential Gain Error	NTSC or PAL	+25°C		0.5		%
Differential Phase Error	NTSC or PAL	+25°C		0.1		degrees
Effective Bits ⁽⁴⁾	$f_{IN} = 3.58\text{MHz}$			9.5		Bits
Aperture Delay Time		+25°C		2		ns
Aperture Jitter		+25°C		7		ps rms
Overvoltage Recovery Time ⁽⁵⁾	1.5x Full-Scale Input	+25°C		2		ns
OUTPUTS			TTL/HCT Compatible CMOS SOB or BTC			
Logic Family	Logic Selectable					V
Logic Coding	Logic LOW, $C_L = 15\text{pF}$	Full	0		0.4	V
Logic Levels	Logic HIGH, $C_L = 15\text{pF}$	Full	2.5		+ V_S	V
3-State Enable Time				20	40	ns
3-State Disable Time		Full		2	10	ns
POWER-SUPPLY REQUIREMENTS						
Supply Voltage: + V_S	Operating	Full	+4.75	+5	+5.25	V
Supply Current: + I_S	Operating	+25°C		39	47	mA
	Operating	Full		40	55	mA
Power Consumption	Operating	+25°C		195	235	mW
	Operating	Full		200	275	mW
Thermal Resistance, θ_{JA} SO-28				75		°C/W

NOTE: (1) dBFS refers to dB below Full Scale. (2) Percentage accuracies are referred to the internal A/D Converter Full-Scale Range of 4Vp-p. (3) IMD is referred to the larger of the two input signals. If referred to the peak envelope signal ($\approx 0\text{dB}$), the intermodulation products will be 7dB lower. (4) Based on $(\text{SINAD} - 1.76)/6.02$. (5) No "rollover" of bits.

PIN CONFIGURATION

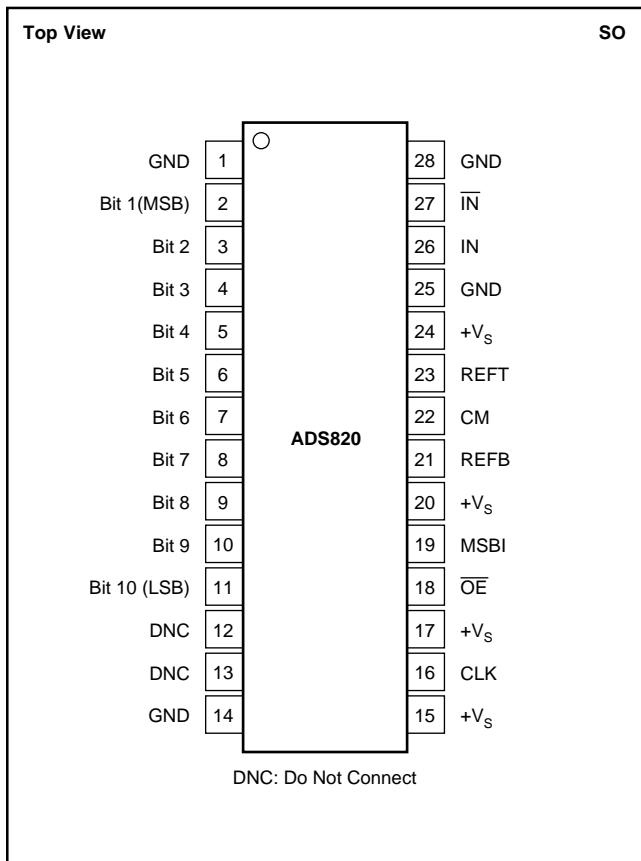

PIN DESCRIPTIONS

PIN	DESIGNATOR	DESCRIPTION
1	GND	Ground
2	B1	Bit 1, Most Significant Bit (MSB)
3	B2	Bit 2
4	B3	Bit 3
5	B4	Bit 4
6	B5	Bit 5
7	B6	Bit 6
8	B7	Bit 7
9	B8	Bit 8
10	B9	Bit 9
11	B10	Bit 10, Least Significant Bit (LSB)
12	DNC	Do not connect.
13	DNC	Do not connect.
14	GND	Ground
15	+V _S	+5V Power Supply
16	CLK	Convert Clock Input, 50% Duty Cycle
17	+V _S	+5V Power Supply
18	\overline{OE}	HIGH: High Impedance State. LOW or Floating: Normal Operation. Internal pull-down resistor.
19	MSBI	Most Significant Bit Inversion, HIGH: MSB inverted for complementary output. LOW or Floating: Straight output. Internal pull-down resistor.
20	+V _S	+5V Power Supply
21	REFB	Bottom Reference Bypass. For external bypassing of internal +1.25V reference.
22	CM	Common-Mode Voltage. It is derived by (REFT + REF B)/2.
23	REFT	Top Reference Bypass. For external bypassing of internal +3.25V reference.
24	+V _S	+5V Power Supply
25	GND	Ground
26	IN	Input
27	\overline{IN}	Complementary Input
28	GND	Ground

TIMING DIAGRAM

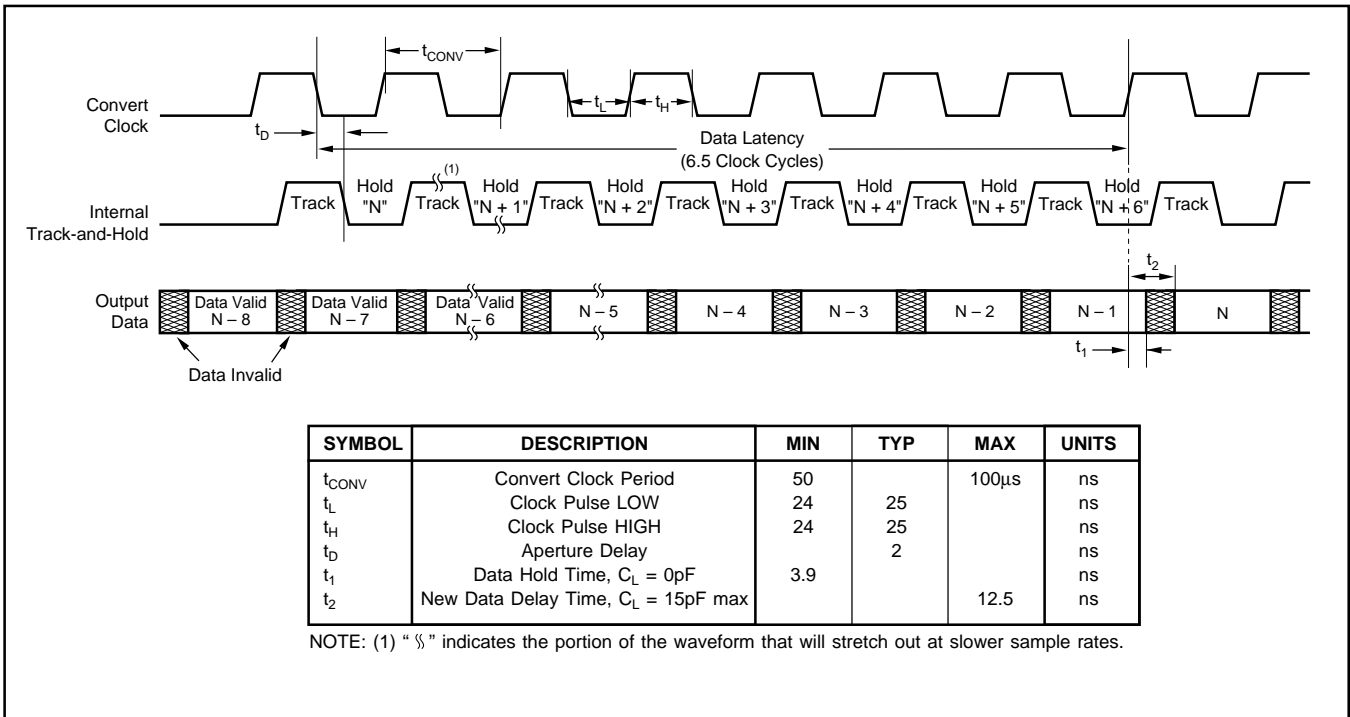

TYPICAL CHARACTERISTICS

At $T_A = +25^\circ\text{C}$, $V_S = +5\text{V}$, Sampling Rate = 20MHz, with a 50% duty cycle clock having a 2ns rise/fall time, unless otherwise noted.

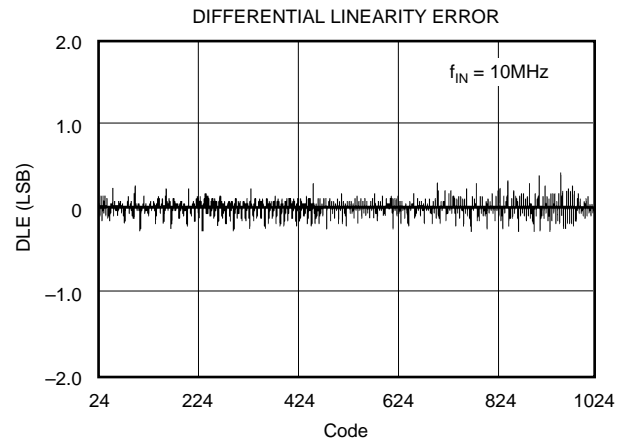
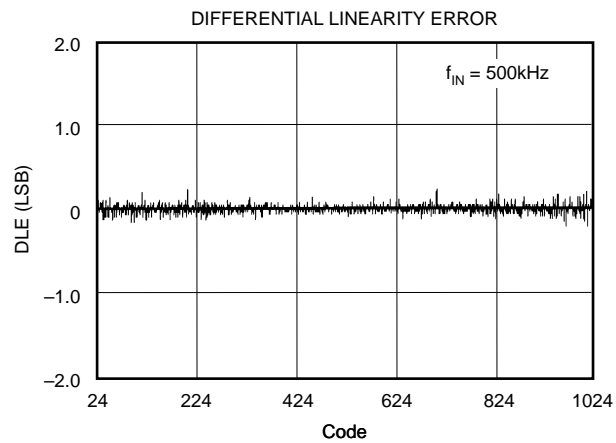
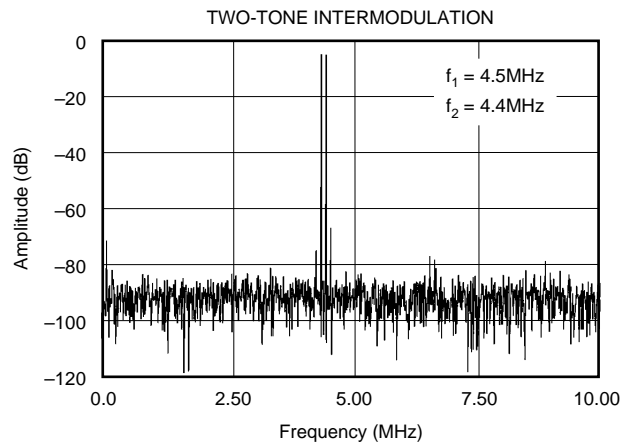
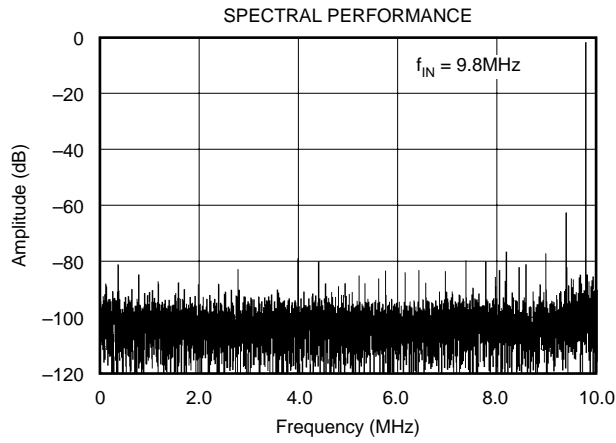
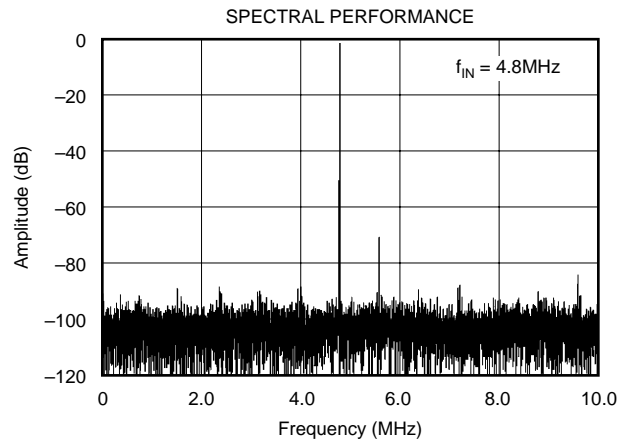
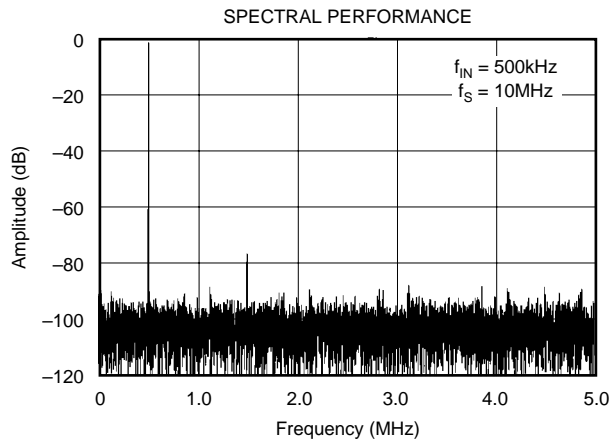

TYPICAL CHARACTERISTICS (Cont.)

At $T_A = +25^\circ\text{C}$, $V_S = +5\text{V}$, Sampling Rate = 20MHz, with a 50% duty cycle clock having a 2ns rise/fall time, unless otherwise noted.

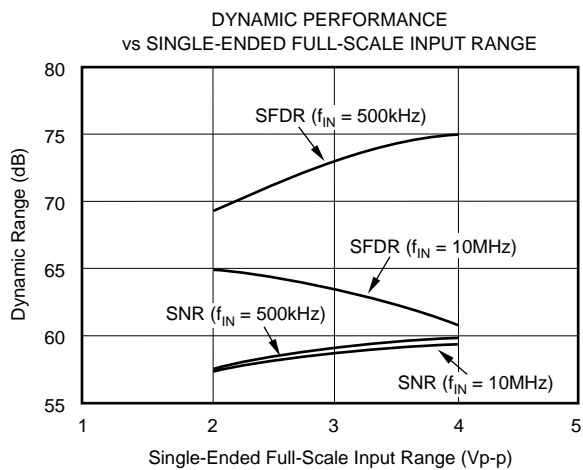
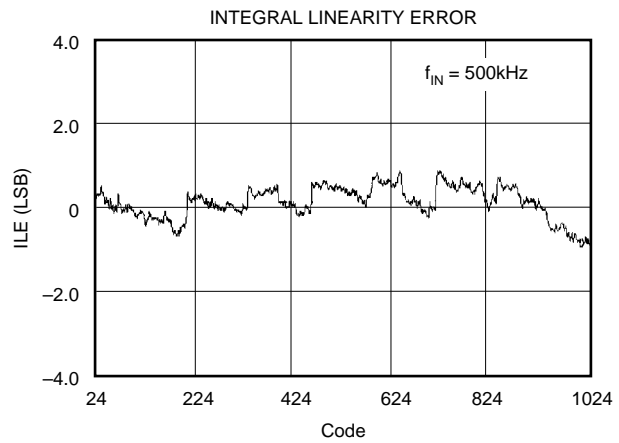
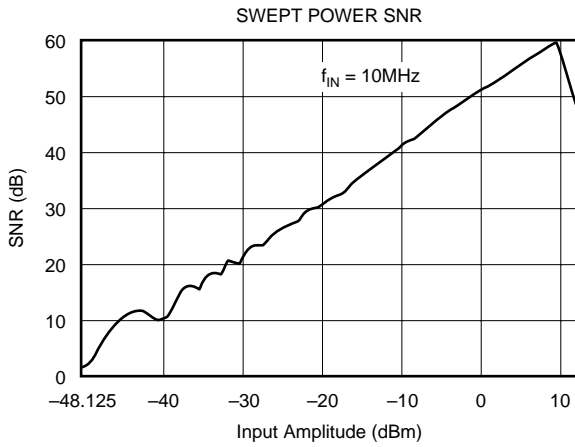
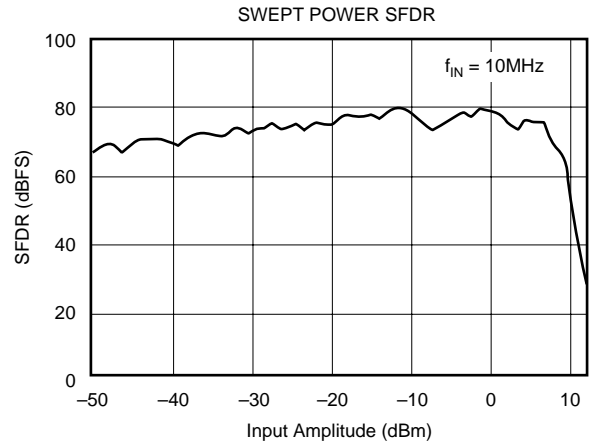
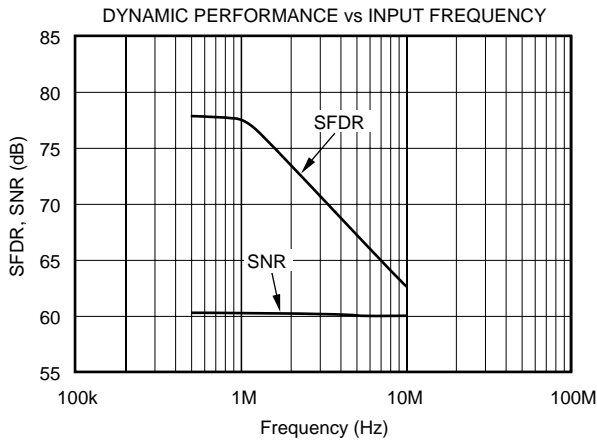

NOTE: REF_{EXT} varied, REF_B is fixed at the internal value of +1.25V.

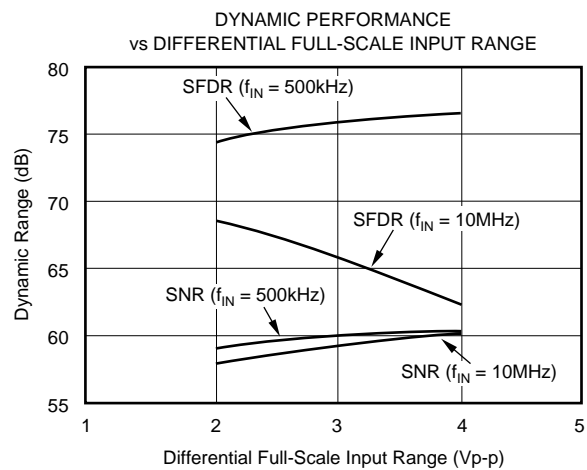

NOTE: REF_{EXT} varied, REF_B is fixed at internal value of +1.25V.

TYPICAL CHARACTERISTICS (Cont.)

At $T_A = +25^\circ\text{C}$, $V_S = +5\text{V}$, Sampling Rate = 20MHz, with a 50% duty cycle clock having a 2ns rise/fall time, unless otherwise noted.

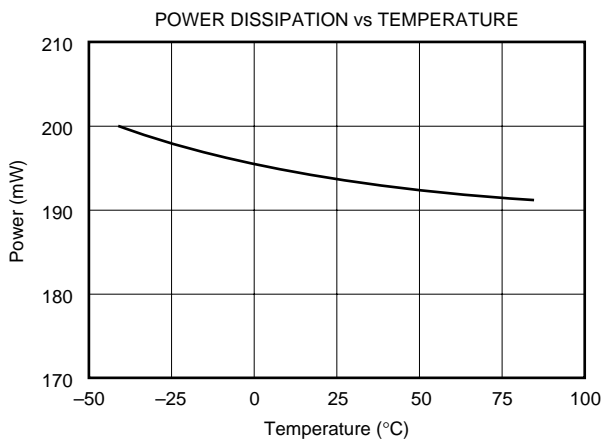
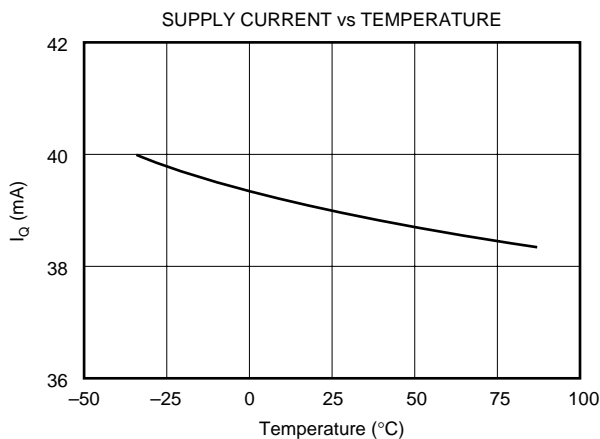
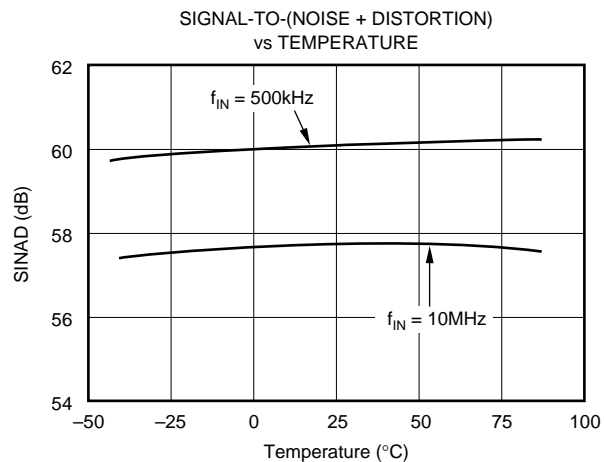
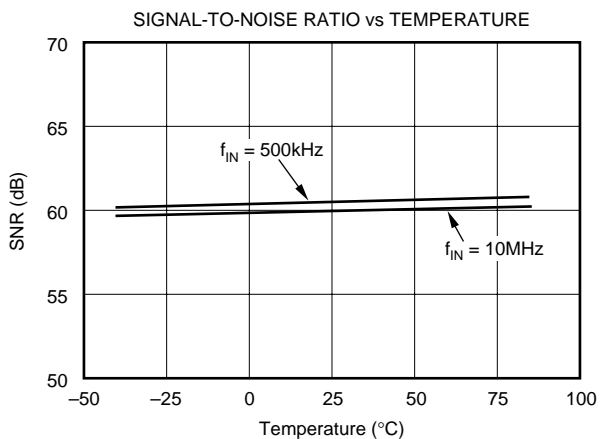
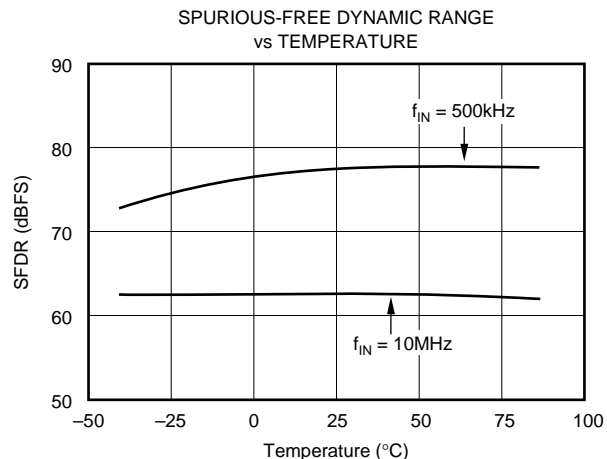
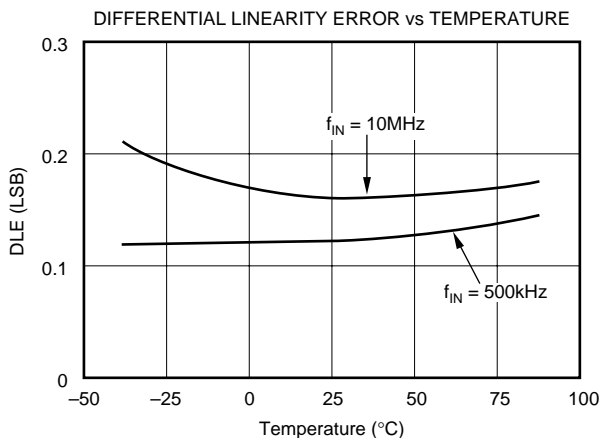

TYPICAL CHARACTERISTICS (Cont.)

At $T_A = +25^\circ\text{C}$, $V_S = +5\text{V}$, Sampling Rate = 20MHz, with a 50% duty cycle clock having a 2ns rise/fall time, unless otherwise noted.

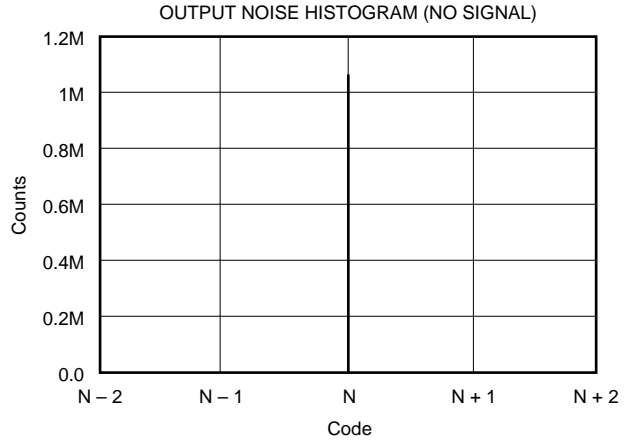
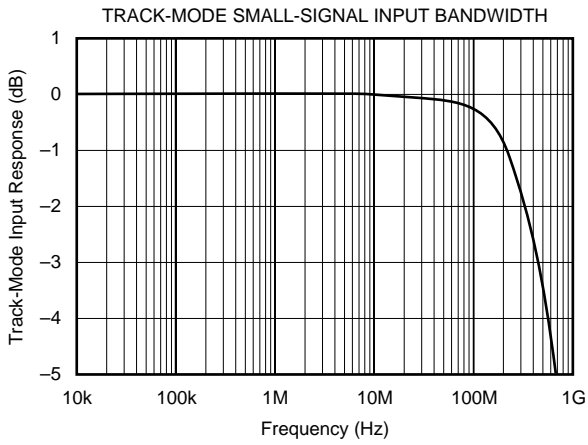
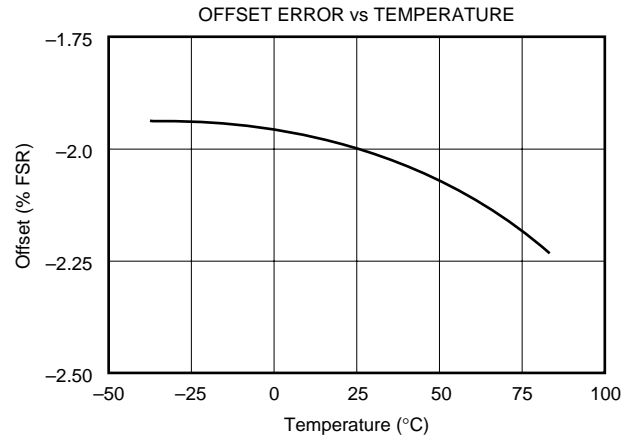
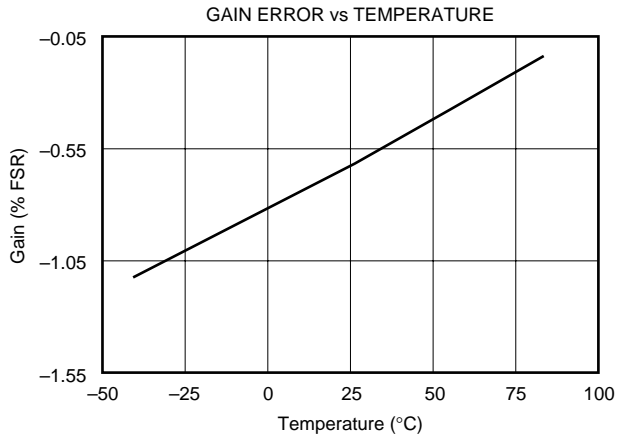

THEORY OF OPERATION

The ADS820 is a high-speed, sampling A/D converter with pipelining. It uses a fully differential architecture and digital error correction to ensure 10-bit resolution. The differential track-and-hold circuit is shown in Figure 1. The switches are controlled by an internal clock that has a non-overlapping, two-phase signal, ϕ_1 and ϕ_2 . At the sampling time the input signal is sampled on the bottom plates of the input capacitors. In the next clock phase, ϕ_2 , the bottom plates of the input capacitors are connected together and the feedback capacitors are switched to the op amp output. At this time, the charge redistributes between C_1 and C_H , completing one track-and-hold cycle. The differential output is a held DC representation of the analog input at the sample time. The track-and-hold circuit can also convert a single-ended input signal into a fully differential signal for the quantizer.

The pipelined quantizer architecture has nine stages with each stage containing a 2-bit quantizer and a 2-bit Digital-to-Analog Converter (DAC), as shown in Figure 2. Each 2-bit quantizer stage converts on the edge of the sub-clock, which is twice the frequency of the externally applied clock. The output of each quantizer is fed into its own delay line to

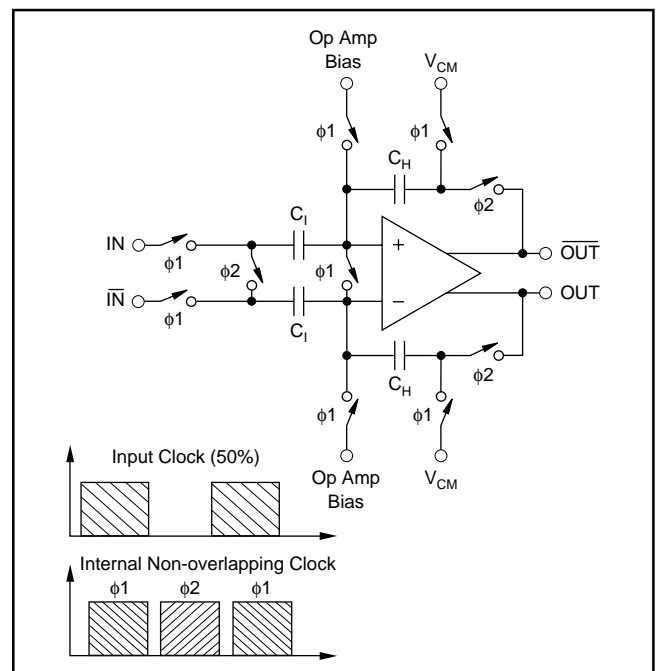

FIGURE 1. Input Track-and-Hold Configuration with Timing Signals.

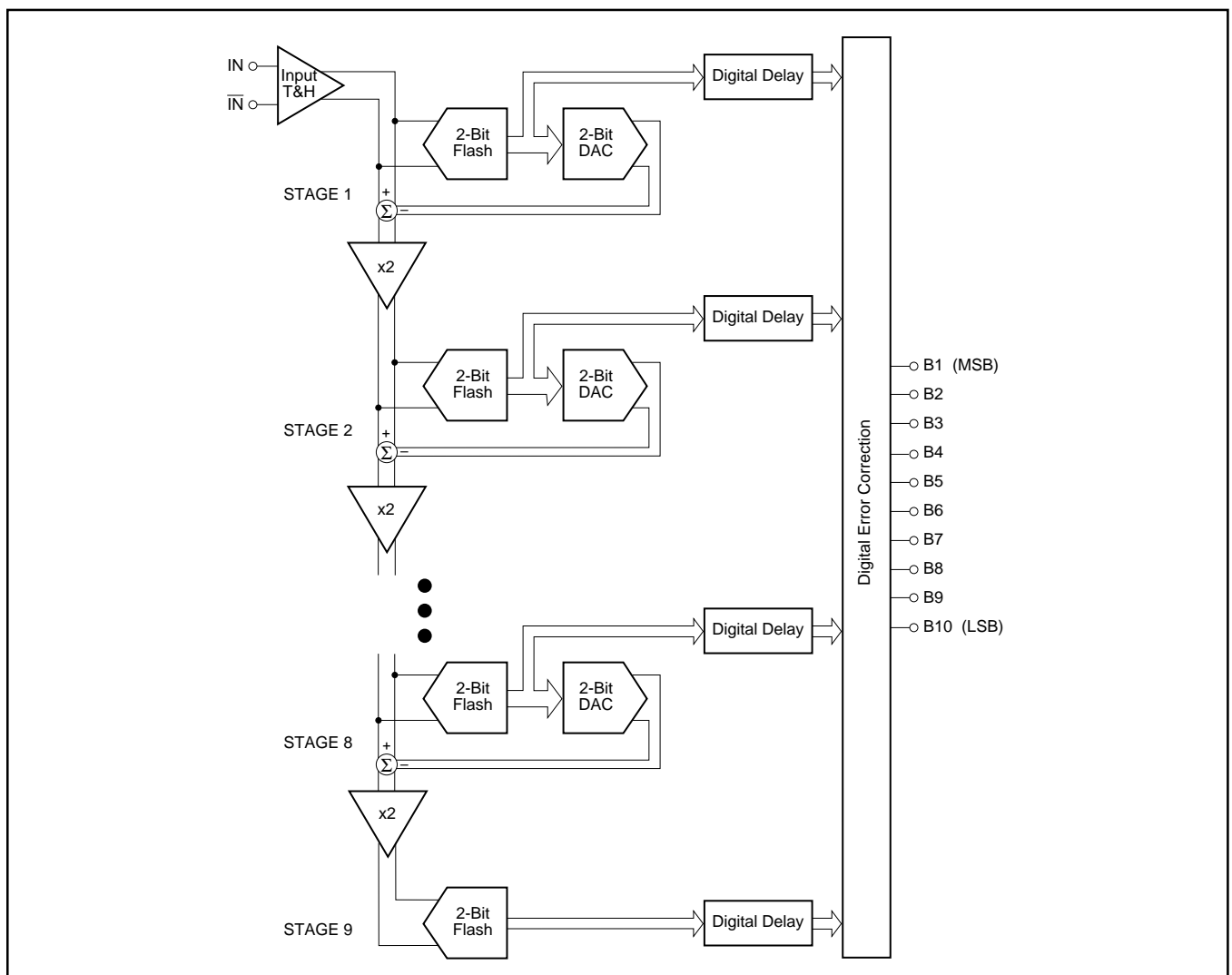

FIGURE 2. Pipeline A/D Converter Architecture.

time-align it with the data created from the following quantizer stages. This aligned data is fed into a digital error correction circuit that can adjust the output data based on the information found on the redundant bits. This technique gives the ADS820 excellent differential linearity and ensures no missing codes at the 10-bit level.

There is a 6.5 clock cycle data latency from the start convert signal to the valid output data. The output data is available in Straight Offset Binary (SOB) or Binary Two's Complement (BTC) format.

THE ANALOG INPUT AND INTERNAL REFERENCE

The analog input of the ADS820 can be configured in various ways and driven with different circuits, depending on the nature of the signal and the level of performance desired. The ADS820 has an internal reference that sets the full-scale input range of the A/D converter. The differential input range has each input centered around the common-mode of +2.25V, with each of the two inputs having a full-scale range of +1.25V to +3.25V. Since each input is 2Vp-p and 180° out-of-phase with the other, a 4V differential input signal to the quantizer results. The positive full-scale reference (REFT) and the negative full-scale reference (REFB) are brought out for external bypassing, as shown in Figure 3. In addition, the common-mode (CM) voltage may be used as a reference to provide the appropriate offset for the driving circuitry. However, care must be taken not to appreciably load this reference node. For more information regarding external references, single-ended inputs, and ADS820 drive circuits, refer to the applications section.

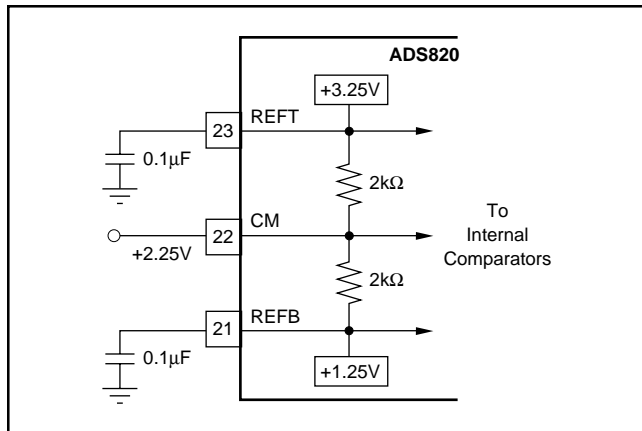

FIGURE 3. Internal Reference Structure.

CLOCK REQUIREMENTS

The CLK pin accepts a CMOS level clock input. The rising and falling edge of the externally applied convert command clock controls the various interstage conversions in the pipeline. Therefore, the duty cycle of the clock should be held at 50% with low jitter and fast rise and fall times of 2ns or less. This is especially important when digitizing a high-frequency input and operating at the maximum sample rate. Deviation from a 50% duty cycle will effectively shorten some of the interstage settling times, thus degrading the SNR and DNL performance.

DIGITAL OUTPUT DATA

The 10-bit output data is provided at CMOS logic levels. The standard output coding is Straight Offset Binary where a full-scale input signal corresponds to all "1's" at the output. This condition is met with pin 19 LOW or Floating due to an internal pull-down resistor. By applying a high voltage to this pin, a BTC output will be provided where the most significant bit is inverted. The digital outputs of the ADS820 can be set to a high impedance state by driving \overline{OE} (pin 18) with a logic HIGH. Normal operation is achieved with pin 18 LOW or Floating due to internal pull-down resistors. This function is provided for testability purposes and is not meant to drive digital buses directly or be dynamically changed during the conversion process.

DIFFERENTIAL INPUT ⁽¹⁾	OUTPUT CODE	
	SOB PIN 19 FLOATING or LOW	BTC PIN 19 HIGH
+FS (IN = +3.25V, \overline{IN} = +1.25V)	1111111111	0111111111
+FS -1LSB	1111111111	0111111111
+FS -2LSB	1111111110	0111111110
+3/4 Full Scale	1110000000	0110000000
+1/2 Full Scale	1100000000	0100000000
+1/4 Full Scale	1010000000	0010000000
+1LSB	1000000001	0000000001
Bipolar Zero (IN = \overline{IN} = +2.25V)	1000000000	0000000000
-1LSB	0111111111	1111111111
-1/4 Full Scale	0110000000	1110000000
-1/2 Full Scale	0100000000	1100000000
-3/4 Full Scale	0010000000	1010000000
-FS +1LSB	0000000001	1000000001
-FS (IN = +1.25V, \overline{IN} = +3.25V)	0000000000	1000000000

NOTE: (1) In the single-ended input mode, +FS = +4.25V and -FS = +0.25V.

TABLE I. Coding Table for the ADS820.

APPLICATIONS

DRIVING THE ADS820

The ADS820 has a differential input with a common mode of +2.25V. For AC-coupled applications, the simplest way to create this differential input is to drive the primary winding of a transformer with a single-ended input. A differential output is created on the secondary if the center tap is tied to the (CM) voltage of +2.25V, as per Figure 4. This transformer-coupled input arrangement provides good high frequency

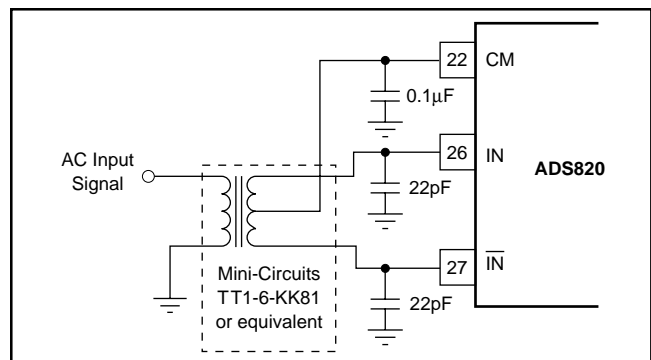

FIGURE 4. AC-Coupled Single-Ended to Differential Drive Circuit Using a Transformer.

AC performance. It is important to select a transformer that gives low distortion and does not exhibit core saturation at full-scale voltage levels. Since the transformer does not appreciably load the ladder, there is no need to buffer the CM output in this instance. In general, it is advisable to keep the current draw from the CM output pin below $0.5\mu\text{A}$ to avoid nonlinearity in the internal reference ladder. A FET input operational amplifier, such as the OPA130, can provide a buffered reference for driving external circuitry. The analog IN and $\overline{\text{IN}}$ inputs should be bypassed with 22pF capacitors to minimize track-and-hold glitches and to improve high-input frequency performance.

Figure 5 illustrates another possible low-cost interface circuit that utilizes resistors and capacitors in place of a transformer. Depending on the signal bandwidth, the component values should be carefully selected in order to maintain the performance outlined in the data sheet. The input capacitors, C_{IN} , and the input resistors, R_{IN} , create a high-pass filter with the lower corner frequency at $f_c = 1/(2\pi R_{\text{IN}} C_{\text{IN}})$. The corner frequency can be reduced by either increasing the value of R_{IN} or C_{IN} . If the circuit operates with a 50Ω or 75Ω impedance level, the resistors are fixed and only the value of the capacitor can be increased. Usually AC-coupling capacitors are electrolytic or tantalum capacitors with values of $1\mu\text{F}$ or higher. It should be noted that these large capacitors become inductive with increased input frequency, which could lead to signal amplitude errors or oscillation. To maintain a low ac-coupling impedance throughout the signal band, a small value (e.g. $1\mu\text{F}$) ceramic capacitor could be added in parallel with the polarized capacitor.

Capacitors $C_{\text{SH}1}$ and $C_{\text{SH}2}$ are used to minimize current glitches resulting from the switching in the input track and hold stage and to improve signal-to-noise performance. These capacitors can also be used to establish a low-pass filter and effectively reduce the noise bandwidth. In order to create a real pole, resistors $R_{\text{SER}1}$ and $R_{\text{SER}2}$ were added in series with

each input. The cutoff frequency of the filter is determined by $f_c = 1/(2\pi R_{\text{SER}} \cdot (C_{\text{SH}} + C_{\text{ADC}}))$ where R_{SER} is the resistor in series with the input, C_{SH} is the external capacitor from the input to ground, and C_{ADC} is the internal input capacitance of the A/D converter (typically 4pF).

Resistors R_1 and R_2 are used to derive the necessary common-mode voltage from the buffered top and bottom references. The total load of the resistor string should be selected so that the current does not exceed 1mA. Although the circuit in Figure 5 uses two resistors of equal value so that the common-mode voltage is centered between the top and bottom reference ($+2.25\text{V}$), it is not necessary to do so. In all cases the center point, V_{CM} , should be bypassed to ground in order to provide a low-impedance ac ground.

If the signal needs to be DC-coupled to the input of the ADS820, an operational amplifier input circuit is required. In the differential input mode, any single-ended signal must be modified to create a differential signal. This can be accomplished by using two operational amplifiers; one in the noninverting mode for the input and the other amplifier in the inverting mode for the complementary input. The low distortion circuit in Figure 6 will provide the necessary input shifting required for signals centered around ground. It also employs a diode for output level shifting to ensure a low distortion $+3.25\text{V}$ output swing. Another DC-coupled circuit is shown in Figure 7. Other amplifiers can be used in place of the OPA860s if the lowest distortion is not necessary. If output level shifting circuits are not used, care must be taken to select operational amplifiers that give the necessary performance when swinging to $+3.25\text{V}$ with a $\pm 5\text{V}$ supply operational amplifier. The OPA620 and OPA621, or the lower power OPA820 can be used in place of the OPA860s in Figure 6. In that configuration, the OPA820 will typically swing to within 100mV of positive full scale.

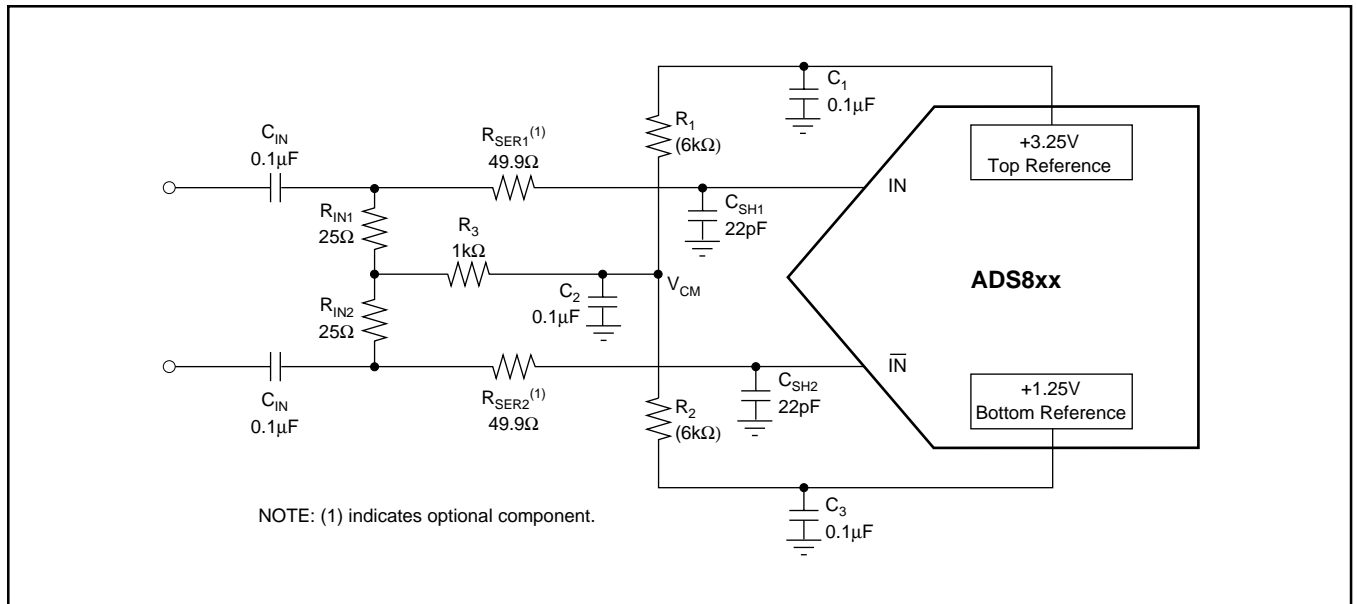

FIGURE 5. AC-Coupled Differential Input Circuit.

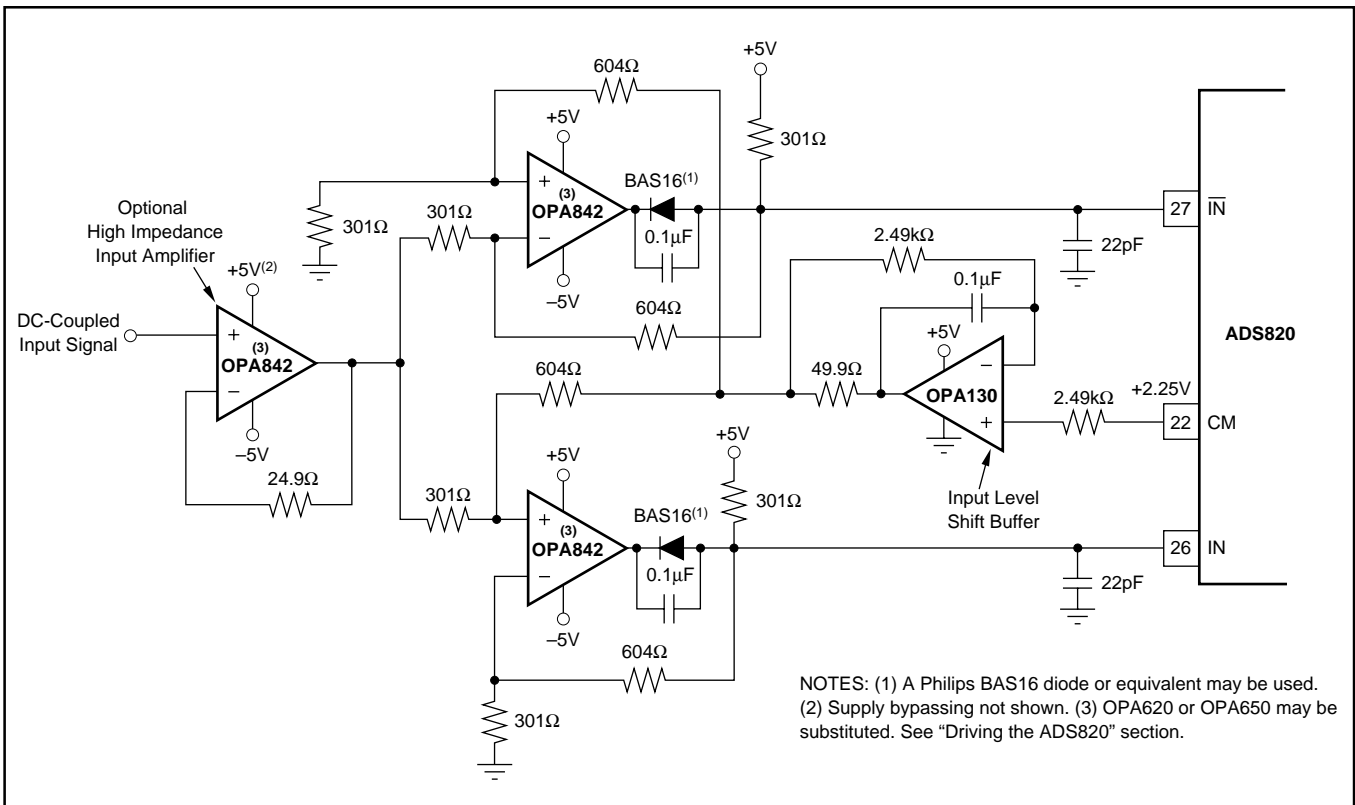

FIGURE 6. A Low Distortion DC-Coupled, Single-Ended to Differential Input Driver Circuit.

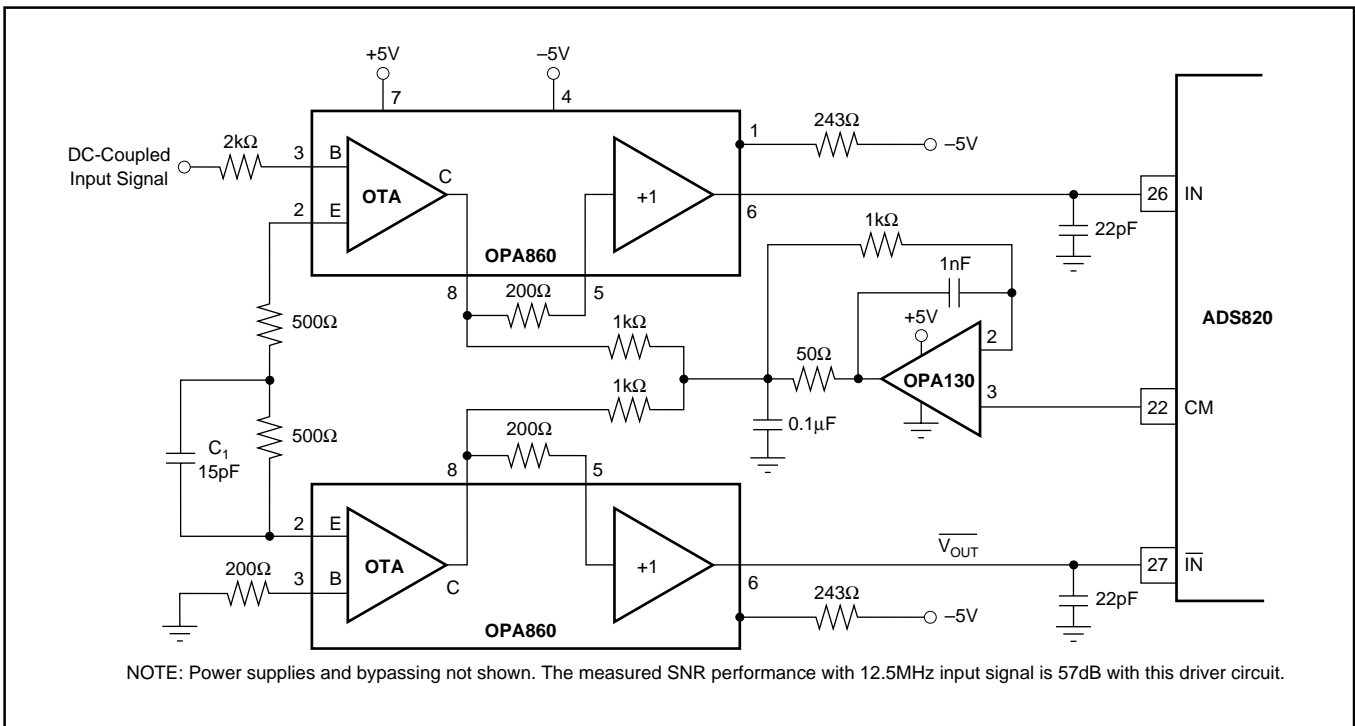

FIGURE 7. A Wideband DC-Coupled, Single-Ended to Differential Input Driver Circuit.

The ADS820 can also be configured with a single-ended input full-scale range of +0.25V to +4.25V by tying the complementary input to the common-mode reference voltage, as shown in Figure 8. This configuration will result in increased even-order harmonics, especially at higher input frequencies. However, this trade-off may be quite acceptable for time-domain applications. The driving amplifier must give adequate performance with a +0.25V to +4.25V output swing in this case.

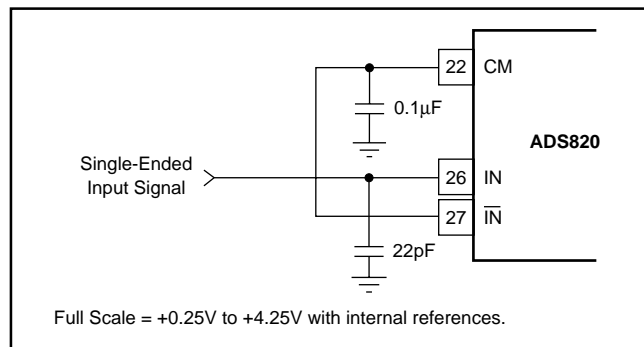

FIGURE 8. Single-Ended Input Connection.

EXTERNAL REFERENCES AND ADJUSTMENT OF FULL-SCALE RANGE

The internal reference buffers are limited to approximately 1mA of output current. As a result, these internal +1.25V and +3.25V references may be overridden by external references that have at least 18mA (at room temperature) of output drive capability. In this instance, the common-mode voltage will be

set halfway between the two references. This feature can be used to adjust the gain error, improve gain drift, or to change the full-scale input range of the ADS820. Changing the full-scale range to a lower value has the benefit of easing the swing requirements of external input amplifiers. The external references can vary as long as the value of the external top reference (REF_{T_EXT}) is less than or equal to +3.4V, the value of the external bottom reference (REF_{B_EXT}) is greater than or equal to +1.1V, and the difference between the external references are greater than or equal to 800mV.

For the differential configuration, the full-scale input range will be set to the external reference values that are selected. For the single-ended mode, the input range is $2 \cdot (REF_{T_EXT} - REF_{B_EXT})$, with the common-mode being centered at $(REF_{T_EXT} + REF_{B_EXT})/2$. Refer to the typical performance curves for expected performance versus full-scale input range.

The circuit in Figure 9 works completely on a single +5V supply. As a reference element, it uses micro-power reference REF1004-2.5, which is set to a quiescent current of 0.1mA. Amplifier A_2 is configured as a follower to buffer the +1.25V generated from the resistor divider. To provide the necessary current drive, a pull-down resistor, R_P , is added.

Amplifier A_1 is configured as an adjustable gain stage, with a range of approximately 1 to 1.32. The pull-up resistor again relieves the op amp from providing the full current drive. The value of the pull-up and pull-down resistors is not critical and can be varied to optimize power consumption. The need for pull-up/down resistors depends only on the drive capability of the selected drive amplifiers and thus can be omitted.

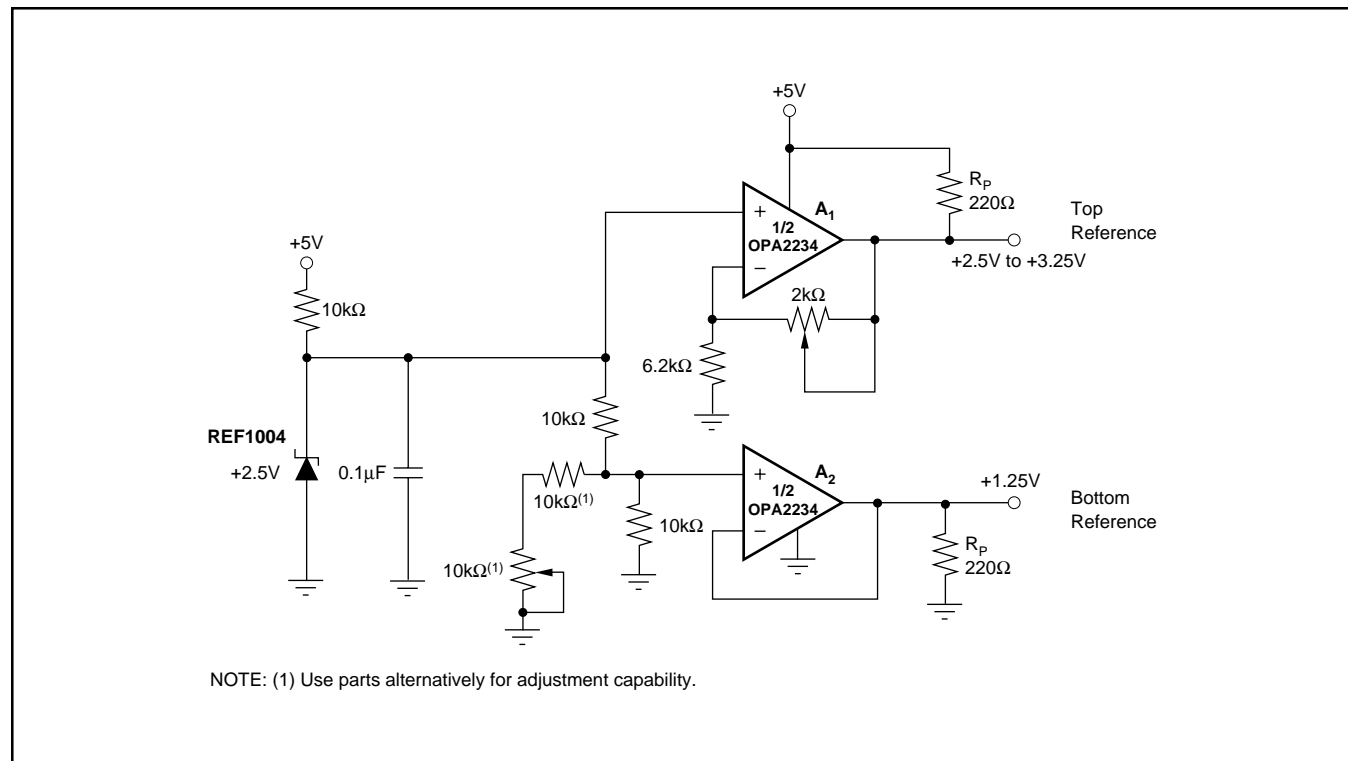

FIGURE 9. Optional External Reference to Set the Full-Scale Range Utilizing a Dual, Single-Supply Op Amp.

PC-BOARD LAYOUT AND BYPASSING

A well-designed, clean PC-board layout will assure proper operation and clean spectral response. Proper grounding and bypassing, short lead lengths, and the use of ground planes are particularly important for high frequency circuits. Multilayer PC boards are recommended for best performance but if carefully designed, a two-sided pc board with large, heavy ground planes can give excellent results. It is recommended that the analog and digital ground pins of the ADS820 be connected directly to the analog ground plane. In our experience, this gives the most consistent results. The A/D converter power-supply commons should be tied together at the analog ground plane. Power supplies should be bypassed with 0.1 μ F ceramic capacitors as close to the pin as possible.

DYNAMIC PERFORMANCE TESTING

The ADS820 is a high-performance converter and careful attention to test techniques is necessary to achieve accurate results. Highly accurate phase-locked signal sources allow high-resolution FFT measurements to be made without using data windowing functions. A low jitter signal generator such as the HP8644A for the test signal, phase-locked with a low jitter HP8022A pulse generator for the A/D converter clock,

gives excellent results. Low-pass filtering (or bandpass filtering) of test signals is absolutely necessary to test the low distortion of the ADS820. Using a signal amplitude slightly lower than full scale will allow a small amount of "headroom" so that noise or DC-offset voltage will not overrange the A/D converter and cause clipping on signal peaks.

DYNAMIC PERFORMANCE DEFINITIONS

1. Signal-to-Noise-and-Distortion Ratio (SINAD):

$$10 \log \frac{\text{Sinewave Signal Power}}{\text{Noise + Harmonic Power (first 15 harmonics)}}$$

2. Signal-to-Noise Ratio (SNR):

$$10 \log \frac{\text{Sinewave Signal Power}}{\text{Noise Power}}$$

3. Intermodulation Distortion (IMD):

$$10 \log \frac{\text{Highest IMD Product Power (to 5th order)}}{\text{Sinewave Signal Power}}$$

IMD is referenced to the larger of the test signals f_1 or f_2 . Five "bins" either side of peak are used for calculation of fundamental and harmonic power. The "0" frequency bin (DC) is not included in these calculations, as it is of little importance in dynamic signal processing applications.

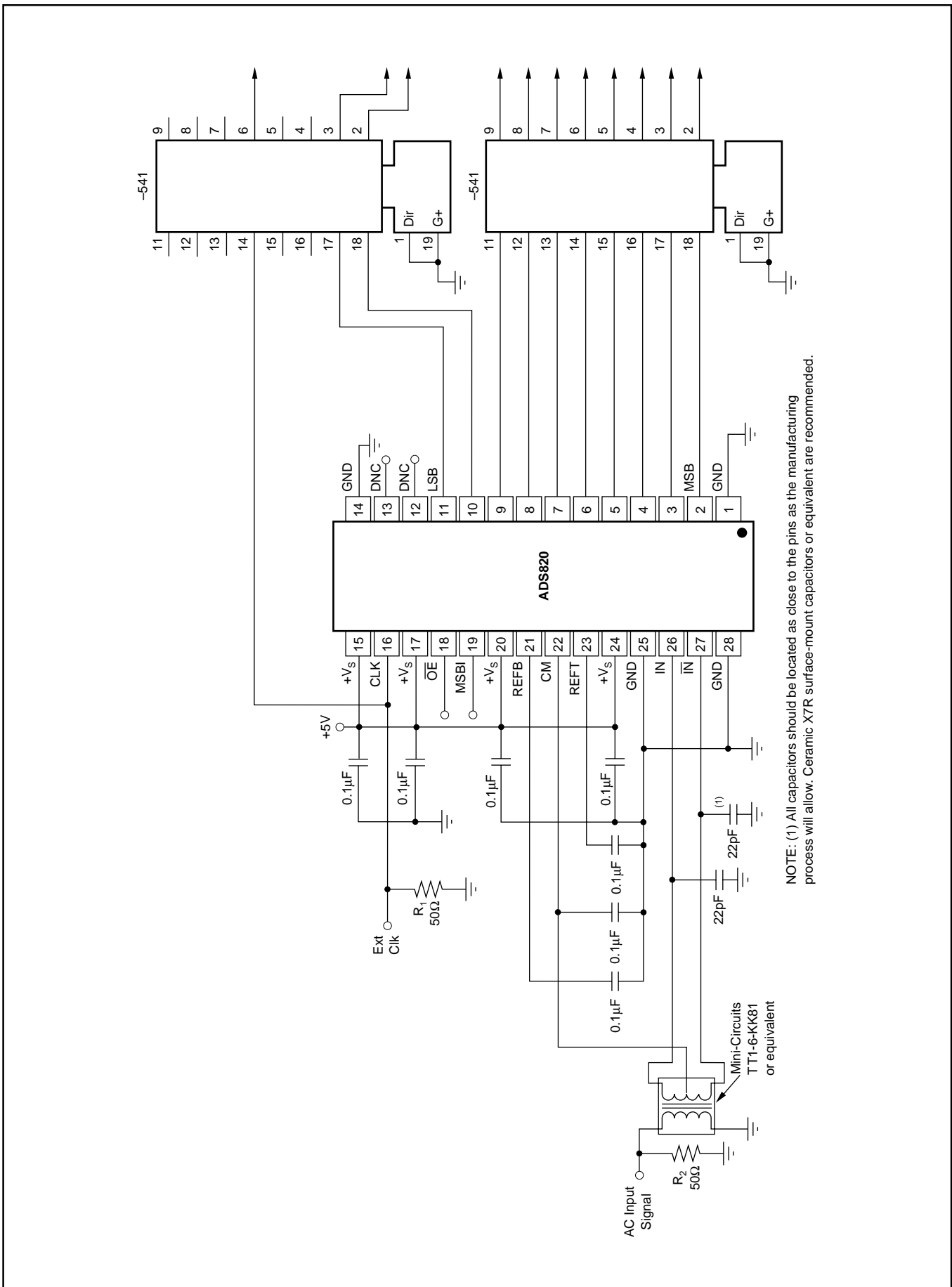

FIGURE 10. ADS820 Interface Schematic with AC-Coupling and External Buffers.

PACKAGING INFORMATION

Orderable Device	Status ⁽¹⁾	Package Type	Package Drawing	Pins	Package Qty	Eco Plan ⁽²⁾	Lead/Ball Finish	MSL Peak Temp ⁽³⁾
ADS820E	OBSOLETE	SSOP	DB	28		None	Call TI	Call TI
ADS820E/1K	OBSOLETE	SSOP	DB	28		None	Call TI	Call TI
ADS820U	ACTIVE	SOIC	DW	28	28	None	CU SNPB	Level-3-220C-168 HR
ADS820U/1K	ACTIVE	SOIC	DW	28	1000	None	CU SNPB	Level-3-220C-168 HR

⁽¹⁾ The marketing status values are defined as follows:

ACTIVE: Product device recommended for new designs.

LIFEBUY: TI has announced that the device will be discontinued, and a lifetime-buy period is in effect.

NRND: Not recommended for new designs. Device is in production to support existing customers, but TI does not recommend using this part in a new design.

PREVIEW: Device has been announced but is not in production. Samples may or may not be available.

OBSOLETE: TI has discontinued the production of the device.

⁽²⁾ Eco Plan - May not be currently available - please check <http://www.ti.com/productcontent> for the latest availability information and additional product content details.

None: Not yet available Lead (Pb-Free).

Pb-Free (RoHS): TI's terms "Lead-Free" or "Pb-Free" mean semiconductor products that are compatible with the current RoHS requirements for all 6 substances, including the requirement that lead not exceed 0.1% by weight in homogeneous materials. Where designed to be soldered at high temperatures, TI Pb-Free products are suitable for use in specified lead-free processes.

Green (RoHS & no Sb/Br): TI defines "Green" to mean "Pb-Free" and in addition, uses package materials that do not contain halogens, including bromine (Br) or antimony (Sb) above 0.1% of total product weight.

⁽³⁾ MSL, Peak Temp. -- The Moisture Sensitivity Level rating according to the JEDEC industry standard classifications, and peak solder temperature.

Important Information and Disclaimer: The information provided on this page represents TI's knowledge and belief as of the date that it is provided. TI bases its knowledge and belief on information provided by third parties, and makes no representation or warranty as to the accuracy of such information. Efforts are underway to better integrate information from third parties. TI has taken and continues to take reasonable steps to provide representative and accurate information but may not have conducted destructive testing or chemical analysis on incoming materials and chemicals. TI and TI suppliers consider certain information to be proprietary, and thus CAS numbers and other limited information may not be available for release.

In no event shall TI's liability arising out of such information exceed the total purchase price of the TI part(s) at issue in this document sold by TI to Customer on an annual basis.

DW (R-PDSO-G28)

PLASTIC SMALL-OUTLINE PACKAGE

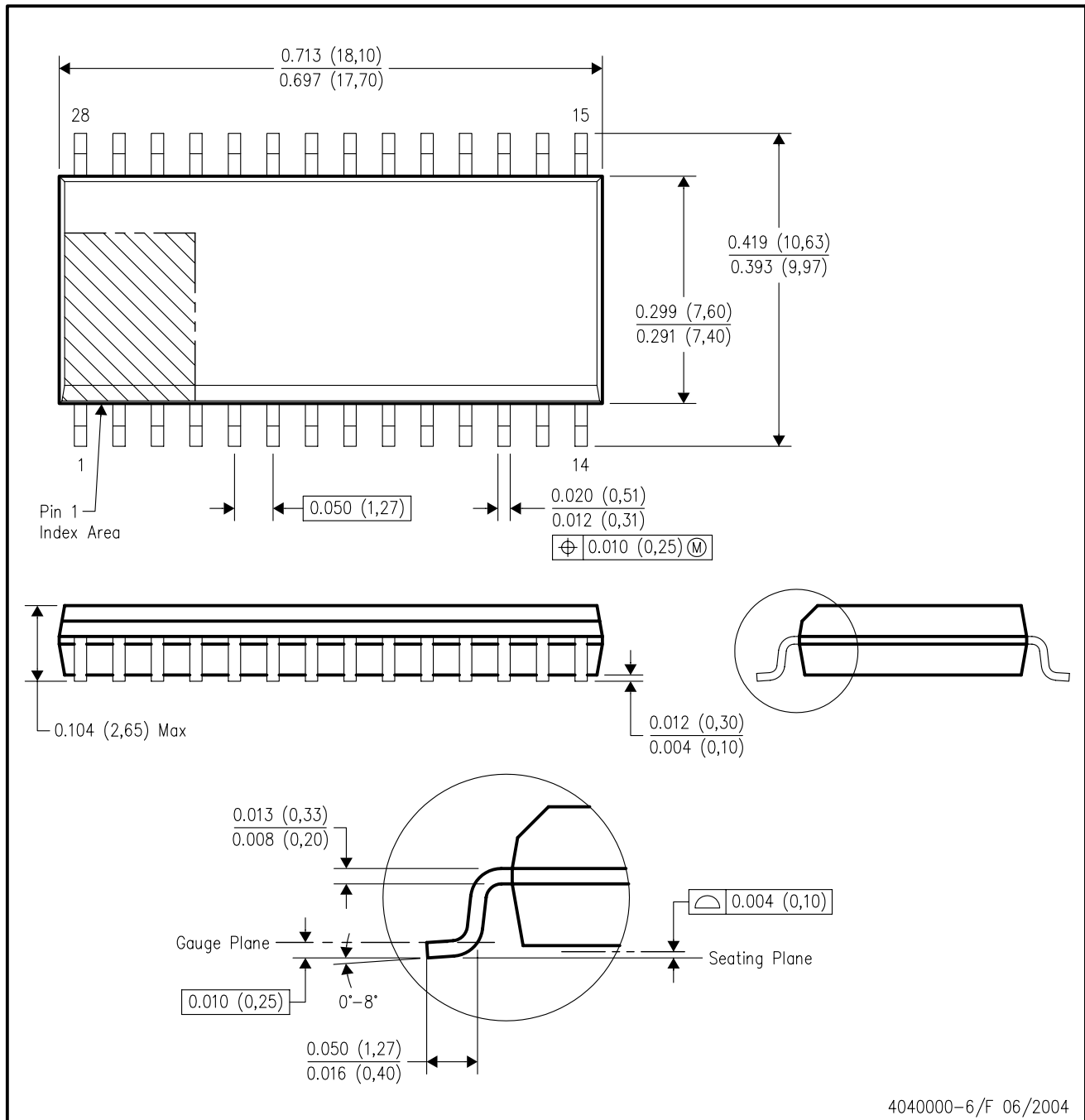

- NOTES:
- A. All linear dimensions are in inches (millimeters).
 - B. This drawing is subject to change without notice.
 - C. Body dimensions do not include mold flash or protrusion not to exceed 0.006 (0,15).
 - D. Falls within JEDEC MS-013 variation AE.

IMPORTANT NOTICE

Texas Instruments Incorporated and its subsidiaries (TI) reserve the right to make corrections, modifications, enhancements, improvements, and other changes to its products and services at any time and to discontinue any product or service without notice. Customers should obtain the latest relevant information before placing orders and should verify that such information is current and complete. All products are sold subject to TI's terms and conditions of sale supplied at the time of order acknowledgment.

TI warrants performance of its hardware products to the specifications applicable at the time of sale in accordance with TI's standard warranty. Testing and other quality control techniques are used to the extent TI deems necessary to support this warranty. Except where mandated by government requirements, testing of all parameters of each product is not necessarily performed.

TI assumes no liability for applications assistance or customer product design. Customers are responsible for their products and applications using TI components. To minimize the risks associated with customer products and applications, customers should provide adequate design and operating safeguards.

TI does not warrant or represent that any license, either express or implied, is granted under any TI patent right, copyright, mask work right, or other TI intellectual property right relating to any combination, machine, or process in which TI products or services are used. Information published by TI regarding third-party products or services does not constitute a license from TI to use such products or services or a warranty or endorsement thereof. Use of such information may require a license from a third party under the patents or other intellectual property of the third party, or a license from TI under the patents or other intellectual property of TI.

Reproduction of information in TI data books or data sheets is permissible only if reproduction is without alteration and is accompanied by all associated warranties, conditions, limitations, and notices. Reproduction of this information with alteration is an unfair and deceptive business practice. TI is not responsible or liable for such altered documentation.

Resale of TI products or services with statements different from or beyond the parameters stated by TI for that product or service voids all express and any implied warranties for the associated TI product or service and is an unfair and deceptive business practice. TI is not responsible or liable for any such statements.

Following are URLs where you can obtain information on other Texas Instruments products and application solutions:

Products		Applications	
Amplifiers	amplifier.ti.com	Audio	www.ti.com/audio
Data Converters	dataconverter.ti.com	Automotive	www.ti.com/automotive
DSP	dsp.ti.com	Broadband	www.ti.com/broadband
Interface	interface.ti.com	Digital Control	www.ti.com/digitalcontrol
Logic	logic.ti.com	Military	www.ti.com/military
Power Mgmt	power.ti.com	Optical Networking	www.ti.com/opticalnetwork
Microcontrollers	microcontroller.ti.com	Security	www.ti.com/security
		Telephony	www.ti.com/telephony
		Video & Imaging	www.ti.com/video
		Wireless	www.ti.com/wireless

Mailing Address: Texas Instruments
Post Office Box 655303 Dallas, Texas 75265