

AM26LS31C, AM26LS31M QUADRUPLE DIFFERENTIAL LINE DRIVER

SLLS114H – JANUARY 1979 – REVISED JULY 2002

- Meets or Exceeds the Requirements of ANSI TIA/EIA-422-B and ITU Recommendation V.11
- Operates From a Single 5-V Supply
- TTL Compatible
- Complementary Outputs
- High Output Impedance in Power-Off Conditions
- Complementary Output-Enable Inputs

D, DB, N, NS, OR J PACKAGE
(TOP VIEW)

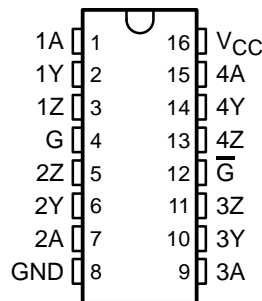

description/ordering information

The AM26LS31 is a quadruple complementary-output line driver designed to meet the requirements of ANSI TIA/EIA-422-B and ITU (formerly CCITT) Recommendation V.11. The 3-state outputs have high-current capability for driving balanced lines such as twisted-pair or parallel-wire transmission lines, and they are in the high-impedance state in the power-off condition. The enable function is common to all four drivers and offers the choice of an active-high or active-low enable (\overline{G} , \overline{G}) input. Low-power Schottky circuitry reduces power consumption without sacrificing speed.

FK PACKAGE
(TOP VIEW)

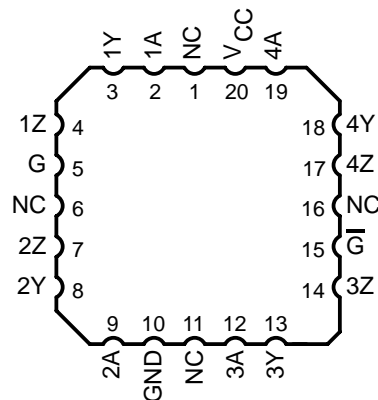

ORDERING INFORMATION

| T _A | PACKAGE† | | ORDERABLE PART NUMBER | TOP-SIDE MARKING |
|----------------|-----------|---------------|-----------------------|------------------|
| 0°C to 70°C | PDIP – N | Tube | AM26LS31CN | AM26LS31CN |
| | SOIC – D | Tube | AM26LS31CD | AM26LS31C |
| | | Tape and reel | AM26LS31CDR | |
| | SOP – NS | Tape and reel | AM26LS31CNSR | 26LS31 |
| | SSOP – DB | Tape and reel | AM26LS31CDBR | SA31C |
| –55°C to 125°C | CDIP – J | Tube | AM26LS31MJ | AM26LS31MJB |
| | LCCC – FK | Tube | AM26LS31MFK | AM26LS31MFKB |

† Package drawings, standard packing quantities, thermal data, symbolization, and PCB design guidelines are available at www.ti.com/sc/package.



Please be aware that an important notice concerning availability, standard warranty, and use in critical applications of Texas Instruments semiconductor products and disclaimers thereto appears at the end of this data sheet.

PRODUCTION DATA information is current as of publication date. Products conform to specifications per the terms of Texas Instruments standard warranty. Production processing does not necessarily include testing of all parameters.

 **TEXAS
INSTRUMENTS**

POST OFFICE BOX 655303 • DALLAS, TEXAS 75265

Copyright © 2002, Texas Instruments Incorporated
On products compliant to MIL-PRF-38535, all parameters are tested unless otherwise noted. On all other products, production processing does not necessarily include testing of all parameters.

AM26LS31C, AM26LS31M QUADRUPLE DIFFERENTIAL LINE DRIVER

SLLS114H – JANUARY 1979 – REVISED JULY 2002

FUNCTION TABLE
(each driver)

| INPUT A | ENABLES | | OUTPUTS | |
|------------|---------|----------------|---------|---|
| | G | \overline{G} | Y | Z |
| H | H | X | H | L |
| L | H | X | L | H |
| H | X | L | H | L |
| L | X | L | L | H |
| X | L | H | Z | Z |

H = high level, L = low level, X = irrelevant,
Z = high impedance (off)

logic diagram (positive logic)

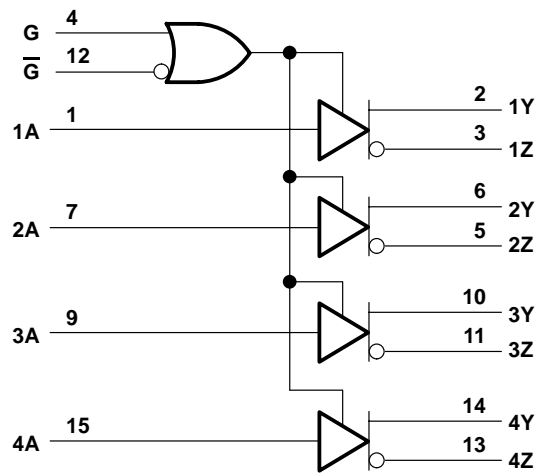

AM26LS31C, AM26LS31M QUADRUPLE DIFFERENTIAL LINE DRIVER

SLLS114H – JANUARY 1979 – REVISED JULY 2002

schematic (each driver)

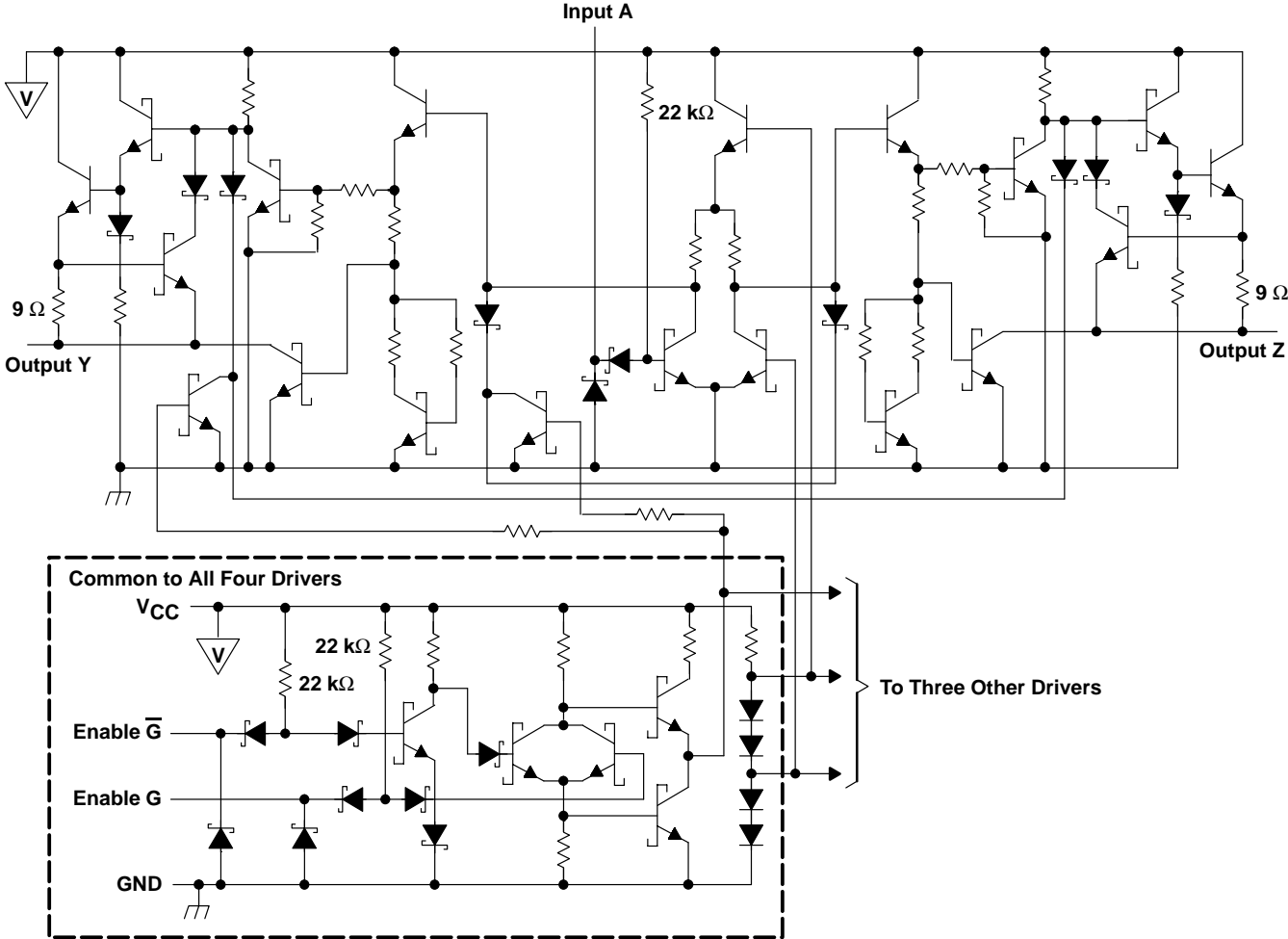

All resistor values are nominal.

AM26LS31C, AM26LS31M QUADRUPLE DIFFERENTIAL LINE DRIVER

SLLS114H – JANUARY 1979 – REVISED JULY 2002

absolute maximum ratings over operating free-air temperature range (unless otherwise noted)†

| | |
|-------------------------------------------------------------------------|----------------|
| Supply voltage, V_{CC} (see Note 1) | 7 V |
| Input voltage, V_I | 7 V |
| Output off-state voltage | 5.5 V |
| Package thermal impedance, θ_{JA} (see Note 2): D package | 73°C/W |
| DB package | 82°C/W |
| N package | 67°C/W |
| NS package | 64°C/W |
| Lead temperature 1,6 mm (1/16 inch) from case for 10 seconds | 260°C |
| Lead temperature 1,6 mm (1/16 inch) from case for 60 seconds: J package | 300°C |
| Storage temperature range, T_{stg} | -65°C to 150°C |

† Stresses beyond those listed under “absolute maximum ratings” may cause permanent damage to the device. These are stress ratings only, and functional operation of the device at these or any other conditions beyond those indicated under “recommended operating conditions” is not implied. Exposure to absolute-maximum-rated conditions for extended periods may affect device reliability.

- NOTES: 1. All voltage values, except differential output voltage V_{OD} , are with respect to network GND.
2. The package thermal impedance is calculated in accordance with JESD 51-7.

DISSIPATION RATING TABLE

| PACKAGE | $T_A \leq 25^\circ\text{C}$ POWER RATING | DERATING FACTOR ABOVE $T_A = 25^\circ\text{C}^\ddagger$ | $T_A = 70^\circ\text{C}$ POWER RATING | $T_A = 125^\circ\text{C}$ POWER RATING |
|---------|---------------------------------------------|------------------------------------------------------------|------------------------------------------|-------------------------------------------|
| FK | 1375 mW | 11.0 mW/°C | 880 mW | 275 mW |
| J | 1375 mW | 11.0 mW/°C | 880 mW | 275 mW |

‡ This is the inverse of the traditional junction-to-ambient thermal resistance ($R\theta_{JA}$). Thermal resistances are not production tested and the values given are for informational purposes only.

recommended operating conditions

| | | MIN | NOM | MAX | UNIT |
|--------------------------------------|-----------|------|-----|------|------|
| V_{CC} Supply voltage | AM26LS31C | 4.75 | 5 | 5.25 | V |
| | AM26LS31M | 4.5 | 5 | 5.5 | |
| V_{IH} High-level input voltage | | 2 | | | V |
| V_{IL} Low-level input voltage | | 0.8 | | | V |
| I_{OH} High-level output current | | -20 | | | mA |
| I_{OL} Low-level output current | | 20 | | | mA |
| T_A Operating free-air temperature | AM26LS31C | 0 | 70 | | °C |
| | AM26LS31M | -55 | 125 | | |



AM26LS31C, AM26LS31M QUADRUPLE DIFFERENTIAL LINE DRIVER

SLLS114H – JANUARY 1979 – REVISED JULY 2002

electrical characteristics over operating free-air temperature range (unless otherwise noted)†

| PARAMETER | | TEST CONDITIONS | | MIN | TYP‡ | MAX | UNIT |
|-----------------|-------------------------------------------------|----------------------------------------------------|-------------------------|-----|------|-------|------|
| V _{IK} | Input clamp voltage | V _{CC} = MIN, | I _I = -18 mA | | | -1.5 | V |
| V _{OH} | High-level output voltage | V _{CC} = MIN, I _{OH} = -20 mA | T _A = -55°C | 2.4 | | | V |
| | | | All other temperatures | 2.5 | | | |
| V _{OL} | Low-level output voltage | V _{CC} = MIN, | I _{OL} = 20 mA | | | 0.5 | V |
| I _{OZ} | Off-state (high-impedance-state) output current | V _{CC} = MIN | V _O = 0.5 V | | | -20 | μA |
| | | | V _O = 2.5 V | | | 20 | |
| I _I | Input current at maximum input voltage | V _{CC} = MAX, | V _I = 7 V | | | 0.1 | mA |
| I _{IH} | High-level input current | V _{CC} = MAX, | V _I = 2.7 V | | | 20 | μA |
| I _{IL} | Low-level input current | V _{CC} = MAX, | V _I = 0.4 V | | | -0.36 | mA |
| I _{OS} | Short-circuit output current§ | V _{CC} = MAX | | -30 | | -150 | mA |
| I _{CC} | Supply current | V _{CC} = MAX, | All outputs disabled | | 32 | 80 | mA |

† For C suffix devices, V_{CC} MIN = 4.75 V and V_{CC} MAX = 5.25 V. For M suffix devices, V_{CC} MIN = 4.5 V and V_{CC} MAX = 5.5 V.

‡ All typical values are at V_{CC} = 5 V and T_A = 25°C.

§ Not more than one output should be shorted at a time, and duration of the short circuit should not exceed one second.

switching characteristics, V_{CC} = 5 V, T_A = 25°C (see Figure 1)

| PARAMETER | | TEST CONDITIONS | | MIN | TYP | MAX | UNIT |
|------------------|--------------------------------------------------|-------------------------|------------------------|-----|-----|-----|------|
| t _{PLH} | Propagation delay time, low-to-high-level output | C _L = 30 pF, | S1 and S2 open | | 14 | 20 | ns |
| t _{PHL} | Propagation delay time, high-to-low-level output | | | | 14 | 20 | |
| t _{PZH} | Output enable time to high level | C _L = 30 pF | R _L = 75 Ω | | 25 | 40 | ns |
| t _{PZL} | Output enable time to low level | | R _L = 180 Ω | | 37 | 45 | |
| t _{PHZ} | Output disable time from high level | C _L = 10 pF, | S1 and S2 closed | | 21 | 30 | ns |
| t _{PLZ} | Output disable time from low level | | | | 23 | 35 | |
| | Output-to-output skew | C _L = 30 pF, | S1 and S2 open | | 1 | 6 | ns |



AM26LS31C, AM26LS31M QUADRUPLE DIFFERENTIAL LINE DRIVER

SLLS114H – JANUARY 1979 – REVISED JULY 2002

PARAMETER MEASUREMENT INFORMATION

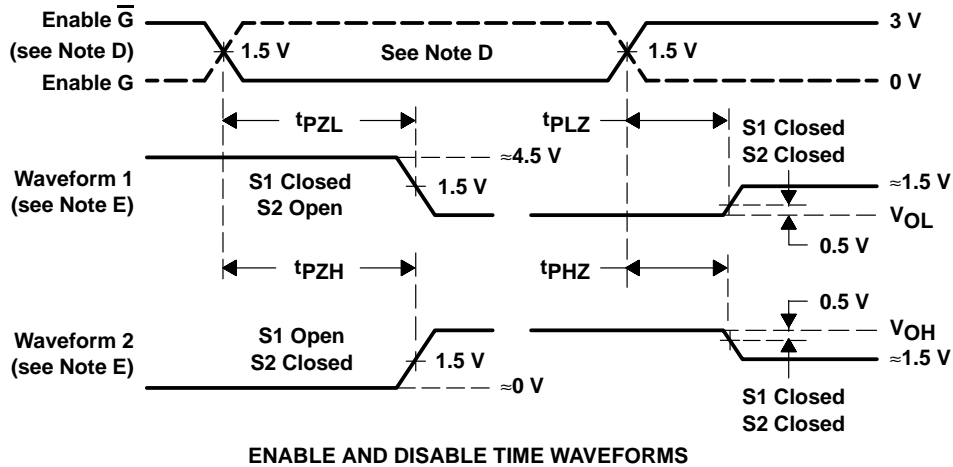
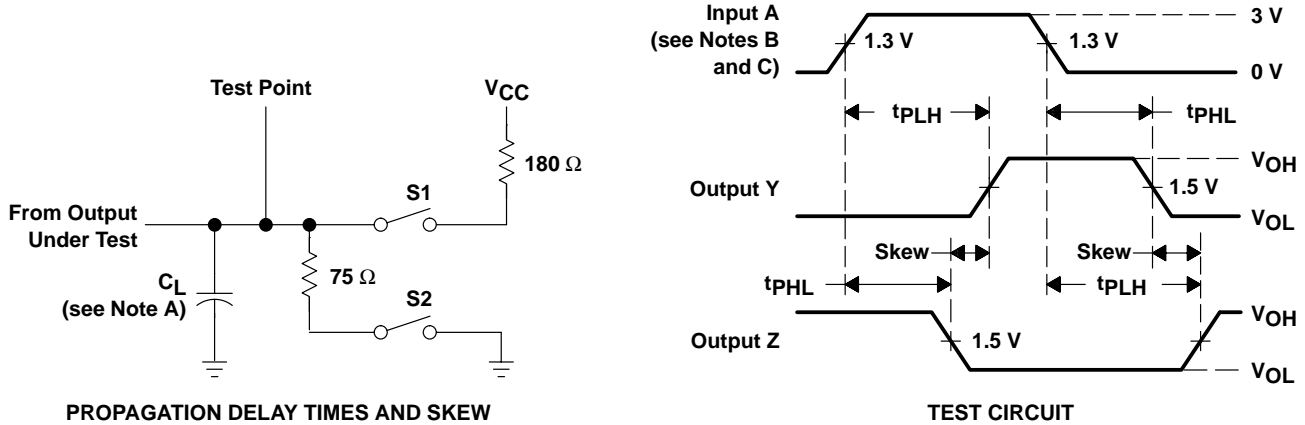

- NOTES:
- A. C_L includes probe and jig capacitance.
 - B. All input pulses are supplied by generators having the following characteristics: $PRR \leq 1$ MHz, $Z_O \approx 50 \Omega$, $t_r \leq 15$ ns, $t_f \leq 6$ ns.
 - C. When measuring propagation delay times and skew, switches S1 and S2 are open.
 - D. Each enable is tested separately.
 - E. Waveform 1 is for an output with internal conditions such that the output is low except when disabled by the output control. Waveform 2 is for an output with internal conditions such that the output is high except when disabled by the output control.

Figure 1. Test Circuit and Voltage Waveforms

TYPICAL CHARACTERISTICS

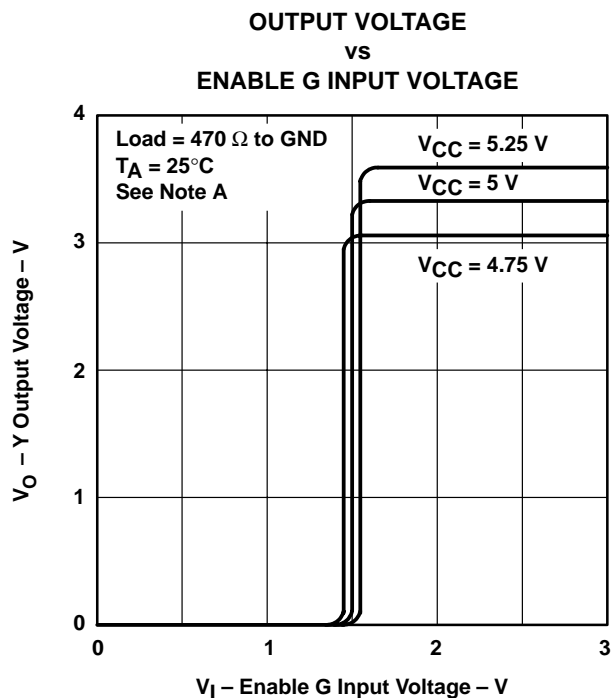

Figure 2

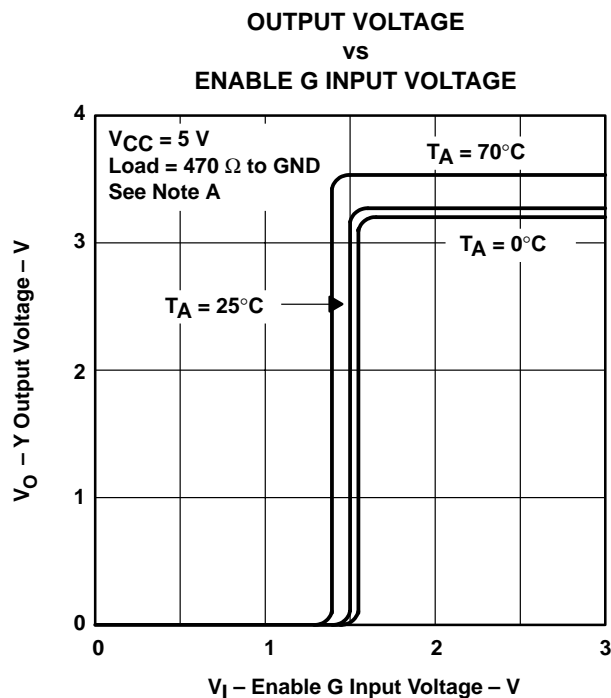

Figure 3

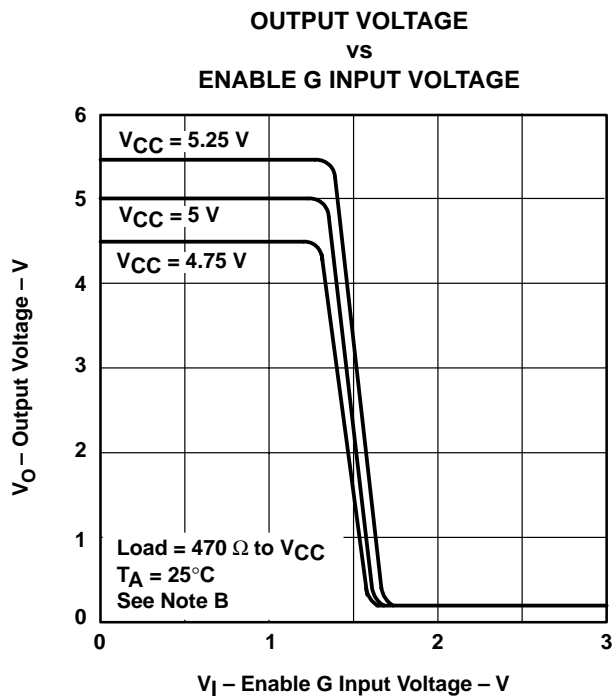

Figure 4

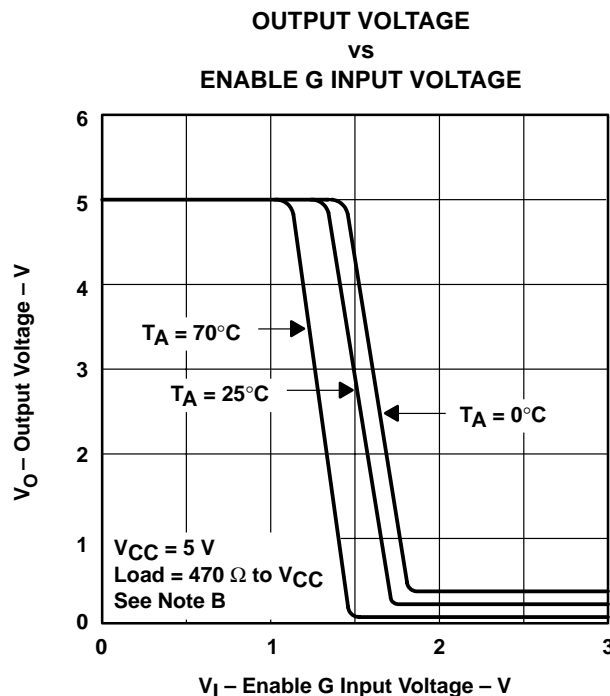

Figure 5

NOTES: A. The A input is connected to V_{CC} during testing of the Y outputs and to ground during testing of the Z outputs.
 B. The A input is connected to ground during testing of the Y outputs and to V_{CC} during testing of the Z outputs.

AM26LS31C, AM26LS31M QUADRUPLE DIFFERENTIAL LINE DRIVER

SLLS114H – JANUARY 1979 – REVISED JULY 2002

TYPICAL CHARACTERISTICS

HIGH-LEVEL OUTPUT VOLTAGE
vs
FREE-AIR TEMPERATURE

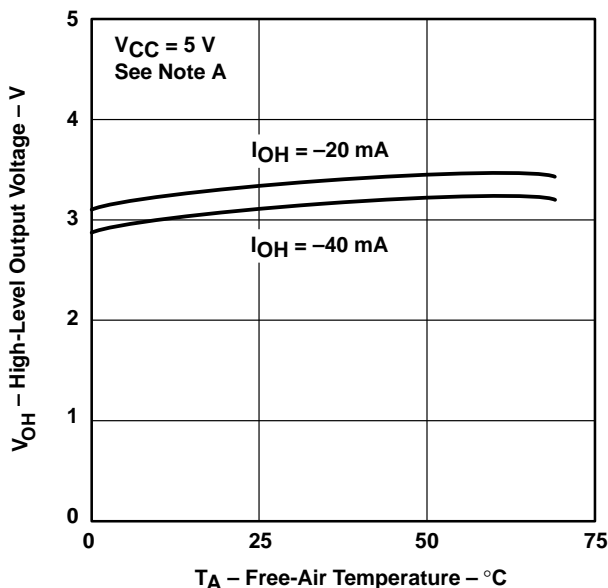

Figure 6

HIGH-LEVEL OUTPUT VOLTAGE
vs
HIGH-LEVEL OUTPUT CURRENT

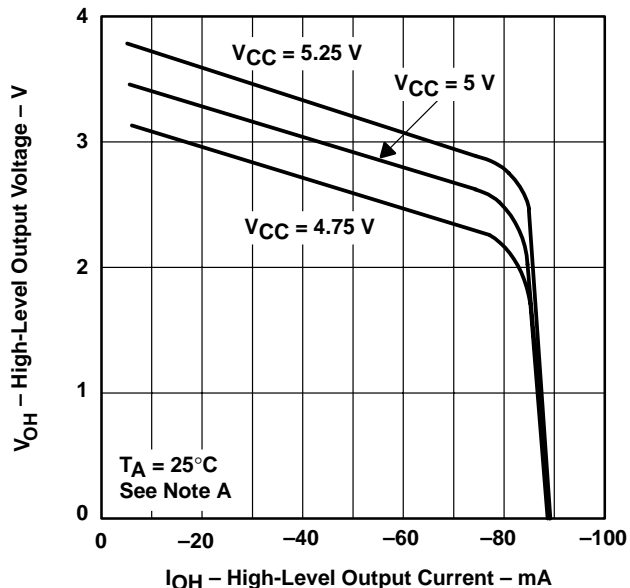

Figure 7

LOW-LEVEL OUTPUT VOLTAGE
vs
FREE-AIR TEMPERATURE

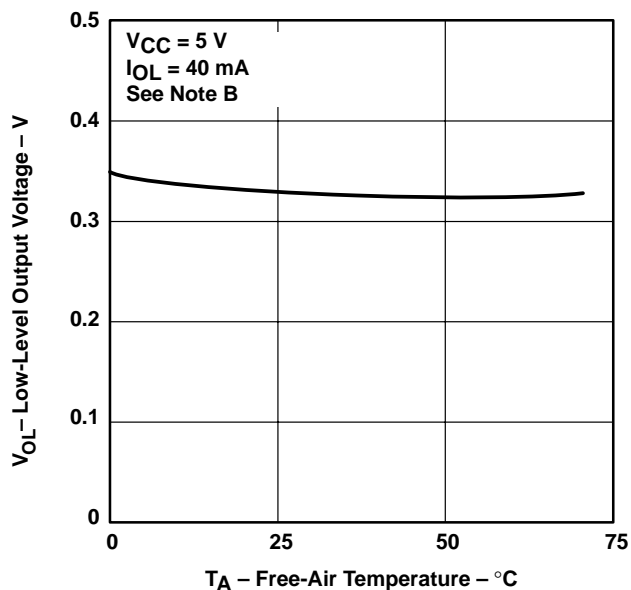

Figure 8

LOW-LEVEL OUTPUT VOLTAGE
vs
LOW-LEVEL OUTPUT CURRENT

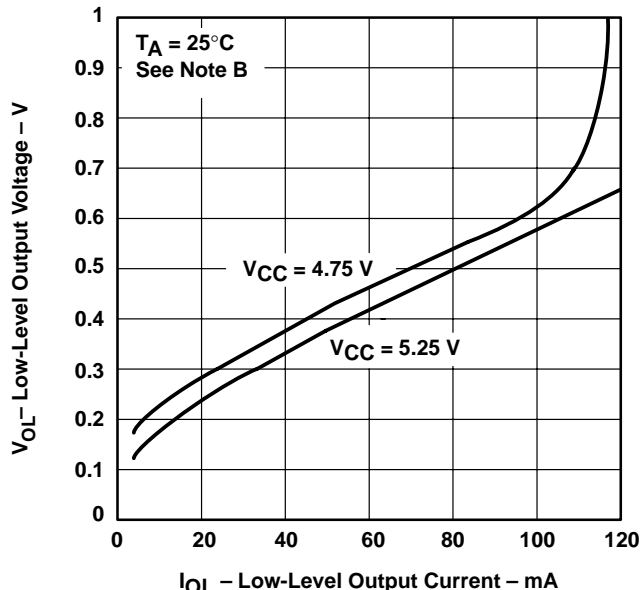
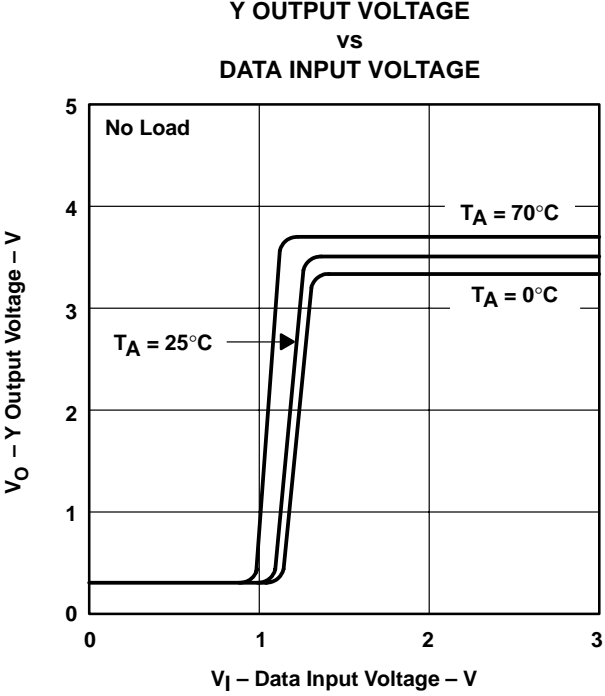
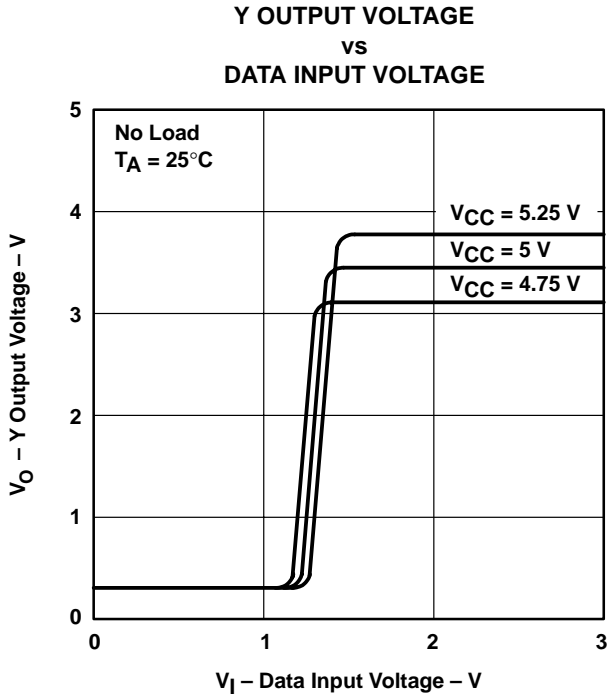

Figure 9

NOTES: A. The A input is connected to V_{CC} during testing of the Y outputs and to ground during testing of the Z outputs.
B. The A input is connected to ground during testing of the Y outputs and to V_{CC} during testing of the Z inputs.



TYPICAL CHARACTERISTICS



PACKAGING INFORMATION

| Orderable Device | Status ⁽¹⁾ | Package Type | Package Drawing | Pins | Package Qty | Eco Plan ⁽²⁾ | Lead/Ball Finish | MSL Peak Temp ⁽³⁾ |
|------------------|-----------------------|--------------|-----------------|------|-------------|-------------------------|------------------|--------------------------------------------|
| AM26LS31CD | ACTIVE | SOIC | D | 16 | 40 | Pb-Free (RoHS) | CU NIPDAU | Level-2-260C-1 YEAR/ Level-1-235C-UNLIM |
| AM26LS31CDBR | ACTIVE | SSOP | DB | 16 | 2000 | Pb-Free (RoHS) | CU NIPDAU | Level-2-260C-1 YEAR/ Level-1-235C-UNLIM |
| AM26LS31CDR | ACTIVE | SOIC | D | 16 | 2500 | Pb-Free (RoHS) | CU NIPDAU | Level-2-260C-1 YEAR/ Level-1-235C-UNLIM |
| AM26LS31CN | ACTIVE | PDIP | N | 16 | 25 | Pb-Free (RoHS) | CU NIPDAU | Level-NC-NC-NC |
| AM26LS31CNSR | ACTIVE | SO | NS | 16 | 2000 | Pb-Free (RoHS) | CU NIPDAU | Level-2-260C-1 YEAR/ Level-1-235C-UNLIM |

⁽¹⁾ The marketing status values are defined as follows:

ACTIVE: Product device recommended for new designs.

LIFEBUY: TI has announced that the device will be discontinued, and a lifetime-buy period is in effect.

NRND: Not recommended for new designs. Device is in production to support existing customers, but TI does not recommend using this part in a new design.

PREVIEW: Device has been announced but is not in production. Samples may or may not be available.

OBSOLETE: TI has discontinued the production of the device.

⁽²⁾ Eco Plan - May not be currently available - please check <http://www.ti.com/productcontent> for the latest availability information and additional product content details.

None: Not yet available Lead (Pb-Free).

Pb-Free (RoHS): TI's terms "Lead-Free" or "Pb-Free" mean semiconductor products that are compatible with the current RoHS requirements for all 6 substances, including the requirement that lead not exceed 0.1% by weight in homogeneous materials. Where designed to be soldered at high temperatures, TI Pb-Free products are suitable for use in specified lead-free processes.

Green (RoHS & no Sb/Br): TI defines "Green" to mean "Pb-Free" and in addition, uses package materials that do not contain halogens, including bromine (Br) or antimony (Sb) above 0.1% of total product weight.

⁽³⁾ MSL, Peak Temp. -- The Moisture Sensitivity Level rating according to the JEDEC industry standard classifications, and peak solder temperature.

Important Information and Disclaimer: The information provided on this page represents TI's knowledge and belief as of the date that it is provided. TI bases its knowledge and belief on information provided by third parties, and makes no representation or warranty as to the accuracy of such information. Efforts are underway to better integrate information from third parties. TI has taken and continues to take reasonable steps to provide representative and accurate information but may not have conducted destructive testing or chemical analysis on incoming materials and chemicals. TI and TI suppliers consider certain information to be proprietary, and thus CAS numbers and other limited information may not be available for release.

In no event shall TI's liability arising out of such information exceed the total purchase price of the TI part(s) at issue in this document sold by TI to Customer on an annual basis.

N (R-PDIP-T**)

PLASTIC DUAL-IN-LINE PACKAGE

16 PINS SHOWN



- NOTES:
- A. All linear dimensions are in inches (millimeters).
 - B. This drawing is subject to change without notice.
 - $\triangle C$ Falls within JEDEC MS-001, except 18 and 20 pin minimum body length (Dim A).
 - $\triangle D$ The 20 pin end lead shoulder width is a vendor option, either half or full width.

4040049/E 12/2002

D (R-PDSO-G16)

PLASTIC SMALL-OUTLINE PACKAGE



- NOTES:
- A. All linear dimensions are in inches (millimeters).
 - B. This drawing is subject to change without notice.
 - C. Body dimensions do not include mold flash or protrusion not to exceed 0.006 (0,15).
 - D. Falls within JEDEC MS-012 variation AC.

MECHANICAL DATA

NS (R-PDSO-G**)

PLASTIC SMALL-OUTLINE PACKAGE

14-PINS SHOWN



- NOTES:
- A. All linear dimensions are in millimeters.
 - B. This drawing is subject to change without notice.
 - C. Body dimensions do not include mold flash or protrusion, not to exceed 0,15.

DB (R-PDSO-G**)

PLASTIC SMALL-OUTLINE

28 PINS SHOWN



- NOTES: A. All linear dimensions are in millimeters.
 B. This drawing is subject to change without notice.
 C. Body dimensions do not include mold flash or protrusion not to exceed 0,15.
 D. Falls within JEDEC MO-150

IMPORTANT NOTICE

Texas Instruments Incorporated and its subsidiaries (TI) reserve the right to make corrections, modifications, enhancements, improvements, and other changes to its products and services at any time and to discontinue any product or service without notice. Customers should obtain the latest relevant information before placing orders and should verify that such information is current and complete. All products are sold subject to TI's terms and conditions of sale supplied at the time of order acknowledgment.

TI warrants performance of its hardware products to the specifications applicable at the time of sale in accordance with TI's standard warranty. Testing and other quality control techniques are used to the extent TI deems necessary to support this warranty. Except where mandated by government requirements, testing of all parameters of each product is not necessarily performed.

TI assumes no liability for applications assistance or customer product design. Customers are responsible for their products and applications using TI components. To minimize the risks associated with customer products and applications, customers should provide adequate design and operating safeguards.

TI does not warrant or represent that any license, either express or implied, is granted under any TI patent right, copyright, mask work right, or other TI intellectual property right relating to any combination, machine, or process in which TI products or services are used. Information published by TI regarding third-party products or services does not constitute a license from TI to use such products or services or a warranty or endorsement thereof. Use of such information may require a license from a third party under the patents or other intellectual property of the third party, or a license from TI under the patents or other intellectual property of TI.

Reproduction of information in TI data books or data sheets is permissible only if reproduction is without alteration and is accompanied by all associated warranties, conditions, limitations, and notices. Reproduction of this information with alteration is an unfair and deceptive business practice. TI is not responsible or liable for such altered documentation.

Resale of TI products or services with statements different from or beyond the parameters stated by TI for that product or service voids all express and any implied warranties for the associated TI product or service and is an unfair and deceptive business practice. TI is not responsible or liable for any such statements.

Following are URLs where you can obtain information on other Texas Instruments products and application solutions:

| Products | | Applications | |
|------------------|--------------------------------------------------------------------|---------------------|--------------------------------------------------------------------------|
| Amplifiers | amplifier.ti.com | Audio | www.ti.com/audio |
| Data Converters | dataconverter.ti.com | Automotive | www.ti.com/automotive |
| DSP | dsp.ti.com | Broadband | www.ti.com/broadband |
| Interface | interface.ti.com | Digital Control | www.ti.com/digitalcontrol |
| Logic | logic.ti.com | Military | www.ti.com/military |
| Power Mgmt | power.ti.com | Optical Networking | www.ti.com/opticalnetwork |
| Microcontrollers | microcontroller.ti.com | Security | www.ti.com/security |
| | | Telephony | www.ti.com/telephony |
| | | Video & Imaging | www.ti.com/video |
| | | Wireless | www.ti.com/wireless |

Mailing Address: Texas Instruments
Post Office Box 655303 Dallas, Texas 75265