



Y2K-Enhanced Real-Time Clock (RTC)

Features

- ACPI-compliant day-of-month alarm
- Y2K century bit
- Direct clock/calendar replacement for IBM® AT-compatible computers and other applications
- 2 index shadow registers
- 2.7–5.5V operation
- 240 bytes of general nonvolatile storage
- Dedicated 32.768kHz output pin
- System wake-up capability—alarm interrupt output active in battery-backup mode
- Less than 0.55µA load under battery operation
- Selectable Intel or Motorola bus timing
- 24-pin plastic SSOP

General Description

The CMOS bq3285LF is a low-power microprocessor peripheral providing a time-of-day clock and 100-year calendar with alarm features and battery operation. The architecture is based on the bq3285 RTC with added features: century bit, low-voltage operation, 32.768kHz output, 126 additional bytes of CMOS, two shadow registers of last address used, and a day-of-month alarm to be compliant with the ACPI RTC specification.

A 32.768kHz output is available for sustaining power-management activities. The bq3285LF 32kHz output is always on whenever V_{CC} is valid. In V_{CC} standby mode, the 32kHz is active, and the bq3285LF typically draws 100µA. Wake-up capability is provided by an alarm interrupt, which is active in battery-backup mode. In battery-backup mode, current drain is less than 550nA.

The bq3285LF write-protects the clock, calendar, and storage registers during power failure. A backup battery then maintains data and operates the clock and calendar.

The bq3285LF is a fully compatible real-time clock for IBM AT-compatible computers and other applications. The only external components are a 32.768kHz crystal and a backup battery.

The bq3285LF is intended for use in 3V systems; however, it may also operate at 5V and then go into a 3V power-down state, write-protecting as if in a 3V system.

Pin Connections

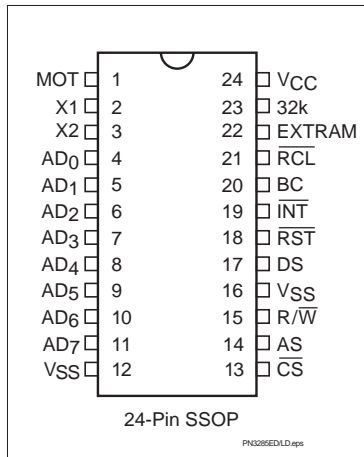

Pin Names

AD ₀ –AD ₇	Multiplexed address/data input/output	32K	32.768kHz output
MOT	Bus type select input	EXTRAM	Extended RAM enable
$\overline{\text{CS}}$	Chip select input	RCL	RAM clear input
AS	Address strobe input	BC	3V backup cell input
DS	Data strobe input	X1–X2	Crystal inputs
$\overline{\text{R/W}}$	Read/write input	V _{CC}	Supply voltage input
$\overline{\text{INT}}$	Interrupt request output	V _{SS}	Ground
RST	Reset input		

bq3285LF

Block Diagram

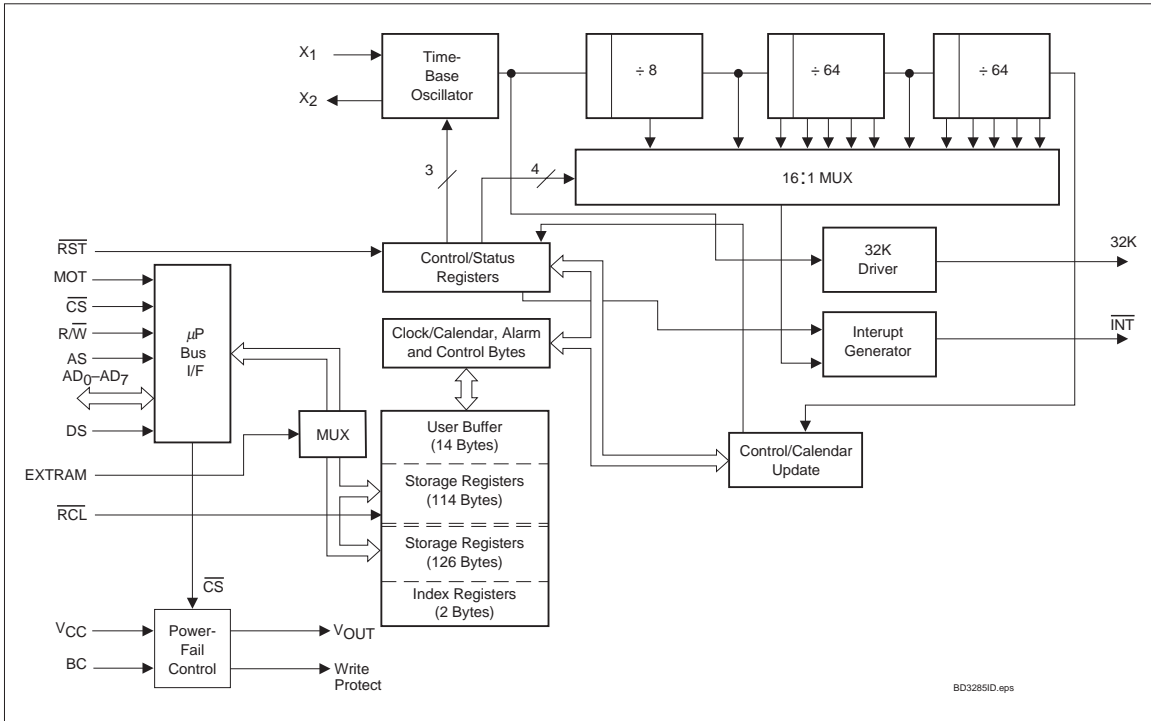

Pin Descriptions

MOT Bus type select input

MOT selects bus timing for either Motorola or Intel architecture. This pin should be tied to V_{CC} for Motorola timing or to V_{SS} for Intel timing (see Table 1). The setting should not be changed during system operation. MOT is internally pulled low by a 30K Ω resistor.

Table 1. Bus Setup

Bus Type	MOT Level	DS Equivalent	R/W Equivalent	AS Equivalent
Motorola	V _{CC}	DS, E, or φ ₂	R/W	AS
Intel	V _{SS}	R _D , MEMR, or I/OR	W _R , MEMW, or I/OW	ALE

AD₀-AD₇ Multiplexed address/data input/output

The bq3285LF bus cycle consists of two phases: the address phase and the data-transfer phase. The address phase precedes the data-transfer phase. During the address phase, an address placed on AD₀-AD₇ is latched into the bq3285LF on the falling edge of the AS signal. During the data-transfer phase of the bus cycle, the AD₀-AD₇ pins serve as a bidirectional data bus.

AS Address strobe input

AS serves to demultiplex the address/data bus. The falling edge of AS latches the address on AD₀-AD₇. This demultiplexing process is independent of the CS signal. For DIP and SOIC packages with MOT = V_{SS}, the AS input is provided a signal similar to ALE in an Intel-based system.

A low input on EXTRAM during the falling edge of AS latches the address into standard bank address latch. A high input on the EXTRAM input during the falling edge of AS latches the address into the extended bank address latch. The contents of the address latches are copied into the standard bank index and the extended bank index registers respectively. EXTRAM is not latched.

DS Data strobe input

When MOT = V_{CC}, DS controls data transfer during a bq3285LF bus cycle. During a read cycle, the bq3285LF drives the bus after the rising edge on DS. During a write cycle, the falling edge on DS is used to latch write data into the chip.

When MOT = V_{SS}, the DS input is provided a signal similar to RD, MEMR, or I/OR in an Intel-based system. The falling edge on DS is used to enable the outputs during a read cycle.

The state of the EXTRAM input selects the address latch used during data access. A low input on EXTRAM selects the standard bank latch and the location in the standard bank pointed to by the value in this latch. A high input on the EXTRAM selects the extended bank latch and the location in the extended bank pointed to by the value in this latch.

R/W Read/write input

When MOT = V_{CC}, the level on R/W identifies the direction of data transfer. A high level on R/W indicates a read bus cycle, whereas a low on this pin indicates a write bus cycle.

When MOT = V_{SS}, R/W is provided a signal similar to WR, MEMW, or I/OW in an Intel-based system. The rising edge on R/W latches data into the bq3285LF.

CS Chip select input

CS should be driven low and held stable during the data-transfer phase of a bus cycle accessing the bq3285LF.

INT

Interrupt request output

INT is an open-drain output. This allows alarm INT to be valid in battery-backup mode. To use this feature, connect INT through a resistor to a power supply other than V_{CC}. INT is asserted low when any event flag is set and the corresponding event enable bit is also set. INT becomes high-impedance whenever register C is read (see the Control/Status Registers section).

32K

32.768 kHz output

32K provides a buffered 32.768 kHz output. The frequency remains on and fixed at 32.768kHz as long as V_{CC} is valid.

EXTRAM Extended RAM enable

Enables 128 bytes of additional nonvolatile SRAM. It is connected internally to a 30kΩ pull-down resistor. To access the RTC registers, EXTRAM must be low.

The input on this pin also selects the latch to be used in the data transfer. A low value selects the standard bank latch. A high value selects the extended the bank latch. EXTRAM should be valid for complete address, read or write cycle.

RCL

RAM clear input

A low level on the RCL pin causes the contents of each of the 240 storage bytes to be set to FF(hex). RCL clears the shadow index registers to 00(hex). The contents of the clock and control registers are unaffected. This pin should be used as a user-interface input (pushbutton to ground) and not connected to the output of any active component. RCL input is only recognized when held low for at least 125ms in the presence of V_{CC}. Using RAM clear does not affect the battery load. This pin is connected internally to a 30kΩ pull-up resistor.

BC

3V backup cell input

BC should be connected to a 3V backup cell for RTC operation and storage register nonvolatility in the absence of system power. When V_{CC} slews down past V_{BC} (3V typical), the integral control circuitry switches the power source to BC. When V_{CC} returns above V_{BC}, the power source is switched to V_{CC}.

On power-up, a voltage within the V_{BC} range must be present on the BC pin for the oscillator to start up.

bq3285LF

$\overline{\text{RST}}$ Reset input

The bq3285LF is reset when $\overline{\text{RST}}$ is pulled low. When reset, $\overline{\text{INT}}$ becomes high impedance, and the bq3285LF is not accessible. Table 4 in the Control/Status Registers section lists the register bits that are cleared by a reset.

Reset may be disabled by connecting $\overline{\text{RST}}$ to V_{CC} . This allows the control bits to retain their states through power-down/power-up cycles.

X1–X2 Crystal inputs

The X1–X2 inputs are provided for an external 32.768kHz quartz crystal, Daiwa DT-26 or equivalent, with 6pF load capacitance. A trimming capacitor may be necessary for extremely precise time-base generation.

In the absence of a crystal, a 32.768kHz waveform can be fed into the X1 input.

Functional Description

Address Map

The bq3285LF provides 14 bytes of clock and control/status registers and 242 bytes of general nonvolatile storage. Figure 1 illustrates the address map for the bq3285LF.

Update Period

The update period for the bq3285LF is one second. The bq3285LF updates the contents of the clock and calendar locations during the update cycle at the end of each update period (see Figure 2). The alarm flag bit may also be set during the update cycle.

The bq3285LF copies the local register updates into the user buffer accessed by the host processor. When a 1 is written to the update transfer inhibit bit (UTI) in register B, the user copy of the clock and calendar bytes re-

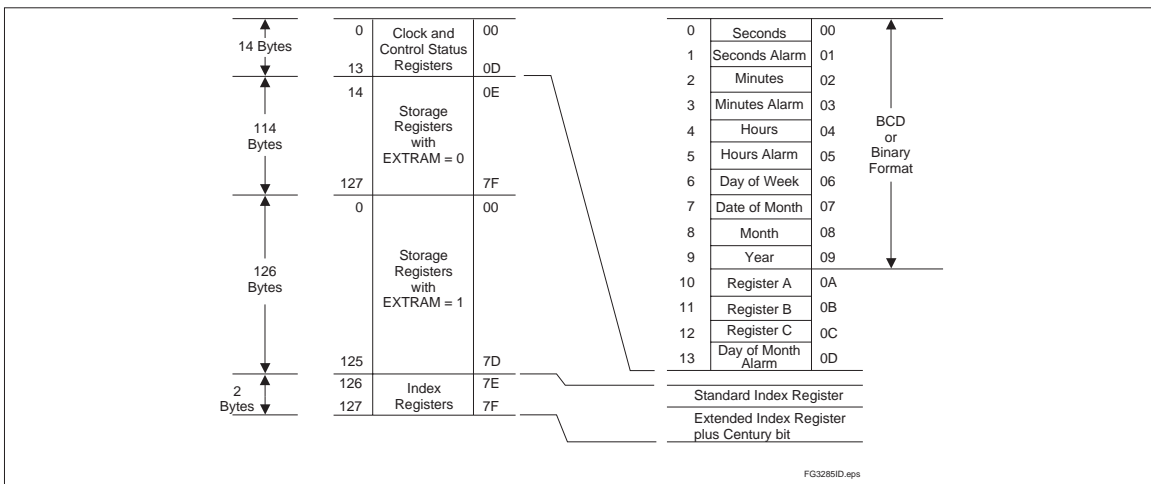

Figure 1. Address Map

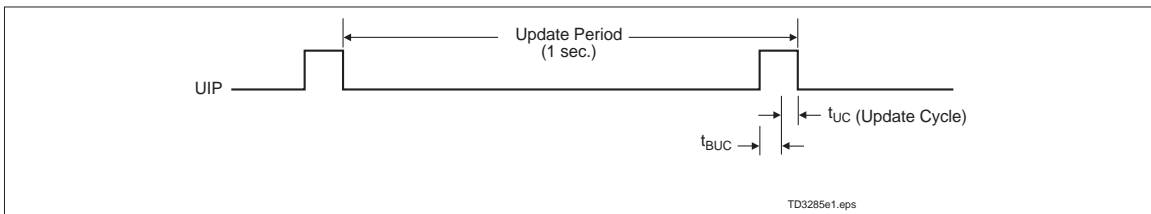

Figure 2. Update Period Timing and UIP

mains unchanged, while the local copy of the same bytes continues to be updated every second.

The update-in-progress bit (UIP) in register A is set t_{BUC} time before the beginning of an update cycle (see Figure 2). This bit is cleared and the update-complete flag (UF) is set at the end of the update cycle.

Programming the RTC

The time-of-day, alarm, and calendar bytes can be written in either the BCD or binary format (see Table 2).

These steps may be followed to program the time, alarm, and calendar:

1. Modify the contents of register B:
 - a. Write a 1 to the UTI bit to prevent transfers between RTC bytes and user buffer.
 - b. Write the appropriate value to the data format (DF) bit to select BCD or binary format for all time, alarm, and calendar bytes.
 - c. Write the appropriate value to the hour format (HF) bit.
2. Write new values to all the time, alarm, and calendar locations.
3. The CENT bit in location 7Fh (bit 7) of the extended SRAM bank is read only. Writing year in location 09h automatically updates CENT.
4. Clear the UTI bit to allow update transfers.

Table 2. Time, Alarm, Calendar, and Index Formats

Address	RTC Bytes	Range		
		Decimal	Binary	Binary-Coded Decimal
0	Seconds	0–59	00H–3BH	00H–59H
1	Seconds alarm	0–59	00H–3BH	00H–59H
2	Minutes	0–59	00H–3BH	00H–59H
3	Minutes alarm	0–59	00H–3BH	00H–59H
4	Hours, 12-hour format	1–12	01H–0CH AM; 81H–8CH PM	01H–12H AM; 81H–92H PM
	Hours, 24-hour format	0–23	00H–17H	00H–23H
5	Hours alarm, 12-hour format	1–12	01H–0CH AM; 81H–8CH PM	01H–12H AM; 81H–92H PM
	Hours alarm, 24-hour format	0–23	00H–17H	00H–23H
6	Day of week (1=Sunday)	1–7	01H–07H	01H–07H
7	Day of month	1–31	01H–1FH	01H–31H
8	Month	1–12	01H–0CH	01H–12H
9	Year (see note)	0–99	00H–63H	00H–99H
D	Day of month alarm	1–31	01H–1FH	01–31H

Note: Century for “Year” is shown in location 7Fh (Extended Index Register, bit 7) .

bq3285LF

On the next update cycle, the RTC updates all 10 bytes in the selected format.

32kHz Output

The bq3285LF provides for a 32.768kHz output, and the output is always active whenever V_{CC} is valid (V_{PPFD} + t_{CSR}). The bq3285LF output is not affected by the bit settings in Register A. Time-keeping aspects, however, still require setting OS0-OS2.

Interrupts

The bq3285LF allows three individually selected interrupt events to generate an interrupt request. These three interrupt events are:

- The periodic interrupt, programmable to occur once every 122μs to 500ms.
- The alarm interrupt, programmable to occur once per second to once per day, is active in battery-backup mode, providing a “wake-up” feature.
- The update-ended interrupt, which occurs at the end of each update cycle.

Each of the three interrupt events is enabled by an individual interrupt-enable bit in register B. When an event occurs, its event flag bit in register C is set. If the corresponding event enable bit is also set, then an interrupt request is generated. The interrupt request flag bit (INTF) of register C is set with every interrupt request. Reading register C clears all flag bits, including INTF, and makes INT high-impedance.

Two methods can be used to process bq3285LF interrupt events:

- Enable interrupt events and use the interrupt request output to invoke an interrupt service routine.
- Do not enable the interrupts and use a polling routine to periodically check the status of the flag bits.

The individual interrupt sources are described in detail in the following sections.

Periodic Interrupt

If the periodic interrupt event is enabled by writing a 1 to the periodic interrupt enable bit (PIE) in register C, an interrupt request is generated once every 122μs to 500ms. The period between interrupts is selected with bits RS3-RS0 in register A (see Table 3).

Table 3. Periodic Interrupt Rate

Register A Bits							Periodic Interrupt	
OSC2	OSC1	OSC0	RS3	RS2	RS1	RS0	Period	Units
0	1	0	0	0	0	0	None	
0	1	0	0	0	0	1	3.90625	ms
0	1	0	0	0	1	0	7.8125	ms
0	1	0	0	0	1	1	122.070	μs
0	1	0	0	1	0	0	244.141	μs
0	1	0	0	1	0	1	488.281	μs
0	1	0	0	1	1	0	976.5625	μs
0	1	0	0	1	1	1	1.95315	ms
0	1	0	1	0	0	0	3.90625	ms
0	1	0	1	0	0	1	7.8125	ms
0	1	0	1	0	1	0	15.625	ms
0	1	0	1	0	1	1	31.25	ms
0	1	0	1	1	0	0	62.5	ms
0	1	0	1	1	0	1	125	ms
0	1	0	1	1	1	0	250	ms
0	1	0	1	1	1	1	500	ms
0	1	1	X	X	X	X	same as above defined by RS3-RS0	

Alarm Interrupt

The alarm interrupt is active in battery-backup mode, providing a “wake-up” capability. During each update cycle, the RTC compares the day-of-the-month, hours, minutes, and seconds bytes with the four corresponding alarm bytes. If a match of all bytes is found, the alarm interrupt event flag bit, AF in register C, is set to 1. If the alarm event is enabled, an interrupt request is generated.

An alarm byte may be removed from the comparison by setting it to a “don't care” state. The seconds, minutes, and hours alarm bytes are set to a “don't care” state by writing a 1 to each of its two most-significant bits. The day-of-the-month alarm byte is set to a “don't care” state by setting DA5–DA0, in register D, to all zeros. A “don't care” state may be used to select the frequency of alarm interrupt events as follows:

- If none of the four alarm bytes is “don't care,” the frequency is once per month, when day-of-the-month, hours, minutes, and seconds match.
- If only the day-of-the-month alarm byte is “don't care,” the frequency is once per day, when hours, minutes, and seconds match.
- If only the day-of-the-month and hour alarm byte is “don't care,” the frequency is once per hour, when minutes and seconds match.
- If only the day-of-the-month, hour and minute alarm bytes are “don't care,” the frequency is once per minute, when seconds match.
- If the day-of-the-month, hour, minute, and second alarm bytes are “don't care,” the frequency is once per second.

Update Cycle Interrupt

The update cycle ended flag bit (UF) in register C is set to a 1 at the end of an update cycle. If the update interrupt enable bit (UIE) of register B is 1, and the update transfer

inhibit bit (UTI) in register B is 0, then an interrupt request is generated at the end of each update cycle.

Accessing RTC bytes

The EXTRAM pin must be low to access the RTC registers. Time and calendar bytes read during an update cycle may be in error. Three methods to access the time and calendar bytes without ambiguity are:

- Enable the update interrupt event to generate interrupt requests at the end of the update cycle. The interrupt handler has a maximum of 999ms to access the clock bytes before the next update cycle begins (see Figure 3).
- Poll the update-in-progress bit (UIP) in register A. If UIP = 0, the polling routine has a minimum of t_{BUC} time to access the clock bytes (see Figure 3).
- Use the periodic interrupt event to generate interrupt requests every t_{PI} time, such that UIP = 1 always occurs between the periodic interrupts. The interrupt handler has a minimum of t_{PI}/2 + t_{BUC} time to access the clock bytes (see Figure 3).

Oscillator Control

When power is first applied to the bq3285LF and V_{CC} is above V_{PPD}, the internal oscillator and frequency divider are turned on by writing a 010 pattern to bits 4 through 6 of register A. A pattern of 11X turns the oscillator on but keeps the frequency divider disabled. Any other pattern to these bits keeps the oscillator off. A pattern of 010 must be set for the bq3285LF to keep time in battery backup mode.

Power-Down/Power-Up Cycle

The bq3285LF continuously monitors V_{CC} for out-of-tolerance. During a power failure, when V_{CC} falls below

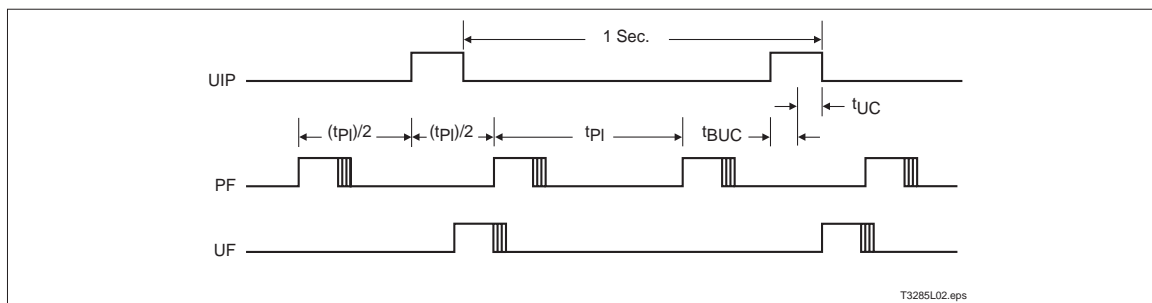

Figure 3. Update-Ended/Periodic Interrupt Relationship

bq3285LF

V_{PPFD} (2.53V typical), the bq3285LF write-protects the clock and storage registers. The power source is switched to BC when V_{CC} is less than V_{PPFD} and BC is greater than V_{PPFD}, or when V_{CC} is less than V_{BC} and V_{BC} is less than V_{PPFD}. RTC operation and storage data are sustained by a valid backup energy source. When V_{CC} is above V_{PPFD}, the power source is V_{CC}. Write-protection continues for t_{CSR} time after V_{CC} rises above V_{PPFD}.

Control/Status Registers

The four control/status registers of the bq3285LF are accessible regardless of the status of the update cycle (see Table 4).

Register A

Register A Bits							
7	6	5	4	3	2	1	0
UIP	OS2	OS1	OS0	RS3	RS2	RS1	RS0

Register A programs:

- The frequency of the periodic event rate.
- Oscillator operation.
- Time-keeping

Register A provides:

- Status of the update cycle.

RS0–RS3 - Frequency Select

7	6	5	4	3	2	1	0
-	-	-	-	RS3	RS2	RS1	RS0

These bits select the periodic interrupt rate, as shown in Table 3.

OS0–OS2 - Oscillator Control

7	6	5	4	3	2	1	0
-	OS2	OS1	OS0	-	-	-	-

These three bits control the state of the oscillator and divider stages. A pattern of 010 or 011 enables RTC operation by turning on the oscillator and enabling the frequency divider. This pattern must be set to turn the oscillator on and to ensure that the bq3285LF keeps time in battery-backup mode. A pattern of 11X turns the oscillator on, but keeps the frequency divider disabled. When 010 is written, the RTC begins its first update after 500ms.

UIP - Update Cycle Status

7	6	5	4	3	2	1	0
UIP	-	-	-	-	-	-	-

This read-only bit is set prior to the update cycle. When UIP equals 1, an RTC update cycle may be in progress. UIP is cleared at the end of each update cycle. This bit is also cleared when the update transfer inhibit (UTI) bit in register B is 1.

Table 4. Control/Status/Index Registers

Reg.	Loc. (Hex)	Read	Write	Bit Name and State on Reset															
				7 (MSB)		6		5		4		3		2		1		0 (LSB)	
A	0A	Yes	Yes ¹	UIP	na	OS2	na	OS1	na	OS0	na	RS3	na	RS2	na	RS1	na	RS0	na
B	0B	Yes	Yes	UTI	na	PIE	0	AIE	0	UIE	0	-	0	DF	na	HF	na	DSE	na
C	0C	Yes	No	INTF	0	PF	0	AF	0	UF	0	-	0	-	na	-	0	-	0
D	0D	Yes	Yes ²	VRT	na	-	0	DA5	na	DA4	na	DA3	na	DA2	na	DA1	na	DA0	na
SI	7E	Yes	No	NMI	0	SI6	0	SI5	0	SI4	0	SI3	0	SI2	0	SI1	0	SI0	0
EI	7F	Yes	No	CENT	0	EI6	0	EI5	0	EI4	0	EI3	0	EI2	0	EI1	0	EI0	0

- Notes:**
- na = not affected.
 - x = unknown
 - 1. Except bit 7.
 - 2. Except bits 6 and 7.

Register B

Register B Bits							
7	6	5	4	3	2	1	0
UTI	PIE	AIE	UIE	-	DF	HF	DSE

Register B enables:

- Update cycle transfer operation
- Interrupt events
- Daylight saving adjustment

Register B selects:

- Clock and calendar data formats

All bits of register B are read/write.

Bit 3 is unused.

DSE - Daylight Saving Enable

7	6	5	4	3	2	1	0
-	-	-	-	-	-	-	DSE

This bit enables daylight-saving time adjustments when written to 1:

- On the last Sunday in October, the first time the bq3285LF increments past 1:59:59 AM, the time falls back to 1:00:00 AM.
- On the first Sunday in April, the time springs forward from 2:00:00 AM to 3:00:00 AM.

HF - Hour Format

7	6	5	4	3	2	1	0
-	-	-	-	-	-	HF	-

This bit selects the time-of-day and alarm hour format:

- 1 = 24-hour format
- 0 = 12-hour format

DF - Data Format

7	6	5	4	3	2	1	0
-	-	-	-	-	DF	-	-

This bit selects the numeric format in which the time, alarm, and calendar bytes are represented:

- 1 = Binary
- 0 = BCD

UIE - Update Cycle Interrupt Enable

7	6	5	4	3	2	1	0
-	-	-	UIE	-	-	-	-

This bit enables an interrupt request due to an update ended interrupt event:

- 1 = Enabled
- 0 = Disabled

The UIE bit is automatically cleared when the UTI bit equals 1.

AIE - Alarm Interrupt Enable

7	6	5	4	3	2	1	0
-	-	AIE	-	-	-	-	-

This bit enables an interrupt request due to an alarm interrupt event:

- 1 = Enabled
- 0 = Disabled

PIE - Periodic Interrupt Enable

7	6	5	4	3	2	1	0
-	PIE	-	-	-	-	-	-

This bit enables an interrupt request due to a periodic interrupt event:

- 1 = Enabled
- 0 = Disabled

UTI - Update Transfer Inhibit

7	6	5	4	3	2	1	0
UTI	-	-	-	-	-	-	-

This bit inhibits the transfer of RTC bytes to the user buffer:

- 1 = Inhibits transfer and clears UIE
- 0 = Allows transfer

Register C

Register C Bits							
7	6	5	4	3	2	1	0
INTF	PF	AF	UF	0	-	0	0

Register C is the read-only event status register.

bq3285LF

Bits 0, 1, 2, 3 - Unused Bits

7	6	5	4	3	2	1	0
-	-	-	-	0	-	0	0

These bits are always set to 0.

UF - Update Event Flag

7	6	5	4	3	2	1	0
-	-	-	UF	-	-	-	-

This bit is set to a 1 at the end of the update cycle. Reading register C clears this bit.

AF - Alarm Event Flag

7	6	5	4	3	2	1	0
-	-	AF	-	-	-	-	-

This bit is set to a 1 when an alarm event occurs. Reading register C clears this bit.

PF - Periodic Event Flag

7	6	5	4	3	2	1	0
-	PF	-	-	-	-	-	-

This bit is set to a 1 every t_{PI} time, where t_{PI} is the time period selected by the settings of RS0–RS3 in register A. Reading register C clears this bit.

INTF - Interrupt Request Flag

7	6	5	4	3	2	1	0
INTF	-	-	-	-	-	-	-

This flag is set to a 1 when any of the following is true:

AIE = 1 and AF = 1

PIE = 1 and PF = 1

UIE = 1 and UF = 1

Reading register C clears this bit.

Register D

Register D Bits							
7	6	5	4	3	2	1	0
VRT	0	DA5	DA4	DA3	DA2	DA1	DA0

Register D provides for the read-only data integrity status bit, and the day-of-the-month alarm.

Bits 6 - Unused Bit

7	6	5	4	3	2	1	0
-	0	-	-	-	-	-	-

This bit is always set to 0.

VRT - Valid RAM and Time

7	6	5	4	3	2	1	0
VRT	-	-	-	-	-	-	-

1 = Valid backup energy source

0 = Backup energy source is depleted

When the backup energy source is depleted (VRT = 0), data integrity of the RTC and storage registers is not guaranteed.

DA0–DA5

7	6	5	4	3	2	1	0
-	-	DA5	DA4	DA3	DA2	DA1	DA0

These bits store the value for the day-of-the-month alarm. If DA0–DA5 are set to zero, then the day-of-the-month alarm is disabled. These bits are not affected by a reset.

Standard Bank Index

7	6	5	4	3	2	1	0
NMI	SI6	SI5	SI4	SI3	SI2	SI1	SI0

This register contains a copy of the last index value used for the standard bank of SRAM, and non-maskable interrupt, and is read only.

Extended Bank Index

7	6	5	4	3	2	1	0
CENT	EI6	EI5	EI4	EI3	EI2	EI1	EI0

This register contains a copy of the last index value used for the extended bank of SRAM and century bit. For years 80–90, set CENT = 1. For years 00–79, set CENT = 0.

Absolute Maximum Ratings

Symbol	Parameter	Value	Unit	Conditions
V _{CC}	DC voltage applied on V _{CC} relative to V _{SS}	-0.3 to 7.0	V	
V _T	DC voltage applied on any pin excluding V _{CC} relative to V _{SS}	-0.3 to 7.0	V	V _T ≤ V _{CC} + 0.3
T _{OPR}	Operating temperature	0 to +70	°C	Commercial
T _{STG}	Storage temperature	-55 to +125	°C	
T _{BIAS}	Temperature under bias	-40 to +85	°C	
T _{SOLDER}	Soldering temperature	260	°C	For 10 seconds

Note: Permanent device damage may occur if **Absolute Maximum Ratings** are exceeded. Functional operation should be limited to the Recommended DC Operating Conditions detailed in this data sheet. Exposure to conditions beyond the operational limits for extended periods of time may affect device reliability.

Recommended DC Operating Conditions (T_A = T_{OPR}, V_{CC} = 3V unless otherwise noted)

Symbol	Parameter	Minimum	Typical	Maximum	Unit	Notes
V _{CC}	Supply voltage	2.7	3.0	5.5	V	
V _{SS}	Supply voltage	0	0	0	V	
V _{IL}	Input low voltage	-0.3	-	0.6	V	
V _{IH}	Input high voltage	2.2	-	V _{CC} + 0.3	V	
		2.8	-	V _{CC} + 0.3	V	V _{CC} = 5V
V _{BC}	Backup cell voltage	2.4	-	4.0	V	

Note: Typical values indicate operation at T_A = 25°C.

Crystal Specifications (DT-26 or Equivalent)

Symbol	Parameter	Minimum	Typical	Maximum	Unit
f ₀	Oscillation frequency	-	32.768	-	kHz
C _L	Load capacitance	-	6	-	pF
T _P	Temperature turnover point	20	25	30	°C
k	Parabolic curvature constant	-	-	-0.042	ppm/°C
Q	Quality factor	40,000	70,000	-	
R ₁	Series resistance	-	-	45	KΩ
C ₀	Shunt capacitance	-	1.1	1.8	pF
C ₀ /C ₁	Capacitance ratio	-	430	600	
D _L	Drive level	-	-	1	μW
Δf/f ₀	Aging (first year at 25°C)	-	1	-	ppm

bq3285LF

DC Electrical Characteristics ($T_A = T_{OPR}$, $V_{CC} = 3V$)

Symbol	Parameter	Minimum	Typical ¹	Maximum	Unit	Conditions/Notes
I _{LI}	Input leakage current	-	-	± 1	μA	V _{IN} = V _{SS} to V _{CC}
I _{LO}	Output leakage current	-	-	± 1	μA	AD ₀ –AD ₇ and \overline{INT} in high impedance, V _{OUT} = V _{SS} to V _{CC}
V _{OH}	Output high voltage	2.2	-	-	V	I _{OH} = -1.0 mA
V _{OL}	Output low voltage	-	-	0.4	V	I _{OL} = 2.0 mA
I _{CC}	Operating supply current	-	5 ²	9	mA	Min. cycle, duty = 100%, I _{OH} = 0mA, I _{OL} = 0mA
I _{CCSB}	Standby supply current	-	100 ³	-	μA	V _{IN} = V _{SS} or V _{CC} , CS ≥ V _{CC} - 0.2
V _{SO}	Supply switch-over voltage	-	V _{PFD}	-	V	V _{BC} > V _{PFD}
		-	V _{BC}	-	V	V _{BC} < V _{PFD}
I _{CCB}	Battery operation current	-	0.4	0.55	μA	V _{BC} = 3V, T _A = 25°C, V _{CC} < V _{BC}
V _{PFD}	Power-fail-detect voltage	2.4	2.53	2.65	V	
I _{RCL}	Input current when $\overline{RCL} = V_{SS}$.	-	-	120	μA	Internal 30K pull-up
I _{MOTH}	Input current when MOT = V _{CC}	-	-	-120	μA	Internal 30K pull-down
	Input current when MOT = V _{SS}	-	-	0	μA	Internal 30K pull-down
I _{EXTRAM}	Input current when EXTRAM = V _{CC}	-	-	-120	μA	Internal 30K pull-down
	Input current when EXTRAM = V _{SS}	-	-	0	μA	Internal 30K pull-down

- Notes:**
1. Typical values indicate operation at T_A = 25°C, V_{CC} = 3V.
 2. 7mA at V_{CC} = 5V
 3. 300μA at V_{CC} = 5V

Capacitance ($T_A = 25^\circ\text{C}$, $F = 1\text{MHz}$, $V_{CC} = 5.0\text{V}$)

Symbol	Parameter	Minimum	Typical	Maximum	Unit	Conditions
C_{LO}	Input/output capacitance	-	-	7	pF	$V_{OUT} = 0\text{V}$
C_{IN}	Input capacitance	-	-	5	pF	$V_{IN} = 0\text{V}$

Note: This parameter is sampled and not 100% tested. It does not include the X1 or X2 pin.

AC Test Conditions

Parameter	Test Conditions
Input pulse levels	0 to 2.3 V, $V_{CC} = 3\text{V}$
Input rise and fall times	5 ns
Input and output timing reference levels	1.2 V (unless otherwise specified)
Output load (including scope and jig)	See Figures 6 and 7

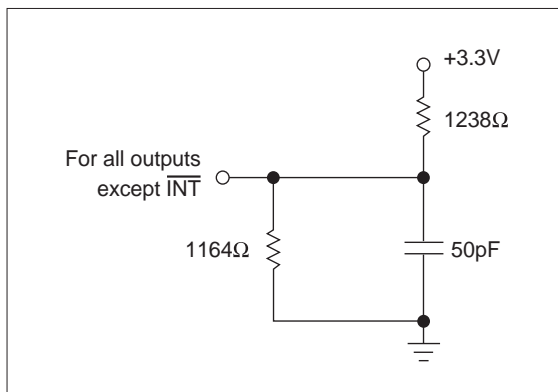

Figure 6. Output Load

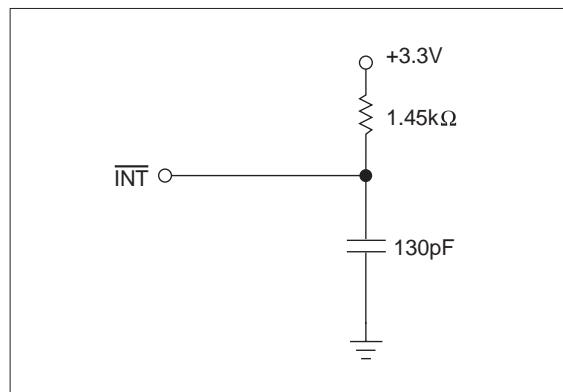

Figure 7. Output Load B

bq3285LF

Read/Write Timing ($T_A = T_{OPR}$, $V_{CC} = 3V$)

Symbol	Parameter	Minimum	Typical	Maximum	Unit	Notes
t _{CYC}	Cycle time	285	-	-	ns	
t _{DSL}	DS low or $\overline{RD}/\overline{WR}$ high time	135	-	-	ns	
t _{DSH}	DS high or $\overline{RD}/\overline{WR}$ low time	90	-	-	ns	
t _{RWH}	R/\overline{W} hold time	0	-	-	ns	
t _{RWS}	R/\overline{W} setup time	15	-	-	ns	
t _{CS}	Chip select setup time	8	-	-	ns	
t _{CH}	Chip select hold time	0	-	-	ns	
t _{DHR}	Read data hold time	0	-	40	ns	
t _{DHW}	Write data hold time	0	-	-	ns	
t _{AS}	Address setup time	30	-	-	ns	
t _{AH}	Address hold time	15	-	-	ns	
t _{DAS}	Delay time, DS to AS rise	30	-	-	ns	
t _{ASW}	Pulse width, AS high	50	-	-	ns	
t _{ASD}	Delay time, AS to DS rise ($\overline{RD}/\overline{WR}$ fall)	55	-	-	ns	
t _{OD}	Output data delay time from DS rise (RD fall)	-	-	100	ns	
t _{DW}	Write data setup time	50	-	-	ns	
t _{BUC}	Delay time before update cycle	-	244	-	μs	
t _{PI}	Periodic interrupt time interval	-	-	-	-	See Table 3
t _{UC}	Time of update cycle	-	1	-	μs	
t _{EXT}	EXTRAM input setup and hold time	15	-	-	ns	

Motorola Bus Read/Write Timing

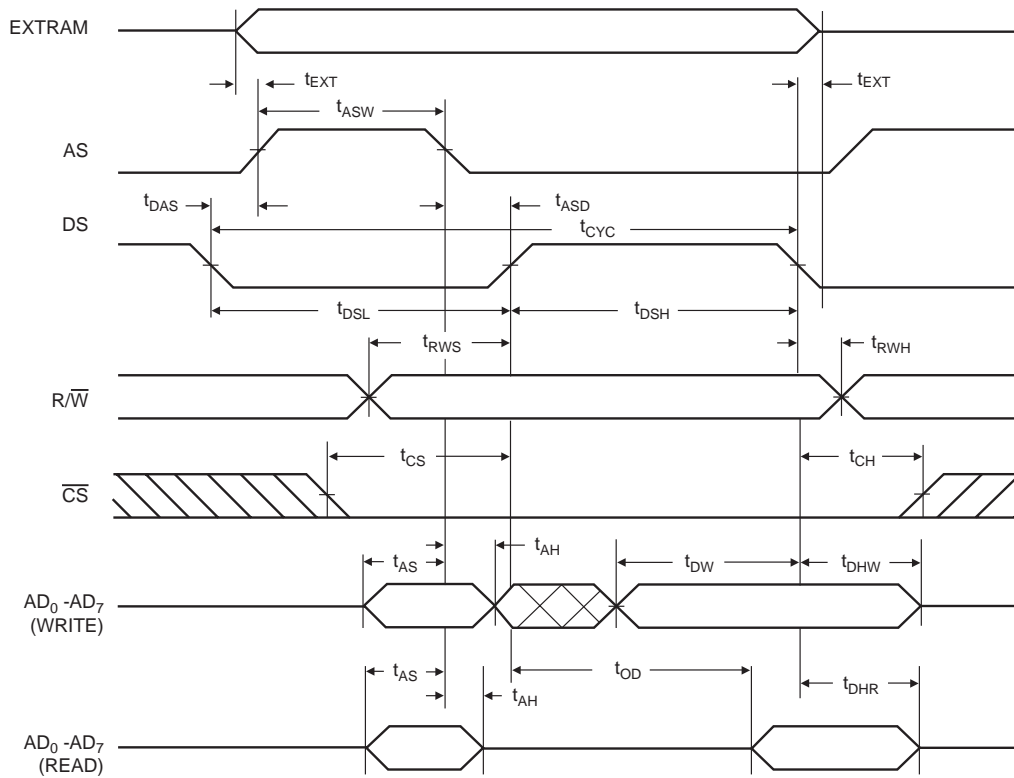

T3285LF3.eps

bq3285LF

Intel Bus Read Timing

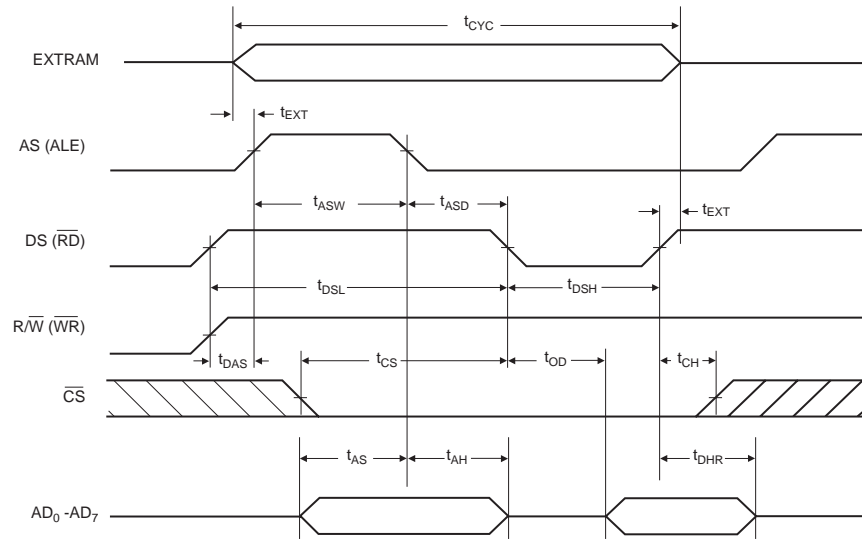

T3285LF4.eps

Intel Bus Write Timing

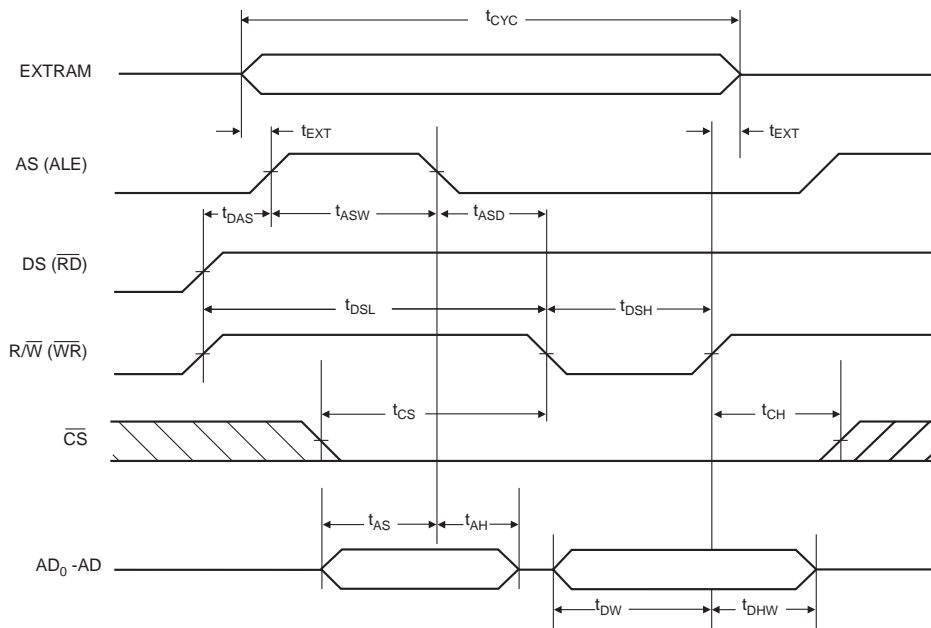

T3285LF5.eps

Power-Down/Power-Up Timing ($T_A = T_{OPR}$)

Symbol	Parameter	Minimum	Typical	Maximum	Unit	Conditions
t_F	V_{CC} slew from 2.7V to 0V	300	-	-	μs	
t_R	V_{CC} slew from 0V to 2.7V	100	-	-	μs	
t_{CSR}	\overline{CS} at V_{IH} after power-up	20	-	200	ms	Internal write-protection period after V_{CC} passes V_{PFD} on power-up.

Caution: Negative undershoots below the absolute maximum rating of -0.3V in battery-backup mode may affect data integrity.

Power-Down/Power-Up Timing

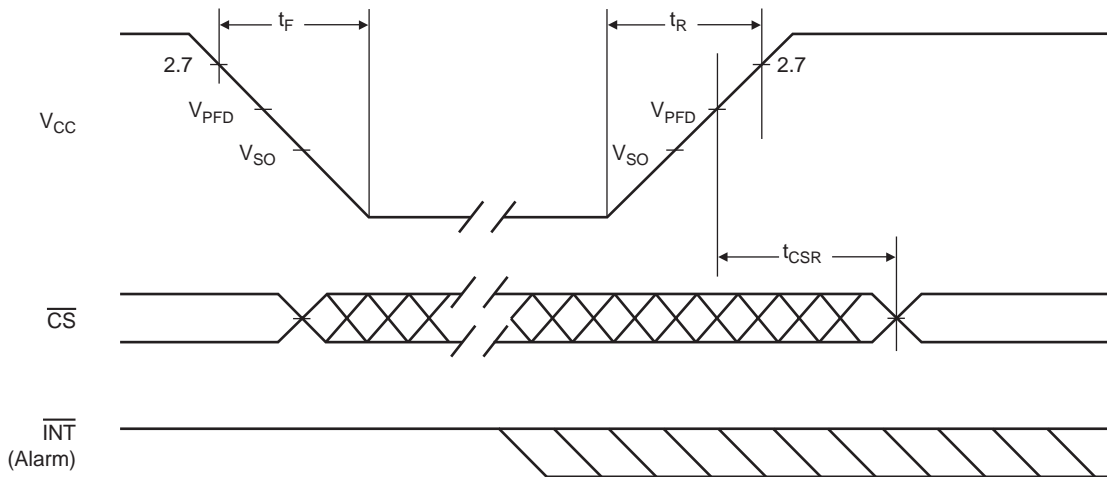

T3285L06.eps

bq3285LF

Interrupt Delay Timing ($T_A = T_{OPR}$)

Symbol	Parameter	Minimum	Typical	Maximum	Unit
t_{RSW}	Reset pulse width	5	-	-	μs
t_{IRR}	\overline{INT} release from \overline{RST}	-	-	2	μs
t_{IRD}	\overline{INT} release from DS	-	-	2	μs

Interrupt Delay Timing

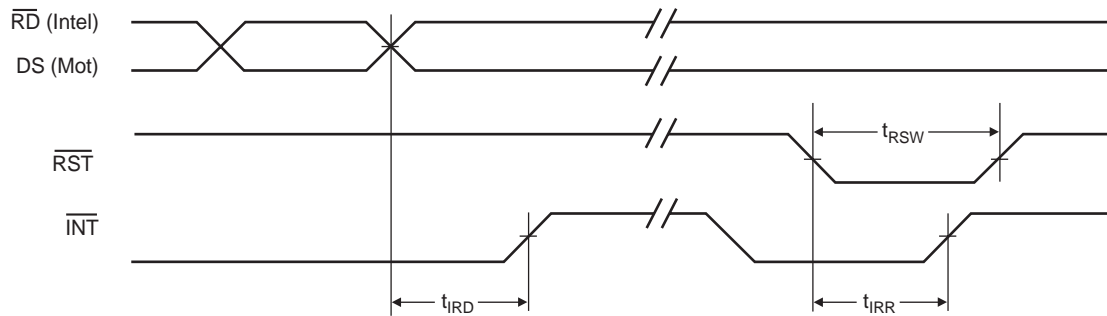

T3285L07.eps

24-Pin SSOP (SS)

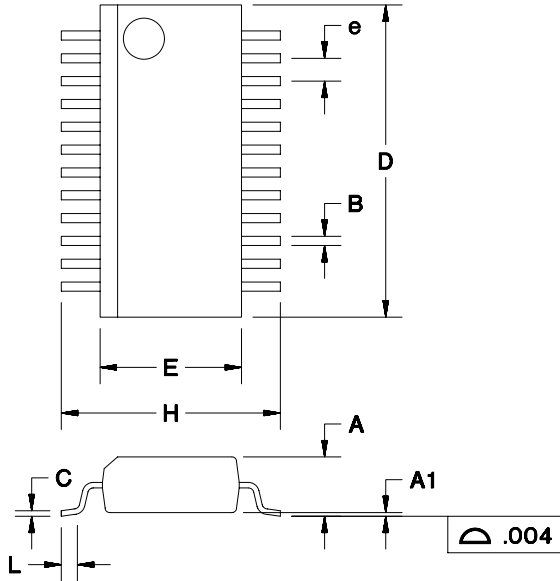

24-Pin SS (0.150" SSOP)

Dimension	Inches		Millimeters	
	Min.	Max.	Min.	Max.
A	0.061	0.068	1.55	1.73
A1	0.004	0.010	0.10	0.25
B	0.008	0.012	0.20	0.30
C	0.007	0.010	0.18	0.25
D	0.337	0.344	8.56	8.74
E	0.150	0.157	3.81	3.99
e	.025 BSC		0.64 BSC	
H	0.230	0.244	5.84	6.20
L	0.016	0.035	0.41	0.89

Data Sheet Revision History

ChangeNo.	Page No.	Description of Change
1	All	"Final" changes from "Preliminary"

Notes: Change 1 = June 1999 B "Final" changes from April 1999 "Preliminary."

Ordering Information

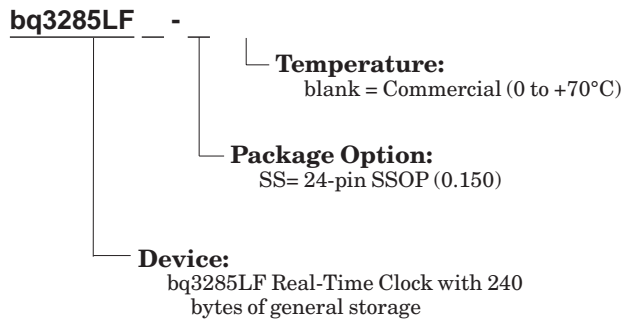

IMPORTANT NOTICE

Texas Instruments and its subsidiaries (TI) reserve the right to make changes to their products or to discontinue any product or service without notice, and advise customers to obtain the latest version of relevant information to verify, before placing orders, that information being relied on is current and complete. All products are sold subject to the terms and conditions of sale supplied at the time of order acknowledgement, including those pertaining to warranty, patent infringement, and limitation of liability.

TI warrants performance of its semiconductor products to the specifications applicable at the time of sale in accordance with TI's standard warranty. Testing and other quality control techniques are utilized to the extent TI deems necessary to support this warranty. Specific testing of all parameters of each device is not necessarily performed, except those mandated by government requirements.

CERTAIN APPLICATIONS USING SEMICONDUCTOR PRODUCTS MAY INVOLVE POTENTIAL RISKS OF DEATH, PERSONAL INJURY, OR SEVERE PROPERTY OR ENVIRONMENTAL DAMAGE ("CRITICAL APPLICATIONS"). TI SEMICONDUCTOR PRODUCTS ARE NOT DESIGNED, AUTHORIZED, OR WARRANTED TO BE SUITABLE FOR USE IN LIFE-SUPPORT DEVICES OR SYSTEMS OR OTHER CRITICAL APPLICATIONS. INCLUSION OF TI PRODUCTS IN SUCH APPLICATIONS IS UNDERSTOOD TO BE FULLY AT THE CUSTOMER'S RISK.

In order to minimize risks associated with the customer's applications, adequate design and operating safeguards must be provided by the customer to minimize inherent or procedural hazards.

TI assumes no liability for applications assistance or customer product design. TI does not warrant or represent that any license, either express or implied, is granted under any patent right, copyright, mask work right, or other intellectual property right of TI covering or relating to any combination, machine, or process in which such semiconductor products or services might be or are used. TI's publication of information regarding any third party's products or services does not constitute TI's approval, warranty or endorsement thereof.

PACKAGING INFORMATION

Orderable Device	Status ⁽¹⁾	Package Type	Package Drawing	Pins	Package Qty	Eco Plan ⁽²⁾	Lead/Ball Finish	MSL Peak Temp ⁽³⁾
BQ3285LFSS-A1	ACTIVE	SSOP/ QSOP	DBQ	24	50	Pb-Free (RoHS)	CU NIPDAU	Level-2-260C-1YEAR/ Level-1-220C-UNLIM
BQ3285LFSS-A1TR	ACTIVE	SSOP/ QSOP	DBQ	24	2500	Pb-Free (RoHS)	CU NIPDAU	Level-2-260C-1YEAR/ Level-1-220C-UNLIM

⁽¹⁾ The marketing status values are defined as follows:

ACTIVE: Product device recommended for new designs.

LIFEBUY: TI has announced that the device will be discontinued, and a lifetime-buy period is in effect.

NRND: Not recommended for new designs. Device is in production to support existing customers, but TI does not recommend using this part in a new design.

PREVIEW: Device has been announced but is not in production. Samples may or may not be available.

OBsolete: TI has discontinued the production of the device.

⁽²⁾ Eco Plan - May not be currently available - please check <http://www.ti.com/productcontent> for the latest availability information and additional product content details.

None: Not yet available Lead (Pb-Free).

Pb-Free (RoHS): TI's terms "Lead-Free" or "Pb-Free" mean semiconductor products that are compatible with the current RoHS requirements for all 6 substances, including the requirement that lead not exceed 0.1% by weight in homogeneous materials. Where designed to be soldered at high temperatures, TI Pb-Free products are suitable for use in specified lead-free processes.

Green (RoHS & no Sb/Br): TI defines "Green" to mean "Pb-Free" and in addition, uses package materials that do not contain halogens, including bromine (Br) or antimony (Sb) above 0.1% of total product weight.

⁽³⁾ MSL, Peak Temp. -- The Moisture Sensitivity Level rating according to the JEDEC industry standard classifications, and peak solder temperature.

Important Information and Disclaimer: The information provided on this page represents TI's knowledge and belief as of the date that it is provided. TI bases its knowledge and belief on information provided by third parties, and makes no representation or warranty as to the accuracy of such information. Efforts are underway to better integrate information from third parties. TI has taken and continues to take reasonable steps to provide representative and accurate information but may not have conducted destructive testing or chemical analysis on incoming materials and chemicals. TI and TI suppliers consider certain information to be proprietary, and thus CAS numbers and other limited information may not be available for release.

In no event shall TI's liability arising out of such information exceed the total purchase price of the TI part(s) at issue in this document sold by TI to Customer on an annual basis.

IMPORTANT NOTICE

Texas Instruments Incorporated and its subsidiaries (TI) reserve the right to make corrections, modifications, enhancements, improvements, and other changes to its products and services at any time and to discontinue any product or service without notice. Customers should obtain the latest relevant information before placing orders and should verify that such information is current and complete. All products are sold subject to TI's terms and conditions of sale supplied at the time of order acknowledgment.

TI warrants performance of its hardware products to the specifications applicable at the time of sale in accordance with TI's standard warranty. Testing and other quality control techniques are used to the extent TI deems necessary to support this warranty. Except where mandated by government requirements, testing of all parameters of each product is not necessarily performed.

TI assumes no liability for applications assistance or customer product design. Customers are responsible for their products and applications using TI components. To minimize the risks associated with customer products and applications, customers should provide adequate design and operating safeguards.

TI does not warrant or represent that any license, either express or implied, is granted under any TI patent right, copyright, mask work right, or other TI intellectual property right relating to any combination, machine, or process in which TI products or services are used. Information published by TI regarding third-party products or services does not constitute a license from TI to use such products or services or a warranty or endorsement thereof. Use of such information may require a license from a third party under the patents or other intellectual property of the third party, or a license from TI under the patents or other intellectual property of TI.

Reproduction of information in TI data books or data sheets is permissible only if reproduction is without alteration and is accompanied by all associated warranties, conditions, limitations, and notices. Reproduction of this information with alteration is an unfair and deceptive business practice. TI is not responsible or liable for such altered documentation.

Resale of TI products or services with statements different from or beyond the parameters stated by TI for that product or service voids all express and any implied warranties for the associated TI product or service and is an unfair and deceptive business practice. TI is not responsible or liable for any such statements.

Following are URLs where you can obtain information on other Texas Instruments products and application solutions:

Products		Applications	
Amplifiers	amplifier.ti.com	Audio	www.ti.com/audio
Data Converters	dataconverter.ti.com	Automotive	www.ti.com/automotive
DSP	dsp.ti.com	Broadband	www.ti.com/broadband
Interface	interface.ti.com	Digital Control	www.ti.com/digitalcontrol
Logic	logic.ti.com	Military	www.ti.com/military
Power Mgmt	power.ti.com	Optical Networking	www.ti.com/opticalnetwork
Microcontrollers	microcontroller.ti.com	Security	www.ti.com/security
		Telephony	www.ti.com/telephony
		Video & Imaging	www.ti.com/video
		Wireless	www.ti.com/wireless

Mailing Address: Texas Instruments
Post Office Box 655303 Dallas, Texas 75265