

Enhanced RTC With NVRAM Control

Features

- ▶ Direct clock/calendar replacement for IBM® AT-compatible computers and other applications
- ▶ 114 bytes of general nonvolatile storage
- ▶ Enhanced features include:
 - System wake-up capability—alarm interrupt output active in battery-backup mode
 - 2.7–3.6V operation (bq4285L); 4.5–5.5V operation (bq4285E)
 - 32kHz output for power management
- ▶ Automatic backup and write-protect control to external SRAM
- ▶ Functionally compatible with the DS1285
- ▶ Less than 0.5 μA load under battery operation
- ▶ Selectable Intel or Motorola bus timing (PLCC), Intel bus timing (DIP and SOIC)
- ▶ 14 bytes for clock/calendar and control

- ▶ BCD or binary format for clock and calendar data
- ▶ Calendar in day of the week, day of the month, months, and years, with automatic leap-year adjustment
- ▶ Time of day in seconds, minutes, and hours
 - 12- or 24-hour format
 - Optional daylight saving adjustment
- ▶ Programmable square wave output
- ▶ Three individually maskable interrupt event flags:
 - Periodic rates from 122 μs to 500ms
 - Time-of-day alarm once per second to once per day
 - End-of-clock update cycle
- ▶ 24-pin plastic DIP or SOIC

General Description

The CMOS bq4285E/L is a low-power microprocessor peripheral providing a time-of-day clock and 100-year calendar with alarm features and battery operation. Other features include three maskable interrupt sources, square wave output, and 114 bytes of general nonvolatile storage.

A 32.768kHz output is available for sustaining power-management activities. Wake-up capability is provided by an alarm interrupt, which is active in battery-backup mode.

The bq4285E/L write-protects the clock, calendar, and storage registers during power failure. A backup battery then maintains data and operates the clock and calendar.

The bq4285E/L is a fully compatible real-time clock for IBM AT-compatible computers and other applications. The only external components are a 32.768kHz crystal and a backup battery.

The bq4285E/L integrates a battery-backup controller to make a

Pin Connections

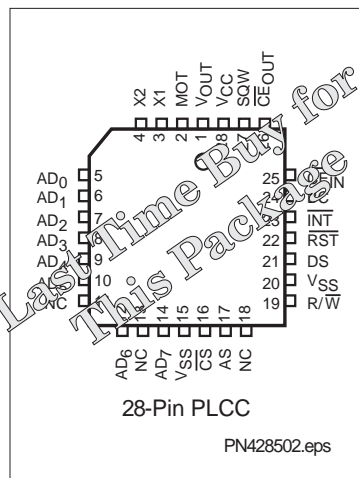
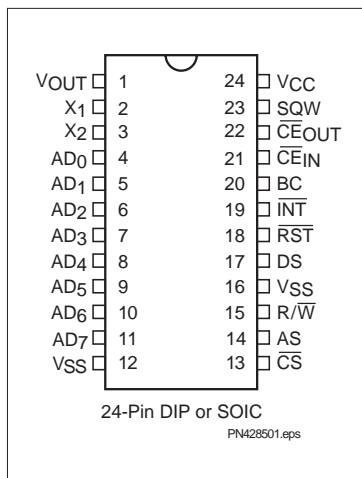

Pin Names

AD ₀ –AD ₇	Multiplexed address/data input/output
MOT	Bus type select input (PLCC only)
CS	Chip select input
AS	Address strobe input
DS	Data strobe input
R/W	Read/write input
INT	Interrupt request output
RST	Reset input
SQW	Square wave output
BC	3V backup cell input
X1–X2	Crystal inputs
NC	No connect
CE _{IN}	RAM chip enable input
CE _{OUT}	RAM chip enable output
V _{OUT}	Supply output
V _{CC}	+5V supply

bq4285E/L

Block Diagram

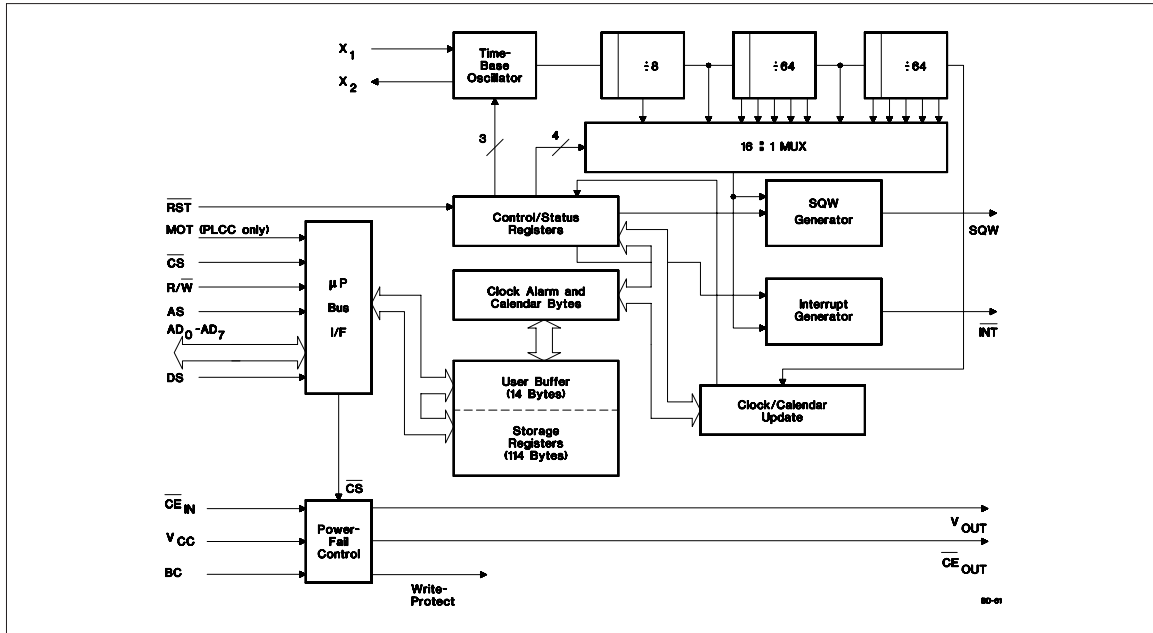

standard CMOS SRAM nonvolatile during power-fail conditions. During power-fail, the bq4285E/L automatically write-protects the external SRAM and provides a V_{CC} output sourced from the clock backup battery.

Pin Descriptions

AD₀-AD₇ Multiplexed address/data input/output

The bq4285E/L bus cycle consists of two phases: the address phase and the data-transfer phase. The address phase precedes the data-transfer phase. During the address phase, an address placed on AD₀-AD₇ is latched into the bq4285E/L on the falling edge of the AS signal. During the data-transfer phase of the bus cycle, the AD₀-AD₇ pins serve as a bidirectional data bus.

MOT Bus type select input (PLCC package only)

MOT selects bus timing for either Motorola or Intel architecture. This pin should be tied to V_{CC} for Motorola timing or to V_{SS} for Intel timing (see Table 1).

The setting should not be changed during system operation. MOT is internally pulled low by a 20KΩ resistor. For the DIP and SOIC packages, this pin is internally connected to V_{SS} , enabling the bus timing for the Intel architecture.

\overline{CS}

Chip select input

\overline{CS} should be driven low and held stable during the data-transfer phase of a bus cycle accessing the bq4285E/L.

Table 1. Bus Setup

Bus Type	MOT Level	DS Equivalent	R \overline{W} Equivalent	AS Equivalent
Motorola	V_{CC}	DS, E, or $\phi 2$	R \overline{W}	AS
Intel	V_{SS}	\overline{RD} , \overline{MEMR} , or I/OR	\overline{WR} , \overline{MEMW} , or I/OW	ALE

AS	<p>Address strobe input</p> <p>AS serves to demultiplex the address/data bus. The falling edge of AS latches the address on AD₀–AD₇. This demultiplexing process is independent of the \overline{CS} signal. For DIP, SOIC, and PLCC packages with MOT = V_{CC}, the AS input is provided a signal similar to ALE in an Intel-based system.</p>		
DS	<p>Data strobe input</p> <p>For DIP, SOIC, and PLCC packages with MOT = V_{SS}, the DS input is provided a signal similar to RD, MEMR, or I/OR in an Intel-based system. The falling edge on DS is used to enable the outputs during a read cycle.</p> <p>For the PLCC package, when MOT = V_{CC}, DS controls data transfer during a bq4285E/L bus cycle. During a read cycle, the bq4285E/L drives the bus after the rising edge on DS. During a write cycle, the falling edge on DS is used to latch write data into the chip.</p>	SQW	<p>Square-wave output</p> <p>SQW may output a programmable frequency square-wave signal during normal (V_{CC} valid) system operation. Any one of the 13 specific frequencies may be selected through register A. This pin is held low when the square-wave enable bit (SQWE) in register B is 0 (see the Control/Status Registers section).</p> <p>A 32.768kHz output is enabled by setting the SQWE bit in register B to 1 and the 32KE bit in register C to 1 after setting OSC2–OSC0 in register A to 011 (binary).</p>
R/W	<p>Read/write input</p> <p>For DIP, SOIC, and PLCC packages with MOT = V_{SS}, R/W is provided a signal similar to WR, MEMW, or I/OW in an Intel-based system. The rising edge on R/W latches data into the bq4285E/L.</p> <p>For the PLCC package, when MOT = V_{CC}, the level on R/W identifies the direction of data transfer. A high level on R/W indicates a read bus cycle, whereas a low on this pin indicates a write bus cycle.</p>	BC	<p>3V backup cell input</p> <p>BC should be connected to a 3V backup cell for RTC operation and storage register non-volatility in the absence of power. When V_{CC} slews down past V_{BC} (3V typical), the integral control circuitry switches the power source to BC. When V_{CC} returns above V_{BC}, the power source is switched to V_{CC}.</p> <p>Upon power-up, a voltage within the V_{BC} range must be present on the BC pin for the oscillator to start up.</p>
INT	<p>Interrupt request output</p> <p>\overline{INT} is an open-drain output. This allows \overline{INT} to be valid in battery-backup mode for the alarm interrupt. To use this feature, \overline{INT} must be connected to a power supply other than V_{CC}. \overline{INT} is asserted low when any event flag is set and the corresponding event enable bit is also set. \overline{INT} becomes high-impedance whenever register C is read (see the Control/Status Registers section).</p>	X1–X2	<p>Crystal inputs</p> <p>The X1–X2 inputs are provided for an external 32.768Khz quartz crystal, Daiwa DT-26 or equivalent, with 6pF load capacitance. A trimming capacitor may be necessary for extremely precise time-base generation.</p>
RST	<p>Reset input</p> <p>The bq4285E/L is reset when \overline{RST} is pulled low. When reset, \overline{INT} becomes high-impedance, and the bq4285E/L is not accessible. Table 4 in the Control/Status Registers section lists the register bits that are cleared by a reset.</p>	\overline{CE}_{IN}	<p>External RAM chip enable input, active low</p> <p>\overline{CE}_{IN} should be driven low to enable the controlled external RAM. \overline{CE}_{IN} is internally pulled up with a 50KΩ resistor.</p>
		\overline{CE}_{OUT}	<p>External RAM chip enable output, active low</p> <p>When power is valid, \overline{CE}_{OUT} reflects \overline{CE}_{IN}.</p>
		V_{OUT}	<p>Supply output</p> <p>V_{OUT} provides the higher of V_{CC} or V_{BC}, switched internally, to supply external RAM.</p>
		V_{CC}	<p>Positive power supply</p>
		V_{SS}	<p>Ground</p>

bq4285E/L

Functional Description

Address Map

The bq4285E/L provides 14 bytes of clock and control/status registers and 114 bytes of general nonvolatile storage. Figure 1 illustrates the address map for the bq4285L.

Update Period

The update period for the bq4285E/L is one second. The bq4285E/L updates the contents of the clock and calendar locations during the update cycle at the end of each

update period (see Figure 2). The alarm flag bit may also be set during the update cycle.

The bq4285E/L copies the local register updates into the user buffer accessed by the host processor. When a 1 is written to the update transfer inhibit bit (UTI) in register B, the user copy of the clock and calendar bytes remains unchanged, while the local copy of the same bytes continues to be updated every second.

The update-in-progress bit (UIP) in register A is set t_{BUC} time before the beginning of an update cycle (see Figure 2). This bit is cleared and the update-complete flag (UF) is set at the end of the update cycle.

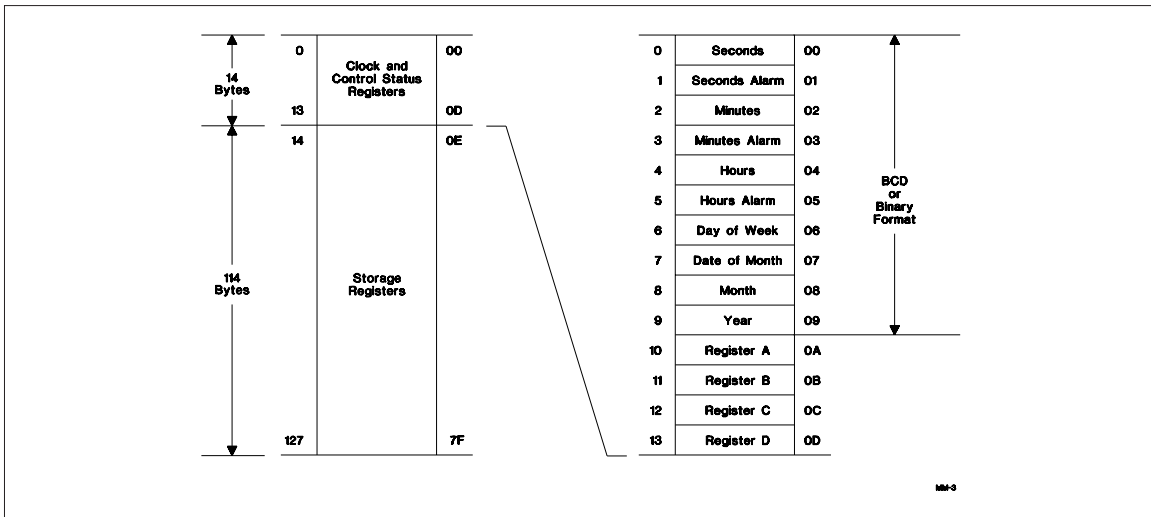

Figure 1. Address Map

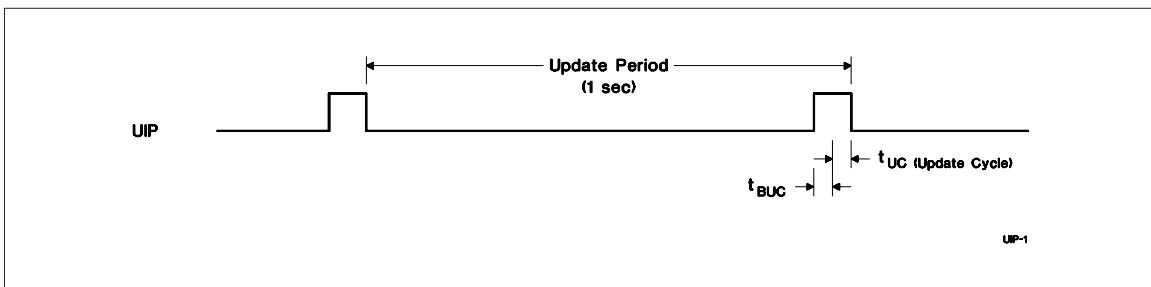

Figure 2. Update Period Timing and UIP

Programming the RTC

The time-of-day, alarm, and calendar bytes can be written in either the BCD or binary format (see Table 2).

These steps may be followed to program the time, alarm, and calendar:

1. Modify the contents of register B:
 - a. Write a 1 to the UTI bit to prevent transfers between RTC bytes and user buffer.
 - b. Write the appropriate value to the data format (DF) bit to select BCD or binary format for all time, alarm, and calendar bytes.
 - c. Write the appropriate value to the hour format (HF) bit.

2. Write new values to all the time, alarm, and calendar locations.
3. Clear the UTI bit to allow update transfers.

On the next update cycle, the RTC updates all 10 bytes in the selected format.

Square-Wave Output

The bq4285E/L divides the 32.768kHz oscillator frequency to produce the 1 Hz update frequency for the clock and calendar. Thirteen taps from the frequency divider are fed to a 16:1 multiplexer circuit. The output of this mux is fed to the SQW output and periodic interrupt generation circuitry. The four least-significant bits of register A, RS0–RS3, select among the 13 taps (see Table 3). The square-wave output is enabled by writing a 1 to the square-wave enable bit (SQWE) in register B. A 32.768kHz output may be selected by setting OSC2–OSC0 in register A to 011 while SQWE = 1 and 32KE = 1.

Table 2. Time, Alarm, and Calendar Formats

Address	RTC Bytes	Range		
		Decimal	Binary	Binary-Coded Decimal
0	Seconds	0–59	00H–3BH	00H–59H
1	Seconds alarm	0–59	00H–3BH	00H–59H
2	Minutes	0–59	00H–3BH	00H–59H
3	Minutes alarm	0–59	00H–3BH	00H–59H
4	Hours, 12-hour format	1–12	01H–0CH AM; 81H–8CH PM	01H–12H AM; 81H–92H PM
	Hours, 24-hour format	0–23	00H–17H	00H–23H
5	Hours alarm, 12-hour format	1–12	01H–0CH AM; 81H–8CH PM	01H–12H AM; 81H–92H PM
	Hours alarm, 24-hour format	0–23	00H–17H	00H–23H
6	Day of week (1=Sunday)	1–7	01H–07H	01H–07H
7	Day of month	1–31	01H–1FH	01H–31H
8	Month	1–12	01H–0CH	01H–12H
9	Year	0–99	00H–63H	00H–99H

bq4285E/L

Interrupts

The bq4285E/L allows three individually selected interrupt events to generate an interrupt request. These three interrupt events are:

- The periodic interrupt, programmable to occur once every 122µs to 500 ms.
- The alarm interrupt, programmable to occur once per second to once per day, is active in battery-backup mode, providing a “wake-up” feature.
- The update-ended interrupt, which occurs at the end of each update cycle.

Each of the three interrupt events is enabled by an individual interrupt-enable bit in register B. When an event occurs, its event flag bit in register C is set. If the corresponding event enable bit is also set, then an interrupt request is generated. The interrupt request flag bit (INTF) of register C is set with every interrupt request. Reading register C clears all flag bits, including INTF, and makes INT high-impedance.

Two methods can be used to process bq4285E/L interrupt events:

- Enable interrupt events and use the interrupt request output to invoke an interrupt service routine.
- Do not enable the interrupts and use a polling routine to periodically check the status of the flag bits.

The individual interrupt sources are described in detail in the following sections.

Periodic Interrupt

The mux output used to drive the SQW output also drives the interrupt-generation circuitry. If the periodic interrupt event is enabled by writing a 1 to the periodic interrupt enable bit (PIE) in register C, an interrupt request is generated once every 122µs to 500ms. The period between interrupts is selected by the same bits in register A that select the square wave frequency (see Table 3). Setting OSC2–OSC0 in register A to 011 does not affect the periodic interrupt timing.

Table 3. Square-Wave Frequency/Periodic Interrupt Rate

Register A Bits							Square Wave		Periodic Interrupt	
OSC2	OSC1	OSC0	RS3	RS2	RS1	RS0	Frequency	Units	Period	Units
0	1	0	0	0	0	0	None		None	
0	1	0	0	0	0	1	256	Hz	3.90625	ms
0	1	0	0	0	1	0	128	Hz	7.8125	ms
0	1	0	0	0	1	1	8.192	kHz	122.070	µs
0	1	0	0	1	0	0	4.096	kHz	244.141	µs
0	1	0	0	1	0	1	2.048	kHz	488.281	µs
0	1	0	0	1	1	0	1.024	kHz	976.5625	µs
0	1	0	0	1	1	1	512	Hz	1.95315	ms
0	1	0	1	0	0	0	256	Hz	3.90625	ms
0	1	0	1	0	0	1	128	Hz	7.8125	ms
0	1	0	1	0	1	0	64	Hz	15.625	ms
0	1	0	1	0	1	1	32	Hz	31.25	ms
0	1	0	1	1	0	0	16	Hz	62.5	ms
0	1	0	1	1	0	1	8	Hz	125	ms
0	1	0	1	1	1	0	4	Hz	250	ms
0	1	0	1	1	1	1	2	Hz	500	ms
0	1	1	X	X	X	X	32.768	kHz	same as above defined by RS3–RS0	

Alarm Interrupt

The alarm interrupt request is valid in battery-backup mode, providing a “wake-up” capability. During each update cycle, the RTC compares the hours, minutes, and seconds bytes with the three corresponding alarm bytes. If a match of all bytes is found, the alarm interrupt event flag bit, AF in register C, is set to 1. If the alarm event is enabled, an interrupt request is generated.

An alarm byte may be removed from the comparison by setting it to a “don’t care” state. An alarm byte is set to a “don’t care” state by writing a 1 to each of its two most-significant bits. A “don’t care” state may be used to select the frequency of alarm interrupt events as follows:

- If none of the three alarm bytes is “don’t care,” the frequency is once per day, when hours, minutes, and seconds match.
- If only the hour alarm byte is “don’t care,” the frequency is once per hour, when minutes and seconds match.
- If only the hour and minute alarm bytes are “don’t care,” the frequency is once per minute, when seconds match.
- If the hour, minute, and second alarm bytes are “don’t care,” the frequency is once per second.

Update Cycle Interrupt

The update cycle ended flag bit (UF) in register C is set to a 1 at the end of an update cycle. If the update interrupt enable bit (UIE) of register B is 1, and the update transfer inhibit bit (UTI) in register B is 0, then an interrupt request is generated at the end of each update cycle.

Accessing RTC bytes

Time and calendar bytes read during an update cycle may be in error. Three methods to access the time and calendar bytes without ambiguity are:

- Enable the update interrupt event to generate interrupt requests at the end of the update cycle. The interrupt handler has a maximum of 999ms to access the clock bytes before the next update cycle begins (see Figure 3).
- Poll the update-in-progress bit (UIP) in register A. If $UIP = 0$, the polling routine has a minimum of t_{BUC} time to access the clock bytes (see Figure 3).
- Use the periodic interrupt event to generate interrupt requests every t_{PI} time, such that $UIP = 1$ always occurs between the periodic interrupts. The interrupt handler will have a minimum of $t_{PI}/2 + t_{BUC}$ time to access the clock bytes (see Figure 3).

Oscillator Control

When power is first applied to the bq4285E/L and V_{CC} is above V_{PPD} , the internal oscillator and frequency divider are turned on by writing a 010 pattern to bits 4 through 6 of register A. A pattern of 011 behaves as 010 but additionally transforms register C into a read/write register. This allows the 32.768kHz output on the square wave pin to be turned on. A pattern of 11X turns the oscillator on, but keeps the frequency divider disabled. Any other pattern to these bits keeps the oscillator off.

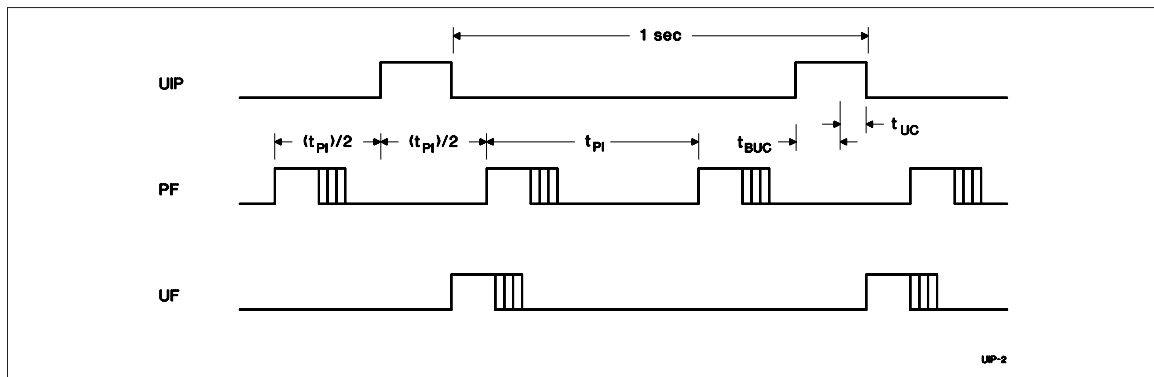

Figure 3. Update-Ended/Periodic Interrupt Relationship

bq4285E/L

Power-Down/Power-Up Cycle

The bq4285E/L power-up/power-down cycles are different. The bq4285L continuously monitors V_{CC} for out-of-tolerance. During a power failure, when V_{CC} falls below V_{PFD} (2.53V typical), the bq4285L write-protects the clock and storage registers. The power source is switched to BC when V_{CC} is less than V_{PFD} and BC is greater than V_{PFD} , or when V_{CC} is less than V_{BC} and V_{BC} is less than V_{PFD} . RTC operation and storage data are sustained by a valid backup energy source. When V_{CC} is above V_{PFD} , the power source is V_{CC} . Write-protection continues for t_{CSR} time after V_{CC} rises above V_{PFD} .

The bq4285E continuously monitors V_{CC} for out-of-tolerance. During a power failure, when V_{CC} falls below V_{PFD} (4.17V typical), the bq4285E write-protects the clock and storage registers. When V_{CC} is below V_{BC} (3V typical), the power source is switched to BC. RTC operation and storage data are sustained by a valid backup energy source. When V_{CC} is above V_{BC} , the power source is V_{CC} . Write-protection continues for t_{CSR} time after V_{CC} rises above V_{PFD} .

An external CMOS static RAM is battery-backed using the V_{OUT} and chip enable output pins from the bq4285E/L. As the voltage input V_{CC} slows down during a power failure, the chip enable output, \overline{CE}_{OUT} is forced inactive independent of the chip enable input \overline{CE}_{IN} .

This activity unconditionally write-protects the external SRAM as V_{CC} falls below V_{PFD} . If a memory access is in process to the external SRAM during power-fail detection, that memory cycle continues to completion before the memory is write-protected. If the memory cycle is

not terminated within time t_{WPT} (30 μ s maximum), the chip enable output is unconditionally driven high, write-protecting the controlled SRAM.

As the supply continues to fall past V_{PFD} , an internal switching device forces V_{OUT} to the external backup energy source. \overline{CE}_{OUT} is held high by the V_{OUT} energy source.

During power-up, V_{OUT} is switched back to the main supply as V_{CC} rises above the backup cell input voltage sourcing V_{OUT} . If $V_{PFD} < V_{BC}$ on the bq4285L, the switch to the main supply occurs at V_{PFD} . \overline{CE}_{OUT} is held inactive for time t_{CER} (200ms maximum) after the power supply has reached V_{PFD} , independent of the \overline{CE}_{IN} input, to allow for processor stabilization.

During power-valid operation, the \overline{CE}_{IN} input is passed through to the \overline{CE}_{OUT} output with a propagation delay of less than 10ns.

Figure 4 shows the hardware hookup for the external RAM.

A primary backup energy source input is provided on the bq4285E/L. The BC input accepts a 3V primary battery, typically some type of lithium chemistry. To prevent battery drain when there is no valid data to retain, V_{OUT} and \overline{CE}_{OUT} are internally isolated from BC by the initial connection of a battery. Following the first application of V_{CC} above V_{PFD} , this isolation is broken, and the backup cell provides power to V_{OUT} and \overline{CE}_{OUT} for the external SRAM.

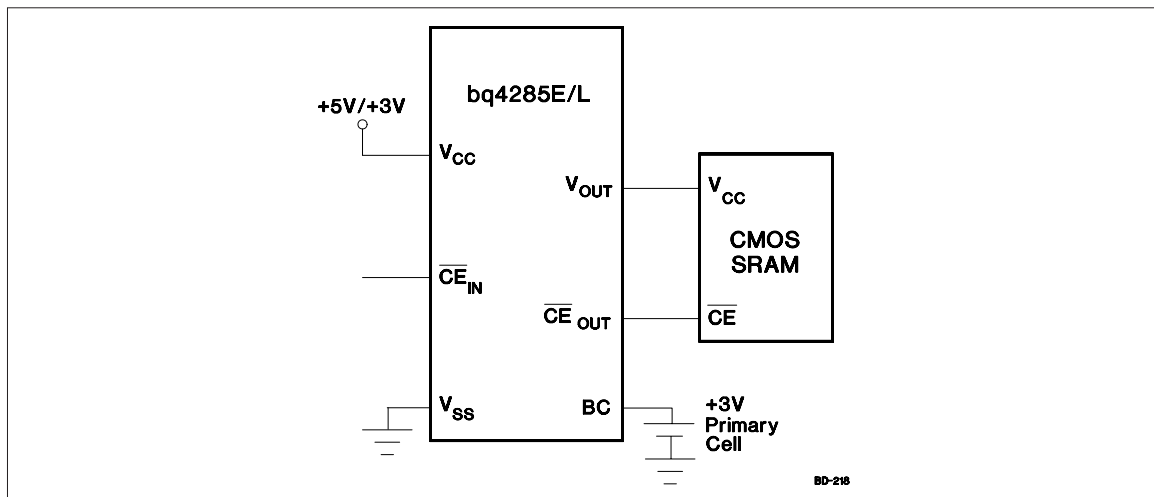

Figure 4. External RAM Hookup to the bq4285E/L RTC

Control/Status Registers

The four control/status registers of the bq4285E/L are accessible regardless of the status of the update cycle (see Table 4).

Register A

Register A Bits							
7	6	5	4	3	2	1	0
UIP	OS2	OS1	OS0	RS3	RS2	RS1	RS0

Register A programs:

- The frequency of the square-wave and the periodic event rate.
- Oscillator operation.

Register A provides:

- Status of the update cycle.

RS0–RS3 - Frequency Select

7	6	5	4	3	2	1	0
-	-	-	-	RS3	RS2	RS1	RS0

These bits select one of the 13 frequencies for the SQW output and the periodic interrupt rate, as shown in Table 3.

OS0–OS2 - Oscillator Control

7	6	5	4	3	2	1	0
-	OS2	OS1	OS0	-	-	-	-

These three bits control the state of the oscillator and divider stages. A pattern of 010 enables RTC operation by turning on the oscillator and enabling the frequency di-

vider. A pattern of 011 behaves as 010 but additionally transforms register C into a read/write register. This allows the 32.768kHz output on the square wave pin to be turned on. A pattern of 11X turns the oscillator on, but keeps the frequency divider disabled. When 010 is written, the RTC begins its first update after 500ms.

UIP - Update Cycle Status

7	6	5	4	3	2	1	0
UIP	-	-	-	-	-	-	-

This read-only bit is set prior to the update cycle. When UIP equals 1, an RTC update cycle may be in progress. UIP is cleared at the end of each update cycle. This bit is also cleared when the update transfer inhibit (UTI) bit in register B is 1.

Register B

Register B Bits							
7	6	5	4	3	2	1	0
UTI	PIE	AIE	UIE	SQWE	DF	HF	DSE

Register B enables:

- Update cycle transfer operation
- Square-wave output
- Interrupt events
- Daylight saving adjustment

Register B selects:

- Clock and calendar data formats

All bits of register B are read/write.

Table 4. Control/Status Registers

Reg.	Loc. (Hex)	Read	Write	Bit Name and State on Reset															
				7 (MSB)	6		5		4		3		2		1		0 (LSB)		
A	0A	Yes	Yes ¹	UIP	na	OS2	na	OS1	na	OS0	na	RS3	na	RS2	na	RS1	na	RS0	na
B	0B	Yes	Yes	UTI	na	PIE	0	AIE	0	UIE	0	SQWE	0	DF	na	HF	na	DSE	na
C	0C	Yes	No ²	INTF	0	PF	0	AF	0	UF	0	-	0	32KE	na	-	0	-	0
D	0D	Yes	No	VRT	na	-	0	-	0	-	0	-	0	-	0	-	0	-	0

Notes: na = not affected.

1. Except bit 7.
2. Read/write only when OSC2–OSC0 in register A is 011 (binary).

bq4285E/L

DSE - Daylight Saving Enable

7	6	5	4	3	2	1	0
-	-	-	-	-	-	-	DSE

This bit enables daylight-saving time adjustments when written to 1:

- On the last Sunday in October, the first time the bq4285E/L increments past 1:59:59 AM, the time falls back to 1:00:00 AM.
- On the first Sunday in April, the time springs forward from 2:00:00 AM to 3:00:00 AM.

7	6	5	4	3	2	1	0
-	-	-	-	-	-	HF	-

HF - Hour Format

This bit selects the time-of-day and alarm hour format:

1 = 24-hour format

0 = 12-hour format

7	6	5	4	3	2	1	0
-	-	-	-	-	DF	-	-

DF - Data Format

This bit selects the numeric format in which the time, alarm, and calendar bytes are represented:

1 = Binary

0 = BCD

7	6	5	4	3	2	1	0
-	-	-	-	SQWE	-	-	-

SQWE - Square-Wave Enable

This bit enables the square-wave output:

1 = Enabled

0 = Disabled and held low

UIE - Update Cycle Interrupt Enable

7	6	5	4	3	2	1	0
-	-	-	UIE	-	-	-	-

This bit enables an interrupt request due to an update ended interrupt event:

1 = Enabled

0 = Disabled

The UIE bit is automatically cleared when the UTI bit equals 1.

AIE - Alarm Interrupt Enable

7	6	5	4	3	2	1	0
-	-	AIE	-	-	-	-	-

This bit enables an interrupt request due to an alarm interrupt event:

1 = Enabled

0 = Disabled

PIE - Periodic Interrupt Enable

7	6	5	4	3	2	1	0
-	PIE	-	-	-	-	-	-

This bit enables an interrupt request due to a periodic interrupt event:

1 = Enabled

0 = Disabled

UTI - Update Transfer Inhibit

7	6	5	4	3	2	1	0
UTI	-	-	-	-	-	-	-

This bit inhibits the transfer of RTC bytes to the user buffer:

1 = Inhibits transfer and clears UIE

0 = Allows transfer

Register C

Register C Bits							
7	6	5	4	3	2	1	0
INTF	PF	AF	UF	0	32KE	0	0

Register C is the read-only event status register.

Bits 0–3 - Unused Bits

7	6	5	4	3	2	1	0
-	-	-	-	0	-	0	0

These bits are always set to 0.

32KE–32KHz Enable Output

7	6	5	4	3	2	1	0
-	-	-	-	-	32KE	-	-

This bit may be set to a 1 only when the OSC2–OSC0 bits in register A are set to 011. Setting OSC2–OSC0 to anything other than 011 clears this bit. If SQWE in register B and 32KE are set, a 32.768KHz waveform is output on the square wave pin.

UF - Update-Event Flag

7	6	5	4	3	2	1	0
-	-	-	UF	-	-	-	-

This bit is set to a 1 at the end of the update cycle. Reading register C clears this bit.

AF - Alarm Event Flag

7	6	5	4	3	2	1	0
-	-	AF	-	-	-	-	-

This bit is set to a 1 when an alarm event occurs. Reading register C clears this bit.

PF - Periodic Event Flag

7	6	5	4	3	2	1	0
-	PF	-	-	-	-	-	-

This bit is set to a 1 every t_{PI} time, where t_{PI} is the time period selected by the settings of RS0–RS3 in register A. Reading register C clears this bit.

INTF - Interrupt Request Flag

7	6	5	4	3	2	1	0
INTF	-	-	-	-	-	-	-

This flag is set to a 1 when any of the following is true:

AIE = 1 and AF = 1

PIE = 1 and PF = 1

UIE = 1 and UF = 1

Reading register C clears this bit.

Register D

Register D Bits							
7	6	5	4	3	2	1	0
VRT	0	0	0	0	0	0	0

Register D is the read-only data integrity status register.

Bits 0–6 - Unused Bits

7	6	5	4	3	2	1	0
-	0	0	0	0	0	0	0

These bits are always set to 0.

VRT - Valid RAM and Time

7	6	5	4	3	2	1	0
VRT	-	-	-	-	-	-	-

1 = Valid backup energy source

0 = Backup energy source is depleted

When the backup energy source is depleted (VRT = 0), data integrity of the RTC and storage registers is not guaranteed.

bq4285E/L

Absolute Maximum Ratings—bq4285E

Symbol	Parameter	Value	Unit	Conditions
V _{CC}	DC voltage applied on V _{CC} relative to V _{SS}	-0.3 to 7.0	V	
V _T	DC voltage applied on any pin excluding V _{CC} relative to V _{SS}	-0.3 to 7.0	V	V _T ≤ V _{CC} + 0.3
T _{OPR}	Operating temperature	0 to +70	°C	Commercial
		-40 to +85	°C	Industrial “N”
T _{STG}	Storage temperature	-55 to +125	°C	
T _{BIAS}	Temperature under bias	-40 to +85	°C	
T _{SOLDER}	Soldering temperature	260	°C	For 10 seconds

Note: Permanent device damage may occur if **Absolute Maximum Ratings** are exceeded. Functional operation should be limited to the Recommended DC Operating Conditions detailed in this data sheet. Exposure to conditions beyond the operational limits for extended periods of time may affect device reliability.

Absolute Maximum Ratings—bq4285L

Symbol	Parameter	Value	Unit	Conditions
V _{CC}	DC voltage applied on V _{CC} relative to V _{SS}	-0.3 to 6.0	V	
V _T	DC voltage applied on any pin excluding V _{CC} relative to V _{SS}	-0.3 to 6.0	V	V _T ≤ V _{CC} + 0.3
T _{OPR}	Operating temperature	0 to +70	°C	Commercial
T _{STG}	Storage temperature	-55 to +125	°C	
T _{BIAS}	Temperature under bias	-40 to +85	°C	
T _{SOLDER}	Soldering temperature	260	°C	For 10 seconds

Note: Permanent device damage may occur if **Absolute Maximum Ratings** are exceeded. Functional operation should be limited to the Recommended DC Operating Conditions detailed in this data sheet. Exposure to conditions beyond the operational limits for extended periods of time may affect device reliability.

Recommended DC Operating Conditions—bq4285E (T_A = T_{OPR})

Symbol	Parameter	Minimum	Typical	Maximum	Unit
V _{CC}	Supply voltage	4.5	5.0	5.5	V
V _{IL}	Input low voltage	-0.3	-	0.8	V
V _{IH}	Input high voltage	2.2	-	V _{CC} + 0.3	V
V _{BC}	Backup cell voltage	2.5	-	4.0	V

Notes: Typical values indicate operation at T_A = 25°C.
Potentials are relative to V_{SS}.

Recommended DC Operating Conditions—bq4285L (T_A = T_{OPR})

Symbol	Parameter	Minimum	Typical	Maximum	Unit
V _{CC}	Supply voltage	2.7	3.15	3.6	V
V _{IL}	Input low voltage	-0.3	-	0.6	V
V _{IH}	Input high voltage	2.2	-	V _{CC} + 0.3	V
V _{BC}	Backup cell voltage	2.4	-	4.0	V

Notes: Typical values indicate operation at T_A = 25°C.
Potentials are relative to V_{SS}.

Crystal Specifications—bq4285E/L (DT-26 or Equivalent)

Symbol	Parameter	Minimum	Typical	Maximum	Unit
f ₀	Oscillation frequency	-	32.768	-	kHz
C _L	Load capacitance	-	6	-	pF
T _P	Temperature turnover point	20	25	30	°C
k	Parabolic curvature constant	-	-	-0.042	ppm/°C
Q	Quality factor	40,000	70,000	-	
R ₁	Series resistance	-	-	45	KΩ
C ₀	Shunt capacitance	-	1.1	1.8	pF
C ₀ /C ₁	Capacitance ratio	-	430	600	
D _L	Drive level	-	-	1	μW
Δf/f ₀	Aging (first year at 25°C)	-	1	-	ppm

bq4285E/L

DC Electrical Characteristics—bq4285E ($T_A = T_{OPR}$, $V_{CC} = 5V \pm 10\%$)

Symbol	Parameter	Minimum	Typical	Maximum	Unit	Conditions/Notes
I_{LI}	Input leakage current	-	-	± 1	μA	$V_{IN} = V_{SS}$ to V_{CC}
I_{LO}	Output leakage current	-	-	± 1	μA	AD_0 – AD_7 , \overline{INT} , and SQW in high impedance, $V_{OUT} = V_{SS}$ to V_{CC}
V_{OH}	Output high voltage	2.4	-	-	V	$I_{OH} = -2.0$ mA
V_{OL}	Output low voltage	-	-	0.4	V	$I_{OL} = 4.0$ mA
I_{CC}	Operating supply current	-	7	15	mA	Min. cycle, duty = 100%, $I_{OH} = 0$ mA, $I_{OL} = 0$ mA
V_{SO}	Supply switch-over voltage	-	V_{BC}	-	V	
I_{CCB}	Battery operation current	-	0.3	0.5	μA	$V_{BC} = 3V$, $T_A = 25^\circ C$, no load on V_{OUT} or CE_{OUT}
I_{CCSB}	Standby supply current	-	300	-	μA	$V_{IN} = V_{CC}$ or V_{SS} , $CS \geq V_{CC} - 0.2$, no load on V_{OUT}
V_{PFD}	Power-fail-detect voltage	4.0	4.17	4.35	V	
V_{OUT1}	V_{OUT} voltage	$V_{CC} - 0.3V$	-	-	V	$I_{OUT} = 100$ mA, $V_{CC} > V_{BC}$
V_{OUT2}	V_{OUT} voltage	$V_{BC} - 0.3V$				$I_{OUT} = 100$ μA , $V_{CC} < V_{BC}$
I_{MOTH}	Input current when $MOT = V_{CC}$	-	-	-275	μA	Internal 20K pull-down
\overline{I}_{CE}	Chip enable input current	-	-	100	μA	Internal 50K pull-up

Note: Typical values indicate operation at $T_A = 25^\circ C$, $V_{CC} = 5V$ or $V_{BC} = 3V$.

DC Electrical Characteristics—bq4285L ($T_A = T_{OPR}$, $V_{CC} = 3.13V \pm 0.45\%$)

Symbol	Parameter	Minimum	Typical	Maximum	Unit	Conditions/Notes
I_{LI}	Input leakage current	-	-	± 1	μA	$V_{IN} = V_{SS}$ to V_{CC}
I_{LO}	Output leakage current	-	-	± 1	μA	AD_0 – AD_7 , \overline{INT} , and SQW in high impedance, $V_{OUT} = V_{SS}$ to V_{CC}
V_{OH}	Output high voltage	2.2	-	-	V	$I_{OH} = -2.0$ mA
V_{OL}	Output low voltage	-	-	0.4	V	$I_{OL} = 4.0$ mA
I_{CC}	Operating supply current	-	5	9	mA	Min. cycle, duty = 100%, $I_{OH} = 0$ mA, $I_{OL} = 0$ mA
V_{SO}	Supply switch-over voltage	-	V_{PFD}	-	V	$V_{BC} > V_{PFD}$
		-	V_{BC}	-	V	$V_{BC} < V_{PFD}$
I_{CCB}	Battery operation current	-	0.3	0.5	μA	$V_{BC} = 3V$, $T_A = 25^\circ C$, no load on V_{OUT} or \overline{CE}_{OUT}
I_{CCSB}	Standby supply current	-	100	-	μA	$V_{IN} = V_{CC}$ or V_{SS} , $CS \geq V_{CC} - 0.2$, no load on V_{OUT}
V_{PFD}	Power-fail-detect voltage	2.4	2.53	2.65	V	
V_{OUT1}	V_{OUT} voltage	$V_{CC} - 0.3V$	-	-	V	$I_{OUT} = 80$ mA, $V_{CC} > V_{BC}$
V_{OUT2}	V_{OUT} voltage	$V_{BC} - 0.3V$				$I_{OUT} = 100$ μA , $V_{CC} < V_{BC}$
I_{MOTH}	Input current when $MOT = V_{CC}$	-	-	-185	μA	Internal 30K pull-down
\overline{I}_{CE}	Chip enable input current	-	-	120	μA	Internal 30K pull-up

Note: Typical values indicate operation at $T_A = 25^\circ C$, $V_{CC} = 3V$.

bq4285E/L

Capacitance—bq4285E/L ($T_A = 25^\circ\text{C}$, $F = 1\text{MHz}$, $V_{CC} = 5.0\text{V}$)

Symbol	Parameter	Minimum	Typical	Maximum	Unit	Conditions
$C_{I/O}$	Input/output capacitance	-	-	7	pF	$V_{OUT} = 0\text{V}$
C_{IN}	Input capacitance	-	-	5	pF	$V_{IN} = 0\text{V}$

Note: This parameter is sampled and not 100% tested. It does not include the X1 or X2 pin.

AC Test Conditions—bq4285E

Parameter	Test Conditions
Input pulse levels	0 to 3.0 V
Input rise and fall times	5 ns
Input and output timing reference levels	1.5 V (unless otherwise specified)
Output load (including scope and jig)	See Figures 5 and 6

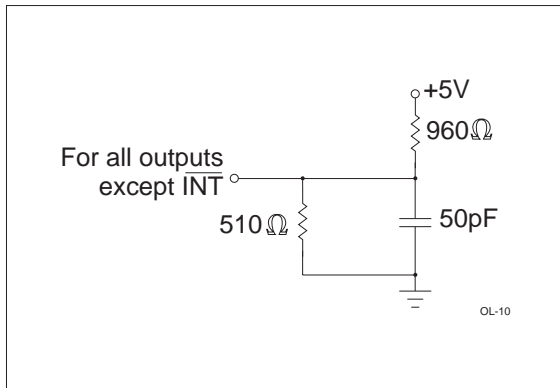

Figure 5. Output Load A—bq4285E

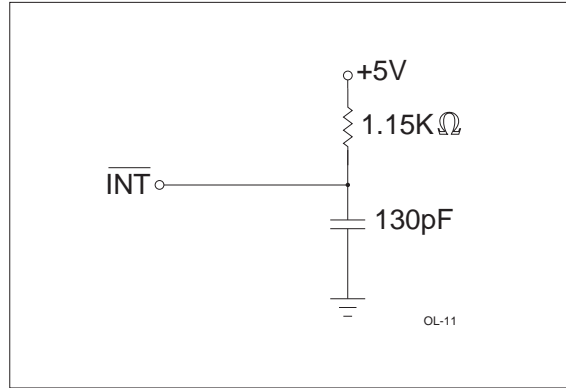

Figure 6. Output Load B—bq4285E

AC Test Conditions—bq4285L

Parameter	Test Conditions
Input pulse levels	0 to 2.3 V
Input rise and fall times	5 ns
Input and output timing reference levels	1.2 V (unless otherwise specified)
Output load (including scope and jig)	See Figures 7 and 8

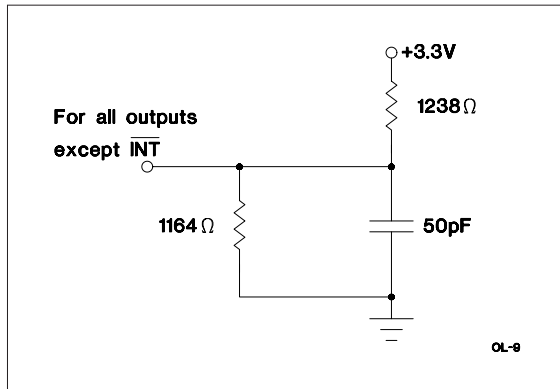

Figure 7. Output Load A—bq4285L

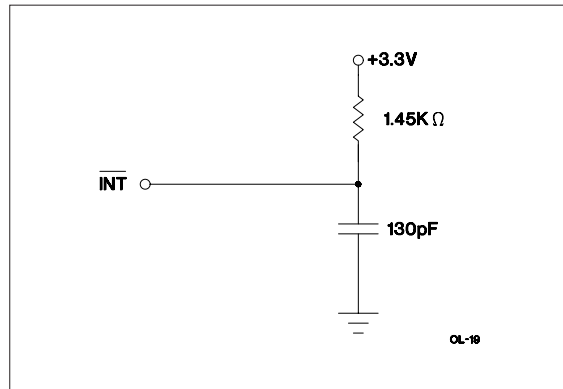

Figure 8. Output Load B—bq4285L

bq4285E/L

Read/Write Timing—bq4285E ($T_A = T_{OPR}$, $V_{CC} = 5V \pm 10\%$)

Symbol	Parameter	Minimum	Typical	Maximum	Unit	Notes
t _{CYC}	Cycle time	160	-	-	ns	
t _{DSL}	DS low or $\overline{RD}/\overline{WR}$ high time	80	-	-	ns	
t _{DSH}	DS high or $\overline{RD}/\overline{WR}$ low time	55	-	-	ns	
t _{RWH}	R/\overline{W} hold time	0	-	-	ns	
t _{RWS}	R/\overline{W} setup time	10	-	-	ns	
t _{CS}	Chip select setup time	5	-	-	ns	
t _{CH}	Chip select hold time	0	-	-	ns	
t _{DHR}	Read data hold time	0	-	25	ns	
t _{DHW}	Write data hold time	0	-	-	ns	
t _{AS}	Address setup time	20	-	-	ns	
t _{AH}	Address hold time	5	-	-	ns	
t _{DAS}	Delay time, DS to AS rise	10	-	-	ns	
t _{ASW}	Pulse width, AS high	30	-	-	ns	
t _{ASD}	Delay time, AS to DS rise ($\overline{RD}/\overline{WR}$ fall)	35	-	-	ns	
t _{OD}	Output data delay time from DS rise (\overline{RD} fall)	-	-	50	ns	
t _{DW}	Write data setup time	30	-	-	ns	
t _{BUC}	Delay time before update	-	244	-	μ s	
t _{PI}	Periodic interrupt time interval	-	-	-	-	See Table 3
t _{UC}	Time of update cycle	-	1	-	μ s	

Read/Write Timing—bq4285L ($T_A = T_{OPR}$, $V_{CC} = 3.15V \pm 0.45\%$)

Symbol	Parameter	Minimum	Typical	Maximum	Unit	Notes
t _{CYC}	Cycle time	270	-	-	ns	
t _{DSL}	DS low or $\overline{RD}/\overline{WR}$ high time	135	-	-	ns	
t _{DSH}	DS high or $\overline{RD}/\overline{WR}$ low time	90	-	-	ns	
t _{RWH}	R/\overline{W} hold time	0	-	-	ns	
t _{RWS}	R/\overline{W} setup time	15	-	-	ns	
t _{CS}	Chip select setup time	8	-	-	ns	
t _{CH}	Chip select hold time	0	-	-	ns	
t _{DHR}	Read data hold time	0	-	40	ns	
t _{DHW}	Write data hold time	0	-	-	ns	
t _{AS}	Address setup time	30	-	-	ns	
t _{AH}	Address hold time	15	-	-	ns	
t _{DAS}	Delay time, DS to AS rise	15	-	-	ns	
t _{ASW}	Pulse width, AS high	50	-	-	ns	
t _{ASD}	Delay time, AS to DS rise (RD/WR fall)	55	-	-	ns	
t _{OD}	Output data delay time from DS rise (RD fall)	-	-	100	ns	
t _{DW}	Write data setup time	50	-	-	ns	
t _{BUC}	Delay time before update	-	244	-	μs	
t _{PI}	Periodic interrupt time interval	-	-	-	-	See Table 3
t _{UC}	Time of update cycle	-	1	-	μs	

bq4285E/L

Motorola Bus Read/Write Timing—bq4285E/L (PLCC Package Only)

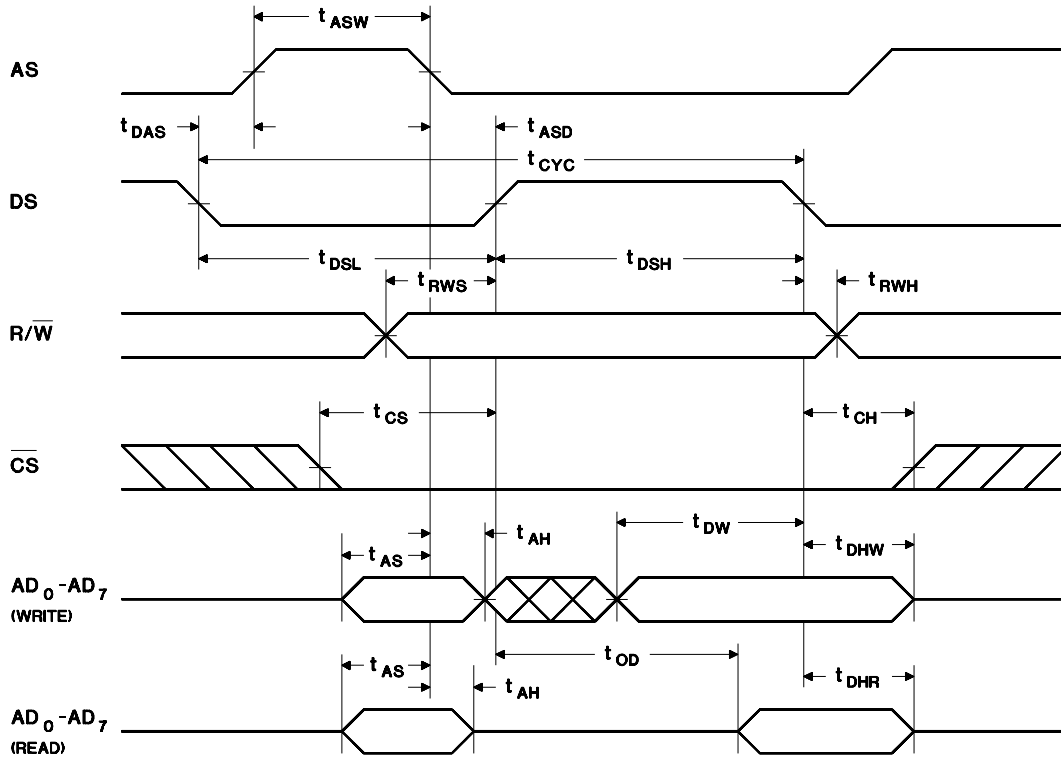

RC-4

Intel Bus Read Timing—bq4285E/L

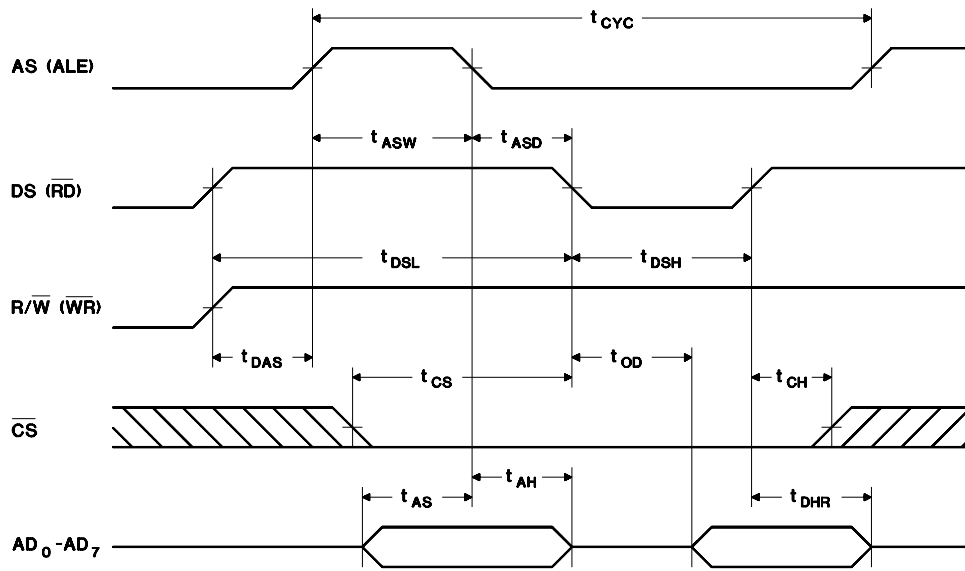

RC-6

Intel Bus Write Timing—bq4285E/L

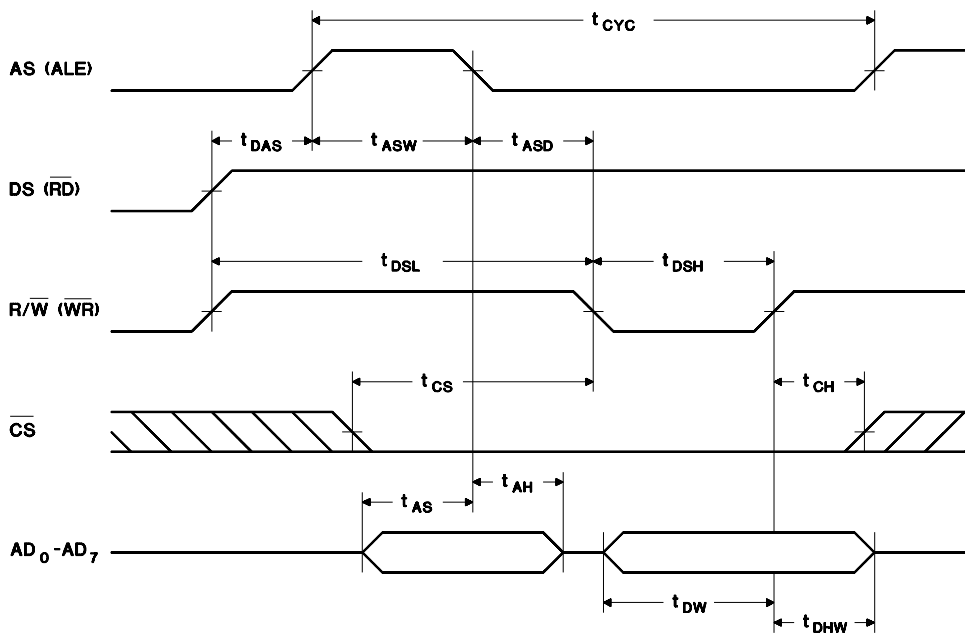

WC-6

bq4285E/L

Power-Down/Power-Up Timing—bq4285E ($T_A = T_{OPR}$)

Symbol	Parameter	Minimum	Typical	Maximum	Unit	Conditions
t_F	V_{CC} slew from 4.5V to 0V	300	-	-	μs	
t_R	V_{CC} slew from 0V to 4.5V	100	-	-	μs	
t_{CSR}	\overline{CS} at V_{IH} after power-up	20	-	200	ms	Internal write-protection period after V_{CC} passes V_{PFD} on power-up.
t_{WPT}	Write-protect time for external RAM	10	16	30	μs	Delay after V_{CC} slows down past V_{PFD} before SRAM is write-protected.
t_{CER}	Chip enable recovery time	t_{CSR}	-	t_{CSR}	ms	Time during which external SRAM is write-protected after V_{CC} passes V_{PFD} on power-up.
t_{CED}	Chip enable propagation delay to external SRAM	-	7	10	ns	

Caution: Negative undershoots below the absolute maximum rating of -0.3V in battery-backup mode may affect data integrity.

Power-Down/Power-Up Timing—bq4285E

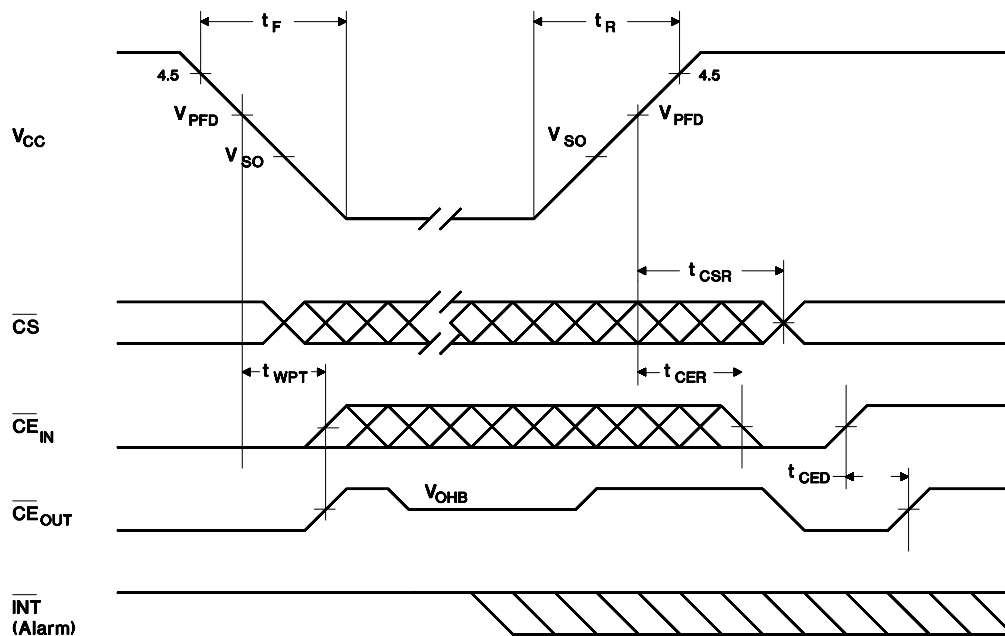

PD-13

Jan. 1999 B

Power-Down/Power-Up Timing—bq4285L ($T_A = T_{OPR}$)

Symbol	Parameter	Minimum	Typical	Maximum	Unit	Conditions
t_F	V_{CC} slew from 2.7V to 0V	300	-	-	μs	
t_R	V_{CC} slew from 0V to 2.7V	100	-	-	μs	
t_{CSR}	\overline{CS} at V_{IH} after power-up	20	-	200	ms	Internal write-protection period after V_{CC} passes V_{PFD} on power-up.
t_{WPT}	Write-protect time for external RAM	-	0	-		$V_{BC} > V_{PFD}$
		10	16	30	μs	$V_{BC} < V_{PFD}$
t_{CER}	Chip enable recovery time	t_{CSR}	-	t_{CSR}	ms	Time during which external SRAM is write-protected after V_{CC} passes V_{PFD} on power-up.
t_{CED}	Chip enable propagation delay to external SRAM	-	9	15	ns	

Caution: Negative undershoots below the absolute maximum rating of -0.3V in battery-backup mode may affect data integrity.

Power-Down/Power-Up Timing—bq4285L

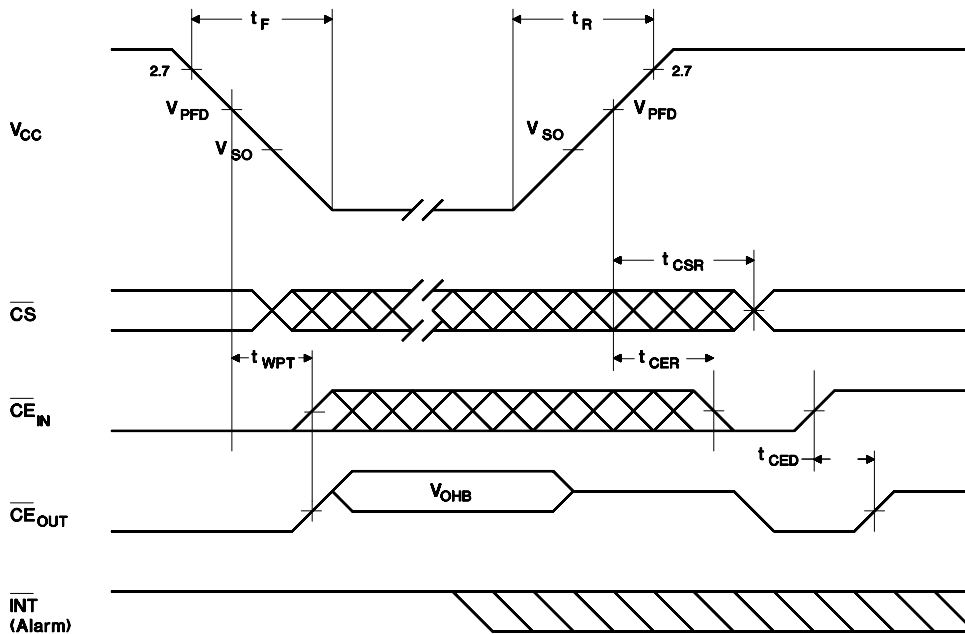

bq4285E/L

Interrupt Delay Timing—bq4285E/L ($T_A = T_{OPR}$)

Symbol	Parameter	Minimum	Typical	Maximum	Unit
t_{RSW}	Reset pulse width	5	-	-	μs
t_{IRR}	\overline{INT} release from \overline{RST}	-	-	2	μs
t_{IRD}	\overline{INT} release from DS (\overline{RD})	-	-	2	μs

Interrupt Delay Timing—bq4285E/L (PLCC Package Only)

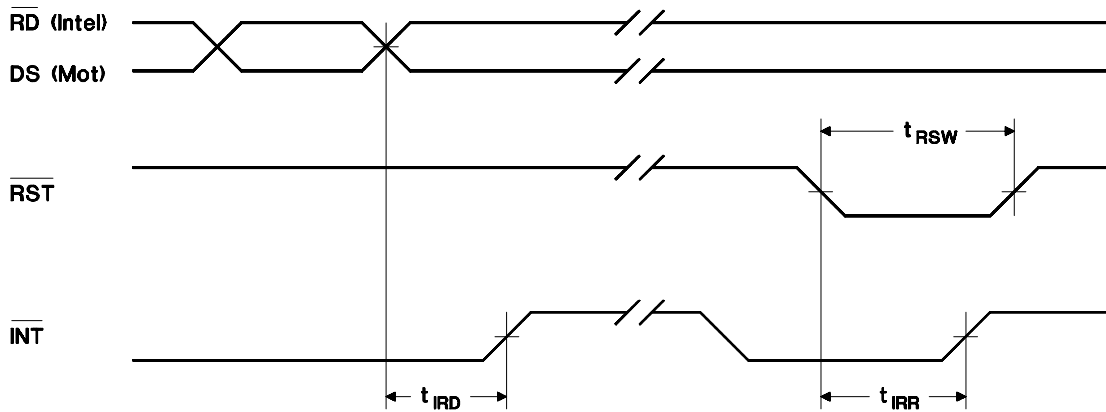

INT-1

Interrupt Delay Timing—bq4285E/L (SOIC, DIP Packages)

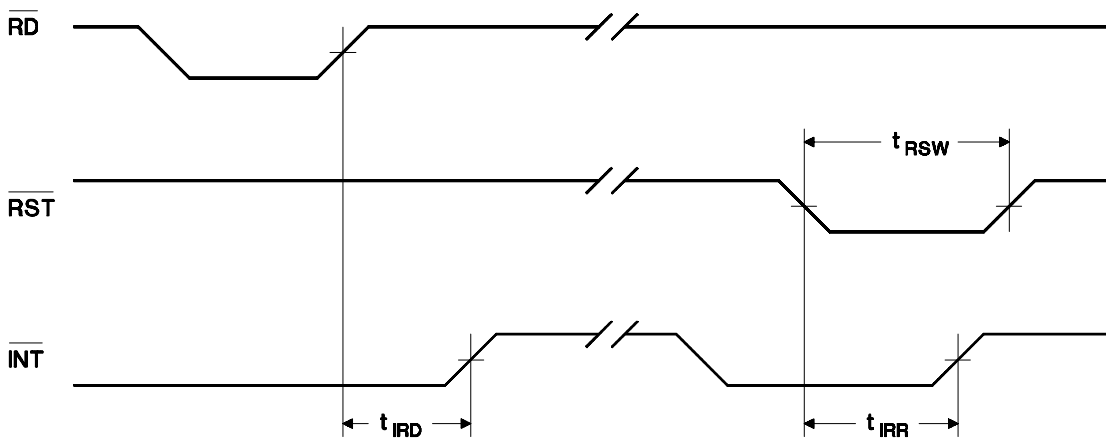

INT-4

Jan. 1999 B

P: 24-Pin DIP (0.600")

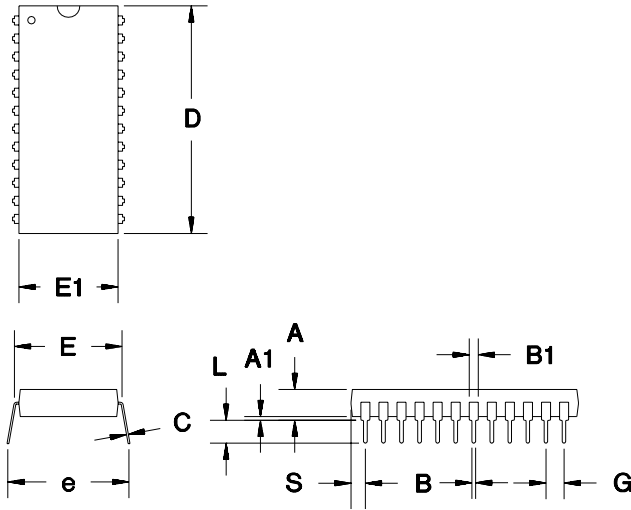

24-Pin P (0.600" DIP)

Dimension	Inches		Millimeters	
	Min.	Max.	Min.	Max.
A	0.160	0.190	4.06	4.83
A1	0.015	0.040	0.38	1.02
B	0.015	0.022	0.38	0.56
B1	0.045	0.065	1.14	1.65
C	0.008	0.013	0.20	0.33
D	1.240	1.280	31.50	32.51
E	0.600	0.625	15.24	15.88
E1	0.530	0.570	13.46	14.48
e	0.600	0.670	15.24	17.02
G	0.090	0.110	2.29	2.79
L	0.115	0.150	2.92	3.81
S	0.070	0.090	1.78	2.29

S: 24-Pin SOIC (0.300")

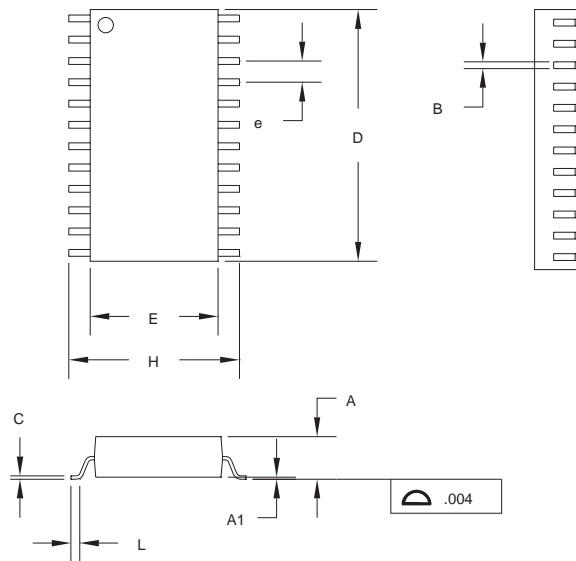

24-Pin S (0.300" SOIC)

Dimension	Inches		Millimeters	
	Min.	Max.	Min.	Max.
A	0.095	0.105	2.41	2.67
A1	0.004	0.012	0.10	0.30
B	0.013	0.020	0.33	0.51
C	0.008	0.013	0.20	0.33
D	0.600	0.615	15.24	15.62
E	0.290	0.305	7.37	7.75
e	0.045	0.055	1.14	1.40
H	0.395	0.415	10.03	10.54
L	0.020	0.040	0.51	1.02

bq4285E/bq4285L

Q: 28-Pin Quad PLCC

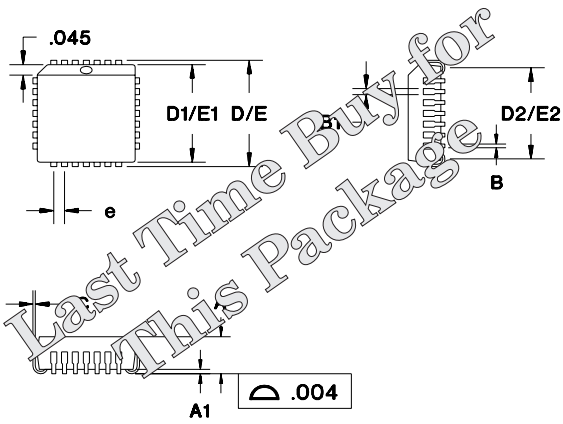

28-Pin Q (Quad PLCC)

Dimension	Inches		Millimeters	
	Min.	Max.	Min.	Max.
A	0.165	0.180	4.19	4.57
A1	0.020	-	0.51	-
B	0.012	0.021	0.30	0.53
B1	0.025	0.033	0.64	0.84
C	0.008	0.012	0.20	0.30
D	0.485	0.495	12.32	12.57
D1	0.445	0.455	11.30	11.56
D2	0.390	0.430	9.91	10.92
E	0.485	0.495	12.32	12.57
E1	0.445	0.455	11.30	11.56
E2	0.390	0.430	9.91	10.92
e	0.045	0.055	1.14	1.40

Data Sheet Revision History

Change No.	Page No.	Description	Nature of Change
1	1, 25	Package option change	Last time buy for PLCC

Notes: Change 1 = Jan. 1999 B changes from May 1994.

Ordering Information

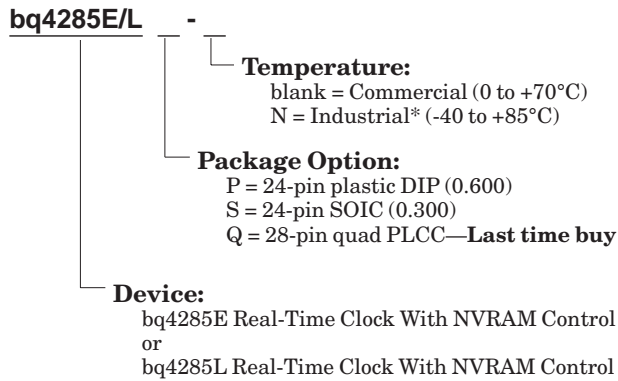

*Contact factory for availability.

IMPORTANT NOTICE

Texas Instruments and its subsidiaries (TI) reserve the right to make changes to their products or to discontinue any product or service without notice, and advise customers to obtain the latest version of relevant information to verify, before placing orders, that information being relied on is current and complete. All products are sold subject to the terms and conditions of sale supplied at the time of order acknowledgement, including those pertaining to warranty, patent infringement, and limitation of liability.

TI warrants performance of its semiconductor products to the specifications applicable at the time of sale in accordance with TI's standard warranty. Testing and other quality control techniques are utilized to the extent TI deems necessary to support this warranty. Specific testing of all parameters of each device is not necessarily performed, except those mandated by government requirements.

CERTAIN APPLICATIONS USING SEMICONDUCTOR PRODUCTS MAY INVOLVE POTENTIAL RISKS OF DEATH, PERSONAL INJURY, OR SEVERE PROPERTY OR ENVIRONMENTAL DAMAGE ("CRITICAL APPLICATIONS"). TI SEMICONDUCTOR PRODUCTS ARE NOT DESIGNED, AUTHORIZED, OR WARRANTED TO BE SUITABLE FOR USE IN LIFE-SUPPORT DEVICES OR SYSTEMS OR OTHER CRITICAL APPLICATIONS. INCLUSION OF TI PRODUCTS IN SUCH APPLICATIONS IS UNDERSTOOD TO BE FULLY AT THE CUSTOMER'S RISK.

In order to minimize risks associated with the customer's applications, adequate design and operating safeguards must be provided by the customer to minimize inherent or procedural hazards.

TI assumes no liability for applications assistance or customer product design. TI does not warrant or represent that any license, either express or implied, is granted under any patent right, copyright, mask work right, or other intellectual property right of TI covering or relating to any combination, machine, or process in which such semiconductor products or services might be or are used. TI's publication of information regarding any third party's products or services does not constitute TI's approval, warranty or endorsement thereof.