

## 18-V SUPPLY MULTI-CHANNEL GAMMA CORRECTION BUFFER

### FEATURES

- **Wide Supply Range: 4.5 V to 18 V**
- **Gamma Correction Channels: 10, 6, and 4**
- **Integrated  $V_{COM}$  Buffer**
- **Excellent Output Current Drive:**
  - **Gamma Channels:**  
> 30 mA at 0.5 V Swing to Rails(1)
  - **$V_{COM}$ :**  
> 100 mA typ at 2 V Swing to Rails(1)
- **Large Capacitive Load Drive Capability**
- **Rail-to-Rail Output**
- **PowerPAD™ Package**
- **Low-Power/Channel: < 500  $\mu$ A**
- **High ESD Rating: 8 kV HBM, 2 kV CDM, 300 V MM**
- **Specified for  $-25^{\circ}\text{C}$  to  $+85^{\circ}\text{C}$**

(1) See Typical Characteristic curves for details.

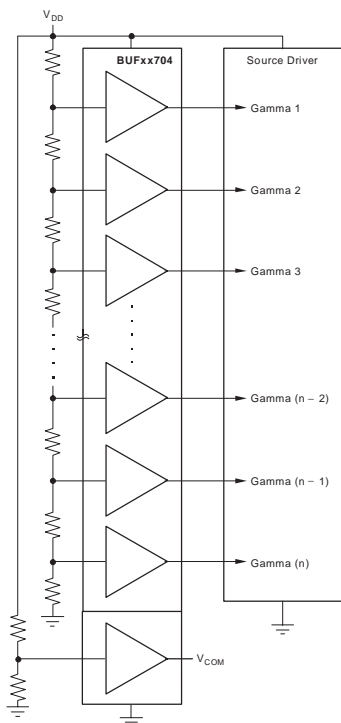

### DESCRIPTION

The BUFxx704 are a series of multi-channel buffers targeted towards gamma correction in high-resolution LCD panels. They are pin-compatible with the existing BUFxx702 and BUFxx703 family and operate at higher supply voltages up to 18 V (19 V absolute max). The higher supply voltage enables faster response times and brighter images in large-screen LCD panels. This is especially important in LCD TV applications.

The number of gamma correction channels required depends on a variety of factors and differs greatly from design to design. Therefore, 10, 6, and 4 channel options are offered. For additional space and cost savings, a  $V_{COM}$  channel with > 100mA drive capability is integrated into the BUF11704, BUF07704, and BUF05704.

The BUF11704, BUF07704, BUF06704, and BUF05704 are available in the TSSOP-28, TSSOP-20, TSSOP-16, and TSSOP-14 PowerPAD packages for dramatically increased power dissipation capability. This way, a large number of channels can be handled safely in one package.

A flow-through pin out has been adopted to allow simple PCB routing and maintain the cost-effectiveness of this solution. All inputs and outputs of the BUFxx704 incorporate internal ESD protection circuits that prevent functional failures at voltages up to 8 kV (HBM), 2 kV (CDM), and 300 V (MM).

MODEL	GAMMA CHANNELS	$V_{COM}$ CHANNELS
BUF11704	10	1
BUF07704	6	1
BUF06704	6	0
BUF05704	4	1



Please be aware that an important notice concerning availability, standard warranty, and use in critical applications of Texas Instruments semiconductor products and disclaimers thereto appears at the end of this data sheet.

PowerPAD is a trademark of Texas Instruments Incorporated. All other trademarks are the property of their respective owners.

## ABSOLUTE MAXIMUM RATINGS

over operating free-air temperature range unless otherwise noted<sup>(1)</sup>

PARAMETERS	BUFxx704	UNIT
Supply Voltage, $V_{DD}$ <sup>(2)</sup>	19	V
Input Voltage Range, $V_I$	$\pm V_{DD}$	
Continuous Total Power Dissipation	See Dissipation Rating Table	
Operating Free-Air Temperature Range, $T_A$	-25 to 85	°C
Maximum Junction Temperature, $T_J$	125	°C
Storage Temperature Range, $T_{STG}$	-65 to 150	°C
Lead Temperature 1.6mm (1/16 inch) from Case for 10s	260	°C
ESD Rating:		
Human Body Model (HBM)	8	kV
Charged-Device Model (CDM)	2	kV
Machine Model (MM)	300	V

(1) Stresses beyond those listed under absolute maximum ratings may cause permanent damage to the device. These are stress ratings only, and functional operation of the device at these or any other conditions beyond those indicated under recommended operating conditions is not implied. Exposure to absolute-maximum-rated conditions for extended periods may affect device reliability.

(2) All voltage values are with respect to GND.

## ORDERING INFORMATION<sup>(1)</sup>

PRODUCT	PACKAGE-LEAD	PACKAGE MARKING
BUF05704	TSSOP-14	BUF05704
BUF06704	TSSOP-16	BUF06704
BUF07704	TSSOP-20	BUF07704
BUF11704	TSSOP-28	BUF11704

(1) For the most current package and ordering information, see the Package Option Addendum located at the end of this data sheet.

## DISSIPATION RATING TABLE

PACKAGE TYPE	PACKAGE DESIGNATOR	$\theta_{JC}$ <sup>(1)</sup> (°C/W)	$\theta_{JA}$ <sup>(1)</sup> (°C/W)	$T_A \leq 25^\circ\text{C}$ POWER RATING
TSSOP-28	PWP (28)	0.72	27.9	3.58 W
TSSOP-20	PWP (20)	1.40	32.63	3.06 W
TSSOP-16	PWP (16)	2.07	36.51	2.74
TSSOP-14	PWP (14)	2.07	37.47	2.67

(1) PowerPAD attached to PCB, 0 lfm airflow, and 76mm x 76mm copper area.

## RECOMMENDED OPERATING CONDITIONS

	MIN	NOM	MAX	UNIT
Supply Voltage, $V_{DD}$	7		18	V
Operating Free-Air Temperature, $T_A$	-25		+85	°C

## EQUIVALENT SCHEMATICS OF INPUTS AND OUTPUTS

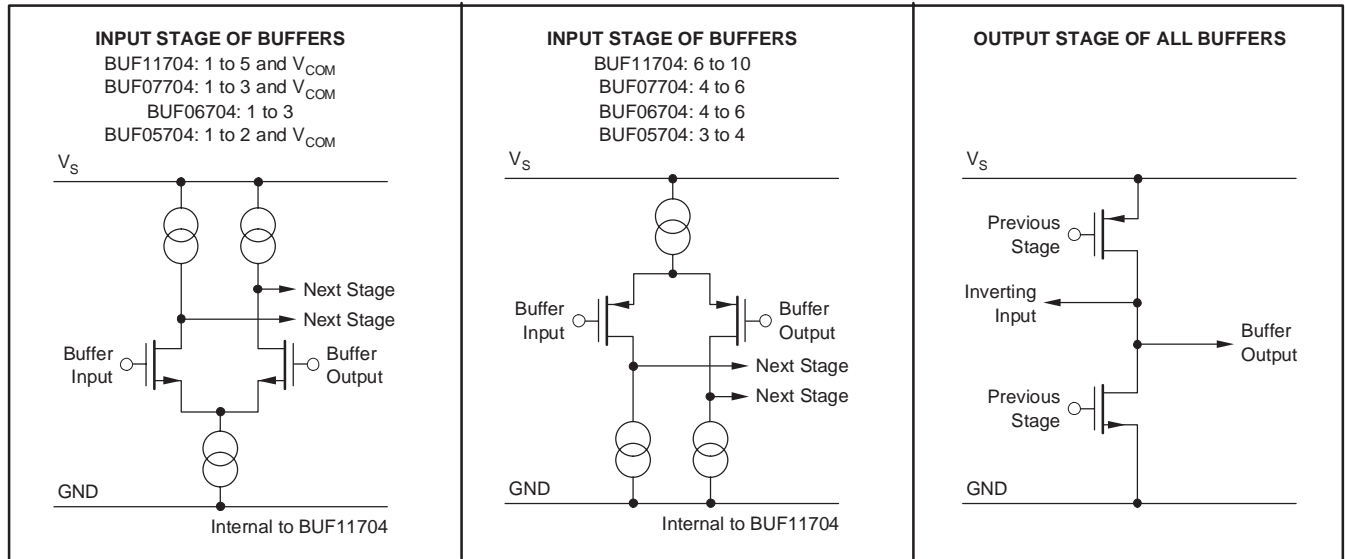

## ELECTRICAL CHARACTERISTICS: BUFxx704

Over operating free-air temperature range,  $V_{DD} = 18\text{ V}$ ,  $T_A = 25^\circ\text{C}$ , unless otherwise noted.

PARAMETER			TEST CONDITIONS	$T_A$	MIN	TYP	MAX	UNIT
$V_{IO}$	Input offset voltage	Gamma buffers	$V_I = 9\text{ V}$	25°C	-1	20		mV
				Full range <sup>(1)</sup>		20		
		$V_{COM}$		25°C	-1	30		
				Full range <sup>(1)</sup>		30		
$I_{IB}$	Input bias current		$V_I = V_{DD}/2$	25°C		1		pA
				Full range <sup>(1)</sup>		200		
PSRR	Power-Supply Rejection Ratio		$V_{DD} = 4.5\text{ V to }19\text{ V}$	25°C	62	80		dB
				Full range <sup>(1)</sup>	60			
Buffer gain			$V_I = 5\text{ V}$	25°C		0.9995		V/V
BW_3dB	3dB bandwidth	Gamma buffers $V_{COM}$ buffer	$C_L = 100\text{ pF}$ , $R_L = 2\text{ k}\Omega$	25°C		1 0.6		MHz
SR	Slew rate	Gamma buffers $V_{COM}$ buffer	$C_L = 100\text{ pF}$ , $R_L = 2\text{ k}\Omega$ $V_{IN} = 2\text{ V to }16\text{ V}$	25°C		1.6 4.6		$\text{V}/\mu\text{s}$
					Crosstalk	$V_{IP-P} = 6\text{ V}$ , $f = 1\text{ kHz}$	25°C	

(1) Full range is  $-25^\circ\text{C}$  to  $85^\circ\text{C}$ .

**ELECTRICAL CHARACTERISTICS: BUF11704**

Over operating free-air temperature range,  $V_{DD} = 18\text{ V}$ ,  $T_A = 25^\circ\text{C}$ , unless otherwise noted.

PARAMETER		TEST CONDITIONS	$T_A$ (1)	MIN	TYP	MAX	UNIT
$I_{DD}$	Supply current	ALL	$V_O = V_{DD}/2$ No Load	25°C	5	9.0	mA
				Full range		9.0	
Common-mode input range	Buffers 1-5		25°C	1	$V_{DD}$		V
	Buffers 6-10			GND	$V_{DD} - 1$		
	VCOM buffer			1	$V_{DD}$		
Load regulation	VCOM buffer sinking	$I_O = 1\text{ mA to }100\text{ mA}$ , $V_{IN} = 2\text{ V}$	25°C	1	5		mV/mA
			Full range		5		
	VCOM buffer sourcing	$I_O = -1\text{ mA to }-100\text{ mA}$ $V_{IN} = 16\text{ V}$	25°C	1	5		
			Full range		5		
	Buffers 1-10 sinking	$I_O = 1\text{ mA to }10\text{ mA}$ $V_{IN} = 1\text{ V}$	25°C	1	5		
			Full range		5		
	Buffers 1-10 sourcing	$I_O = -1\text{ mA to }-10\text{ mA}$ $V_{IN} = 17\text{ V}$	25°C	1	5		
			Full range		5		
VOH1-5	High-level output voltage	Buffers 1-5	$V_{IN} = 18\text{ V}$ $I_{SOURCE} = 10\text{ mA}$	25°C	17.85	17.9	V
VOH6-10		Buffers 6-10	$V_{IN} = 17\text{ V}$ $I_{SINK} = 10\text{ mA}$	25°C	17	17.15	V
		$V_{IN} = 17\text{ V}$ $I_{SOURCE} = 10\text{ mA}$	16.85		17		
VOL1-5	Low-level output voltage	Buffers 1-5	$V_{IN} = 1\text{ V}$ $I_{SINK} = 10\text{ mA}$	25°C	1.0	1.15	V
			$V_{IN} = 1\text{ V}$ $I_{SOURCE} = 10\text{ mA}$		0.85	1.0	
VOL6-10		Buffers 6-10	$V_{IN} = 0\text{ V}$ $I_{SINK} = 10\text{ mA}$	25°C	0	0.15	V
VOHCOM	High-level output voltage	VCOM buffer	$V_{IN} = 16\text{ V}$ $I_{SINK} = 100\text{ mA}$	25°C	16	16.15	V
			$V_{IN} = 16\text{ V}$ $I_{SOURCE} = 100\text{ mA}$		15.85	16	
VOLCOM	Low-level output voltage	VCOM buffer	$V_{IN} = 2\text{ V}$ $I_{SINK} = 100\text{ mA}$	25°C	2	2.15	V
			$V_{IN} = 2\text{ V}$ $I_{SOURCE} = 100\text{ mA}$		1.85	2	

(1) Full range is  $-25^\circ\text{C}$  to  $85^\circ\text{C}$ .

**ELECTRICAL CHARACTERISTICS: BUF07704**

 Over operating free-air temperature range,  $V_{DD} = 18\text{ V}$ ,  $T_A = 25^\circ\text{C}$ , unless otherwise noted.

PARAMETER		TEST CONDITIONS	$T_A^{(1)}$	MIN	TYP	MAX	UNIT
$I_{DD}$	Supply current	ALL	$V_O = V_{DD}/2$ No Load	25°C	5	7.5	mA
				Full range		7.5	
Common-mode input range	Buffers 1-3		25°C	1		$V_{DD}$	V
	Buffers 4-6			GND	$V_{DD} - 1$		
	$V_{COM}$ buffer			1	$V_{DD}$		
Load regulation	$V_{COM}$ buffer sinking	$I_O = 1\text{ mA to }100\text{ mA}$ $V_{IN} = 2\text{ V}$	25°C	1	5	mV/mA	
			Full range		5		
	$V_{COM}$ buffer sourcing	$I_O = -1\text{ mA to }-100\text{ mA}$ $V_{IN} = 16\text{ V}$	25°C	1	5		
			Full range		5		
	Buffers 1-6 sinking	$I_O = 1\text{ mA to }10\text{ mA}$ $V_{IN} = 1\text{ V}$	25°C	1	5		
			Full range		5		
Buffers 1-6 sourcing	$I_O = -1\text{ mA to }-10\text{ mA}$ $V_{IN} = 17\text{ V}$	25°C	1	5			
		Full range		5			
$V_{OH1-3}$	High-level output voltage	Buffers 1-3	$V_{IN} = 18\text{ V}$ $I_{SOURCE} = 10\text{ mA}$	25°C	17.85	17.9	V
$V_{OH4-6}$		Buffers 4-6	$V_{IN} = 17\text{ V}$ $I_{SINK} = 10\text{ mA}$	25°C	17	17.15	V
	$V_{IN} = 17\text{ V}$ $I_{SOURCE} = 10\text{ mA}$		16.85		17		
$V_{OL1-3}$	Low-level output voltage	Buffers 1-3	$V_{IN} = 1\text{ V}$ $I_{SINK} = 10\text{ mA}$	25°C	1.0	1.15	V
			$V_{IN} = 1\text{ V}$ $I_{SOURCE} = 10\text{ mA}$		0.85	1.0	
$V_{OL4-6}$		Buffers 4-6	$V_{IN} = 0\text{ V}$ $I_{SINK} = 10\text{ mA}$	25°C	0	0.15	V
$V_{OHCOM}$	High-level output voltage	$V_{COM}$ buffer	$V_{IN} = 16\text{ V}$ $I_{SINK} = 100\text{ mA}$	25°C	16	16.15	V
			$V_{IN} = 16\text{ V}$ $I_{SOURCE} = 100\text{ mA}$		15.85	16	
$V_{OLCOM}$	Low-level output voltage	$V_{COM}$ buffer	$V_{IN} = 2\text{ V}$ $I_{SINK} = 100\text{ mA}$	25°C	2	2.15	V
			$V_{IN} = 2\text{ V}$ $I_{SOURCE} = 100\text{ mA}$		1.85	2	

 (1) Full range is  $-25^\circ\text{C}$  to  $85^\circ\text{C}$ .

**ELECTRICAL CHARACTERISTICS: BUF06704**

Over operating free-air temperature range,  $V_{DD} = 18\text{ V}$ ,  $T_A = 25^\circ\text{C}$ , unless otherwise noted.

PARAMETER		TEST CONDITIONS	$T_A^{(1)}$	MIN	TYP	MAX	UNIT	
$I_{DD}$	Supply current	ALL	$V_O = V_{DD}/2$ No Load	25°C	5	7.5	mA	
				Full range		7.5		
Common-mode input range		Buffers 1-3	25°C	1	$V_{DD}$		V	
		Buffers 4-6		GND	$V_{DD} - 1$			
Load regulation		Buffers 1-6 sinking	$I_O = 1\text{ mA to }10\text{ mA}$ $V_{IN} = 1\text{ V}$	25°C	1	5	mV/mA	
				Full range		5		
		Buffers 1-6 sourcing	$I_O = -1\text{ mA to }-10\text{ mA}$ $V_{IN} = 17\text{ V}$	25°C	1	5		
				Full range		5		
$V_{OH1-3}$	High-level output voltage	Buffers 1-3	$V_{IN} = 18\text{ V}$ $I_{SOURCE} = 10\text{ mA}$	25°C	17.85	17.9	V	
$V_{OH4-6}$		Buffers 4-6	$V_{IN} = 17\text{ V}$ $I_{SINK} = 10\text{ mA}$	25°C		17	17.15	V
	$V_{IN} = 17\text{ V}$ $I_{SOURCE} = 10\text{ mA}$		16.85		17			
$V_{OL1-3}$	Low-level output voltage	Buffers 1-3	$V_{IN} = 1\text{ V}$ $I_{SINK} = 10\text{ mA}$	25°C		1.0	1.15	V
			$V_{IN} = 1\text{ V}$ $I_{SOURCE} = 10\text{ mA}$		0.85	1.0		
$V_{OL4-6}$		Buffers 4-6	$V_{IN} = 0\text{ V}$ $I_{SINK} = 10\text{ mA}$	25°C		0	0.15	V

(1) Full range is  $-25^\circ\text{C}$  to  $85^\circ\text{C}$ .

**ELECTRICAL CHARACTERISTICS: BUF05704**

 Over operating free-air temperature range,  $V_{DD} = 18\text{ V}$ ,  $T_A = 25^\circ\text{C}$ , unless otherwise noted.

PARAMETER		TEST CONDITIONS	$T_A^{(1)}$	MIN	TYP	MAX	UNIT
$I_{DD}$	Supply current	ALL	$V_O = V_{DD}/2$ No Load	25°C	5	7.5	mA
				Full range		7.5	
Common-mode input range	Buffers 1-2		25°C	1		$V_{DD}$	V
	Buffers 3-4			GND	$V_{DD} - 1$		
	$V_{COM}$ buffer			1	$V_{DD}$		
Load regulation	$V_{COM}$ buffer sinking	$I_O = 1\text{ mA to }100\text{ mA}$ $V_{IN} = 2\text{ V}$	25°C	1	5	mV/mA	
			Full range		5		
	$V_{COM}$ buffer sourcing	$I_O = -1\text{ mA to }-100\text{ mA}$ $V_{IN} = 16\text{ V}$	25°C	1	5		
			Full range		5		
	Buffers 1-4 sinking	$I_O = 1\text{ mA to }10\text{ mA}$ $V_{IN} = 1\text{ V}$	25°C	1	5		
			Full range		5		
Buffers 1-4 sourcing	$I_O = -1\text{ mA to }-10\text{ mA}$ $V_{IN} = 17\text{ V}$	25°C	1	5			
		Full range		5			
$V_{OH1-3}$	High-level output voltage	Buffers 1-2	$V_{IN} = 18\text{ V}$ $I_{SOURCE} = 10\text{ mA}$	25°C	17.85	17.9	V
$V_{OH4-6}$		Buffers 3-4	$V_{IN} = 17\text{ V}$ $I_{SINK} = 10\text{ mA}$	25°C	17	17.15	V
	$V_{IN} = 17\text{ V}$ $I_{SOURCE} = 10\text{ mA}$		16.85		17		
$V_{OL1-3}$	Low-level output voltage	Buffers 1-2	$V_{IN} = 1\text{ V}$ $I_{SINK} = 10\text{ mA}$	25°C	1.0	1.15	V
			$V_{IN} = 1\text{ V}$ $I_{SOURCE} = 10\text{ mA}$		0.85	1.0	
$V_{OL4-6}$		Buffers 3-4	$V_{IN} = 0\text{ V}$ $I_{SINK} = 10\text{ mA}$	25°C	0	0.15	V
$V_{OHCOM}$	High-level output voltage	$V_{COM}$ buffer	$V_{IN} = 16\text{ V}$ $I_{SINK} = 100\text{ mA}$	25°C	16	16.15	V
			$V_{IN} = 16\text{ V}$ $I_{SOURCE} = 100\text{ mA}$		15.85	16	
$V_{OLCOM}$	Low-level output voltage	$V_{COM}$ buffer	$V_{IN} = 2\text{ V}$ $I_{SINK} = 100\text{ mA}$	25°C	2	2.15	V
			$V_{IN} = 2\text{ V}$ $I_{SOURCE} = 100\text{ mA}$		1.85	2	

 (1) Full range is  $-25^\circ\text{C}$  to  $85^\circ\text{C}$ .

**BUF11704 Pin Configuration**

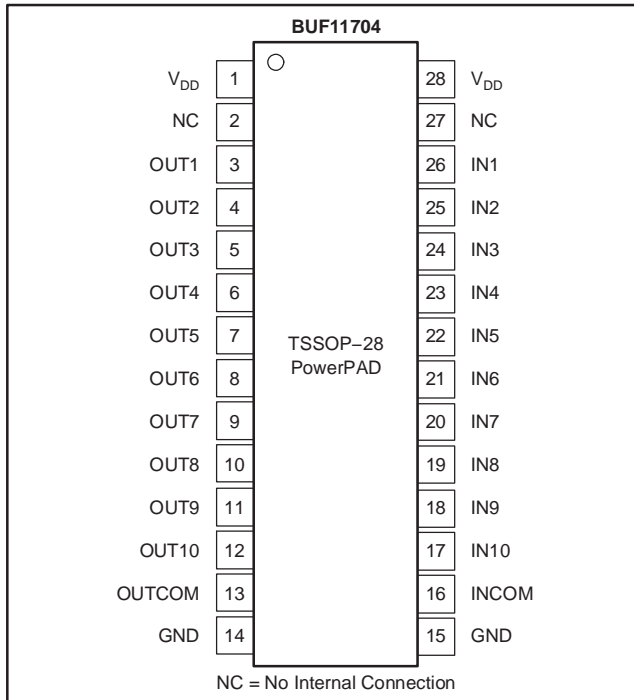

**BUF07704 Pin Configuration**

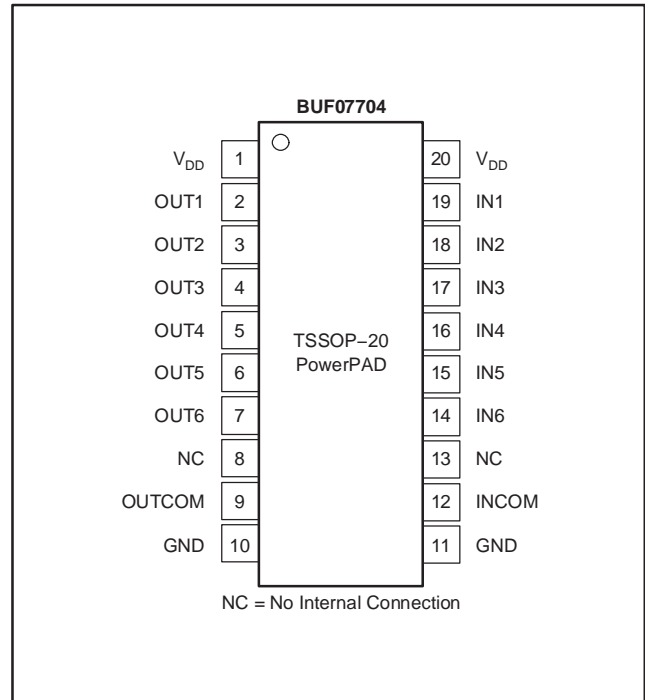

**BUF06704 Pin Configuration**

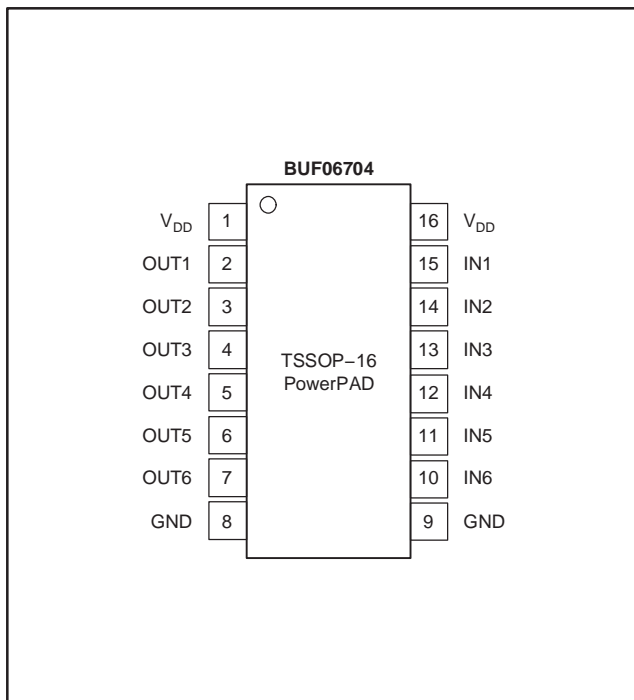

**BUF05704 Pin Configuration**

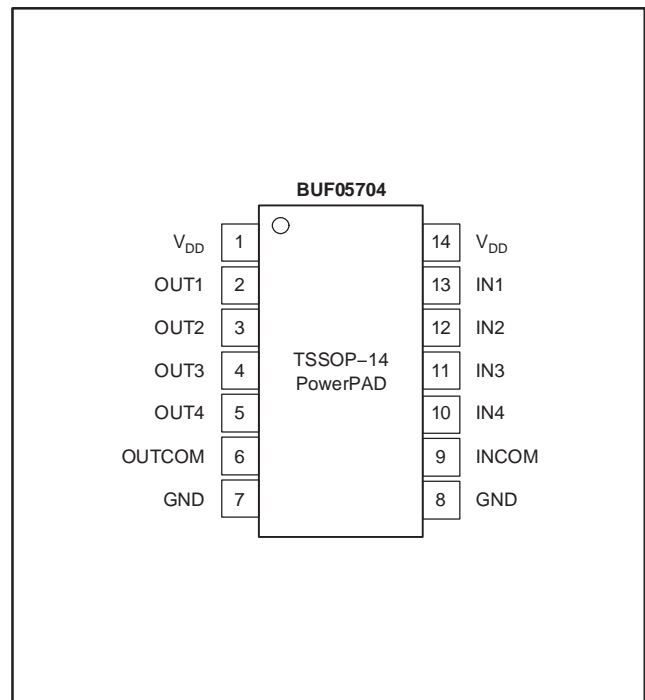

TYPICAL CHARACTERISTICS

DC CURVES

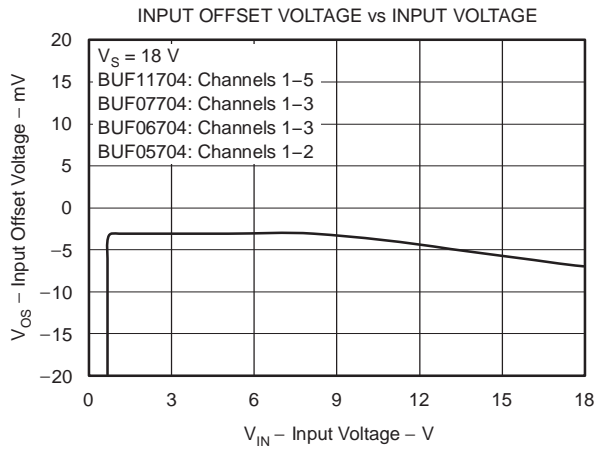

Figure 1

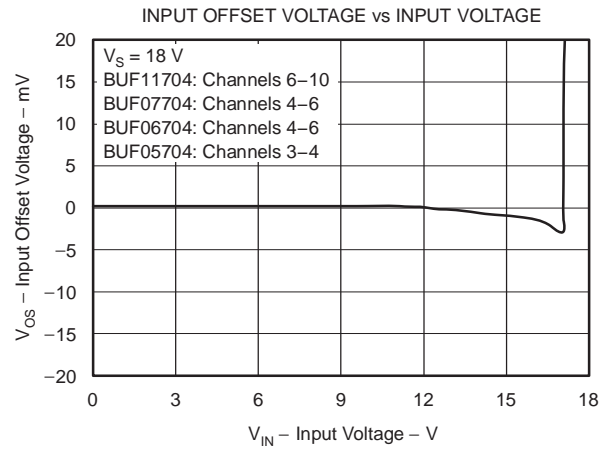

Figure 2

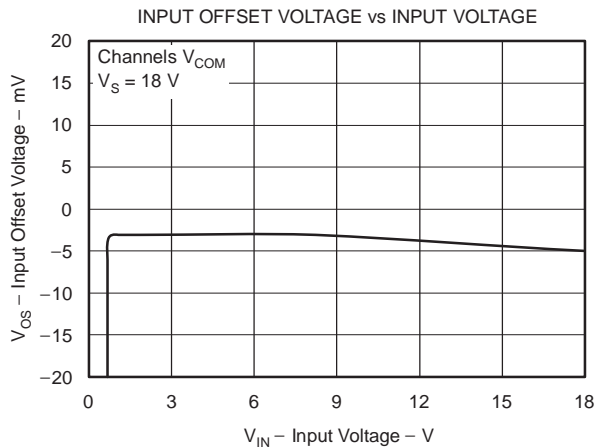

Figure 3

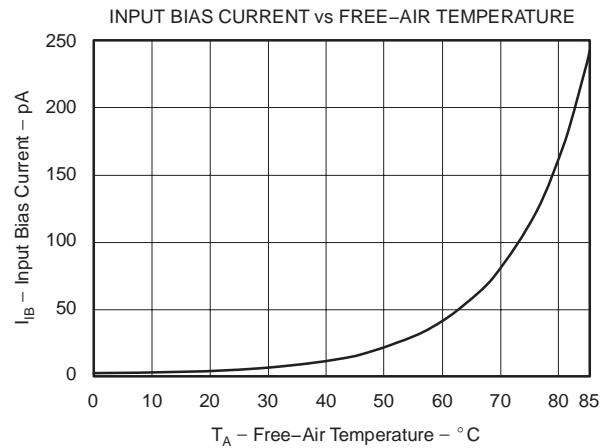

Figure 4

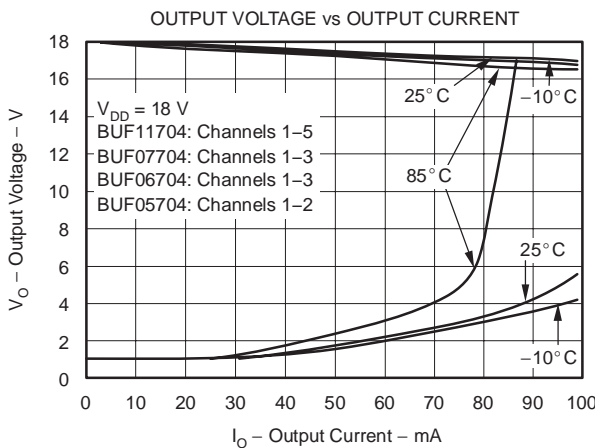

Figure 5

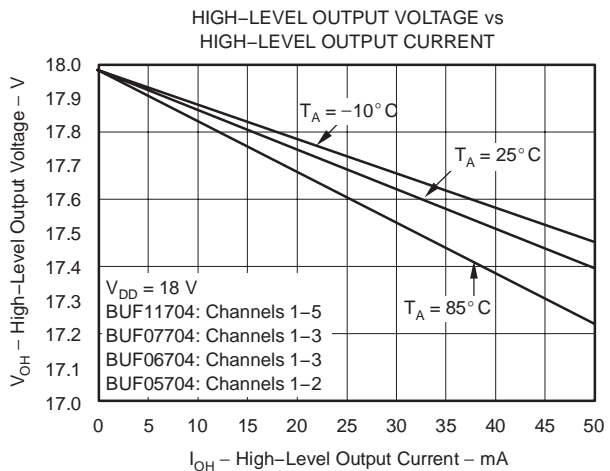

Figure 6

TYPICAL CHARACTERISTICS

DC CURVES (continued)

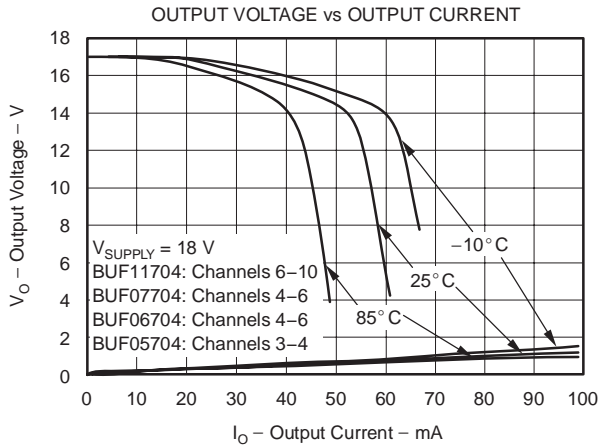

Figure 7

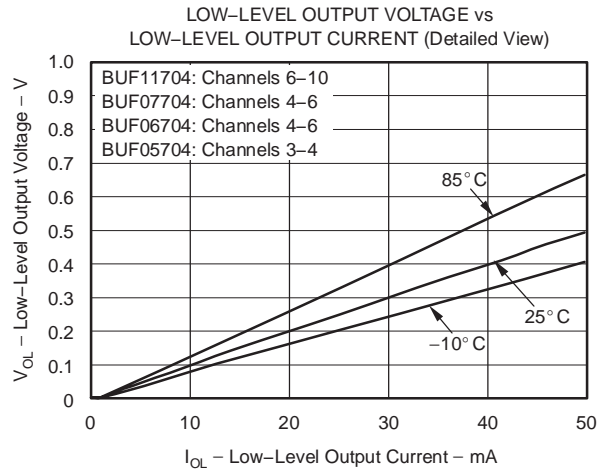

Figure 8

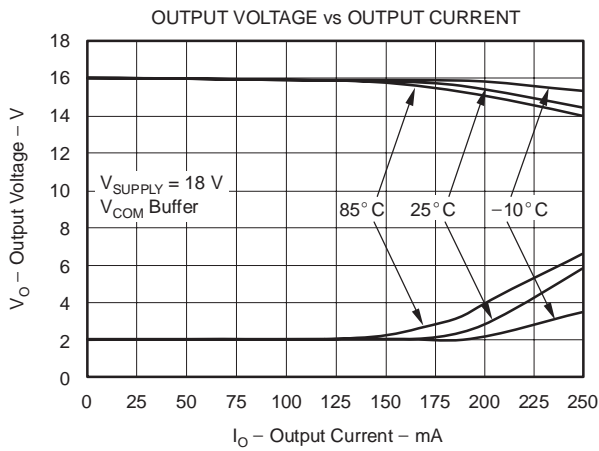

Figure 9

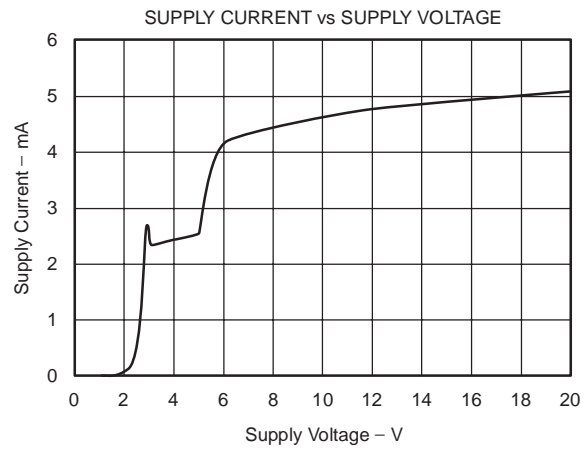

Figure 10

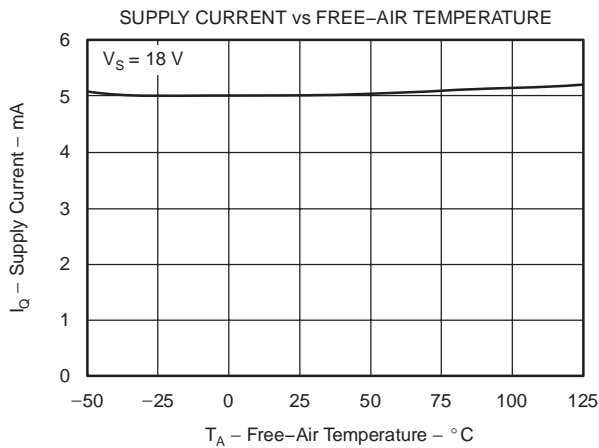

Figure 11

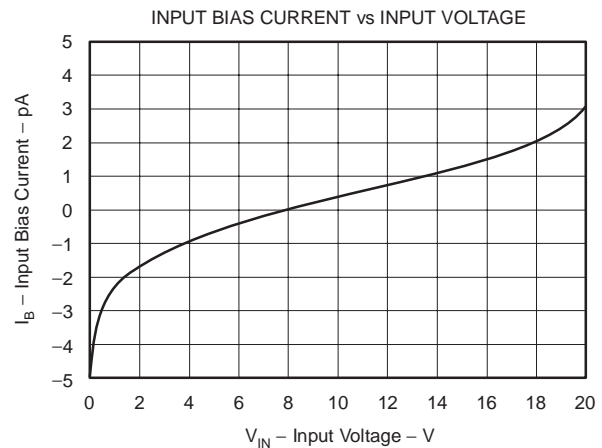
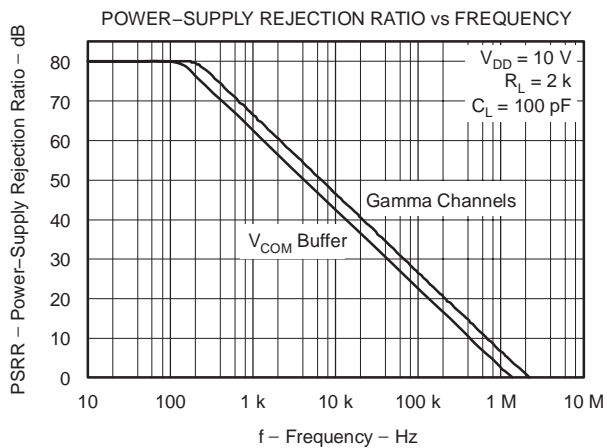

Figure 12

**TYPICAL CHARACTERISTICS**

**AC CURVES**



**Figure 13**

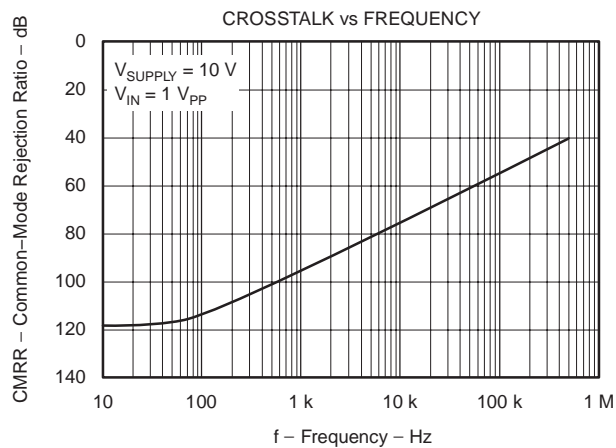

**Figure 14**

TYPICAL CHARACTERISTICS

SMALL- AND LARGE-SIGNAL WAVEFORM CURVES

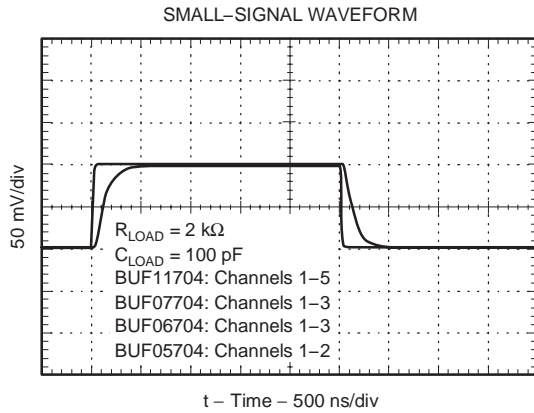

Figure 15

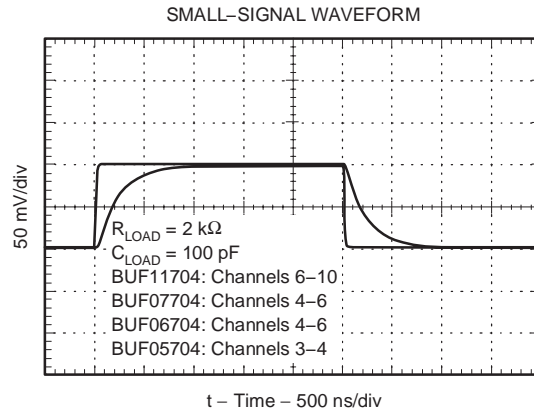

Figure 16

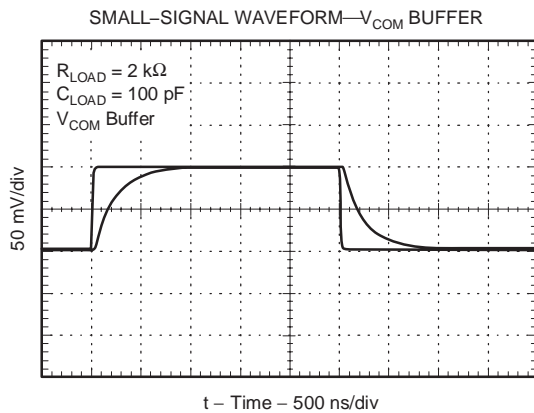

Figure 17

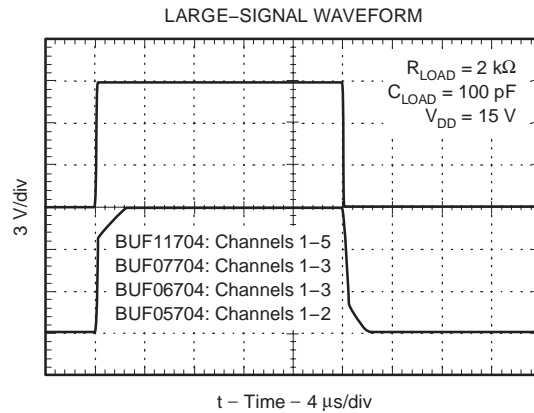

Figure 18

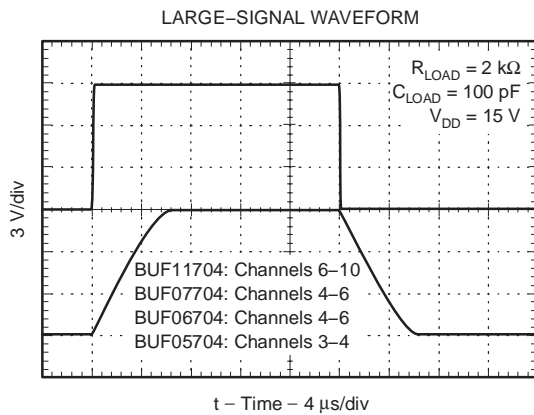

Figure 19

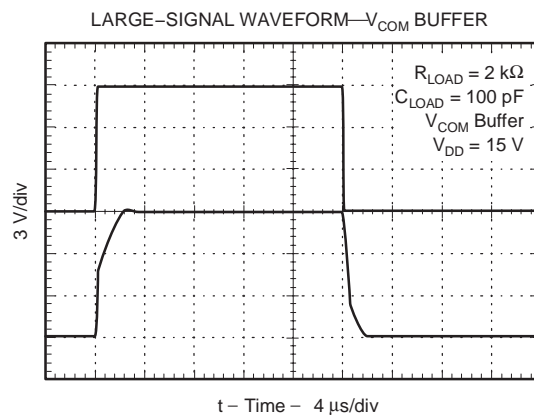
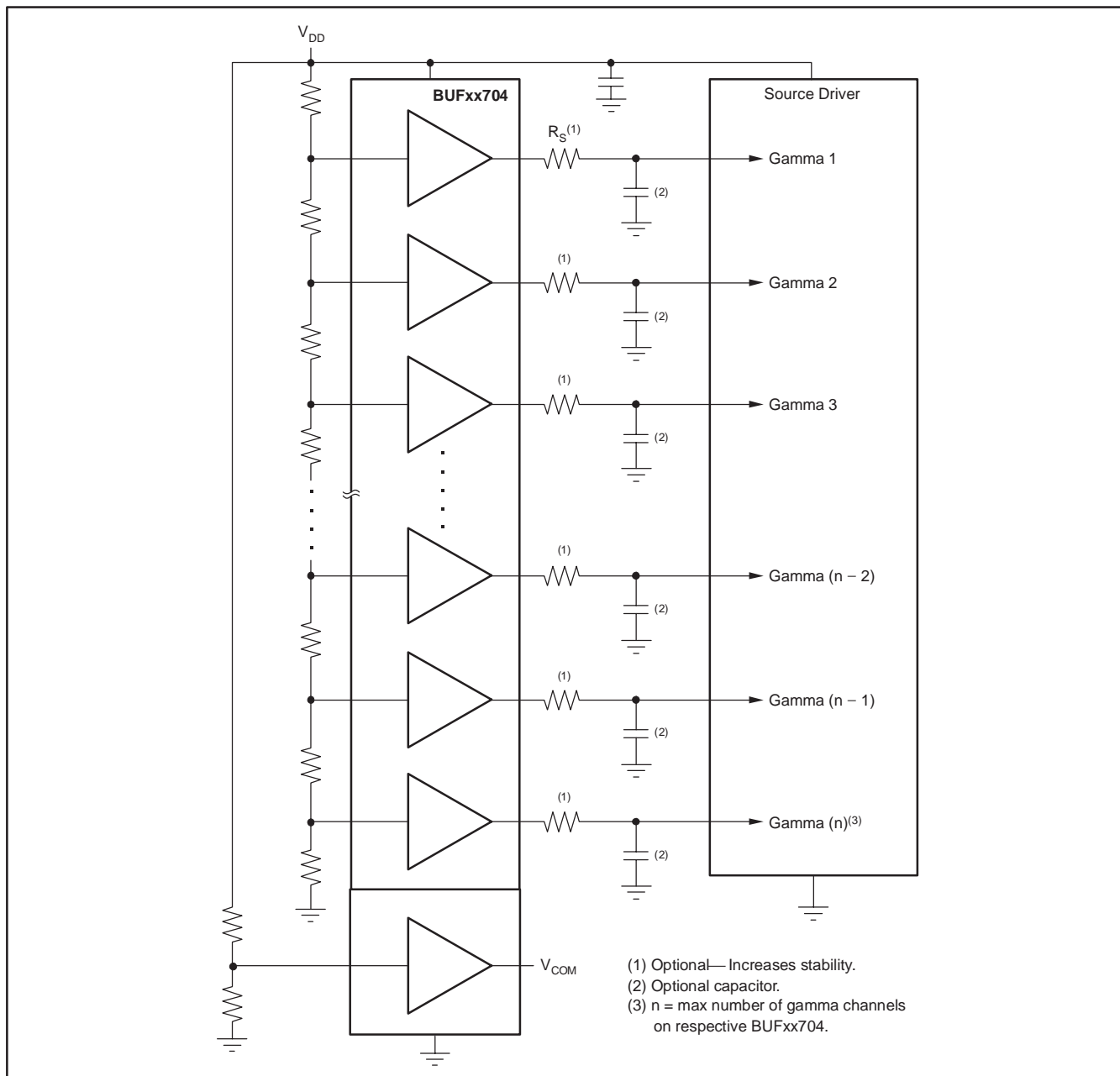

Figure 20

## APPLICATION INFORMATION

The requirements on the number of gamma correction channels vary greatly from panel to panel. Therefore, the BUFxx704 series of gamma correction buffers offers different channel combinations. The BUF11704 offers 10 gamma channels plus one  $V_{COM}$  channel, whereas the BUF07704 provides six gamma channels plus one  $V_{COM}$ . The  $V_{COM}$  channel on both models can be used to drive the  $V_{COM}$  node on the LCD panel.

Gamma correction voltages are often generated using a simple resistor ladder, as shown in Figure 21. The BUFxx704 buffers the various nodes on the gamma correction resistor ladder. The low output impedance of the BUFxx704 forces the external gamma correction voltage on the respective reference node of the LCD source driver. Figure 21 shows an example of the BUFxx704 in a typical block diagram driving an LCD source driver with 10- or 6-channel gamma correction with 10- or 6-channel gamma correction reference inputs.



**Figure 21. LCD Source Driver Typical Block Diagram**

**ESD RATINGS**

The BUFxx704 has excellent ESD performance: 8 kV HBM; 2 kV CDM; and 300 V MM. These ESD ratings allow for increased manufacturability, fewer production failures, and higher reliability.

**INPUT VOLTAGE RANGE GAMMA BUFFERS**

Figure 22 shows a typical gamma correction curve with 10 gamma correction reference points (GMA1 through GMA10). As can be seen from this curve, the voltage requirements for each buffer vary greatly. The swing capability of the input stages of the various buffers is carefully matched to the application. Using the example of the BUF11704 with 10 gamma correction channels, buffers 1 to 5 have input stages that include  $V_{DD}$ , but will only swing within 1 V to GND. Buffers 1 through 5 have only a single NMOS input stage. Buffers 6 through 10 have only a single PMOS input stage. The input range of the PMOS input stage includes GND.

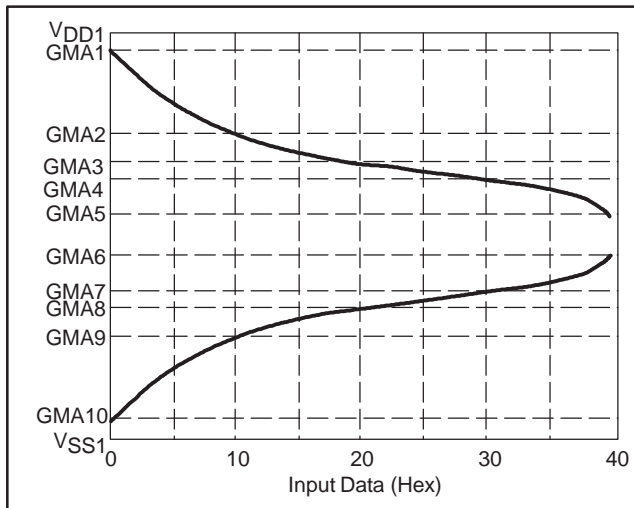

**Figure 22. Gamma Correction Curve**

**OUTPUT VOLTAGE SWING GAMMA BUFFERS**

The output stages have been designed to match the characteristic of the input stage. Once again, using the example of the BUF11704, this means that the output stage of buffers 1 to 5 swing very close to  $V_{DD}$ , typically  $V_{CC} - 100\text{ mV}$  at 10 mA; its ability to swing to GND is limited. Buffers 6 through 10 swing closer to GND than  $V_{DD}$ . Buffers 6 to 10 are designed to swing very close to GND; typically,  $GND + 100\text{ mV}$  at a 10 mA load current. See the Typical Characteristics for more details. This approach significantly reduces the silicon area and cost of the whole solution. However, due to

this architecture, the correct buffer needs to be connected to the correct gamma correction voltage. Connect buffer 1 to the gamma voltage closest to  $V_{DD}$ , and buffers 2 through 5 to the following voltages. Buffer 10 should be connected to the gamma correction voltage closest to GND (or the negative rail), and buffers 9 through 6 to the following higher voltages.

**COMMON BUFFER ( $V_{COM}$ )**

The common buffer output of the BUFxx704 has a greater output drive capability than the gamma buffers to meet the heavier current demands of driving the common node of the LCD panel. The common buffer output was also designed to drive heavier capacitive loads. Excellent output swing is possible with high currents ( $> 100\text{ mA}$ ), as shown in Figure 23.

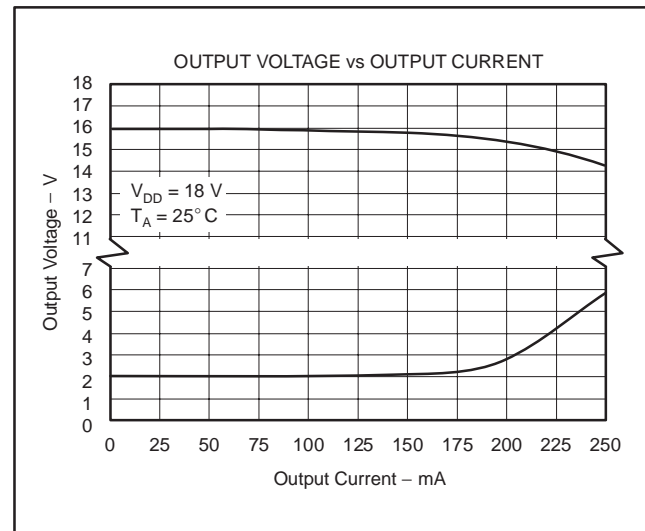

**Figure 23.  $V_{COM}$  Output Drive Capability**

**CAPACITIVE LOAD DRIVE**

The BUFxx704 has been designed to be able to sink/source large dc currents. Its output stage has been designed to deliver output current transients with little disturbance of the output voltage. However, there are times when very fast current pulses are required. Therefore, in LCD source driver buffer applications, it is quite normal for capacitors to be placed at the outputs of the reference buffers. These capacitors improve the transient load regulation and will typically vary from 100 pF and more. The BUFxx704 gamma buffers were designed to drive capacitances in excess of 100 pF. The output is able to swing within 150 mV of the rails on 10 mA of output current, see Figure 24.

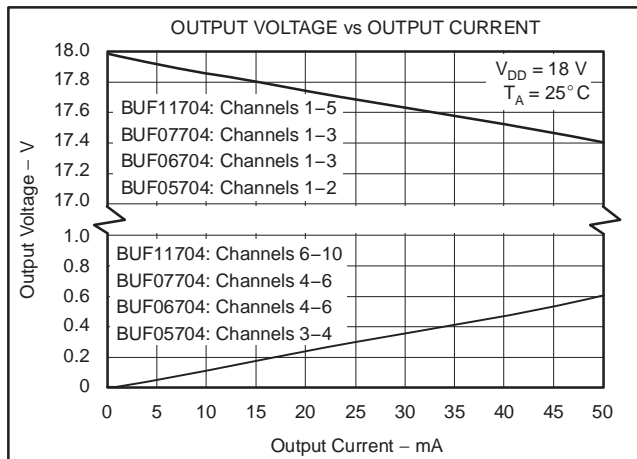

Figure 24. Gamma Buffer Drive Capability

### APPLICATIONS WITH >10 GAMMA CHANNELS

When a greater number of gamma correction channels are required, two or more BUFxx704 devices can be used in parallel, as shown in Figure 25. This capability provides a cost-effective way of creating more reference voltages over the use of quad-channel op amps or buffers. The suggested configuration in Figure 25 simplifies layout. The various different channel versions provide a high degree of flexibility and also minimize total cost and space.

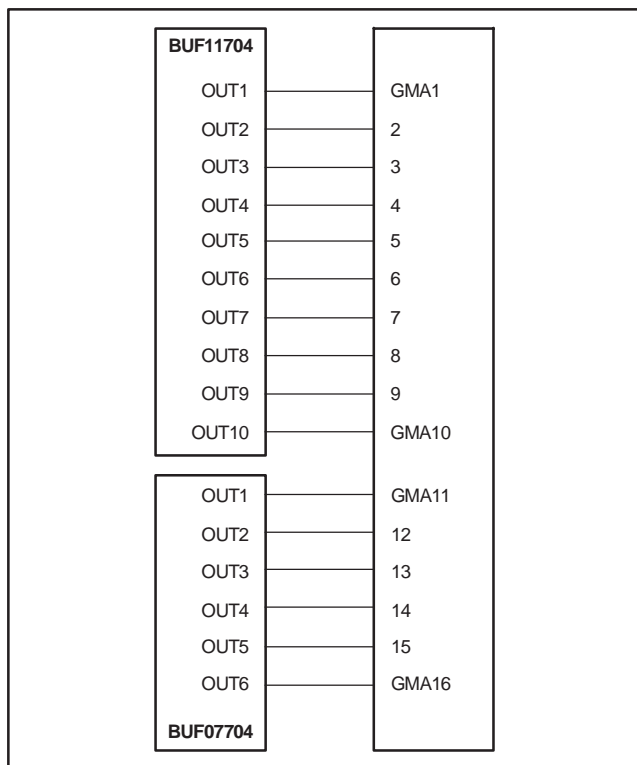

Figure 25. Creating > 10 Gamma Voltage Channels

### MULTIPLE $V_{COM}$ CHANNELS

In some LCD panels, more than one  $V_{COM}$  driver is required for best panel performance. Figure 26 uses three BUF07704s to create a total of 18 gamma-correction and three  $V_{COM}$  channels. This solution saves considerable space and cost over the more conventional approach of using five or six quad-channel buffers or op amps.

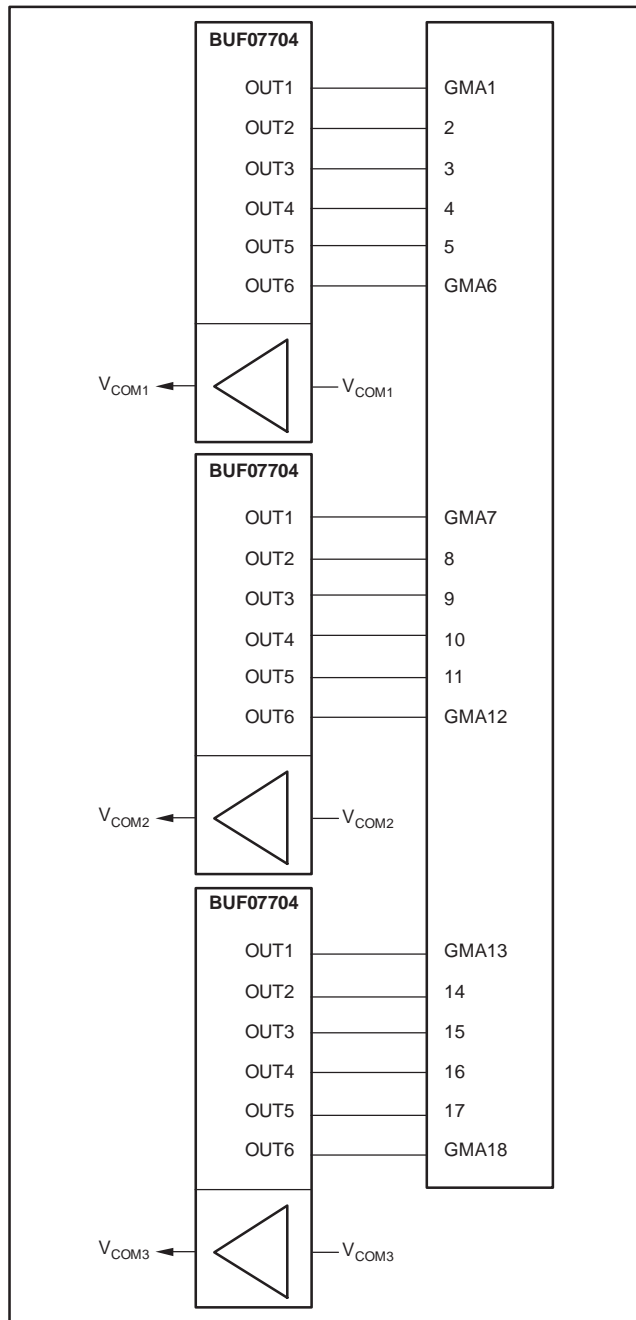

Figure 26. 18-Channel Application with Three Integrated  $V_{COM}$  Channels

**Table 1. How to Combine for > 10 Channels**

	BUF05704	BUF06704	BUF07704	BUF11704
12ch	—	2	—	—
12ch + V <sub>COM</sub>	—	1	1	—
14ch + V <sub>COM</sub>	1	—	—	1
16ch + V <sub>COM</sub>	—	1	—	1
18ch + V <sub>COM</sub>	—	—	—	2
20ch + V <sub>COM</sub>	—	—	—	2

**COMPLETE LCD SOLUTION FROM TI**

In addition to the BUFxx704 line of gamma correction buffers, TI offers a complete set of ICs for the LCD panel market, including source and gate drivers, timing controllers, various power-supply solutions, and audio power solutions. Figure 27 shows the total IC solution from TI.

**AUDIO POWER AMPLIFIER FOR TV SPEAKERS**

The TPA3005D2 is a 6 W (per channel) stereo audio amplifier specifically targeted towards LCD monitors and TVs. It offers highly efficient, filter-free Class-D operation for driving bridge-tied stereo speakers. The TPA3005D2 is designed to drive stereo speakers as low as 8 Ω without an output filter. The high efficiency of the TPA3005D2 eliminates the need for external heatsinks when playing music. The TPA3008D2 is similar to the

TPA3005D2, but is capable of 8 W of output power. Texas Instruments offers a full line of linear and switch-mode audio power amplifiers. For more information, visit www.ti.com. For excellent audio performance, TI recommends the OPA364 (SBOS259) or OPA353 (SBOS103) as headphone drivers.

**INTEGRATED DC/DC CONVERTERS FOR LCD PANELS: TPS65100 and TPS65140**

The TPS65100 and TPS65140 offer a very compact and small power supply solution to provide all three power-supply voltages required by TFT (thin film transistor) LCD displays. Additionally the devices have an integrated V<sub>COM</sub> buffer. The auxiliary linear regulator controller can be used to generate the 3.3 V logic power rail for systems powered by a 5 V supply rail only. The main output can power the LCD source drivers as well as the BUFxx704. An integrated adjustable charge pump doubler/tripler provides the positive LCD gate drive voltage. An externally adjustable negative charge pump provides the negative gate drive voltage. The TPS65100 has an integrated V<sub>COM</sub> buffer to power the LCD backplane. A version of the BUFxx704 without the integrated V<sub>COM</sub> buffer could be used for minimum redundancy and lowest cost. For LCD panels powered by 5 V only, the TPS65100 has a linear regulator controller that uses an external transistor to provide a regulated 3.3 V output for the digital circuits. Contact the local sales office for more information.

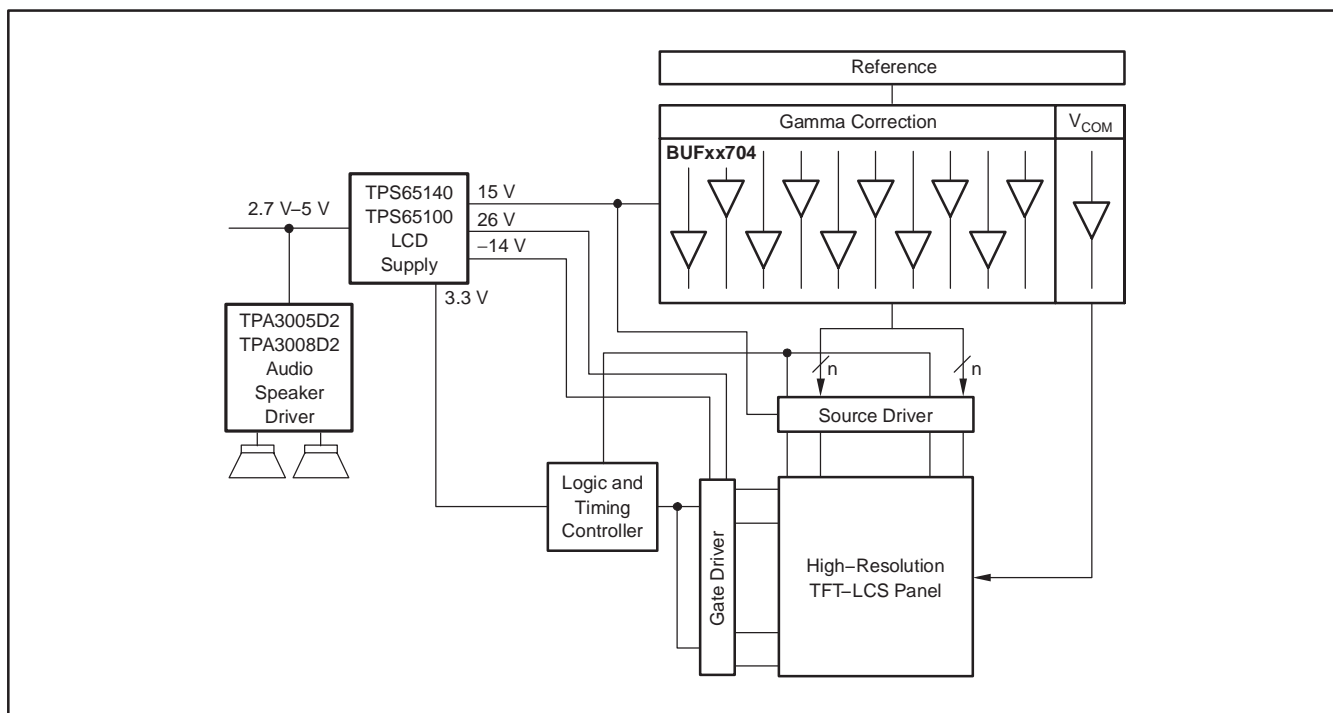

**Figure 27. TI LCD Solution**

## GENERAL PowerPAD DESIGN CONSIDERATIONS

The BUFxx704 is available in the thermally-enhanced PowerPAD family of packages. These packages are constructed using a downset leadframe upon which the die is mounted, as shown in Figure 28(a) and (b). This arrangement results in the lead frame being exposed as a thermal pad on the underside of the package; see Figure 28(c). Due to this thermal pad having direct thermal contact with the die, excellent thermal performance is achieved by providing a good thermal path away from the thermal pad.

The PowerPAD package allows for both assembly and thermal management in one manufacturing operation. During the surface-mount solder operation (when the leads are being soldered), the thermal pad must be soldered to a copper area underneath the package. Through the use of thermal paths within this copper area, heat can be conducted away from the package into either a ground plane or other heat-dissipating device. **Soldering the PowerPAD to the PCB is always required, even with applications that have low power dissipation.** This provides the necessary thermal and mechanical connection between the lead frame die pad and the PCB.

The PowerPAD must be connected to the device's most negative supply voltage.

1. Prepare the PCB with a top-side etch pattern. There should be etching for the leads as well as etch for the thermal pad.
2. Place recommended holes in the area of the thermal pad. Ideal thermal land size and thermal via patterns (2x3 for BUF05704 PWP-14 and BUF06704 PWP-16; 2x4 for BUF07704 PWP-20; and 2x5 for BUF11704 PWP-28) can be seen in the technical brief, *PowerPAD Thermally-Enhanced Package* (SLMA002), available for download at [www.ti.com](http://www.ti.com). These holes should be 13 mils in diameter. Keep

them small, so that solder wicking through the holes is not a problem during reflow.

3. Additional vias may be placed anywhere along the thermal plane outside of the thermal pad area. This helps dissipate the heat generated by the BUFxx704 IC. These additional vias may be larger than the 13-mil diameter vias directly under the thermal pad. They can be larger because they are not in the thermal pad area to be soldered; thus, wicking is not a problem.
4. Connect all holes to the internal ground plane.
5. When connecting these holes to the ground plane, do not use the typical web or spoke via connection methodology. Web connections have a high thermal resistance connection that is useful for slowing the heat transfer during soldering operations. This makes the soldering of vias that have plane connections easier. In this application, however, low thermal resistance is desired for the most efficient heat transfer. Therefore, the holes under the BUFxx704 PowerPAD package should make their connection to the internal ground plane with a complete connection around the entire circumference of the plated-through hole.
6. The top-side solder mask should leave the terminals of the package and the thermal pad area with its six holes (BUF05704 and BUF06704), eight holes (BUF07704) or ten holes (BUF11704) exposed. The bottom-side solder mask should cover the holes of the thermal pad area. This prevents solder from being pulled away from the thermal pad area during the reflow process.
7. Apply solder paste to the exposed thermal pad area and all of the IC terminals.
8. With these preparatory steps in place, the BUFxx704 IC is simply placed in position and run through the solder reflow operation as any standard surface-mount component. This preparation results in a properly installed part.

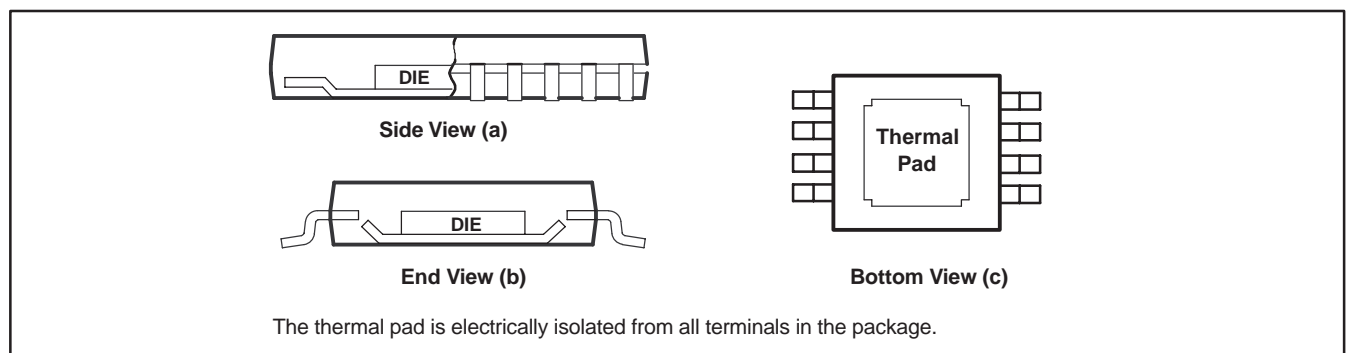

**Figure 28. Views of Thermally-Enhanced DGN Package**

For a given  $\theta_{JA}$ , the maximum power dissipation is shown in Figure 29, and is calculated by the following formula:

$$P_D = \left( \frac{T_{MAX} - T_A}{\theta_{JA}} \right)$$

Where:

- $P_D$  = maximum power dissipation (W)
- $T_{MAX}$  = absolute maximum junction temperature (125°C)
- $T_A$  = free-ambient air temperature (°C)
- $\theta_{JA} = \theta_{JC} + \theta_{CA}$
- $\theta_{JC}$  = thermal coefficient from junction to case (°C/W)
- $\theta_{CA}$  = thermal coefficient from case-to-ambient air (°C/W)

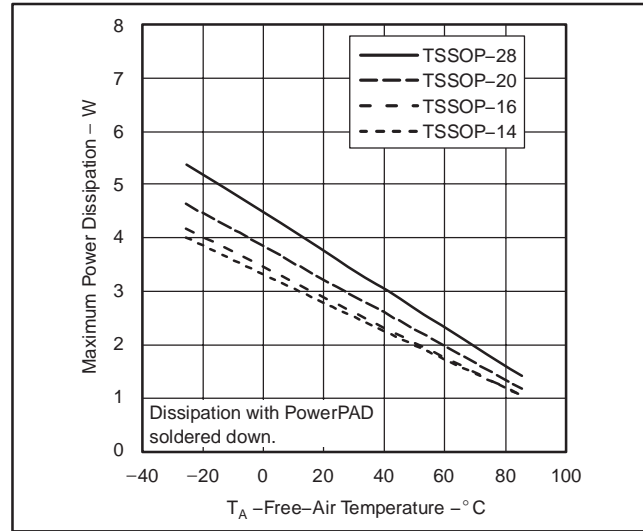

**Figure 29. Maximum Power Dissipation vs Free-Air Temperature**

**THERMAL INFORMATION**

This PowerPAD™ package incorporates an exposed thermal pad that is designed to be attached directly to an external heatsink. When the thermal pad is soldered directly to the printed circuit board (PCB), the PCB can be used as a heatsink. In addition, through the use of thermal vias, the thermal pad can be attached directly to a ground plane or special heatsink structure designed into the PCB. This design optimizes the heat transfer from the integrated circuit (IC).

For additional information on the PowerPAD package and how to take advantage of its heat dissipating abilities, refer to Technical Brief, *PowerPAD Thermally Enhanced Package*, Texas Instruments Literature No. SLMA002 and Application Brief, *PowerPAD Made Easy*, Texas Instruments Literature No. SLMA004. Both documents are available at www.ti.com.

The exposed thermal pad dimensions for this package are shown in the following illustration.

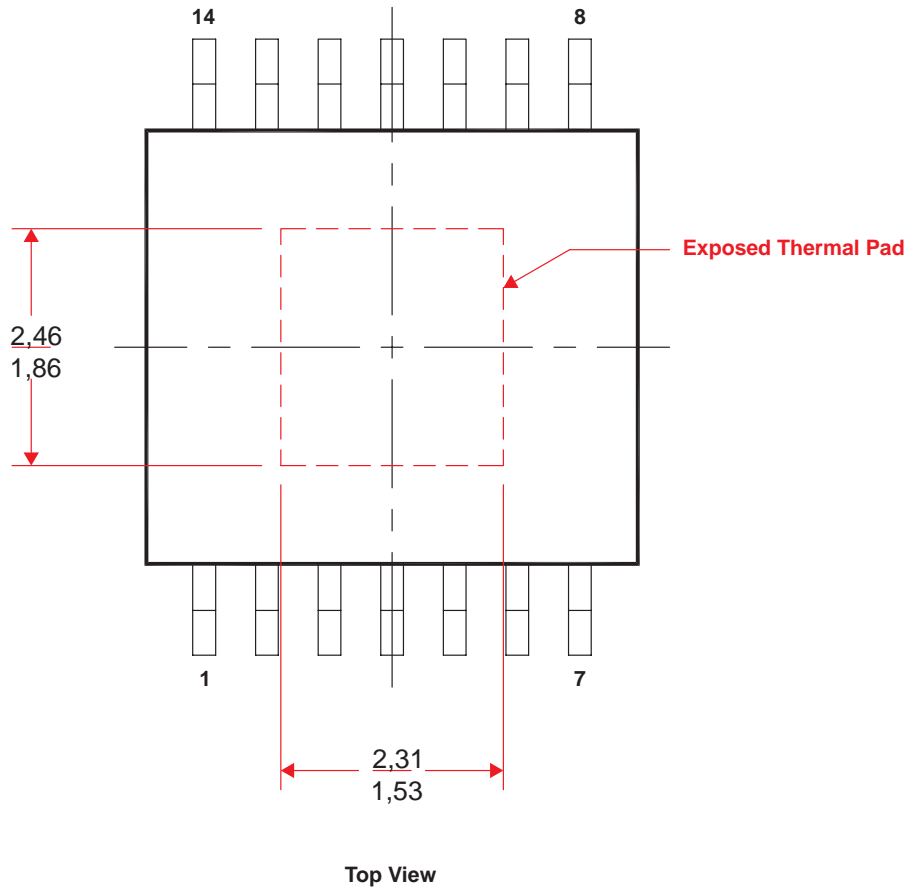

NOTE: All linear dimensions are in millimeters

PPTD023

**Exposed Thermal Pad Dimensions**

**THERMAL INFORMATION**

This PowerPAD™ package incorporates an exposed thermal pad that is designed to be attached directly to an external heatsink. When the thermal pad is soldered directly to the printed circuit board (PCB), the PCB can be used as a heatsink. In addition, through the use of thermal vias, the thermal pad can be attached directly to a ground plane or special heatsink structure designed into the PCB. This design optimizes the heat transfer from the integrated circuit (IC).

For additional information on the PowerPAD package and how to take advantage of its heat dissipating abilities, refer to Technical Brief, *PowerPAD Thermally Enhanced Package*, Texas Instruments Literature No. SLMA002 and Application Brief, *PowerPAD Made Easy*, Texas Instruments Literature No. SLMA004. Both documents are available at www.ti.com.

The exposed thermal pad dimensions for this package are shown in the following illustration.

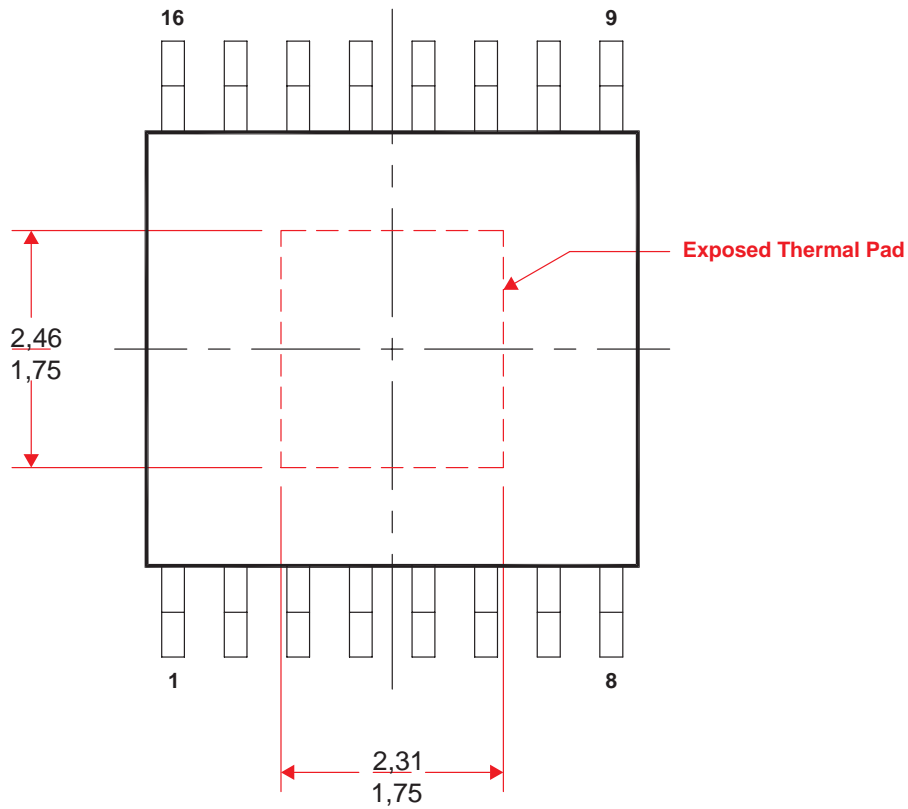

**Top View**

NOTE: All linear dimensions are in millimeters

PPTD024

**Exposed Thermal Pad Dimensions**

**THERMAL INFORMATION**

This PowerPAD™ package incorporates an exposed thermal pad that is designed to be attached directly to an external heatsink. When the thermal pad is soldered directly to the printed circuit board (PCB), the PCB can be used as a heatsink. In addition, through the use of thermal vias, the thermal pad can be attached directly to a ground plane or special heatsink structure designed into the PCB. This design optimizes the heat transfer from the integrated circuit (IC).

For additional information on the PowerPAD package and how to take advantage of its heat dissipating abilities, refer to Technical Brief, *PowerPAD Thermally Enhanced Package*, Texas Instruments Literature No. SLMA002 and Application Brief, *PowerPAD Made Easy*, Texas Instruments Literature No. SLMA004. Both documents are available at www.ti.com.

The exposed thermal pad dimensions for this package are shown in the following illustration.

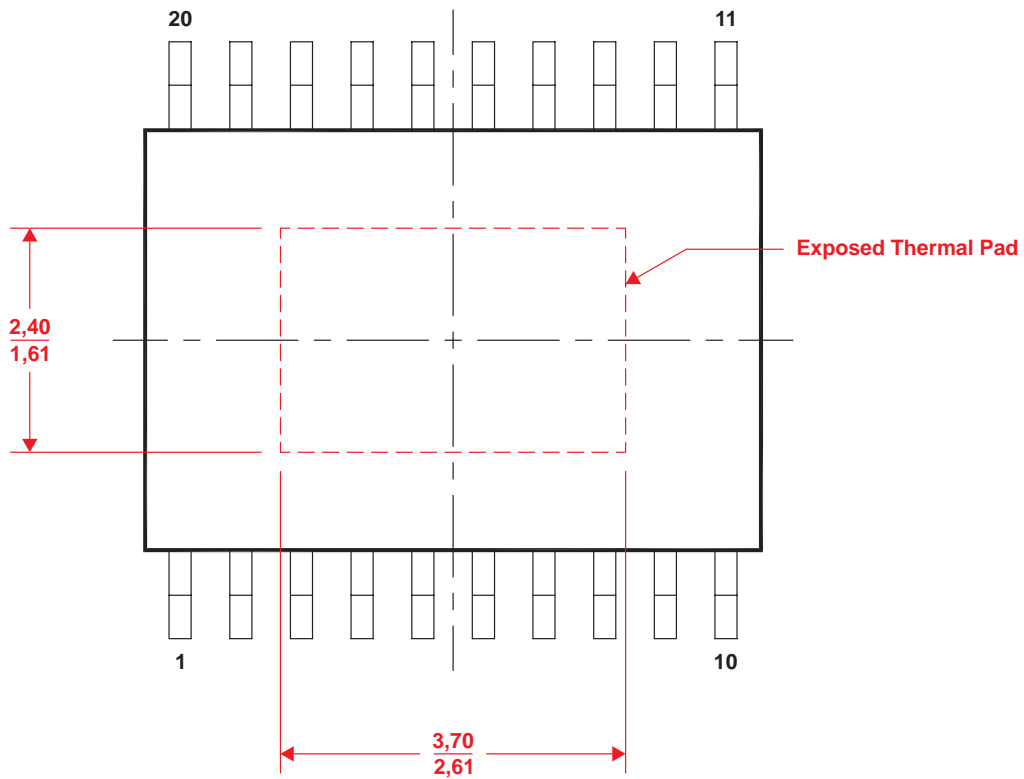

Top View

NOTE: All linear dimensions are in millimeters

PPTD027

**Exposed Thermal Pad Dimensions**

**THERMAL INFORMATION**

This PowerPAD™ package incorporates an exposed thermal pad that is designed to be attached directly to an external heatsink. When the thermal pad is soldered directly to the printed circuit board (PCB), the PCB can be used as a heatsink. In addition, through the use of thermal vias, the thermal pad can be attached directly to a ground plane or special heatsink structure designed into the PCB. This design optimizes the heat transfer from the integrated circuit (IC).

For additional information on the PowerPAD package and how to take advantage of its heat dissipating abilities, refer to Technical Brief, *PowerPAD Thermally Enhanced Package*, Texas Instruments Literature No. SLMA002 and Application Brief, *PowerPAD Made Easy*, Texas Instruments Literature No. SLMA004. Both documents are available at www.ti.com.

The exposed thermal pad dimensions for this package are shown in the following illustration.

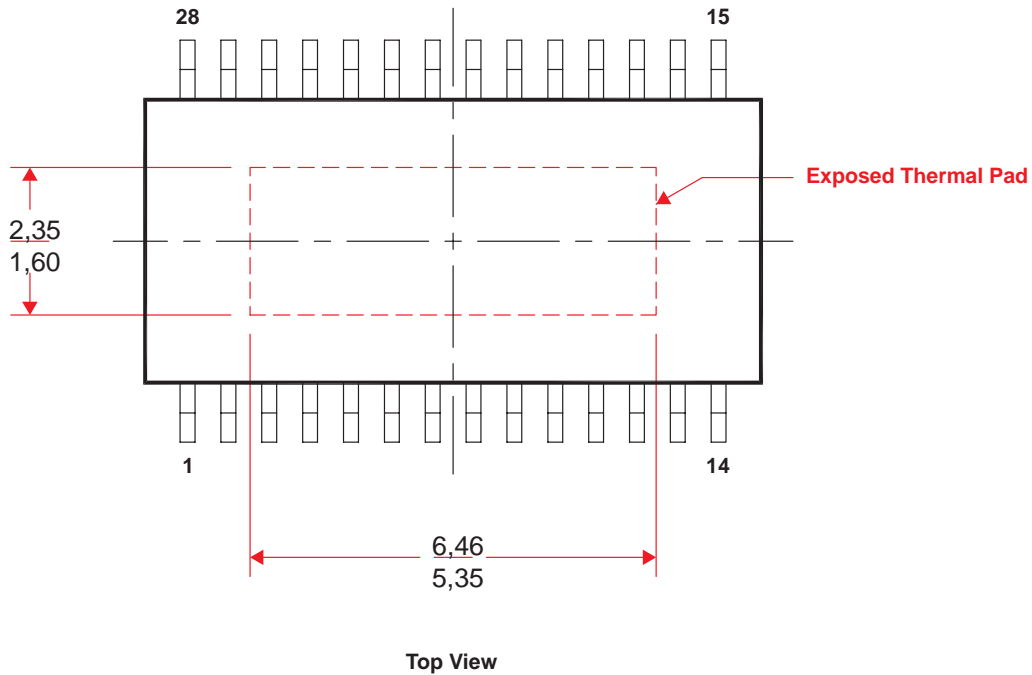

NOTE: All linear dimensions are in millimeters

PPTD032

**Exposed Thermal Pad Dimensions**

**PACKAGING INFORMATION**

Orderable Device	Status <sup>(1)</sup>	Package Type	Package Drawing	Pins	Package Qty	Eco Plan <sup>(2)</sup>	Lead/Ball Finish	MSL Peak Temp <sup>(3)</sup>
BUF05704AIPWP	ACTIVE	HTSSOP	PWP	14	90	Green (RoHS & no Sb/Br)	CU NIPDAU	Level-2-260C-1 YEAR
BUF05704AIPWPR	ACTIVE	HTSSOP	PWP	14	2000	Green (RoHS & no Sb/Br)	CU NIPDAU	Level-2-260C-1 YEAR
BUF06704AIPWP	ACTIVE	HTSSOP	PWP	16	90	Green (RoHS & no Sb/Br)	CU NIPDAU	Level-2-260C-1 YEAR
BUF07704AIPWP	ACTIVE	HTSSOP	PWP	20	70	None	CU NIPDAU	Level-1-220C-UNLIM
BUF07704AIPWPR	ACTIVE	HTSSOP	PWP	20	2000	None	CU NIPDAU	Level-1-220C-UNLIM
BUF11704AIPWP	ACTIVE	HTSSOP	PWP	28	50	None	CU NIPDAU	Level-2-260C-1 YEAR
BUF11704AIPWPR	ACTIVE	HTSSOP	PWP	28	2000	None	CU NIPDAU	Level-2-260C-1 YEAR

<sup>(1)</sup> The marketing status values are defined as follows:

**ACTIVE:** Product device recommended for new designs.

**LIFEBUY:** TI has announced that the device will be discontinued, and a lifetime-buy period is in effect.

**NRND:** Not recommended for new designs. Device is in production to support existing customers, but TI does not recommend using this part in a new design.

**PREVIEW:** Device has been announced but is not in production. Samples may or may not be available.

**OBSOLETE:** TI has discontinued the production of the device.

<sup>(2)</sup> Eco Plan - May not be currently available - please check <http://www.ti.com/productcontent> for the latest availability information and additional product content details.

**None:** Not yet available Lead (Pb-Free).

**Pb-Free (RoHS):** TI's terms "Lead-Free" or "Pb-Free" mean semiconductor products that are compatible with the current RoHS requirements for all 6 substances, including the requirement that lead not exceed 0.1% by weight in homogeneous materials. Where designed to be soldered at high temperatures, TI Pb-Free products are suitable for use in specified lead-free processes.

**Green (RoHS & no Sb/Br):** TI defines "Green" to mean "Pb-Free" and in addition, uses package materials that do not contain halogens, including bromine (Br) or antimony (Sb) above 0.1% of total product weight.

<sup>(3)</sup> MSL, Peak Temp. -- The Moisture Sensitivity Level rating according to the JEDEC industry standard classifications, and peak solder temperature.

**Important Information and Disclaimer:** The information provided on this page represents TI's knowledge and belief as of the date that it is provided. TI bases its knowledge and belief on information provided by third parties, and makes no representation or warranty as to the accuracy of such information. Efforts are underway to better integrate information from third parties. TI has taken and continues to take reasonable steps to provide representative and accurate information but may not have conducted destructive testing or chemical analysis on incoming materials and chemicals. TI and TI suppliers consider certain information to be proprietary, and thus CAS numbers and other limited information may not be available for release.

In no event shall TI's liability arising out of such information exceed the total purchase price of the TI part(s) at issue in this document sold by TI to Customer on an annual basis.

PWP (R-PDSO-G\*\*)

PowerPAD™ PLASTIC SMALL-OUTLINE PACKAGE

20 PIN SHOWN

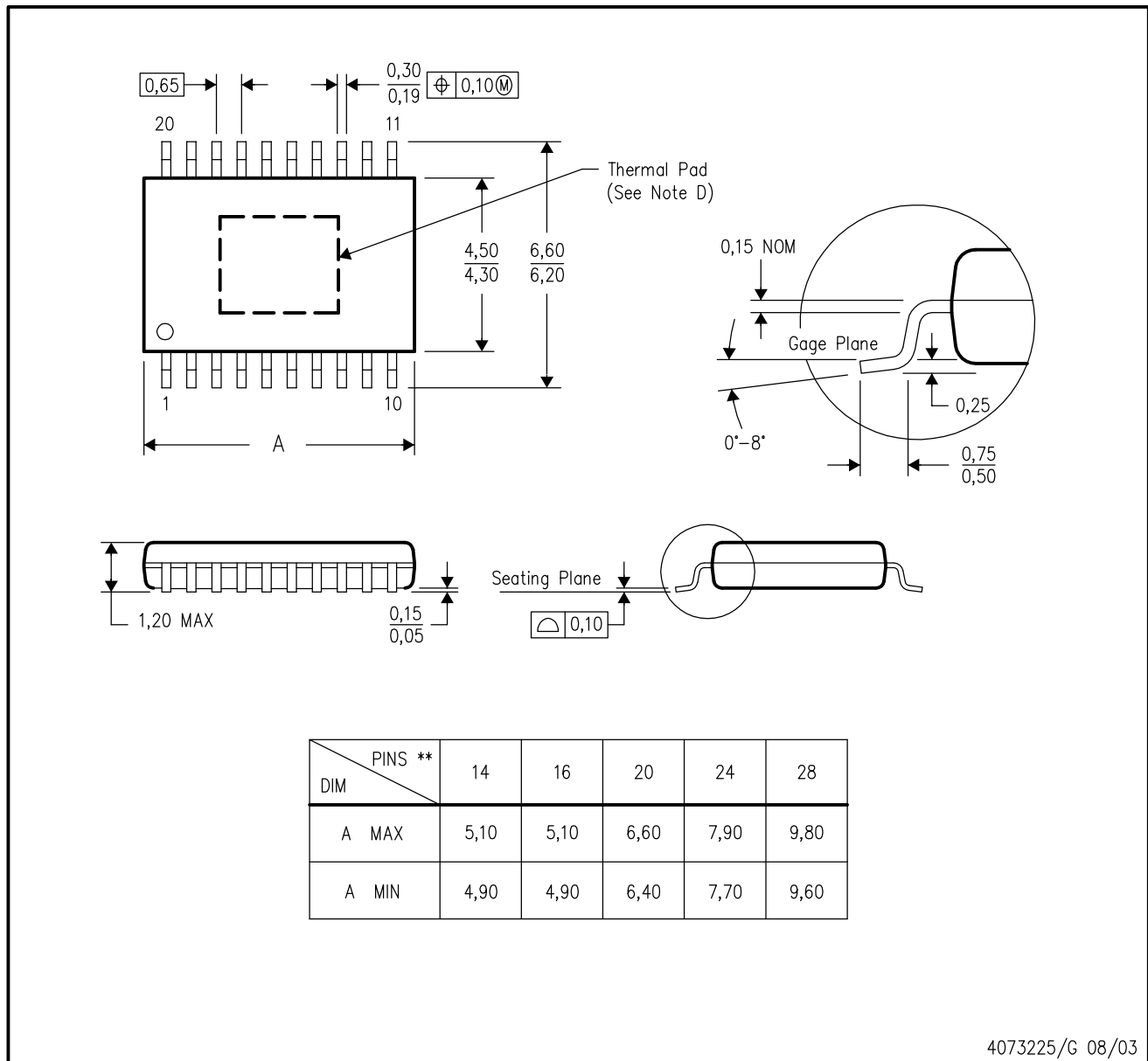

4073225/G 08/03

- NOTES:
- A. All linear dimensions are in millimeters.
  - B. This drawing is subject to change without notice.
  - C. Body dimensions do not include mold flash or protrusions.
  - D. This package is designed to be soldered to a thermal pad on the board. Refer to Technical Brief, PowerPad Thermally Enhanced Package, Texas Instruments Literature No. SLMA002 for information regarding recommended board layout. This document is available at [www.ti.com](http://www.ti.com) <<http://www.ti.com>>.
  - E. Falls within JEDEC MO-153

PowerPAD is a trademark of Texas Instruments.

## IMPORTANT NOTICE

Texas Instruments Incorporated and its subsidiaries (TI) reserve the right to make corrections, modifications, enhancements, improvements, and other changes to its products and services at any time and to discontinue any product or service without notice. Customers should obtain the latest relevant information before placing orders and should verify that such information is current and complete. All products are sold subject to TI's terms and conditions of sale supplied at the time of order acknowledgment.

TI warrants performance of its hardware products to the specifications applicable at the time of sale in accordance with TI's standard warranty. Testing and other quality control techniques are used to the extent TI deems necessary to support this warranty. Except where mandated by government requirements, testing of all parameters of each product is not necessarily performed.

TI assumes no liability for applications assistance or customer product design. Customers are responsible for their products and applications using TI components. To minimize the risks associated with customer products and applications, customers should provide adequate design and operating safeguards.

TI does not warrant or represent that any license, either express or implied, is granted under any TI patent right, copyright, mask work right, or other TI intellectual property right relating to any combination, machine, or process in which TI products or services are used. Information published by TI regarding third-party products or services does not constitute a license from TI to use such products or services or a warranty or endorsement thereof. Use of such information may require a license from a third party under the patents or other intellectual property of the third party, or a license from TI under the patents or other intellectual property of TI.

Reproduction of information in TI data books or data sheets is permissible only if reproduction is without alteration and is accompanied by all associated warranties, conditions, limitations, and notices. Reproduction of this information with alteration is an unfair and deceptive business practice. TI is not responsible or liable for such altered documentation.

Resale of TI products or services with statements different from or beyond the parameters stated by TI for that product or service voids all express and any implied warranties for the associated TI product or service and is an unfair and deceptive business practice. TI is not responsible or liable for any such statements.

Following are URLs where you can obtain information on other Texas Instruments products and application solutions:

<b>Products</b>		<b>Applications</b>	
Amplifiers	<a href="http://amplifier.ti.com">amplifier.ti.com</a>	Audio	<a href="http://www.ti.com/audio">www.ti.com/audio</a>
Data Converters	<a href="http://dataconverter.ti.com">dataconverter.ti.com</a>	Automotive	<a href="http://www.ti.com/automotive">www.ti.com/automotive</a>
DSP	<a href="http://dsp.ti.com">dsp.ti.com</a>	Broadband	<a href="http://www.ti.com/broadband">www.ti.com/broadband</a>
Interface	<a href="http://interface.ti.com">interface.ti.com</a>	Digital Control	<a href="http://www.ti.com/digitalcontrol">www.ti.com/digitalcontrol</a>
Logic	<a href="http://logic.ti.com">logic.ti.com</a>	Military	<a href="http://www.ti.com/military">www.ti.com/military</a>
Power Mgmt	<a href="http://power.ti.com">power.ti.com</a>	Optical Networking	<a href="http://www.ti.com/opticalnetwork">www.ti.com/opticalnetwork</a>
Microcontrollers	<a href="http://microcontroller.ti.com">microcontroller.ti.com</a>	Security	<a href="http://www.ti.com/security">www.ti.com/security</a>
		Telephony	<a href="http://www.ti.com/telephony">www.ti.com/telephony</a>
		Video & Imaging	<a href="http://www.ti.com/video">www.ti.com/video</a>
		Wireless	<a href="http://www.ti.com/wireless">www.ti.com/wireless</a>

Mailing Address: Texas Instruments  
Post Office Box 655303 Dallas, Texas 75265