

CD4051B-Q1, CD4052B-Q1, CD4053B-Q1 CMOS ANALOG MULTIPLEXERS/DEMULPLEXERS WITH LOGIC-LEVEL CONVERSION

SCHS354 – AUGUST 2004

Features

- Qualification in Accordance With AEC-Q100†
- Qualified for Automotive Applications
- Customer-Specific Configuration Control Can Be Supported Along With Major-Change Approval
- Wide Range of Digital and Analog Signal Levels
 - Digital: 3 V to 20 V
 - Analog: $\leq 20 V_{P-P}$
- Low ON Resistance, 125 Ω (Typ) Over 15 V_{P-P} Signal Input Range for $V_{DD} - V_{EE} = 18 V$
- High OFF Resistance, Channel Leakage of $\pm 100 pA$ (Typ) at $V_{DD} - V_{EE} = 18 V$
- Logic-Level Conversion for Digital Addressing Signals of 3 V to 20 V ($V_{DD} - V_{SS} = 3 V$ to 20 V) to Switch Analog Signals to 20 V_{P-P} ($V_{DD} - V_{EE} = 20 V$)

† Contact factory for details. Q100 qualification data available on request.

- Matched Switching Characteristics, $r_{on} = 5 \Omega$ (Typ) for $V_{DD} - V_{EE} = 15 V$
- Very Low Quiescent Power Dissipation Under All Digital-Control Input and Supply Conditions, 0.2 μW (Typ) at $V_{DD} - V_{SS} = V_{DD} - V_{EE} = 10 V$
- Binary Address Decoding on Chip
- 5-V, 10-V, and 15-V Parametric Ratings
- 100% Tested for Quiescent Current at 20 V
- Maximum Input Current of 1 μA at 18 V Over Full Package Temperature Range, 100 nA at 18 V and 25°C
- Break-Before-Make Switching Eliminates Channel Overlap

Applications

- Analog and Digital Multiplexing and Demultiplexing
- Analog-to-Digital (A/D) and Digital-to-Analog (D/A) Conversion
- Signal Gating

description/ordering information

The CD4051B, CD4052B, and CD4053B analog multiplexers are digitally-controlled analog switches that have low ON impedance and very low OFF leakage current. Control of analog signals up to 20 V_{P-P} can be achieved by digital signal amplitudes of 4.5 V to 20 V (If $V_{DD} - V_{SS} = 3 V$, a $V_{DD} - V_{EE}$ of up to 13 V can be controlled; for $V_{DD} - V_{EE}$ level differences above 13 V, a $V_{DD} - V_{SS}$ of at least 4.5 V is required). For example, if $V_{DD} = 4.5 V$, $V_{SS} = 0 V$, and $V_{EE} = -13.5 V$, analog signals from $-13.5 V$ to 4.5 V can be controlled by digital inputs of 0 V to 5 V. These multiplexer circuits dissipate extremely low quiescent power over the full $V_{DD} - V_{SS}$ and $V_{DD} - V_{EE}$ supply-voltage ranges, independent of the logic state of the control signals. When a logic high (H) is present at the inhibit (INH) input, all channels are off.

ORDERING INFORMATION

TA	PACKAGE‡		ORDERABLE PART NUMBER	TOP-SIDE MARKING
-40°C to 125°C	SOIC – M	Reel of 2500	CD4051BQM96Q1	CD4051Q
	TSSOP – PW	Reel of 2000	CD4051BQPWRQ1	CM051BQ
	SOIC – M	Reel of 2500	CD4052BQM96Q1§	CD4052Q
	TSSOP – PW	Reel of 2000	CD4052BQPWRQ1§	CD4052Q
	SOIC – M	Reel of 2500	CD4053BQM96Q1	CD4053Q
	TSSOP – PW	Reel of 2000	CD4053BQPWRQ1§	CD4053Q

‡ Package drawings, standard packing quantities, thermal data, symbolization, and PCB design guidelines are available at www.ti.com/sc/package.

§ Product Preview



Please be aware that an important notice concerning availability, standard warranty, and use in critical applications of Texas Instruments semiconductor products and disclaimers thereto appears at the end of this data sheet.

UNLESS OTHERWISE NOTED this document contains PRODUCTION DATA information current as of publication date. Products conform to specifications per the terms of Texas Instruments standard warranty. Production processing does not necessarily include testing of all parameters.



POST OFFICE BOX 655303 • DALLAS, TEXAS 75265

Copyright © 2004, Texas Instruments Incorporated

CD4051B-Q1, CD4052B-Q1, CD4053B-Q1 CMOS ANALOG MULTIPLEXERS/DEMULTIPLEXERS WITH LOGIC-LEVEL CONVERSION

SCHS354 – AUGUST 2004

description/ordering information (continued)

The CD4051B is a single eight-channel multiplexer that has three binary control inputs (A, B, and C) and an inhibit input. The three binary signals select one of eight channels to be turned on and connect one of the eight inputs to the output.

The CD4052B is a differential four-channel multiplexer that has two binary control inputs (A and B) and an inhibit input. The two binary input signals select one of four pairs of channels to be turned on and connect the analog inputs to the outputs.

The CD4053B is a triple two-channel multiplexer with three separate digital control inputs (A, B, and C) and an inhibit input. Each control input selects one of a pair of channels, which are connected in a single-pole, double-throw configuration.

When these devices are used as demultiplexers, the CHANNEL IN/OUT terminals are the outputs, and the common (COM OUT/IN) terminals are the inputs.

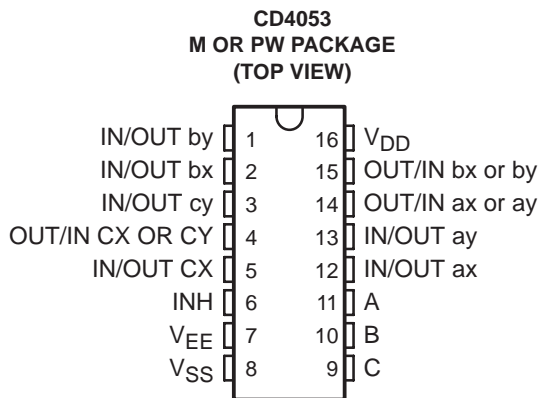
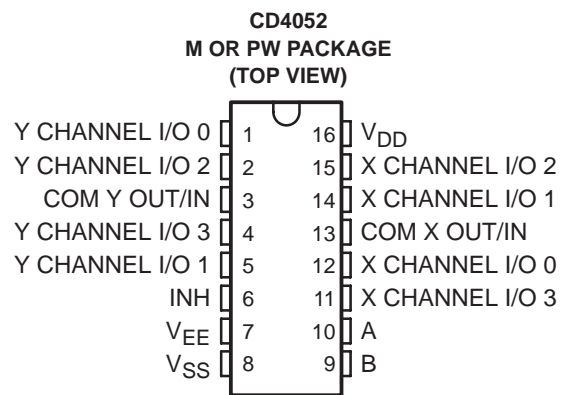
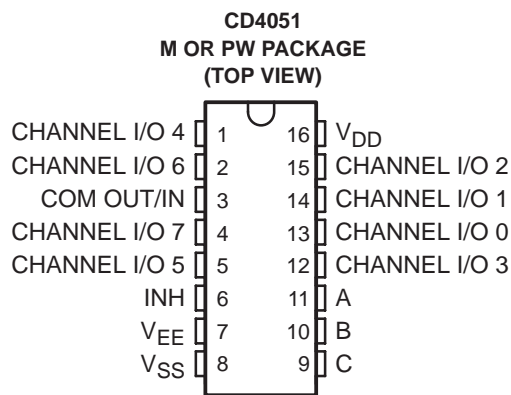

CD4051B-Q1, CD4052B-Q1, CD4053B-Q1
CMOS ANALOG MULTIPLEXERS/DEMULTIPLEXERS
WITH LOGIC-LEVEL CONVERSION

SCHS354 – AUGUST 2004

Function Tables

CD4051

INPUTS				ON CHANNEL
INH	C	B	A	
L	L	L	L	0
L	L	L	H	1
L	L	H	L	2
L	L	H	H	3
L	H	L	L	4
L	H	L	H	5
L	H	H	L	6
L	H	H	H	7
H	X	X	X	None

X = don't care

CD4052

INPUTS			ON CHANNEL
INH	B	A	
L	L	L	0x, 0y
L	L	H	1x, 2y
L	H	L	2x, 2y
L	H	H	3x, 3y
H	X	X	None

X = don't care

CD4053

INPUTS		ON CHANNEL
INH	A OR B OR C	
L	L	ax or bx or cx
L	H	ay or by or cy
H	X	None

X = don't care

CD4051B-Q1, CD4052B-Q1, CD4053B-Q1 CMOS ANALOG MULTIPLEXERS/DEMULTIPLEXERS WITH LOGIC-LEVEL CONVERSION

SCHS354 – AUGUST 2004

logic diagram (positive logic)

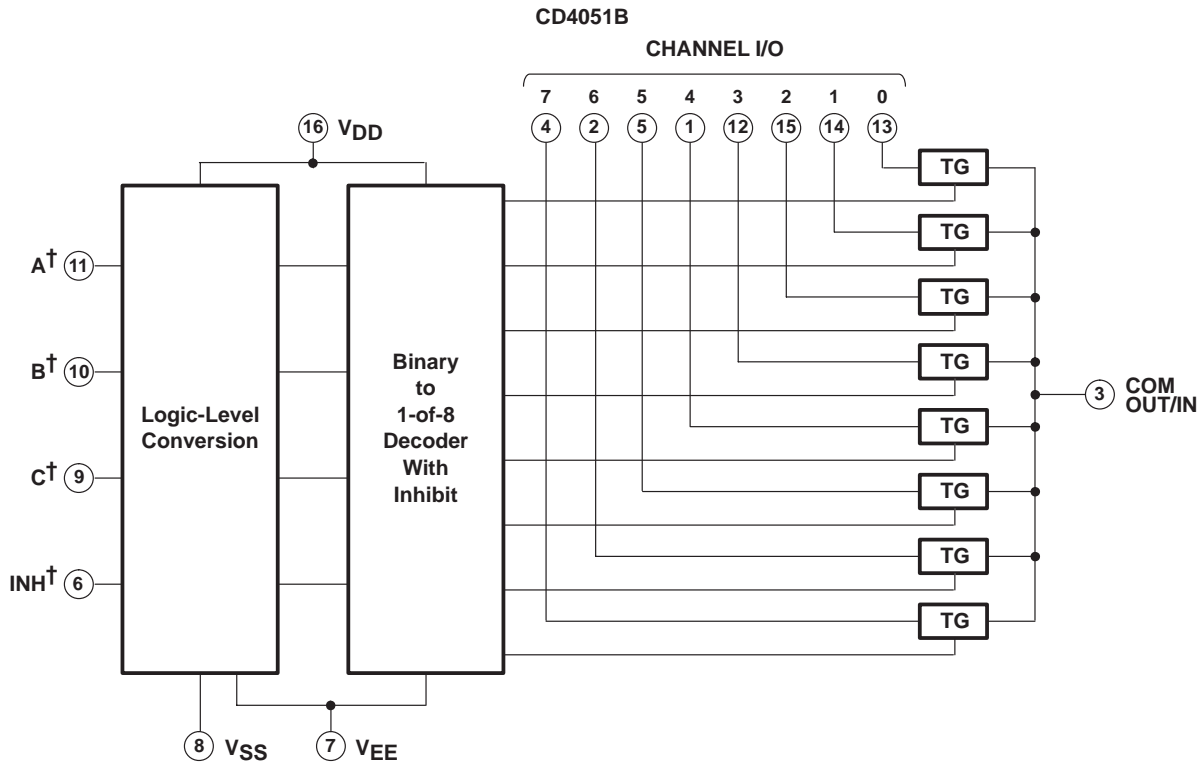

† All inputs are protected by CMOS protection network.

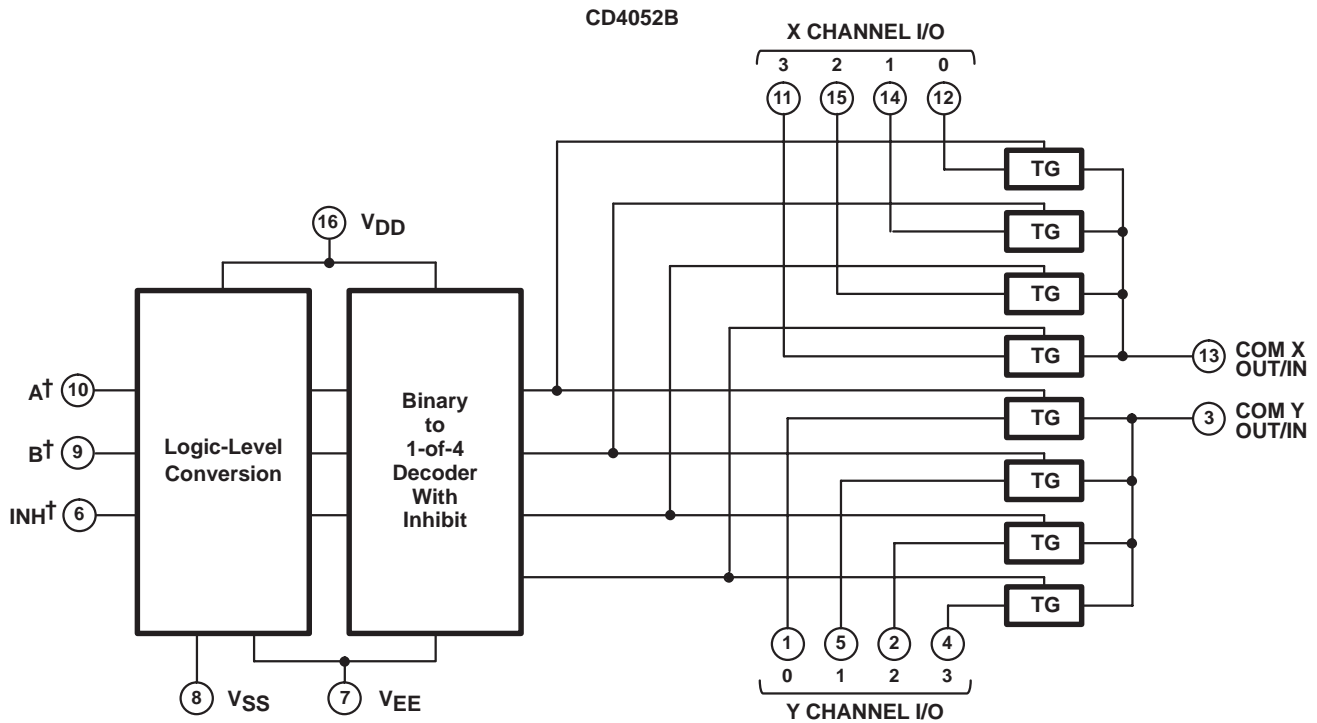

† All inputs are protected by CMOS protection network.



POST OFFICE BOX 655303 • DALLAS, TEXAS 75265

CD4051B-Q1, CD4052B-Q1, CD4053B-Q1 CMOS ANALOG MULTIPLEXERS/DEMULTIPLEXERS WITH LOGIC-LEVEL CONVERSION

SCHS354 – AUGUST 2004

logic diagrams (positive logic) (continued)

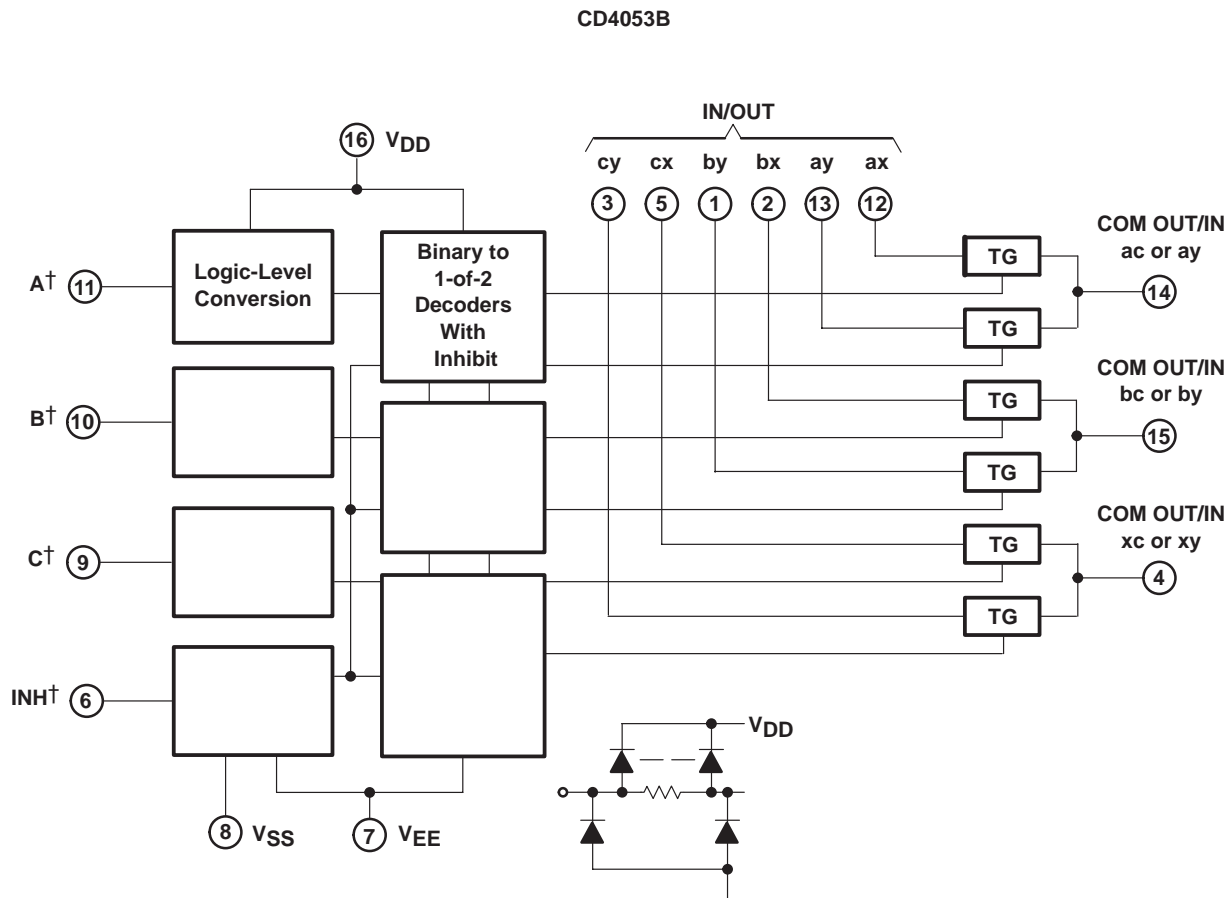

† All inputs are protected by standard CMOS protection network.

absolute maximum ratings over operating free-air temperature (unless otherwise noted)‡

Supply voltage range, V+ to V- (voltages referenced to V _{SS} terminal)	-0.5 to 20 V
DC input voltage range	-0.5 V to V _{DD} + 0.5 V
DC input current, any one input	±10 mA
Package thermal impedance, θ_{JA} (see Note 1): M package	73°C/W
PW package	108°C/W
Maximum junction temperature, T _J	150°C
Lead temperature (during soldering):	
At distance 1/16 ± 1/32 inch (1,59 ± 0,79 mm) from case for 10 s max	265°C
Storage temperature range, T _{Stg}	-65°C to 150°C

‡ Stresses beyond those listed under "absolute maximum ratings" may cause permanent damage to the device. These are stress ratings only, and functional operation of the device at these or any other conditions beyond those indicated under "recommended operating conditions" is not implied. Exposure to absolute-maximum-rated conditions for extended periods may affect device reliability.

NOTE 1: The package thermal impedance is calculated in accordance with JESD 51-7.

CD4051B-Q1, CD4052B-Q1, CD4053B-Q1 CMOS ANALOG MULTIPLEXERS/DEMULTIPLEXERS WITH LOGIC-LEVEL CONVERSION

SCHS354 – AUGUST 2004

recommended operating conditions

		MIN	MAX	UNIT
V_{DD}	Supply voltage	5	20	V
T_A	Operating free-air temperature	-40	125	°C

electrical characteristics, $V_{SUPPLY} = \pm 5$ V, $A_V = 1$ V, $R_L = 100 \Omega$, unless otherwise noted (see Note 2)

PARAMETER	TEST CONDITIONS	V_{DD} (V)	LIMITS AT INDICATED TEMPERATURES				UNIT
			-40°C	125°C	25°C		
					MIN	TYP	
I_{DD} Quiescent device current		5	5	150	0.04	5	μ A
		10	10	300	0.04	10	
		15	20	600	0.04	20	
		20	100	3000	0.08	100	
Signal Input (V_{IS}) and Output (V_{OS})							
r_{on} Drain-to-source ON-state resistance	$V_{EE} = 0$ V, $V_{SS} = 0$ V, $V_{IS} = 0$ to V_{DD}	5	850	1300	470	1050	Ω
		10	330	550	180	400	
		15	210	320	125	240	
Δr_{on} ON-state resistance difference between any two switches	$V_{EE} = 0$ V, $V_{SS} = 0$ V	5			15		Ω
		10			10		
		15			5		
Input/output leakage current (switch off)	Any channel OFF (MAX) or all channels OFF (COM OUT/IN) (Max), $V_{EE} = 0$ V, $V_{SS} = 0$ V, See Note 3	18	± 0.1	± 1	$\pm 10^{-5}$	± 0.1	μ A
C_{is} Input capacitance	$V_{EE} = -5$ V, $V_{SS} = -5$ V	5			5		pF
C_{os} Output capacitance	$V_{EE} = -5$ V, $V_{SS} = -5$ V	CD4051			30		pF
		CD4052	5			18	
		CD4053				9	
C_{ios} Feedthrough capacitance	$V_{EE} = -5$ V, $V_{SS} = -5$ V	5			0.2		pF
t_{pd} Propagation delay (signal input to output)	$V_{IS(p-p)} = V_{DD}$, $R_L = 200$ k Ω , $C_L = 50$ pF, $t_r, t_f = 20$ ns	5			30	60	ns
		10			15	30	
		15			10	20	

NOTES: 2. Peak-to-peak voltage symmetrical about $\frac{V_{DD} - V_{EE}}{2}$

3. Determined by minimum feasible leakage measurement for automatic testing



CD4051B-Q1, CD4052B-Q1, CD4053B-Q1
CMOS ANALOG MULTIPLEXERS/DEMULTIPLEXERS
WITH LOGIC-LEVEL CONVERSION

SCHS354 – AUGUST 2004

electrical characteristics, $V_{SUPPLY} = \pm 5\text{ V}$, $A_V = 1\text{ V}$, $R_L = 100\ \Omega$, unless otherwise noted
(see Note 2) (continued)

PARAMETER	TEST CONDITIONS	V_{EE} (V)	V_{DD} (V)	LIMITS AT INDICATED TEMPERATURES					UNIT
				-40°C	125°C	25°C			
						MIN	TYP	MAX	
Control (Address or Inhibit), V_C									
V_{IL} Input low voltage	$V_{IL} = V_{DD}$ through $1\text{ k}\Omega$, $V_{IH} = V_{DD}$ through $1\text{ k}\Omega$, $R_L = 1\text{ k}\Omega$ to V_{SS} , $I_{IS} < 2\ \mu\text{A}$ on all OFF channels	V_{SS}	5	1.5	1.5	1.5		V	
		V_{SS}	10	3	3	3			
		V_{SS}	15	4	4	4			
V_{IH} Input high voltage	$V_{IL} = V_{DD}$ through $1\text{ k}\Omega$, $V_{IH} = V_{DD}$ through $1\text{ k}\Omega$, $R_L = 1\text{ k}\Omega$ to V_{SS} , $I_{IS} < 2\ \mu\text{A}$ on all OFF channels	V_{SS}	5	3.5	3.5	3.5		V	
		V_{SS}	10	7	7	7			
		V_{SS}	15	11	11	11			
I_{IN} Input current	$V_{IN} = 0\text{ V}, 18\text{ V}$		18	± 0.1	± 1	$\pm 10^{-5}$	± 0.1	μA	
t_{pd1} Address-to-signal OUT (channels ON or OFF) propagation delay	$t_r, t_f = 20\text{ ns}$, $C_L = 50\text{ pF}$, $R_L = 10\text{ k}\Omega$, $V_{SS} = 0\text{ V}$, See Figure 10, Figure 11, and Figure 14	0	5			450	720	ns	
		0	10			160	320		
		0	15			120	240		
		-5	5			225	450		
t_{pd2} Inhibit-to-signal OUT (channel turning ON) propagation delay	$t_r, t_f = 20\text{ ns}$, $C_L = 50\text{ pF}$, $R_L = 1\text{ k}\Omega$, $V_{SS} = 0\text{ V}$, See Figure 11	0	5			400	720	ns	
		0	10			160	320		
		0	15			120	240		
		-10	5			200	400		
t_{pd3} Inhibit-to-signal OUT (channel turning OFF) propagation delay	$t_r, t_f = 20\text{ ns}$, $C_L = 50\text{ pF}$, $R_L = 10\text{ k}\Omega$, $V_{SS} = 0\text{ V}$, See Figure 15	0	5			200	450	ns	
		0	10			90	210		
		0	15			70	160		
		-10	5			130	300		
C_{IN} Input capacitance, any address or inhibit input						5	7.5	pF	

NOTES: 2: Peak-to-peak voltage symmetrical about $\frac{V_{DD} - V_{EE}}{2}$

3: Determined by minimum feasible leakage measurement for automatic testing

CD4051B-Q1, CD4052B-Q1, CD4053B-Q1 CMOS ANALOG MULTIPLEXERS/DEMULTIPLEXERS WITH LOGIC-LEVEL CONVERSION

SCHS354 – AUGUST 2004

electrical specifications

PARAMETER	TEST CONDITIONS		V _{IS} (V)	V _{DD} (V)	LIMITS AT INDICATED TEMPERATURES			UNIT
					25°C			
					MIN	TYP	MAX	
-3-dB cutoff frequency, channel ON (sine-wave input)	R _L = 1 kΩ, V _{OS} at COM OUT/IN, See Note 2, V _{OS} at COM OUT/IN	CD4053	5	10	30			MHz
		CD4052	5	10	25			
		CD4051	5	10	20			
	V _{EE} = V _{SS} , 20log V _{OS} /V _{IS} = -3 dB, V _{OS} at any channel				60			
THD Total harmonic distortion	R _L = 10 kΩ, See Note 2			2	5	0.3		%
				3	10	0.2		
				5	15	0.12		
	V _{EE} = V _{SS} , f _{IS} = 1-kHz sine wave				0.12			
-40-dB feedthrough frequency (all channels OFF)	R _L = 1 kΩ, V _{OS} at COM OUT/IN, See Note 2	CD4053	5	10	8			MHz
		CD4052	5	10	10			
		CD4051	5	10	12			
	V _{EE} = V _{SS} , 20log V _{OS} /V _{IS} = -40 dB, V _{OS} at any channel				8			
-40-dB signal crosstalk frequency	R _L = 1 kΩ, between any two channels, See Note 2			5	10	3		MHz
	V _{EE} = V _{SS} , 20log V _{OS} /V _{IS} = -40 dB, Between sections, Measured on common	CD4052				6		
						10		
	V _{EE} = V _{SS} , 20log V _{OS} /V _{IS} = -40 dB, Between any two sections, In pin 2, Out pin 14	CD4053				2.5		
						6		
V _{EE} = V _{SS} , 20log V _{OS} /V _{IS} = -40 dB, Between any two sections, In pin 15, Out pin 14								
Address or inhibit to signal crosstalk	R _L = 10 kΩ, See Note 4				10	65		mVPEAK
	V _{EE} = 0 V, V _{SS} = 0 V, t _r , t _f = 20 ns, V _{CC} = V _{DD} - V _{SS} (square wave)					65		

NOTES: 2. Peak-to-peak voltage symmetrical about $\frac{V_{DD} - V_{EE}}{2}$

4. Both ends of channel



TYPICAL CHARACTERISTICS

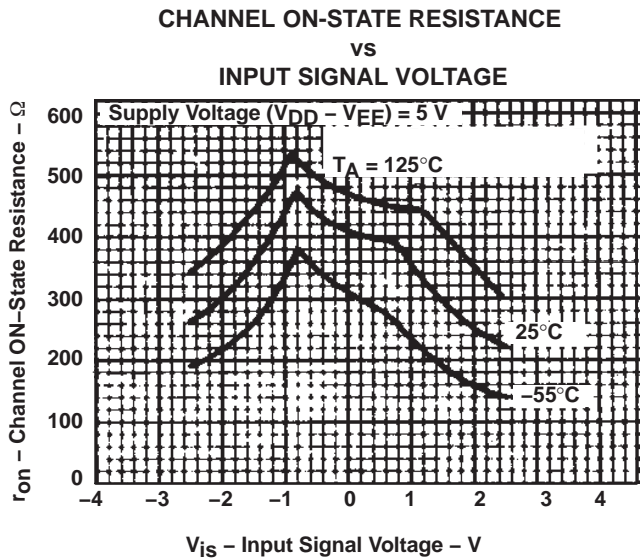

92CS-27326RI

Figure 1

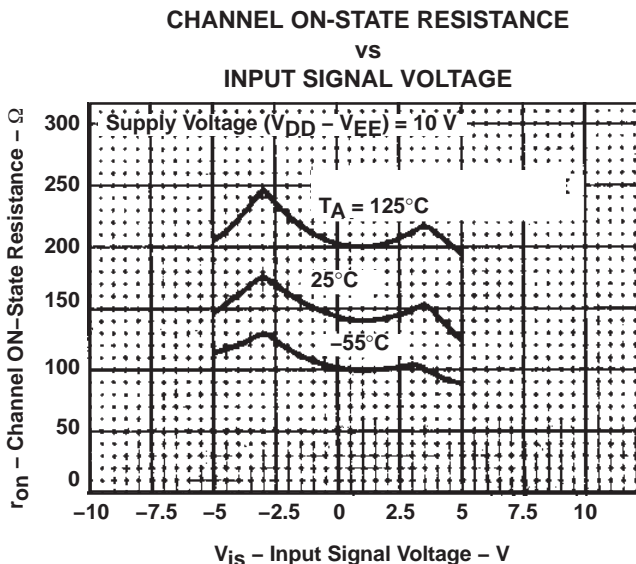

92CS-27327RI

Figure 2

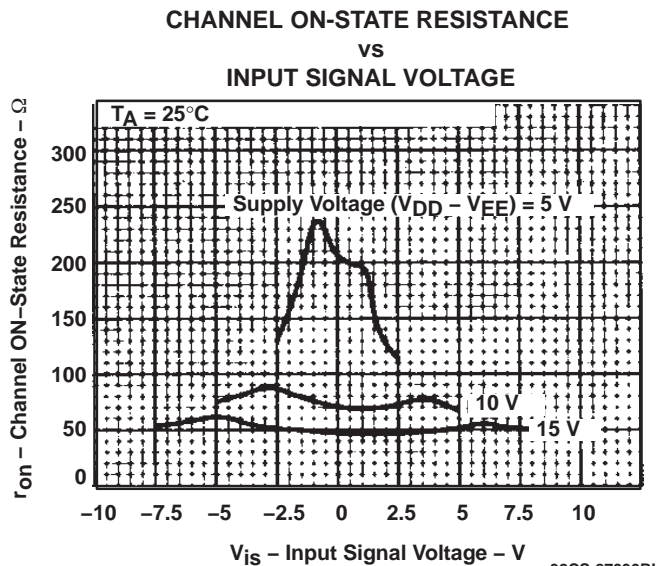

92CS-27330RI

Figure 3

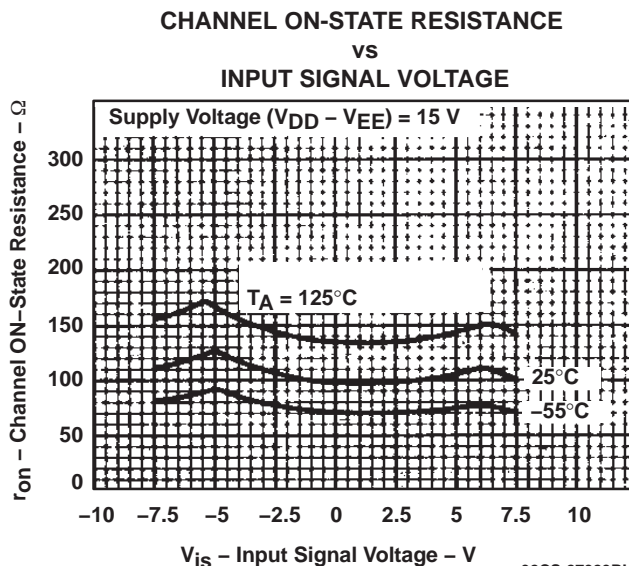

92CS-27329RI

Figure 4

CD4051B-Q1, CD4052B-Q1, CD4053B-Q1 CMOS ANALOG MULTIPLEXERS/DEMULTIPLEXERS WITH LOGIC-LEVEL CONVERSION

SCHS354 – AUGUST 2004

TYPICAL CHARACTERISTICS

ON CHARACTERISTICS FOR
1-OF-8 CHANNELS (CD4051B)

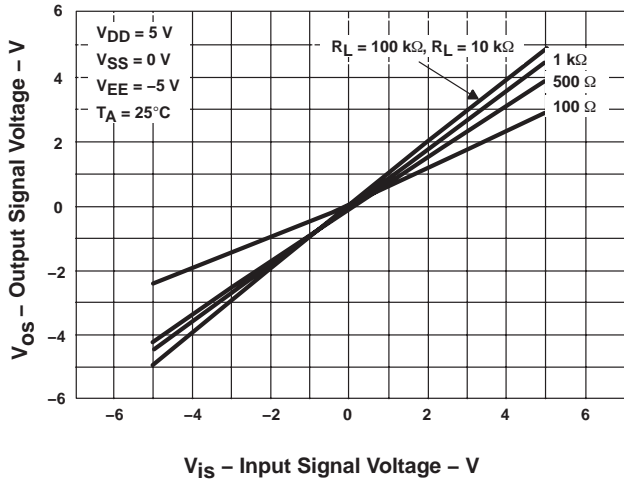

Figure 5

DYNAMIC POWER DISSIPATION
VS
SWITCHING FREQUENCY (CD4051B)

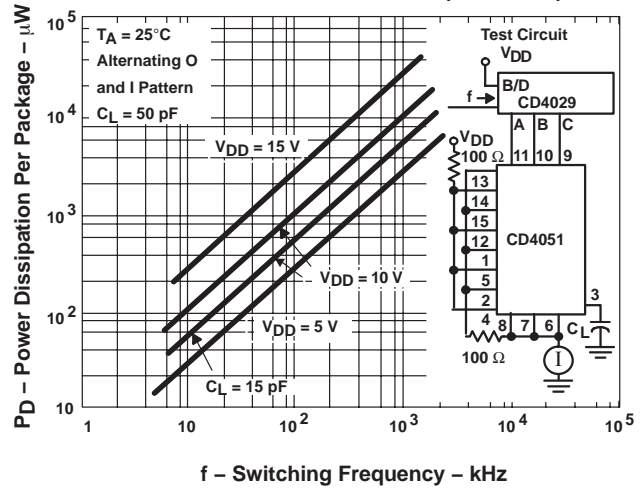

Figure 6

DYNAMIC POWER DISSIPATION
VS
SWITCHING FREQUENCY (CD4052B)

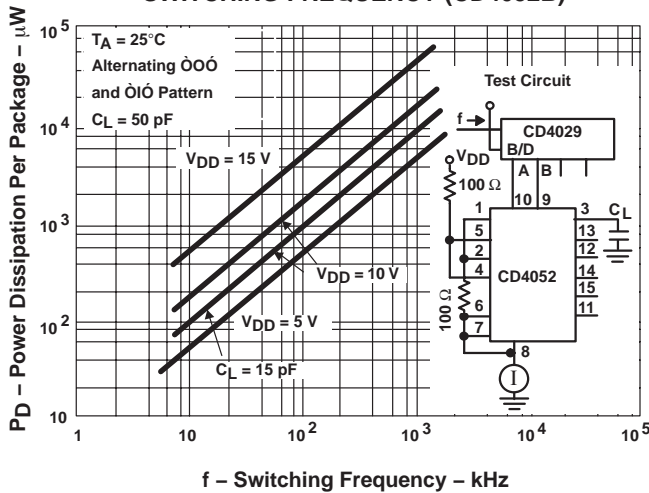

Figure 7

DYNAMIC POWER DISSIPATION
VS
SWITCHING FREQUENCY (CD4053B)

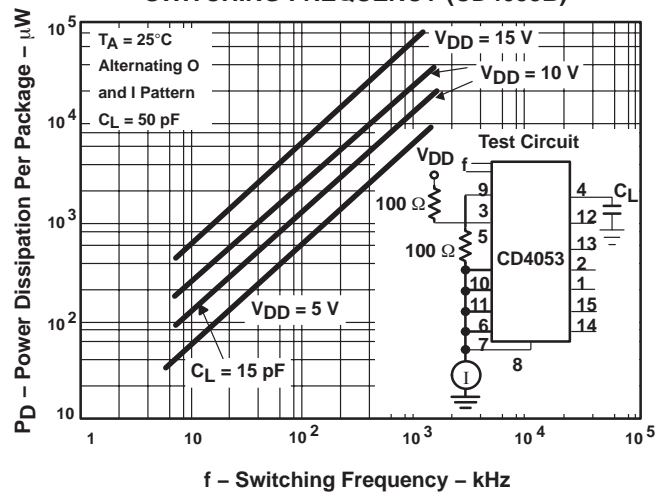
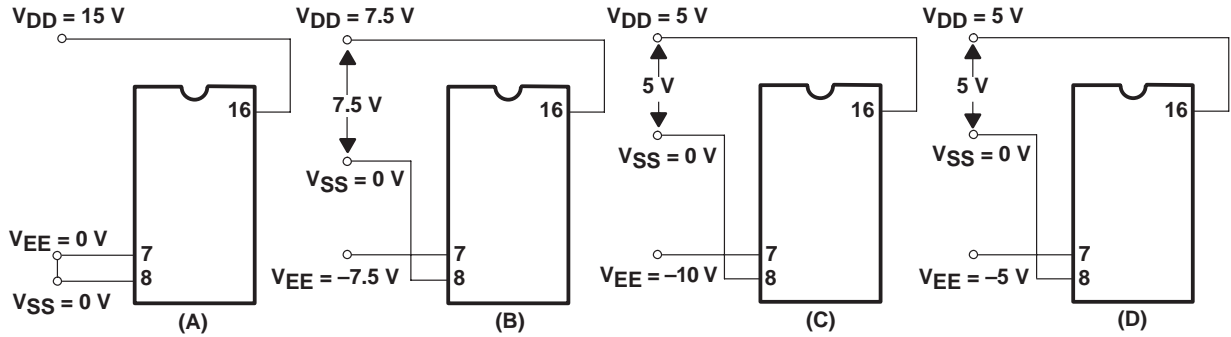

Figure 8

PARAMETER MEASUREMENT INFORMATION



NOTE: The A, B, C, and INH input logic levels are L = V_{SS} and H = V_{DD} . The analog signal (through the TG) may swing from V_{EE} to V_{DD} .

Figure 9. Typical Bias-Voltage Test Circuits

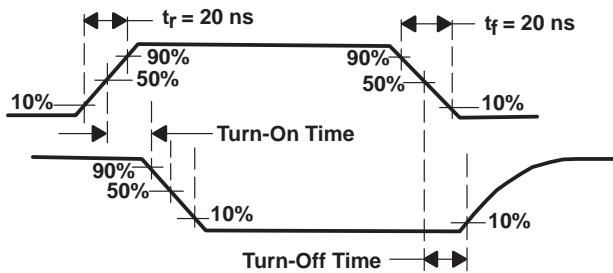

Figure 10. Channel Turned ON Waveforms
 ($R_L = 1\text{ k}\Omega$)

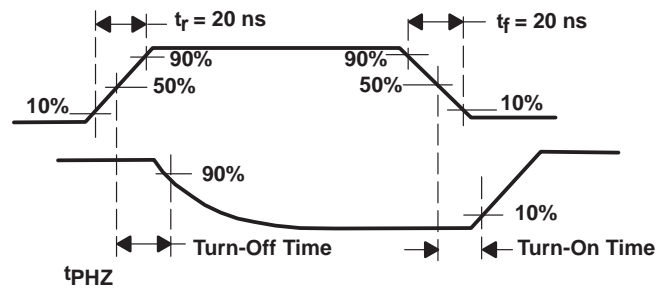

Figure 11. Channel Turned OFF Waveforms
 ($R_L = 1\text{ k}\Omega$)

CD4051B-Q1, CD4052B-Q1, CD4053B-Q1
CMOS ANALOG MULTIPLEXERS/DEMULTIPLEXERS
WITH LOGIC-LEVEL CONVERSION

SCHS354 – AUGUST 2004

PARAMETER MEASUREMENT INFORMATION

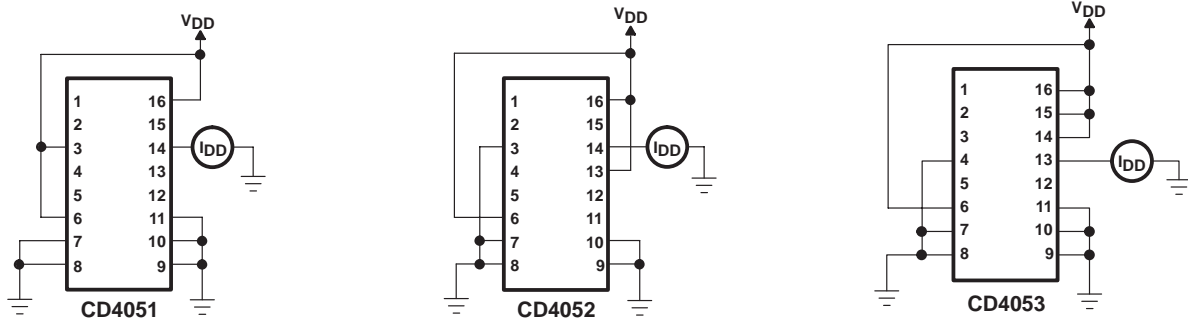

Figure 12. OFF Channel Leakage Current, Any Channel OFF

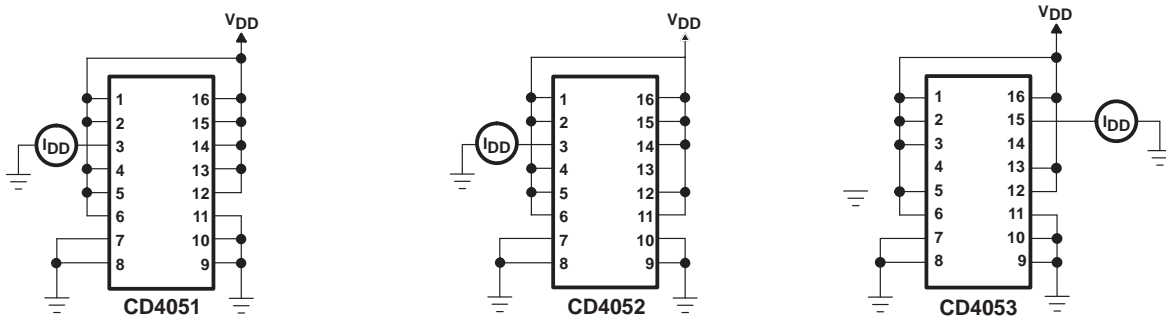

Figure 13. OFF Channel Leakage Current, All Channels OFF

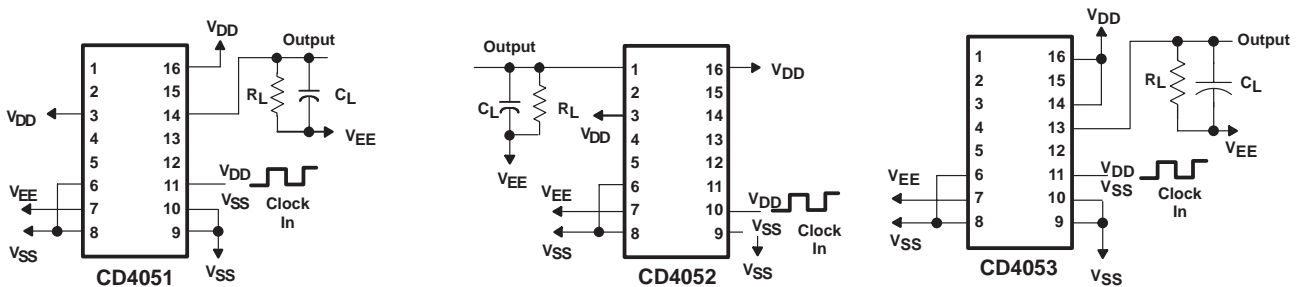

Figure 14. Propagation Delay, Address Input to Signal Output

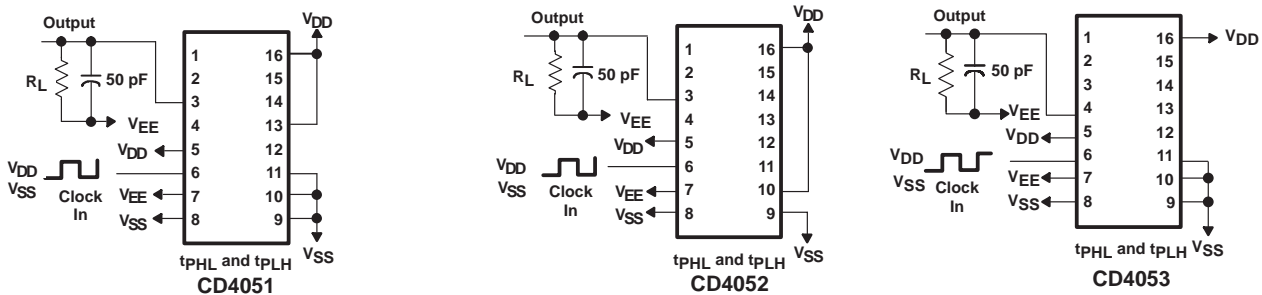
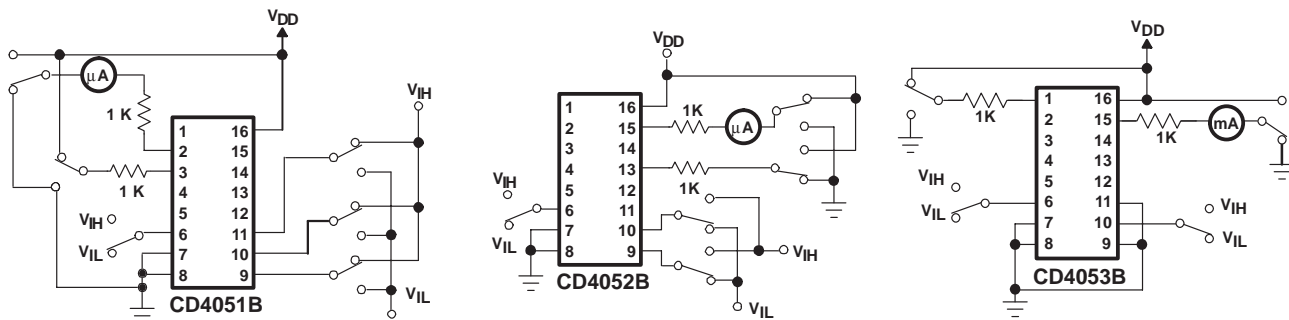

Figure 15. Propagation Delay, Inhibit Input to Signal Output

PARAMETER MEASUREMENT INFORMATION



Measure <2 μA on All OFF Channels (e.g., Channel 6)

Measure <2 μA on All OFF Channels (e.g., Channel 2x)

Measure <2 μA on All OFF Channels (e.g., Channel by)

Figure 16. Input-Voltage Test Circuit (Noise Immunity)

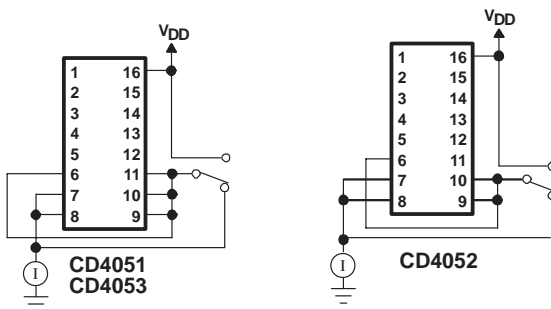

Figure 17. Quiescent Device Current

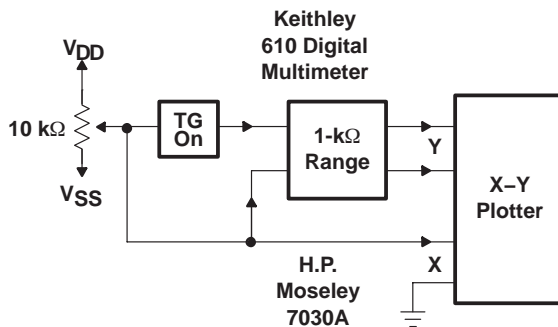
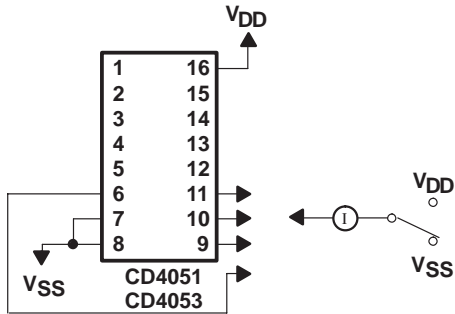

Figure 18. Channel ON-Resistance Test Circuit

CD4051B-Q1, CD4052B-Q1, CD4053B-Q1 CMOS ANALOG MULTIPLEXERS/DEMULTIPLEXERS WITH LOGIC-LEVEL CONVERSION

SCHS354 – AUGUST 2004

PARAMETER MEASUREMENT INFORMATION



NOTE: Measure inputs sequentially to both V_{DD} and V_{SS} . Connect all unused inputs to either V_{DD} or V_{SS} .

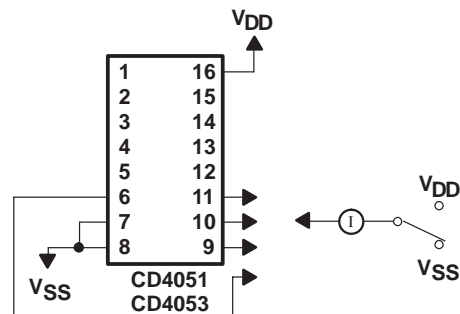

NOTE: Measure inputs sequentially to both V_{DD} and V_{SS} . Connect all unused inputs to either V_{DD} or V_{SS} .

Figure 19. Input Current

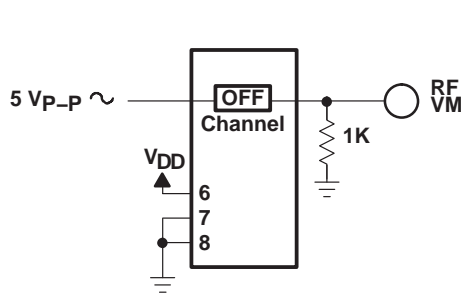

Figure 20. Feedthrough

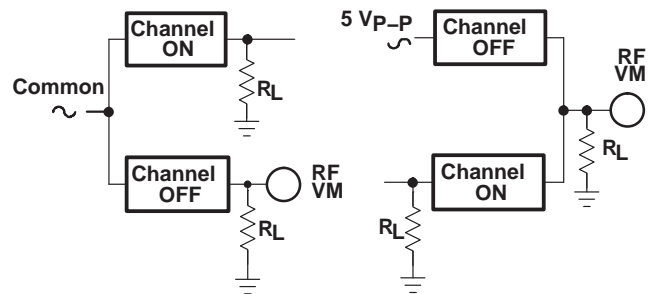

Figure 21. Crosstalk Between Any Two Channels

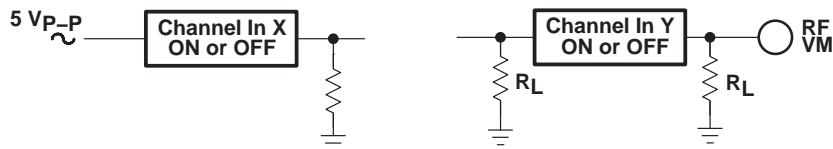

Figure 22. Crosstalk Between Duals or Triplets (CD4052B, CD4053B)

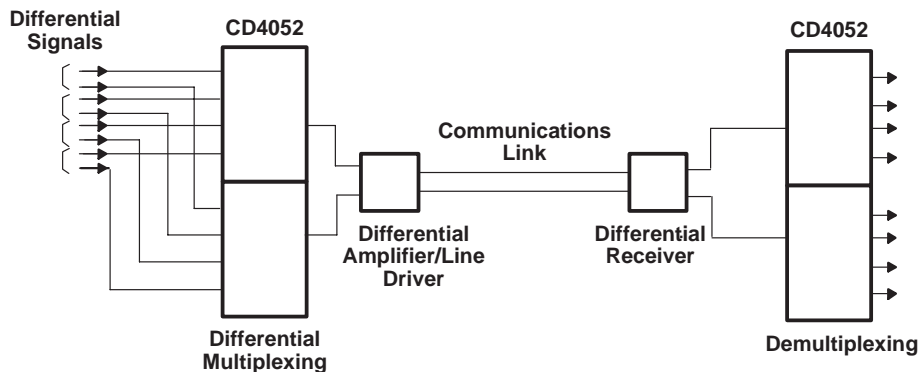

Figure 23. Typical Time-Division Application of the CD4052B

APPLICATION INFORMATION

In applications where separate power sources drive V_{DD} and the signal inputs, the V_{DD} current capability should exceed V_{DD}/R_L (R_L = effective external load). This provision avoids permanent current flow or clamp action on the V_{DD} supply when power is applied or removed from the CD4051B, CD4052B, or CD4053B.

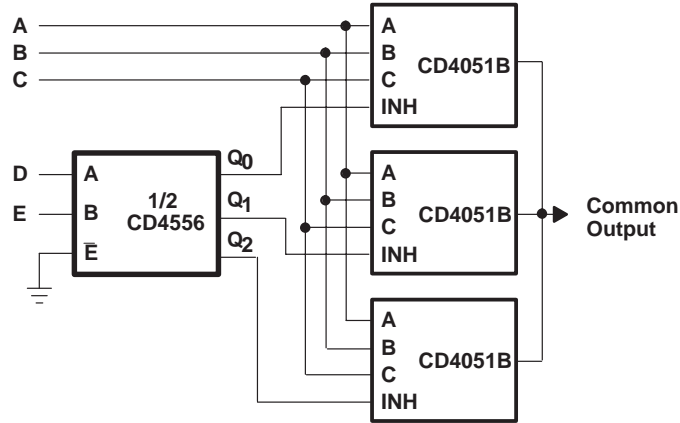
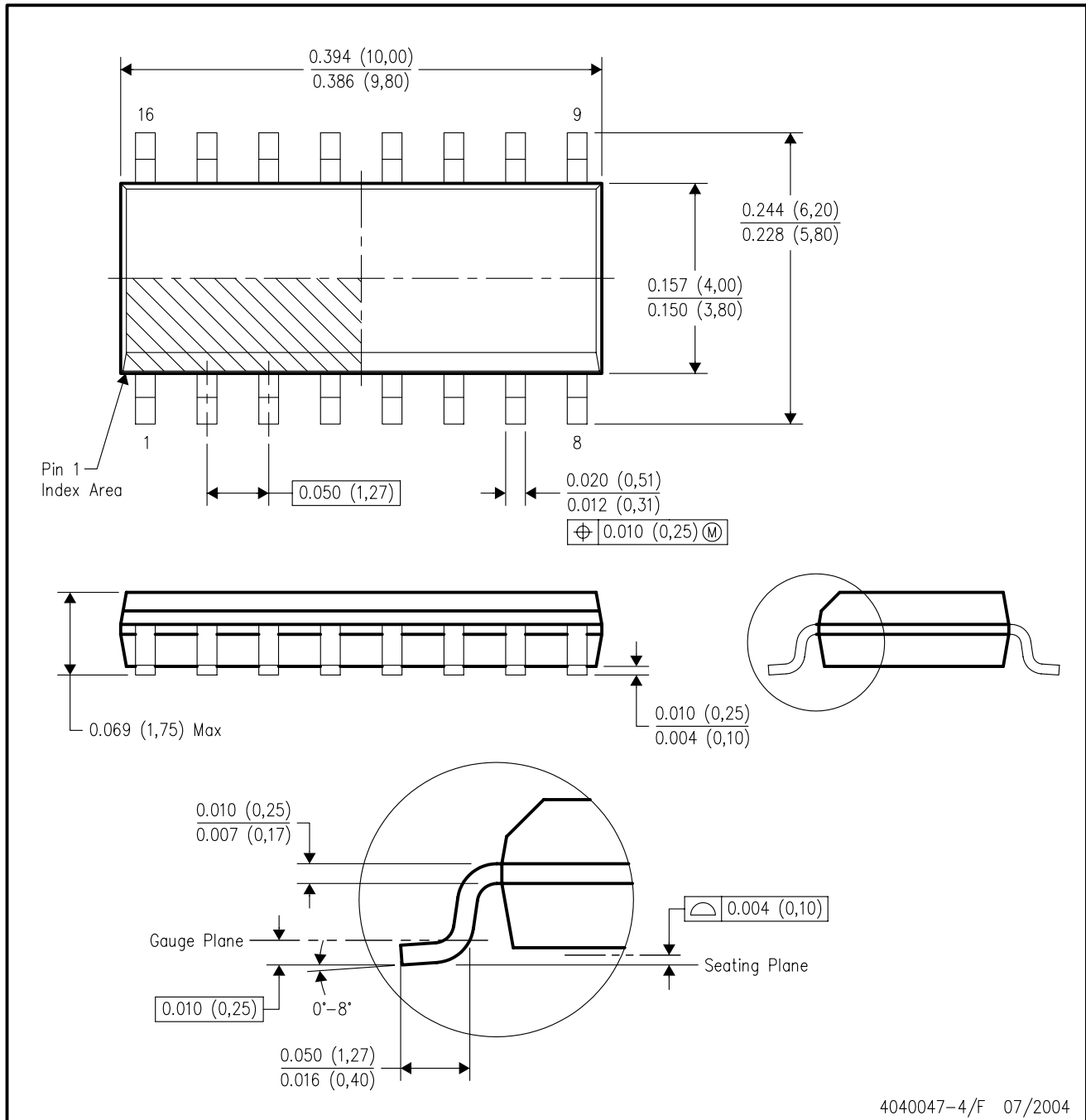

Figure 24. 24-to-1 Multiplexer Addressing

D (R-PDSO-G16)

PLASTIC SMALL-OUTLINE PACKAGE



- NOTES:
- A. All linear dimensions are in inches (millimeters).
 - B. This drawing is subject to change without notice.
 - C. Body dimensions do not include mold flash or protrusion not to exceed 0.006 (0,15).
 - D. Falls within JEDEC MS-012 variation AC.

PW (R-PDSO-G**)

PLASTIC SMALL-OUTLINE PACKAGE

14 PINS SHOWN



4040064/F 01/97

- NOTES: A. All linear dimensions are in millimeters.
 B. This drawing is subject to change without notice.
 C. Body dimensions do not include mold flash or protrusion not to exceed 0,15.
 D. Falls within JEDEC MO-153

IMPORTANT NOTICE

Texas Instruments Incorporated and its subsidiaries (TI) reserve the right to make corrections, modifications, enhancements, improvements, and other changes to its products and services at any time and to discontinue any product or service without notice. Customers should obtain the latest relevant information before placing orders and should verify that such information is current and complete. All products are sold subject to TI's terms and conditions of sale supplied at the time of order acknowledgment.

TI warrants performance of its hardware products to the specifications applicable at the time of sale in accordance with TI's standard warranty. Testing and other quality control techniques are used to the extent TI deems necessary to support this warranty. Except where mandated by government requirements, testing of all parameters of each product is not necessarily performed.

TI assumes no liability for applications assistance or customer product design. Customers are responsible for their products and applications using TI components. To minimize the risks associated with customer products and applications, customers should provide adequate design and operating safeguards.

TI does not warrant or represent that any license, either express or implied, is granted under any TI patent right, copyright, mask work right, or other TI intellectual property right relating to any combination, machine, or process in which TI products or services are used. Information published by TI regarding third-party products or services does not constitute a license from TI to use such products or services or a warranty or endorsement thereof. Use of such information may require a license from a third party under the patents or other intellectual property of the third party, or a license from TI under the patents or other intellectual property of TI.

Reproduction of information in TI data books or data sheets is permissible only if reproduction is without alteration and is accompanied by all associated warranties, conditions, limitations, and notices. Reproduction of this information with alteration is an unfair and deceptive business practice. TI is not responsible or liable for such altered documentation.

Resale of TI products or services with statements different from or beyond the parameters stated by TI for that product or service voids all express and any implied warranties for the associated TI product or service and is an unfair and deceptive business practice. TI is not responsible or liable for any such statements.

Following are URLs where you can obtain information on other Texas Instruments products and application solutions:

Products		Applications	
Amplifiers	amplifier.ti.com	Audio	www.ti.com/audio
Data Converters	dataconverter.ti.com	Automotive	www.ti.com/automotive
DSP	dsp.ti.com	Broadband	www.ti.com/broadband
Interface	interface.ti.com	Digital Control	www.ti.com/digitalcontrol
Logic	logic.ti.com	Military	www.ti.com/military
Power Mgmt	power.ti.com	Optical Networking	www.ti.com/opticalnetwork
Microcontrollers	microcontroller.ti.com	Security	www.ti.com/security
		Telephony	www.ti.com/telephony
		Video & Imaging	www.ti.com/video
		Wireless	www.ti.com/wireless

Mailing Address: Texas Instruments
Post Office Box 655303 Dallas, Texas 75265