

# CD4070B, CD4077B

## CMOS Quad Exclusive-OR and Exclusive-NOR Gate

### Features

- High-Voltage Types (20V Rating)
- CD4070B - Quad Exclusive-OR Gate
- CD4077B - Quad Exclusive-NOR Gate
- Medium Speed Operation
  - $t_{PHL}, t_{PLH} = 65\text{ns}$  (Typ) at  $V_{DD} = 10\text{V}, C_L = 50\text{pF}$
- 100% Tested for Quiescent Current at 20V
- Standardized Symmetrical Output Characteristics
- 5V, 10V and 15V Parametric Ratings
- Maximum Input Current of  $1\mu\text{A}$  at 18V Over Full Package Temperature Range
  - $100\text{nA}$  at 18V and  $25^\circ\text{C}$
- Noise Margin (Over Full Package Temperature Range)
  - 1V at  $V_{DD} = 5\text{V}$ , 2V at  $V_{DD} = 10\text{V}$ , 2.5V at  $V_{DD} = 15\text{V}$
- Meets All Requirements of JEDEC Standard No. 13B, "Standard Specifications for Description of 'B' Series CMOS Devices"

### Applications

- Logical Comparators
- Adders/Subtractors
- Parity Generators and Checkers

### Description

The Harris CD4070B contains four independent Exclusive-OR gates. The Harris CD4077B contains four independent Exclusive-NOR gates.

The CD4070B and CD4077B provide the system designer with a means for direct implementation of the Exclusive-OR and Exclusive-NOR functions, respectively.

### Ordering Information

PART NUMBER	TEMP. RANGE (°C)	PACKAGE
CD4070BE	-55 to 125	14 Ld PDIP
CD4070BF3A	-55 to 125	14 Ld Cerdip
CD4070BM	-55 to 125	14 Ld SOIC
CD4070BMT	-55 to 125	14 Ld SOIC
CD4070BM96	-55 to 125	14 Ld SOIC
CD4070BNSR	-55 to 125	14 Ld SOP
CD4070BPW	-55 to 125	14 Ld TSSOP
CD4070BPWR	-55 to 125	14 Ld TSSOP
CD4077BE	-55 to 125	14 Ld PDIP
CD4077BF3A	-55 to 125	14 Ld Cerdip
CD4077BM	-55 to 125	14 Ld SOIC
CD4077BMT	-55 to 125	14 Ld SOIC
CD4077BM96	-55 to 125	14 Ld SOIC
CD4077BNSR	-55 to 125	14 Ld SOP
CD4077BPW	-55 to 125	14 Ld TSSOP
CD4077BPWR	-55 to 125	14 Ld TSSOP

NOTE: When ordering, use the entire part number. The suffixes 96 and R denote tape and reel. The suffix T denotes a small-quantity reel of 250.

# CD4070B, CD4077B

## Pinouts

**CD4070B**  
(PDIP, Cerdip, SOIC, SOP, TSSOP)  
TOP VIEW

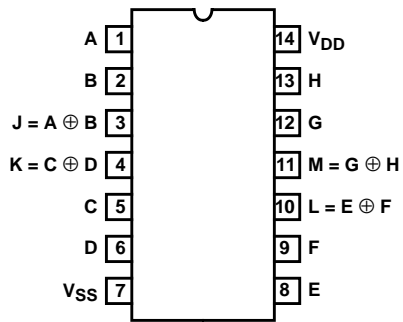

**CD4077B**  
(PDIP, Cerdip, SOIC, SOP, TSSOP)  
TOP VIEW

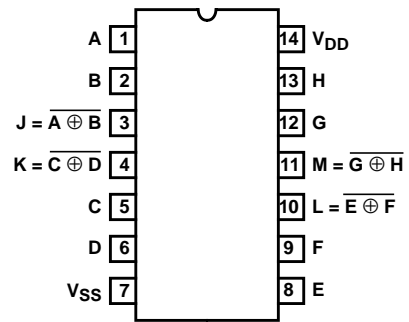

## Functional Diagrams

**CD4070B**

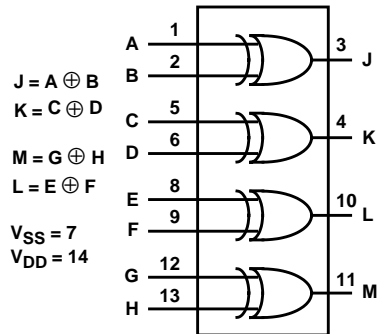

**CD4077B**

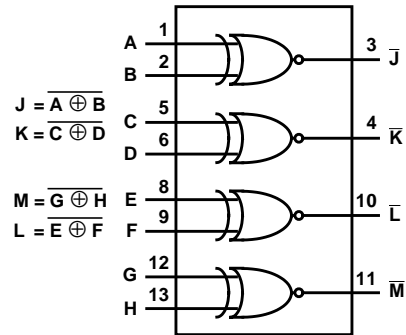

## CD4070B, CD4077B

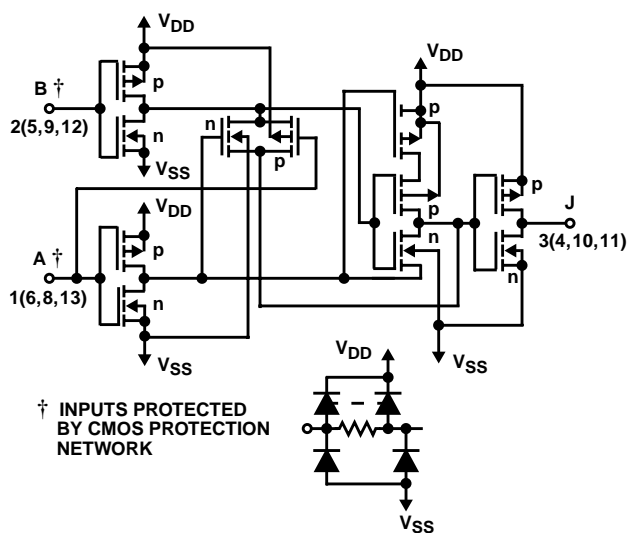

**FIGURE 1. SCHEMATIC DIAGRAM FOR CD4070B  
(1 OF 4 IDENTICAL GATES)**

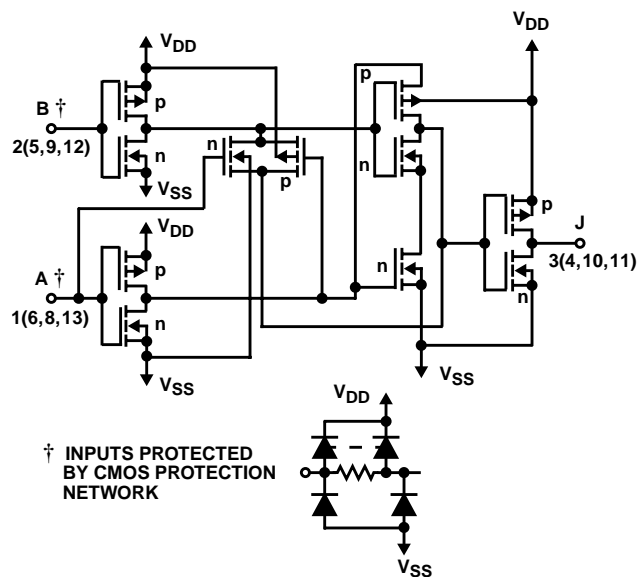

**FIGURE 2. SCHEMATIC DIAGRAM FOR CD4077B  
(1 OF 4 IDENTICAL GATES)**

**CD4070B TRUTH TABLE (1 OF 4 GATES)**

A	B	J
0	0	0
1	0	1
0	1	1
1	1	0

NOTE:  
 1 = High Level  
 0 = Low Level  
 J = A ⊕ B

**CD4077B TRUTH TABLE (1 OF 4 GATES)**

A	B	J
0	0	1
1	0	0
0	1	0
1	1	1

NOTE:  
 1 = High Level  
 0 = Low Level  
 J = A ⊕ B

## CD4070B, CD4077B

### Absolute Maximum Ratings

DC Supply Voltage Range ( $V_{DD}$ ) ..... -0.5V to 20V  
 Input Voltage Range, All Inputs ..... -0.5V to  $V_{DD}$  0.5V  
 DC Input Current .....  $\pm 10\text{mA}$

### Operating Conditions

Temperature Range ( $T_A$ ) ..... -55°C to 125°C  
 Supply Voltage Range (Typical) ..... 3V to 18V

### Thermal Information

Package Thermal Impedance,  $\theta_{JA}$  (see Note 1):  
 E (PDIP) Package ..... 80°C/W  
 M (SOIC) Package ..... 86°C/W  
 NS (SOP) Package ..... 76°C/W  
 PW (TSSOP) Package ..... 113°C/W  
 Maximum Junction Temperature (Hermetic Package or Die) . 175°C  
 Maximum Junction Temperature (Plastic Package) ..... 150°C  
 Maximum Storage Temperature Range ..... -65°C to 150°C

*CAUTION: Stresses above those listed in "Absolute Maximum Ratings" may cause permanent damage to the device. This is a stress only rating and operation of the device at these or any other conditions above those indicated in the operational sections of this specification is not implied.*

#### NOTE:

- The package thermal impedance is calculated in accordance with JESD 51-7.

### DC Electrical Specifications

PARAMETER	CONDITIONS			LIMITS AT INDICATED TEMPERATURES (°C)							UNITS
				-55	-40	85	125	25			
	$V_O$ (V)	$V_{IN}$ (V)	$V_{DD}$ (V)					MIN	TYP	MAX	
Quiescent Device Current $I_{DD}$ Max	-	0, 5	5	0.25	0.25	7.5	7.5	-	0.01	0.25	$\mu\text{A}$
	-	0, 10	10	0.5	0.5	15	15	-	0.01	0.5	$\mu\text{A}$
	-	0, 15	15	1	1	30	30	-	0.01	1	$\mu\text{A}$
	-	0, 20	20	5	5	150	150	-	0.02	5	$\mu\text{A}$
Output Low (Sink) Current $I_{OL}$ Min	0.4	0, 5	5	0.64	0.61	0.42	0.36	0.51	1	-	mA
	0.5	0, 10	10	1.6	1.5	1.1	0.9	1.3	2.6	-	mA
	1.5	0, 15	15	4.2	4	2.8	2.4	3.4	6.8	-	mA
Output High (Source) Current $I_{OH}$ Min	4.6	0, 5	5	-0.64	-0.61	-0.42	-0.36	-0.51	-1	-	mA
	2.5	0, 5	5	-2	-1.8	-1.3	-1.15	-1.6	-3.2	-	mA
	9.5	0, 10	10	-1.6	-1.5	-1.1	-0.9	-1.3	-2.6	-	mA
	13.5	0, 15	15	-4.2	-4	-2.8	-2.4	-3.4	-6.8	-	mA
Output Voltage: Low Level, $V_{OL}$ Max	-	0, 5	5	0.05	0.05	0.05	0.05	-	0	0.05	V
	-	0, 10	10	0.05	0.05	0.05	0.05	-	0	0.05	V
	-	0, 15	15	0.05	0.05	0.05	0.05	-	0	0.05	V
Output Voltage: High Level, $V_{OH}$ Min	-	0, 5	5	4.95	4.95	4.95	4.95	4.95	5	-	V
	-	0, 10	10	9.95	9.95	9.95	9.95	9.95	10	-	V
	-	0, 15	15	14.95	14.95	14.95	14.95	14.95	15	-	V
Input Low Voltage, $V_{IL}$ Max	0.5, 4.5	-	5	1.5	1.5	1.5	1.5	-	-	1.5	V
	1, 9	-	10	3	3	3	3	-	-	3	V
	1.5, 13.5	-	15	4	4	4	4	-	-	4	V
Input High Voltage, $V_{IH}$ Min	0.5, 4.5	-	5	3.5	3.5	3.5	3.5	3.5	-	-	V
	1, 9	-	10	7	7	7	7	7	-	-	V
	1.5, 13.5	-	15	11	11	11	11	11	-	-	V
Input Current, $I_{IN}$ Max	-	0, 18	18	$\pm 0.1$	$\pm 0.1$	$\pm 1$	$\pm 1$	-	$\pm 10^{-5}$	$\pm 0.1$	$\mu\text{A}$

# CD4070B, CD4077B

## AC Electrical Specifications

$T_A = 25^\circ\text{C}$ , Input  $t_r, t_f = 20\text{ns}$ ,  $C_L = 50\text{pF}$ ,  $R_L = 200\text{k}\Omega$

PARAMETER	SYMBOL	TEST CONDITIONS	LIMITS ON ALL TYPES		UNITS
		$V_{DD}$ (V)	TYP	MAX	
Propagation Delay Time	$t_{PHL}, t_{PLH}$	5	140	280	ns
		10	65	130	ns
		15	50	100	ns
Transition Time	$t_{THL}, t_{TLH}$	5	100	200	ns
		10	50	100	ns
		15	40	80	ns
Input Capacitance	$C_{IN}$	Any Input	5	7.5	pF

## Typical Performance Curves

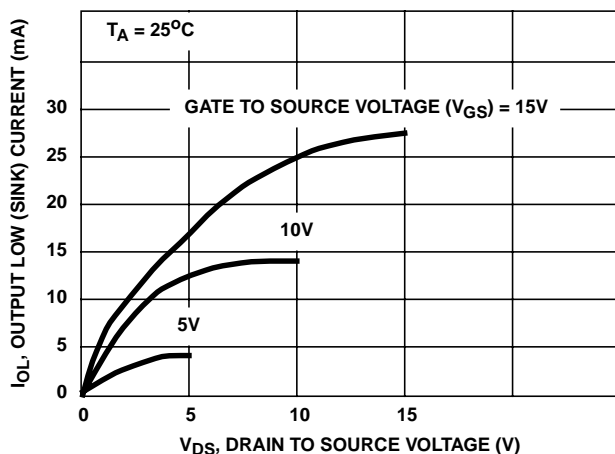

FIGURE 3. TYPICAL OUTPUT LOW (SINK) CURRENT CHARACTERISTICS

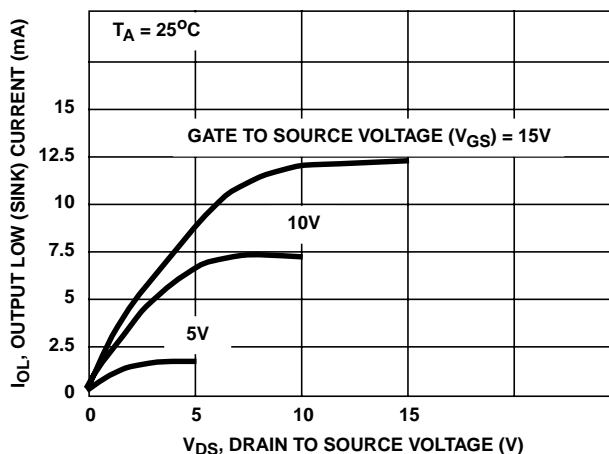

FIGURE 4. MINIMUM OUTPUT LOW (SINK) CURRENT CHARACTERISTICS

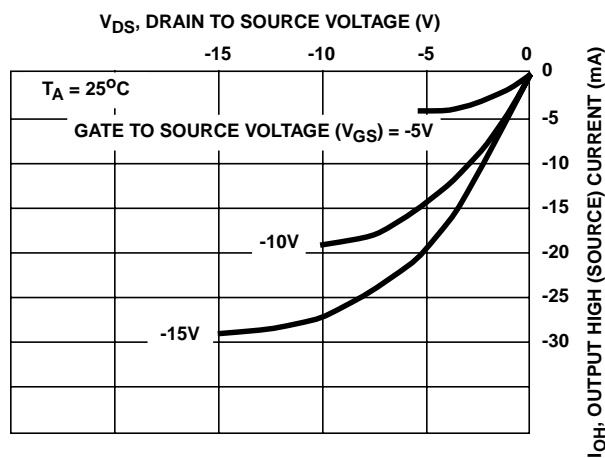

FIGURE 5. TYPICAL OUTPUT HIGH (SOURCE) CURRENT CHARACTERISTICS

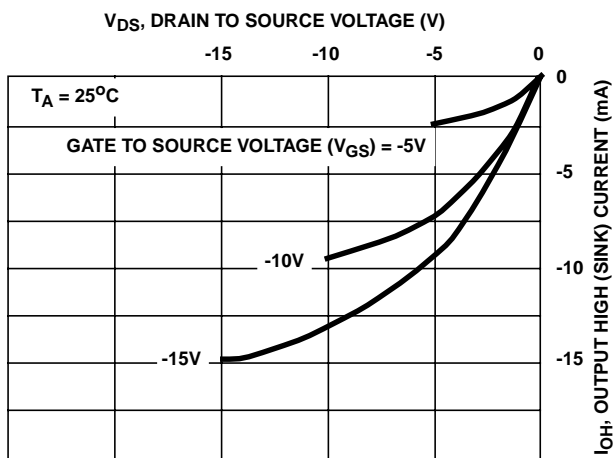

FIGURE 6. MINIMUM OUTPUT HIGH (SOURCE) CURRENT CHARACTERISTICS

**Typical Performance Curves** (Continued)

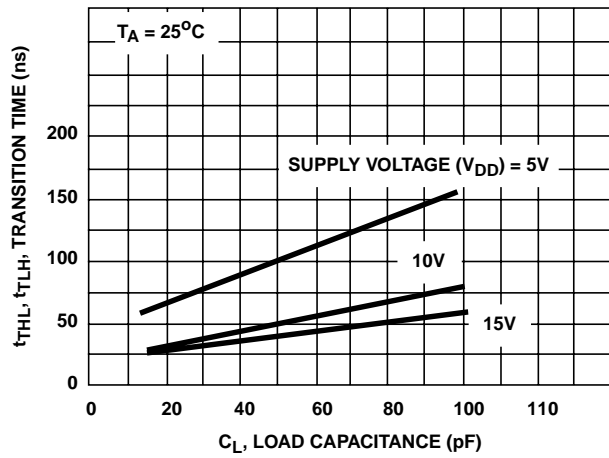

FIGURE 7. TYPICAL TRANSITION TIME AS A FUNCTION OF LOAD CAPACITANCE

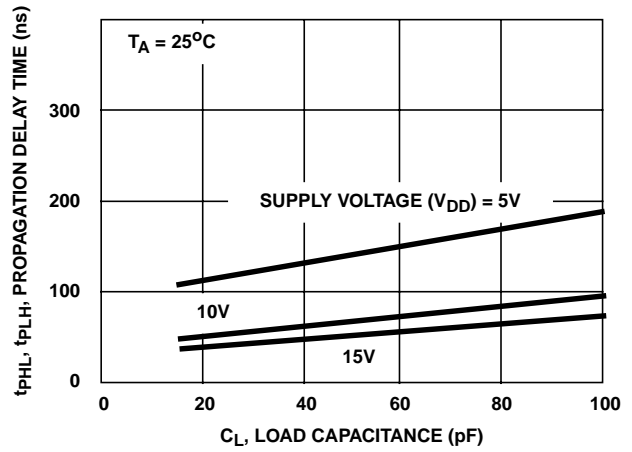

FIGURE 8. TYPICAL PROPAGATION DELAY TIME AS A FUNCTION OF LOAD CAPACITANCE

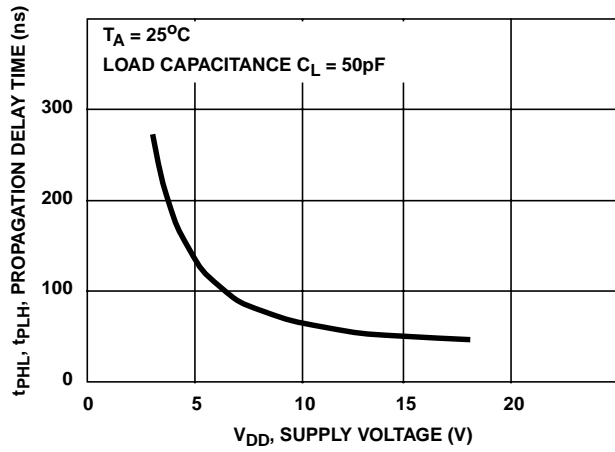

FIGURE 9. TYPICAL PROPAGATION DELAY TIME AS A FUNCTION OF SUPPLY VOLTAGE

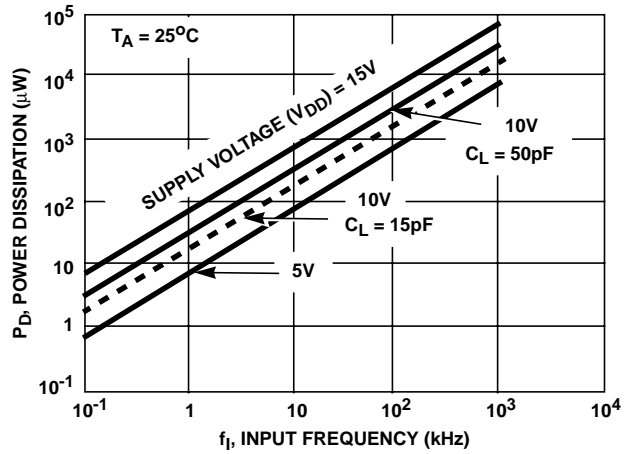

FIGURE 10. TYPICAL DYNAMIC POWER DISSIPATION AS A FUNCTION OF INPUT FREQUENCY

PACKAGING INFORMATION

Orderable Device	Status <sup>(1)</sup>	Package Type	Package Drawing	Pins	Package Qty	Eco Plan <sup>(2)</sup>	Lead/Ball Finish	MSL Peak Temp <sup>(3)</sup>
CD4070BE	ACTIVE	PDIP	N	14	25	Pb-Free (RoHS)	CU NIPDAU	Level-NC-NC-NC
CD4070BF	ACTIVE	CDIP	J	14	1	None	Call TI	Level-NC-NC-NC
CD4070BF3A	ACTIVE	CDIP	J	14	1	None	Call TI	Level-NC-NC-NC
CD4070BM	ACTIVE	SOIC	D	14	50	Pb-Free (RoHS)	CU NIPDAU	Level-2-260C-1 YEAR/ Level-1-235C-UNLIM
CD4070BM96	ACTIVE	SOIC	D	14	2500	Pb-Free (RoHS)	CU NIPDAU	Level-2-260C-1 YEAR/ Level-1-235C-UNLIM
CD4070BMT	ACTIVE	SOIC	D	14	250	Pb-Free (RoHS)	CU NIPDAU	Level-2-260C-1 YEAR/ Level-1-235C-UNLIM
CD4070BNSR	ACTIVE	SO	NS	14	2000	Pb-Free (RoHS)	CU NIPDAU	Level-2-260C-1 YEAR/ Level-1-235C-UNLIM
CD4070BPW	ACTIVE	TSSOP	PW	14	90	Pb-Free (RoHS)	CU NIPDAU	Level-1-250C-UNLIM
CD4070BPWR	ACTIVE	TSSOP	PW	14	2000	Pb-Free (RoHS)	CU NIPDAU	Level-1-250C-UNLIM
CD4077BE	ACTIVE	PDIP	N	14	25	Pb-Free (RoHS)	CU NIPDAU	Level-NC-NC-NC
CD4077BF	ACTIVE	CDIP	J	14	1	None	Call TI	Level-NC-NC-NC
CD4077BF3A	ACTIVE	CDIP	J	14	1	None	Call TI	Level-NC-NC-NC
CD4077BM	ACTIVE	SOIC	D	14	50	Pb-Free (RoHS)	CU NIPDAU	Level-2-260C-1 YEAR/ Level-1-235C-UNLIM
CD4077BM96	ACTIVE	SOIC	D	14	2500	Pb-Free (RoHS)	CU NIPDAU	Level-2-260C-1 YEAR/ Level-1-235C-UNLIM
CD4077BMT	ACTIVE	SOIC	D	14	250	Pb-Free (RoHS)	CU NIPDAU	Level-2-260C-1 YEAR/ Level-1-235C-UNLIM
CD4077BNSR	ACTIVE	SO	NS	14	2000	Pb-Free (RoHS)	CU NIPDAU	Level-2-260C-1 YEAR/ Level-1-235C-UNLIM
CD4077BPW	ACTIVE	TSSOP	PW	14	90	Pb-Free (RoHS)	CU NIPDAU	Level-1-250C-UNLIM
CD4077BPWR	ACTIVE	TSSOP	PW	14	2000	Pb-Free (RoHS)	CU NIPDAU	Level-1-250C-UNLIM
JM38510/17203BCA	ACTIVE	CDIP	J	14	1	None	Call TI	Level-NC-NC-NC

<sup>(1)</sup> The marketing status values are defined as follows:

**ACTIVE:** Product device recommended for new designs.

**LIFEBUY:** TI has announced that the device will be discontinued, and a lifetime-buy period is in effect.

**NRND:** Not recommended for new designs. Device is in production to support existing customers, but TI does not recommend using this part in a new design.

**PREVIEW:** Device has been announced but is not in production. Samples may or may not be available.

**OBSELETE:** TI has discontinued the production of the device.

<sup>(2)</sup> Eco Plan - May not be currently available - please check <http://www.ti.com/productcontent> for the latest availability information and additional product content details.

**None:** Not yet available Lead (Pb-Free).

**Pb-Free (RoHS):** TI's terms "Lead-Free" or "Pb-Free" mean semiconductor products that are compatible with the current RoHS requirements for all 6 substances, including the requirement that lead not exceed 0.1% by weight in homogeneous materials. Where designed to be soldered at high temperatures, TI Pb-Free products are suitable for use in specified lead-free processes.

**Green (RoHS & no Sb/Br):** TI defines "Green" to mean "Pb-Free" and in addition, uses package materials that do not contain halogens, including bromine (Br) or antimony (Sb) above 0.1% of total product weight.

<sup>(3)</sup> MSL, Peak Temp. -- The Moisture Sensitivity Level rating according to the JEDEC industry standard classifications, and peak solder temperature.

**Important Information and Disclaimer:** The information provided on this page represents TI's knowledge and belief as of the date that it is provided. TI bases its knowledge and belief on information provided by third parties, and makes no representation or warranty as to the accuracy of such information. Efforts are underway to better integrate information from third parties. TI has taken and continues to take reasonable steps to provide representative and accurate information but may not have conducted destructive testing or chemical analysis on incoming materials and chemicals. TI and TI suppliers consider certain information to be proprietary, and thus CAS numbers and other limited information may not be available for release.

In no event shall TI's liability arising out of such information exceed the total purchase price of the TI part(s) at issue in this document sold by TI to Customer on an annual basis.

J (R-GDIP-T\*\*)

14 LEADS SHOWN

CERAMIC DUAL IN-LINE PACKAGE



DIM \ PINS **	14	16	18	20
A	0.300 (7,62) BSC	0.300 (7,62) BSC	0.300 (7,62) BSC	0.300 (7,62) BSC
B MAX	0.785 (19,94)	.840 (21,34)	0.960 (24,38)	1.060 (26,92)
B MIN	—	—	—	—
C MAX	0.300 (7,62)	0.300 (7,62)	0.310 (7,87)	0.300 (7,62)
C MIN	0.245 (6,22)	0.245 (6,22)	0.220 (5,59)	0.245 (6,22)



4040083/F 03/03

- NOTES:
- All linear dimensions are in inches (millimeters).
  - This drawing is subject to change without notice.
  - This package is hermetically sealed with a ceramic lid using glass frit.
  - Index point is provided on cap for terminal identification only on press ceramic glass frit seal only.
  - Falls within MIL STD 1835 GDIP1-T14, GDIP1-T16, GDIP1-T18 and GDIP1-T20.

N (R-PDIP-T\*\*)

PLASTIC DUAL-IN-LINE PACKAGE

16 PINS SHOWN



4040049/E 12/2002

- NOTES:
- A. All linear dimensions are in inches (millimeters).
  - B. This drawing is subject to change without notice.
  - $\triangle C$  Falls within JEDEC MS-001, except 18 and 20 pin minimum body length (Dim A).
  - $\triangle D$  The 20 pin end lead shoulder width is a vendor option, either half or full width.

D (R-PDSO-G14)

PLASTIC SMALL-OUTLINE PACKAGE



- NOTES:
- A. All linear dimensions are in inches (millimeters).
  - B. This drawing is subject to change without notice.
  - C. Body dimensions do not include mold flash or protrusion not to exceed 0.006 (0,15).
  - D. Falls within JEDEC MS-012 variation AB.

# MECHANICAL DATA

NS (R-PDSO-G\*\*)

PLASTIC SMALL-OUTLINE PACKAGE

14-PINS SHOWN



- NOTES:
- A. All linear dimensions are in millimeters.
  - B. This drawing is subject to change without notice.
  - C. Body dimensions do not include mold flash or protrusion, not to exceed 0,15.

PW (R-PDSO-G\*\*)

PLASTIC SMALL-OUTLINE PACKAGE

14 PINS SHOWN



4040064/F 01/97

- NOTES: A. All linear dimensions are in millimeters.  
 B. This drawing is subject to change without notice.  
 C. Body dimensions do not include mold flash or protrusion not to exceed 0,15.  
 D. Falls within JEDEC MO-153

## IMPORTANT NOTICE

Texas Instruments Incorporated and its subsidiaries (TI) reserve the right to make corrections, modifications, enhancements, improvements, and other changes to its products and services at any time and to discontinue any product or service without notice. Customers should obtain the latest relevant information before placing orders and should verify that such information is current and complete. All products are sold subject to TI's terms and conditions of sale supplied at the time of order acknowledgment.

TI warrants performance of its hardware products to the specifications applicable at the time of sale in accordance with TI's standard warranty. Testing and other quality control techniques are used to the extent TI deems necessary to support this warranty. Except where mandated by government requirements, testing of all parameters of each product is not necessarily performed.

TI assumes no liability for applications assistance or customer product design. Customers are responsible for their products and applications using TI components. To minimize the risks associated with customer products and applications, customers should provide adequate design and operating safeguards.

TI does not warrant or represent that any license, either express or implied, is granted under any TI patent right, copyright, mask work right, or other TI intellectual property right relating to any combination, machine, or process in which TI products or services are used. Information published by TI regarding third-party products or services does not constitute a license from TI to use such products or services or a warranty or endorsement thereof. Use of such information may require a license from a third party under the patents or other intellectual property of the third party, or a license from TI under the patents or other intellectual property of TI.

Reproduction of information in TI data books or data sheets is permissible only if reproduction is without alteration and is accompanied by all associated warranties, conditions, limitations, and notices. Reproduction of this information with alteration is an unfair and deceptive business practice. TI is not responsible or liable for such altered documentation.

Resale of TI products or services with statements different from or beyond the parameters stated by TI for that product or service voids all express and any implied warranties for the associated TI product or service and is an unfair and deceptive business practice. TI is not responsible or liable for any such statements.

Following are URLs where you can obtain information on other Texas Instruments products and application solutions:

<b>Products</b>		<b>Applications</b>	
Amplifiers	<a href="http://amplifier.ti.com">amplifier.ti.com</a>	Audio	<a href="http://www.ti.com/audio">www.ti.com/audio</a>
Data Converters	<a href="http://dataconverter.ti.com">dataconverter.ti.com</a>	Automotive	<a href="http://www.ti.com/automotive">www.ti.com/automotive</a>
DSP	<a href="http://dsp.ti.com">dsp.ti.com</a>	Broadband	<a href="http://www.ti.com/broadband">www.ti.com/broadband</a>
Interface	<a href="http://interface.ti.com">interface.ti.com</a>	Digital Control	<a href="http://www.ti.com/digitalcontrol">www.ti.com/digitalcontrol</a>
Logic	<a href="http://logic.ti.com">logic.ti.com</a>	Military	<a href="http://www.ti.com/military">www.ti.com/military</a>
Power Mgmt	<a href="http://power.ti.com">power.ti.com</a>	Optical Networking	<a href="http://www.ti.com/opticalnetwork">www.ti.com/opticalnetwork</a>
Microcontrollers	<a href="http://microcontroller.ti.com">microcontroller.ti.com</a>	Security	<a href="http://www.ti.com/security">www.ti.com/security</a>
		Telephony	<a href="http://www.ti.com/telephony">www.ti.com/telephony</a>
		Video & Imaging	<a href="http://www.ti.com/video">www.ti.com/video</a>
		Wireless	<a href="http://www.ti.com/wireless">www.ti.com/wireless</a>

Mailing Address: Texas Instruments  
Post Office Box 655303 Dallas, Texas 75265