

**CD74HC138-Q1**  
**HIGH-SPEED CMOS LOGIC**  
**3- TO 8-LINE INVERTING DECODER/DEMULTIPLEXER**

SCLS580 – APRIL 2004

- Qualification in Accordance With AEC-Q100†
- Qualified for Automotive Applications
- Customer-Specific Configuration Control Can Be Supported Along With Major-Change Approval
- Select One of Eight Data Outputs Active Low
- I/O Port or Memory Selector
- Three Enable Inputs to Simplify Cascading
- Typical Propagation Delay of 13 ns at  $V_{CC} = 5\text{ V}$ ,  $C_L = 15\text{ pF}$ ,  $T_A = 25^\circ\text{C}$
- Fanout (Over Temperature Range)
  - Standard Outputs . . . 10 LSTTL Loads
  - Bus Driver Outputs . . . 15 LSTTL Loads
- Balanced Propagation Delay and Transition Times
- Significant Power Reduction Compared to LSTTL Logic ICs
- 2-V to 6-V  $V_{CC}$  Operation
- High Noise Immunity;  $N_{IL}$  or  $N_{IH} = 30\%$  of  $V_{CC}$ ,  $V_{CC} = 5\text{ V}$

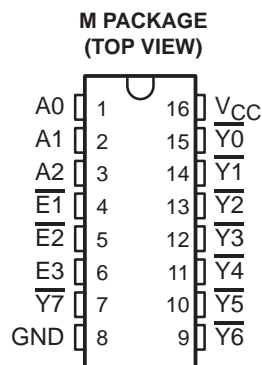

† Contact factory for details. Q100 qualification data available on request.

### description/ordering information

The CD74HC138 is a high-speed silicon-gate CMOS decoder well suited to memory address decoding or data routing applications. This circuit features low power consumption usually associated with CMOS circuitry, yet has speeds comparable to low-power Schottky TTL logic. The circuit has three binary select inputs (A0, A1, and A2). If the device is enabled, these inputs determine which one of the eight normally high outputs of the HC138 will go low.

Two active-low and one active-high enables ( $\overline{E1}$ ,  $\overline{E2}$ , and E3) are provided to ease the cascading of decoders. The decoder's eight outputs can drive ten low-power Schottky TTL equivalent loads.

### ORDERING INFORMATION

| T <sub>A</sub> | PACKAGE‡ |              | ORDERABLE PART NUMBER | TOP-SIDE MARKING |
|----------------|----------|--------------|-----------------------|------------------|
|                | SOIC – M | Reel of 2500 |                       |                  |
| –40°C to 125°C | SOIC – M | Reel of 2500 | CD74HC138QM96Q1       | HC138Q           |

‡ Package drawings, standard packing quantities, thermal data, symbolization, and PCB design guidelines are available at [www.ti.com/sc/package](http://www.ti.com/sc/package).



Please be aware that an important notice concerning availability, standard warranty, and use in critical applications of Texas Instruments semiconductor products and disclaimers thereto appears at the end of this data sheet.

PRODUCTION DATA information is current as of publication date. Products conform to specifications per the terms of Texas Instruments standard warranty. Production processing does not necessarily include testing of all parameters.



POST OFFICE BOX 655303 • DALLAS, TEXAS 75265

Copyright © 2004, Texas Instruments Incorporated

**CD74HC138-Q1**  
**HIGH-SPEED CMOS LOGIC**  
**3- TO 8-LINE INVERTING DECODER/DEMULTIPLEXER**

SCLS580 – APRIL 2004

FUNCTION TABLE

| ENABLE INPUTS |                 |                 | SELECT INPUTS |    |    | OUTPUTS         |                 |                 |                 |                 |                 |                 |                 |
|---------------|-----------------|-----------------|---------------|----|----|-----------------|-----------------|-----------------|-----------------|-----------------|-----------------|-----------------|-----------------|
| E3            | $\overline{E2}$ | $\overline{E1}$ | A2            | A1 | A0 | $\overline{Y0}$ | $\overline{Y1}$ | $\overline{Y2}$ | $\overline{Y3}$ | $\overline{Y4}$ | $\overline{Y5}$ | $\overline{Y6}$ | $\overline{Y7}$ |
| X             | X               | H               | X             | X  | X  | H               | H               | H               | H               | H               | H               | H               | H               |
| L             | X               | X               | X             | X  | X  | H               | H               | H               | H               | H               | H               | H               | H               |
| X             | H               | X               | X             | X  | X  | H               | H               | H               | H               | H               | H               | H               | H               |
| H             | L               | L               | L             | L  | L  | L               | H               | H               | H               | H               | H               | H               | H               |
| H             | L               | L               | L             | L  | H  | H               | L               | H               | H               | H               | H               | H               | H               |
| H             | L               | L               | L             | H  | L  | H               | H               | L               | H               | H               | H               | H               | H               |
| H             | L               | L               | L             | H  | H  | H               | H               | L               | H               | H               | H               | H               | H               |
| H             | L               | L               | H             | L  | L  | H               | H               | H               | H               | L               | H               | H               | H               |
| H             | L               | L               | H             | L  | H  | H               | H               | H               | H               | H               | L               | H               | H               |
| H             | L               | L               | H             | H  | L  | H               | H               | H               | H               | H               | H               | L               | H               |
| H             | L               | L               | H             | H  | H  | H               | H               | H               | H               | H               | H               | H               | L               |

NOTE: H = High voltage level, L = Low voltage level, X = Don't care

logic diagram (positive logic)

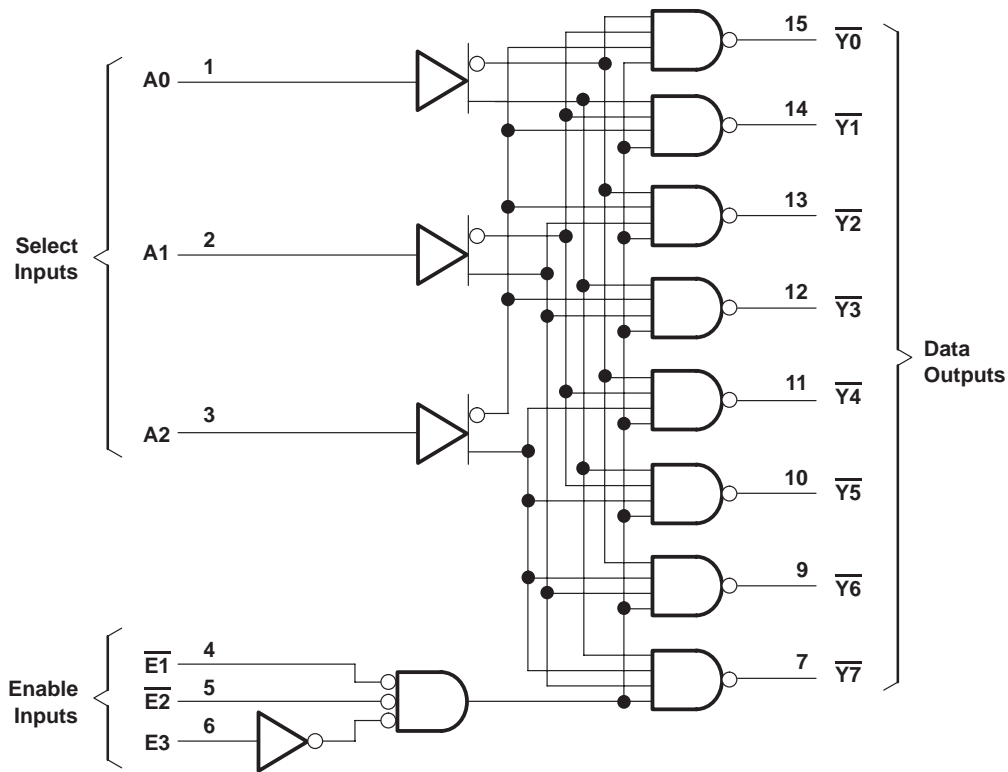

**CD74HC138-Q1**  
**HIGH-SPEED CMOS LOGIC**  
**3- TO 8-LINE INVERTING DECODER/DEMULTIPLEXER**

SCLS580 – APRIL 2004

**absolute maximum ratings over operating free-air temperature range (unless otherwise noted)†**

|  |                |
|--|----------------|
| Supply voltage range, $V_{CC}$ (see Note 1)  | –0.5 V to 7 V  |
| Input clamp current, $I_{IK}$ ( $V_I < -0.5$ V or $V_I > V_{CC} + 0.5$ V)                | ±20 mA         |
| Output clamp current, $I_{OK}$ ( $V_O < -0.5$ V or $V_O > V_{CC} + 0.5$ V)               | ±20 mA         |
| Source or sink current per output pin, $I_O$ ( $V_O > -0.5$ V or $V_O < V_{CC} + 0.5$ V) | ±25 mA         |
| Continuous current through $V_{CC}$ or GND   | ±50 mA         |
| Package thermal impedance, $\theta_{JA}$ (see Note 2)                                    | 73°C/W         |
| Storage temperature range, $T_{stg}$   | –65°C to 150°C |

† Stresses beyond those listed under “absolute maximum ratings” may cause permanent damage to the device. These are stress ratings only, and functional operation of the device at these or any other conditions beyond those indicated under “recommended operating conditions” is not implied. Exposure to absolute-maximum-rated conditions for extended periods may affect device reliability.

- NOTES: 1. All voltages referenced to GND unless otherwise specified.  
2. The package thermal impedance is calculated in accordance with JESD 51-7.

**recommended operating conditions (see Note 3)**

|          |                                       | MIN              | MAX      | UNIT |    |
|----------|---------------------------------------|------------------|----------|------|----|
| $V_{CC}$ | Supply voltage                        | 2                | 6        | V    |    |
| $V_{IH}$ | High-level input voltage              | $V_{CC} = 2$ V   | 1.5      | V    |    |
|          |                                       | $V_{CC} = 4.5$ V | 3.15     |      |    |
|          |                                       | $V_{CC} = 6$ V   | 4.2      |      |    |
| $V_{IL}$ | Low-level input voltage               | $V_{CC} = 2$ V   | 0.5      | V    |    |
|          |                                       | $V_{CC} = 4.5$ V | 1.35     |      |    |
|          |                                       | $V_{CC} = 6$ V   | 1.8      |      |    |
| $V_I$    | Input voltage                         | 0                | $V_{CC}$ | V    |    |
| $V_O$    | Output voltage                        | 0                | $V_{CC}$ | V    |    |
| $t_t$    | Input transition (rise and fall) time | $V_{CC} = 2$ V   | 0        | 1000 | ns |
|          |                                       | $V_{CC} = 4.5$ V | 0        | 500  |    |
|          |                                       | $V_{CC} = 6$ V   | 0        | 400  |    |
| $T_A$    | Operating free-air temperature        | –40              | 125      | °C   |    |

- NOTES: 3. All unused inputs of the device must be held at  $V_{CC}$  or GND to ensure proper device operation. Refer to the TI application report, *Implications of Slow or Floating CMOS Inputs*, literature number SCBA004.



**CD74HC138-Q1**  
**HIGH-SPEED CMOS LOGIC**  
**3- TO 8-LINE INVERTING DECODER/DEMULTIPLEXER**

SCLS580 – APRIL 2004

electrical characteristics over recommended operating free-air temperature range (unless otherwise noted)

| PARAMETER       | TEST CONDITIONS                                     |            | I <sub>O</sub><br>(mA) | V <sub>CC</sub> | T <sub>A</sub> = 25°C |     |      | T <sub>A</sub> = -40°C<br>TO 125°C |     | UNIT |
|-----------------|---|------------|------------------------|-----------------|-----------------------|-----|------|------------------------------------|-----|------|
|                 |   |            |                        |                 | MIN                   | TYP | MAX  | MIN                                | MAX |      |
| V <sub>OH</sub> | V <sub>I</sub> = V <sub>IH</sub> or V <sub>IL</sub> | CMOS loads | -0.02                  | 2 V             | 1.9                   |     |      | 1.9                                | V   |      |
|                 |   |            | -0.02                  | 4.5 V           | 4.4                   |     | 4.4  |                                    |     |      |
|                 |   |            | -0.02                  | 6 V             | 5.9                   |     | 5.9  |                                    |     |      |
|                 |   | TTL loads  | -4                     | 4.5 V           | 3.98                  |     | 3.7  |                                    |     |      |
|                 |   |            | -5.2                   | 6 V             | 5.48                  |     | 5.2  |                                    |     |      |
| V <sub>OL</sub> | V <sub>I</sub> = V <sub>IH</sub> or V <sub>IL</sub> | CMOS loads | 0.02                   | 2 V             |                       |     | 0.1  | 0.1                                | V   |      |
|                 |   |            | 0.02                   | 4.5 V           |                       |     | 0.1  | 0.1                                |     |      |
|                 |   |            | 0.02                   | 6 V             |                       |     | 0.1  | 0.1                                |     |      |
|                 |   | TTL loads  | 4                      | 4.5 V           |                       |     | 0.26 | 0.4                                |     |      |
|                 |   |            | 5.2                    | 6 V             |                       |     | 0.26 | 0.4                                |     |      |
| I <sub>I</sub>  | V <sub>I</sub> = V <sub>CC</sub> or GND             |            |                        | 6 V             |                       |     | ±0.1 | ±1                                 | μA  |      |
| I <sub>CC</sub> | V <sub>I</sub> = V <sub>CC</sub> or GND             |            | 0                      | 6 V             |                       |     | 8    | 160                                | μA  |      |
| C <sub>IN</sub> |   |            |                        |                 |                       |     | 10   | 10                                 | pF  |      |

switching characteristics over recommended operating free-air temperature range (unless otherwise noted) (see Figure 1)

| PARAMETER       | FROM<br>(INPUT) | TO<br>(OUTPUT) | LOAD<br>CAPACITANCE    | V <sub>CC</sub> | T <sub>A</sub> = 25°C |     |     | T <sub>A</sub> = -40°C<br>TO 125°C |     | UNIT |
|-----------------|-----------------|----------------|------------------------|-----------------|-----------------------|-----|-----|------------------------------------|-----|------|
|                 |                 |                |                        |                 | MIN                   | TYP | MAX | MIN                                | MAX |      |
| t <sub>pd</sub> | A               | Y              | C <sub>L</sub> = 15 pF | 5 V             |                       | 13  |     |                                    | ns  |      |
|                 |                 |                |                        | 2 V             |                       | 150 |     | 225                                |     |      |
|                 |                 |                | C <sub>L</sub> = 50 pF | 4.5 V           |                       | 30  |     | 45                                 |     |      |
|                 |                 |                |                        | 6 V             |                       | 26  |     | 38                                 |     |      |
|                 | E               | Y              | C <sub>L</sub> = 50 pF | 2 V             |                       | 150 |     | 265                                |     |      |
|                 |                 |                |                        | 4.5 V           |                       | 30  |     | 53                                 |     |      |
| t <sub>t</sub>  |                 | Y              | C <sub>L</sub> = 50 pF | 2 V             |                       | 75  |     | 110                                | ns  |      |
|                 |                 |                |                        | 4.5 V           |                       | 15  |     | 22                                 |     |      |
|                 |                 |                |                        | 6 V             |                       | 13  |     | 19                                 |     |      |

operating characteristics, V<sub>CC</sub> = 5 V, T<sub>A</sub> = 25°C, Input t<sub>r</sub>, t<sub>f</sub> = 6 ns, C<sub>L</sub> = 15 pF

| PARAMETER  | TYP | UNIT |
|--|-----|------|
| C <sub>pd</sub> Power dissipation capacitance (see Note 4) | 67  | pF   |

NOTE 4: C<sub>pd</sub> is used to determine the dynamic power consumption, per gate.

$$P_D = V_{CC}^2 f_I (C_{pd} + C_L)$$

f<sub>I</sub> = input frequency

C<sub>L</sub> = output load capacitance

V<sub>CC</sub> = supply voltage



**PARAMETER MEASUREMENT INFORMATION**

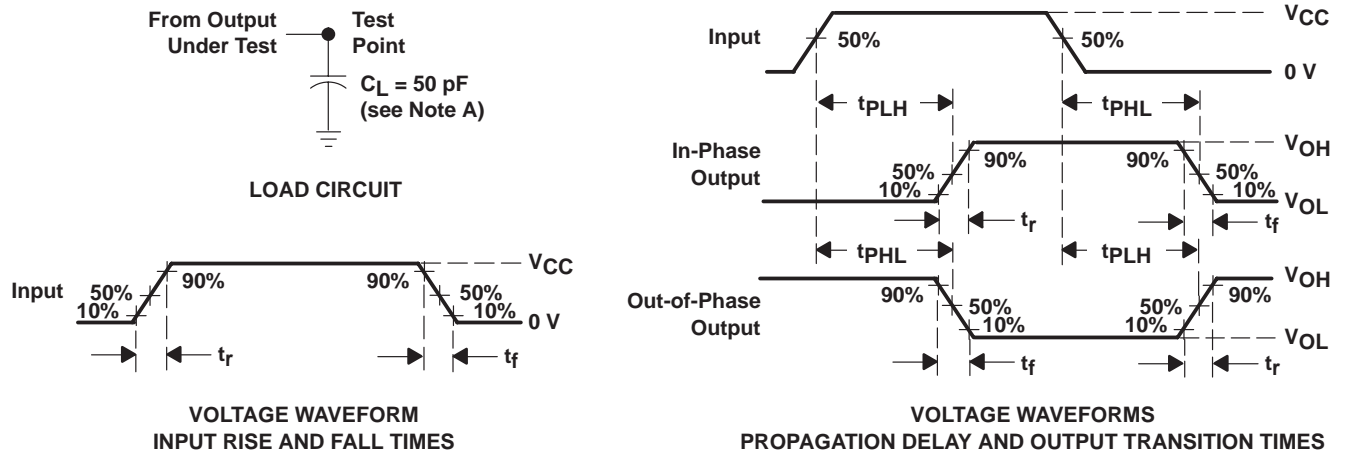

- NOTES: A.  $C_L$  includes probe and test-fixture capacitance.  
 B. Phase relationships between waveforms were chosen arbitrarily. All input pulses are supplied by generators having the following characteristics:  $PRR \leq 1 \text{ MHz}$ ,  $Z_O = 50 \Omega$ ,  $t_r = 6 \text{ ns}$ ,  $t_f = 6 \text{ ns}$ .  
 C. The outputs are measured one at a time, with one input transition per measurement.  
 D.  $t_{PLH}$  and  $t_{PHL}$  are the same as  $t_{pd}$ .

**Figure 1. Load Circuit and Voltage Waveforms**

D (R-PDSO-G16)

PLASTIC SMALL-OUTLINE PACKAGE

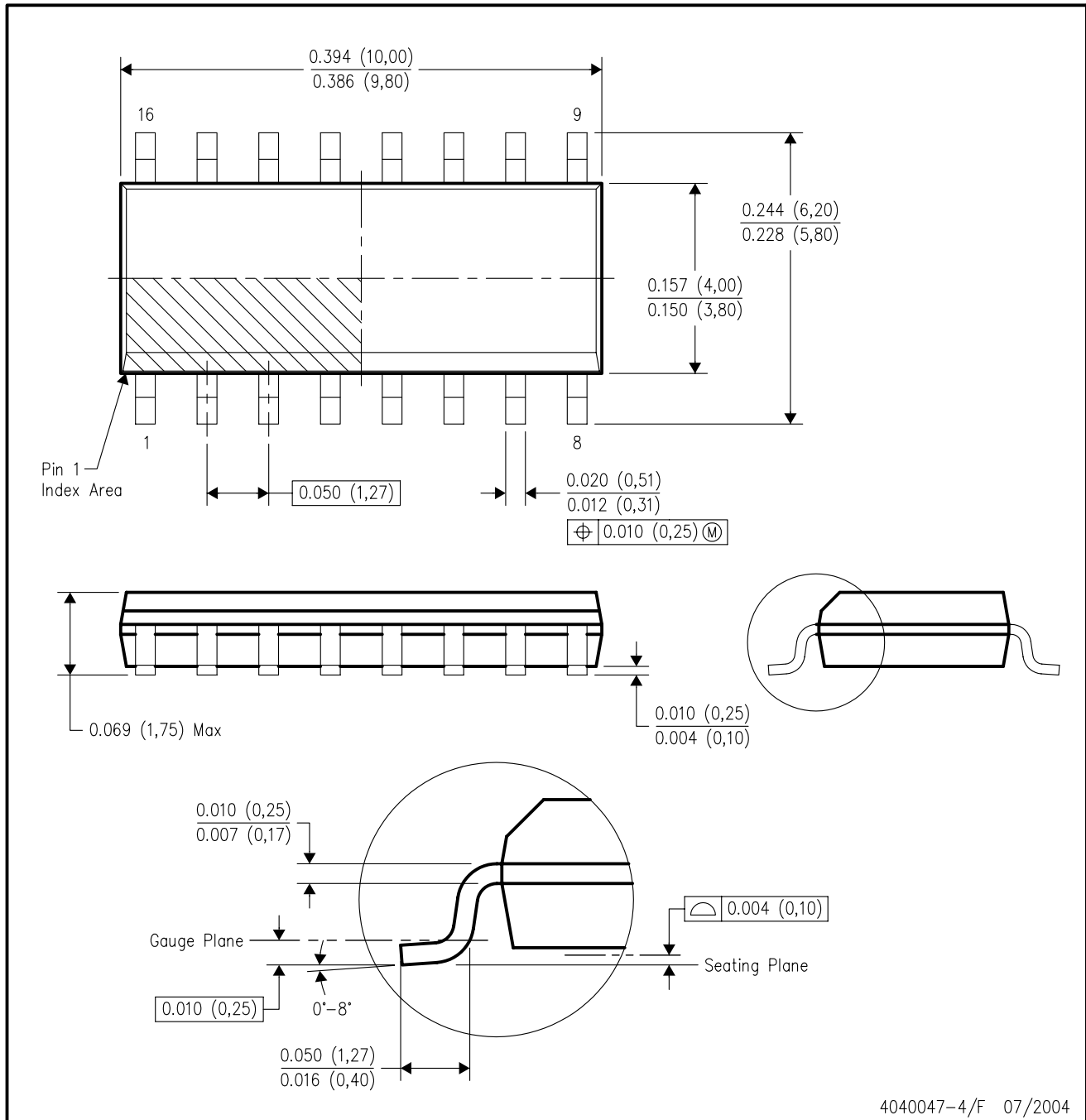

- NOTES:
- A. All linear dimensions are in inches (millimeters).
  - B. This drawing is subject to change without notice.
  - C. Body dimensions do not include mold flash or protrusion not to exceed 0.006 (0,15).
  - D. Falls within JEDEC MS-012 variation AC.

## IMPORTANT NOTICE

Texas Instruments Incorporated and its subsidiaries (TI) reserve the right to make corrections, modifications, enhancements, improvements, and other changes to its products and services at any time and to discontinue any product or service without notice. Customers should obtain the latest relevant information before placing orders and should verify that such information is current and complete. All products are sold subject to TI's terms and conditions of sale supplied at the time of order acknowledgment.

TI warrants performance of its hardware products to the specifications applicable at the time of sale in accordance with TI's standard warranty. Testing and other quality control techniques are used to the extent TI deems necessary to support this warranty. Except where mandated by government requirements, testing of all parameters of each product is not necessarily performed.

TI assumes no liability for applications assistance or customer product design. Customers are responsible for their products and applications using TI components. To minimize the risks associated with customer products and applications, customers should provide adequate design and operating safeguards.

TI does not warrant or represent that any license, either express or implied, is granted under any TI patent right, copyright, mask work right, or other TI intellectual property right relating to any combination, machine, or process in which TI products or services are used. Information published by TI regarding third-party products or services does not constitute a license from TI to use such products or services or a warranty or endorsement thereof. Use of such information may require a license from a third party under the patents or other intellectual property of the third party, or a license from TI under the patents or other intellectual property of TI.

Reproduction of information in TI data books or data sheets is permissible only if reproduction is without alteration and is accompanied by all associated warranties, conditions, limitations, and notices. Reproduction of this information with alteration is an unfair and deceptive business practice. TI is not responsible or liable for such altered documentation.

Resale of TI products or services with statements different from or beyond the parameters stated by TI for that product or service voids all express and any implied warranties for the associated TI product or service and is an unfair and deceptive business practice. TI is not responsible or liable for any such statements.

Following are URLs where you can obtain information on other Texas Instruments products and application solutions:

| <b>Products</b>  |  | <b>Applications</b> |  |
|------------------|--|---------------------|--|
| Amplifiers       | <a href="http://amplifier.ti.com">amplifier.ti.com</a>             | Audio               | <a href="http://www.ti.com/audio">www.ti.com/audio</a>                   |
| Data Converters  | <a href="http://dataconverter.ti.com">dataconverter.ti.com</a>     | Automotive          | <a href="http://www.ti.com/automotive">www.ti.com/automotive</a>         |
| DSP              | <a href="http://dsp.ti.com">dsp.ti.com</a>                         | Broadband           | <a href="http://www.ti.com/broadband">www.ti.com/broadband</a>           |
| Interface        | <a href="http://interface.ti.com">interface.ti.com</a>             | Digital Control     | <a href="http://www.ti.com/digitalcontrol">www.ti.com/digitalcontrol</a> |
| Logic            | <a href="http://logic.ti.com">logic.ti.com</a>                     | Military            | <a href="http://www.ti.com/military">www.ti.com/military</a>             |
| Power Mgmt       | <a href="http://power.ti.com">power.ti.com</a>                     | Optical Networking  | <a href="http://www.ti.com/opticalnetwork">www.ti.com/opticalnetwork</a> |
| Microcontrollers | <a href="http://microcontroller.ti.com">microcontroller.ti.com</a> | Security            | <a href="http://www.ti.com/security">www.ti.com/security</a>             |
|                  |  | Telephony           | <a href="http://www.ti.com/telephony">www.ti.com/telephony</a>           |
|                  |  | Video & Imaging     | <a href="http://www.ti.com/video">www.ti.com/video</a>                   |
|                  |  | Wireless            | <a href="http://www.ti.com/wireless">www.ti.com/wireless</a>             |

Mailing Address: Texas Instruments  
Post Office Box 655303 Dallas, Texas 75265