

CDC319 1-LINE TO 10-LINE CLOCK DRIVER WITH I²C CONTROL INTERFACE

SCAS590A – DECEMBER 1997 – REVISED OCTOBER 2001

- **High-Speed, Low-Skew 1-to-10 Clock Buffer for SDRAM (Synchronous DRAM) Clock Buffering Applications**
- **Output Skew, $t_{sk(o)}$, Less Than 250 ps**
- **Pulse Skew, $t_{sk(p)}$, Less Than 500 ps**
- **Supports up to Two Unbuffered SDRAM DIMMs (Dual Inline Memory Modules)**
- **I²C Serial Interface Provides Individual Enable Control for Each Output**
- **Operates at 3.3 V**
- **Distributed V_{CC} and Ground Pins Reduce Switching Noise**
- **ESD Protection Exceeds 2000 V Per MIL-STD-883, Method 3015**
- **Packaged in 28-Pin Shrink Small Outline (DB) Package**

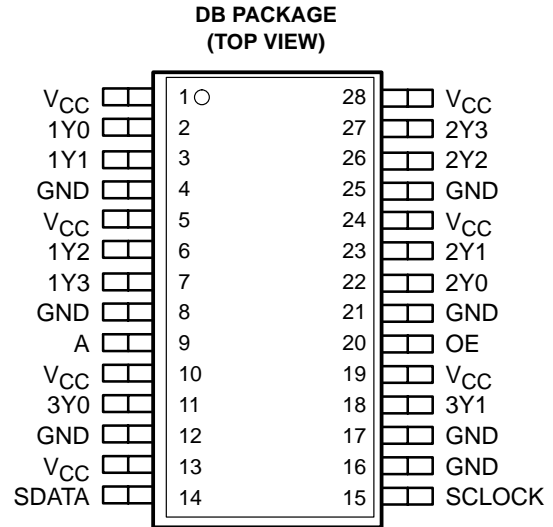

description

The CDC319 is a high-performance clock buffer that distributes one input (A) to 10 outputs (Y) with minimum skew for clock distribution. The CDC319 operates from a 3.3-V power supply, and is characterized for operation from 0°C to 70°C.

The device provides a standard mode (100K-bits/s) I²C serial interface for device control. The implementation is as a slave/receiver. The device address is specified in the I²C device address table. Both of the I²C inputs (SDATA and SCLOCK) provide integrated pullup resistors (typically 140 kΩ) and are 5-V tolerant.

Three 8-bit I²C registers provide individual enable control for each of the outputs. All outputs default to enabled at powerup. Each output can be placed in a disabled mode with a low-level output when a low-level control bit is written to the control register. The registers are write only and must be accessed in sequential order (i.e., random access of the registers is not supported).

The CDC319 provides 3-state outputs for testing and debugging purposes. The outputs can be placed in a high-impedance state via the output-enable (OE) input. When OE is high, all outputs are in the operational state. When OE is low, the outputs are placed in a high-impedance state. OE provides an integrated pullup resistor.



Please be aware that an important notice concerning availability, standard warranty, and use in critical applications of Texas Instruments semiconductor products and disclaimers thereto appears at the end of this data sheet.

PRODUCTION DATA information is current as of publication date. Products conform to specifications per the terms of Texas Instruments standard warranty. Production processing does not necessarily include testing of all parameters.

**TEXAS
INSTRUMENTS**

POST OFFICE BOX 655303 • DALLAS, TEXAS 75265

Copyright © 2001, Texas Instruments Incorporated

CDC319

1-LINE TO 10-LINE CLOCK DRIVER WITH I²C CONTROL INTERFACE

SCAS590A – DECEMBER 1997 – REVISED OCTOBER 2001

FUNCTION TABLE

INPUTS		OUTPUTS		
OE	A	1Y0–1Y3	2Y0–2Y3	3Y0–3Y1
L	X	Hi-Z	Hi-Z	Hi-Z
H	L	L	L	L
H	H	H [†]	H [†]	H [†]

[†]The function table assumes that all outputs are enabled via the appropriate I²C configuration register bit. If the output is disabled via the appropriate configuration bit, then the output is driven to a low state, regardless of the state of the A input.

logic diagram (positive logic)

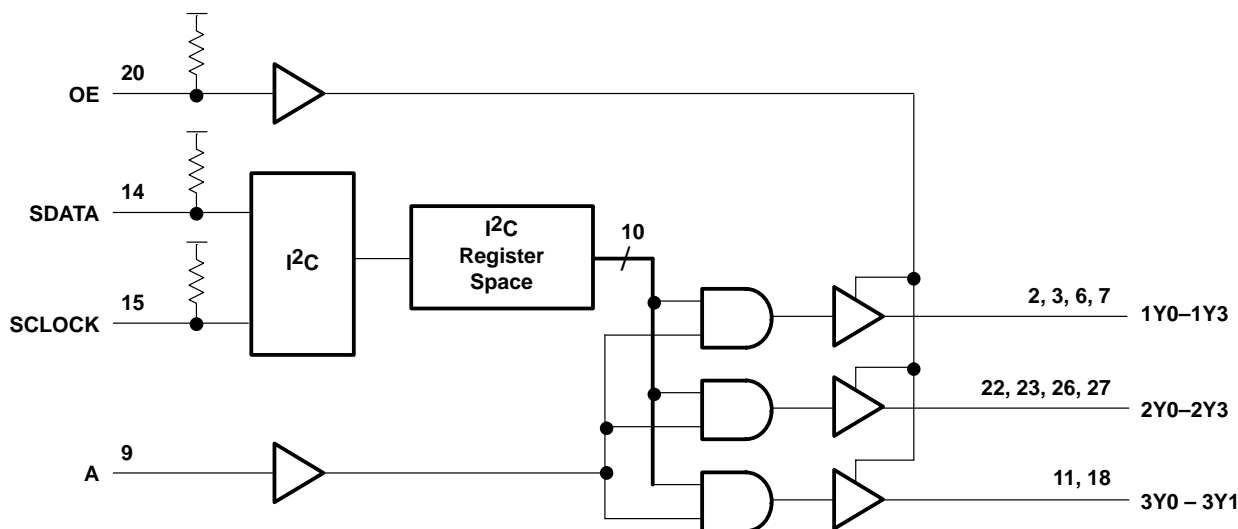

Terminal Functions

TERMINAL NAME	TERMINAL NO.	I/O	DESCRIPTION
1Y0–1Y3	2, 3, 6, 7	O	3.3-V SDRAM byte 0 clock outputs
2Y0–2Y3	22, 23, 26, 27	O	3.3-V SDRAM byte 1 clock outputs
3Y0–3Y1	11, 18	O	3.3-V clock outputs provided for feedback control of external PLLs (phase-locked loops)
A	9	I	Clock input
OE	20	I	Output enable. When asserted, OE puts all outputs in a high-impedance state. A nominal 140-kΩ pullup resistor is internally integrated.
SCLOCK	15	I	I ² C serial clock input. A nominal 140-kΩ pullup resistor is internally integrated.
SDATA	14	I/O	Bidirectional I ² C serial data input/output. A nominal 140-kΩ pullup resistor is internally integrated.
GND	4, 8, 12, 16, 17, 21, 25		Ground
VCC	1, 5, 10, 13, 19, 24, 28		3.3-V power supply

I²C DEVICE ADDRESS

A7	A6	A5	A4	A3	A2	A1	A0 (R/W)
H	H	L	H	L	L	H	—

I²C BYTE 0-BIT DEFINITION†

BIT	DEFINITION	DEFAULT VALUE
7	Reserved	H
6	Reserved	H
5	Reserved	H
4	Reserved	H
3	1Y3 enable (pin 7)	H
2	1Y2 enable (pin 6)	H
1	1Y1 enable (pin 3)	H
0	1Y0 enable (pin 2)	H

† When the value of the bit is high, the output is enabled.
 When the value of the bit is low, the output is forced to a low state. The default value of all bits is high.

I²C BYTE 1-BIT DEFINITION†

BIT	DEFINITION	DEFAULT VALUE
7	2Y3 enable (pin 27)	H
6	2Y2 enable (pin 26)	H
5	2Y1 enable (pin 23)	H
4	2Y0 enable (pin 22)	H
3	Reserved	H
2	Reserved	H
1	Reserved	H
0	Reserved	H

† When the value of the bit is high, the output is enabled.
 When the value of the bit is low, the output is forced to a low state. The default value of all bits is high.

I²C BYTE 2-BIT DEFINITION†

BIT	DEFINITION	DEFAULT VALUE
7	3Y1 enable (pin 18)	H
6	3Y0 enable (pin 11)	H
5	Reserved	H
4	Reserved	H
3	Reserved	H
2	Reserved	H
1	Reserved	H
0	Reserved	H

† When the value of the bit is high, the output is enabled.
 When the value of the bit is low, the output is forced to a low state. The default value of all bits is high.

CDC319

1-LINE TO 10-LINE CLOCK DRIVER WITH I²C CONTROL INTERFACE

SCAS590A – DECEMBER 1997 – REVISED OCTOBER 2001

absolute maximum ratings over operating free-air temperature range (unless otherwise noted)[†]

Supply voltage range, V_{CC}	–0.5 V to 4.6 V
Input voltage range, V_I (see Note 1)	–0.5 V to 4.6 V
Input voltage range, V_I (SCLOCK, SDATA) (see Note 1)	–0.5 V to 6.5 V
Output voltage range, V_O (SDATA) (see Note 1)	–0.5 V to 6.5 V
Voltage range applied to any output in the high-impedance or power-off state, V_O	–0.5 V to $V_{CC} + 0.5$ V
Current into any output in the low state (except SDATA), I_O	48 mA
Current into SDATA in the low state, I_O	12 mA
Input clamp current, I_{IK} ($V_I < 0$) (SCLOCK)	–50 mA
Output clamp current, I_{OK} ($V_O < 0$) (SDATA)	–50 mA
Package thermal impedance, θ_{JA} (see Note 2)	120 °C/W
Storage temperature range, T_{stg}	–65°C to 150°C
Lead temperature 1,6 mm (1/16 inch) from case for 10 seconds	260°C

[†] Stresses beyond those listed under “absolute maximum ratings” may cause permanent damage to the device. These are stress ratings only, and functional operation of the device at these or any other conditions beyond those indicated under “recommended operating conditions” is not implied. Exposure to absolute-maximum-rated conditions for extended periods may affect device reliability.

- NOTES: 1. The input and output negative-voltage ratings may be exceeded if the input and output clamp-current ratings are observed.
2. The package thermal impedance is calculated in accordance with EIA/JEDEC Std JESD51, except for through-hole packages, which use a trace length of zero.

recommended operating conditions (see Note 3)

		MIN	TYP	MAX	UNIT
V_{CC}	3.3-V core supply voltage	3.135		3.465	V
V_{IH}	High-level input voltage	A, OE	2	$V_{CC}+0.3$	V
		SDATA, SCLOCK (see Note 3)	2.2	5.5	V
V_{IL}	Low-level input voltage	A, OE	–0.3	0.8	V
		SDATA, SCLOCK (see Note 3)	0	1.04	V
I_{OH}	High-level output current			–24	mA
I_{OL}	Low-level output current			24	mA
R_I	Input resistance to V_{CC}		140		k Ω
$f(SCL)$	SCLOCK frequency			100	kHz
$t(BUS)$	Bus free time	4.7			μ s
$t_{su}(START)$	START setup time	4.7			μ s
$t_h(START)$	START hold time	4			μ s
$t_w(SCLL)$	SCLOCK low pulse duration	4.7			μ s
$t_w(SCLH)$	SCLOCK high pulse duration	4			μ s
$t_r(SDATA)$	SDATA input rise time			1000	ns
$t_f(SDATA)$	SDATA input fall time			300	ns
$t_{su}(SDATA)$	SDATA setup time	250			ns
$t_h(SDATA)$	SDATA hold time	0			ns
$t_{su}(STOP)$	STOP setup time	4			μ s
T_A	Operating free-air temperature	0		70	°C

NOTE 3: The CMOS-level inputs fall within these limits: $V_{IH} \text{ min} = 0.7 \times V_{CC}$ and $V_{IL} \text{ max} = 0.3 \times V_{CC}$.



electrical characteristics over recommended operating free-air temperature range (unless otherwise noted)

PARAMETER			TEST CONDITIONS	MIN	TYP	MAX	UNIT
V _{IK}	Input clamp voltage		V _{CC} = 3.135 V, I _I = -18 mA			-1.2	V
V _{OH}	High-level output voltage	Y outputs	V _{CC} = 3.135 V, I _{OH} = -1 mA	2.4			V
V _{OL}	Low-level output voltage	Y outputs	V _{CC} = 3.135 V, I _{OL} = 1 mA			0.4	V
		SDATA	V _{CC} = 3.135 V	I _{OL} = 3 mA	0.1	0.4	
				I _{OL} = 6 mA	0.2	0.6	
I _{OH}	High-level output current	SDATA	V _{CC} = 3.135 V, V _O = V _{CC} MAX			20	μA
		Y outputs	V _{CC} = 3.135 V, V _O = 2 V	-54		-126	mA
			V _{CC} = 3.3 V, V _O = 2.6 V		-60		
I _{OL}	Low-level output current	Y outputs	V _{CC} = 3.135 V, V _O = 1 V	49		118	mA
			V _{CC} = 3.3 V, V _O = 0.7 V		58		
			V _{CC} = 3.465 V, V _O = 0.4 V	23		53	
I _{IH}	High-level input current	A	V _{CC} = 3.465 V, V _I = V _{CC}			5	μA
		OE		20			
		SCLOCK, SDATA		20			
I _{IL}	Low-level input current	A	V _{CC} = 3.465 V, V _I = GND			-5	μA
		OE		-10	-50		
		SCLOCK, SDATA		-10	-50		
I _{OZ}	High-impedance-state output current		V _{CC} = 3.465 V, V _O = 3.465 V or 0			±10	μA
I _{off}	Off-state current	SCLOCK, SDATA	V _{CC} = 0 V, V _I = 0 V to 5.5 V			50	μA
I _{CC}	Supply current		V _{CC} = 3.465 V, I _O = 0		0.2	0.5	mA
ΔI _{CC}	Change in supply current		V _{CC} = 3.135 V to 3.465 V, One input at V _{CC} - 0.6 V, All other inputs at V _{CC} or GND			500	μA
C _i	Input capacitance		V _I = V _{CC} or GND, V _{CC} = 3.3 V		4		pF
C _o	Output capacitance		V _O = V _{CC} or GND, V _{CC} = 3.3 V		6		pF
C _{I/O}	SDATA I/O capacitance		V _{I/O} = V _{CC} or GND, V _{CC} = 3.3 V		7		pF

CDC319

1-LINE TO 10-LINE CLOCK DRIVER WITH I²C CONTROL INTERFACE

SCAS590A – DECEMBER 1997 – REVISED OCTOBER 2001

switching characteristics over recommended operating conditions

PARAMETER		FROM	TO	TEST CONDITIONS	MIN	MAX	UNIT
t _{PLH}	Low-to-high level propagation delay time	A	Y		1.2	3.6	ns
		SCLOCK↓	SDATA valid	V _{CC} = 3.3 V ±0.185 V, See Figure 3		2	μs
t _{PLH}	Low-to-high level propagation delay time	SDATA↑	Y	V _{CC} = 3.3 V ±0.185 V, See Figure 3		150	ns
t _{PHL}	High-to-low level propagation delay time	A	Y		1.2	3.6	ns
		SCLOCK↓	SDATA valid	V _{CC} = 3.3 V ±0.185 V, See Figure 3		2	μs
t _{PHL}	High-to-low level propagation delay time	SDATA↑	Y	V _{CC} = 3.3 V ±0.185 V, See Figure 3		150	ns
t _{PZH}	Enable time to the high level	OE	Y		1	4.7	ns
t _{PZL}	Enable time to the low level						
t _{PHZ}	Disable time from the high level						
t _{PLZ}	Disable time from the low level						
t _{sk(o)}	Skew time	A	Y			250	ps
t _{sk(p)}	Skew time	A	Y			500	ps
t _{sk(pr)}	Skew time	A	Y			1	ns
t _r	Rise time		Y		0.5	1.3	ns
t _r	Rise time (see Note 4 and Figure 3)	SDATA		C _L = 10 pF	6		ns
				C _L = 400 pF		250	
t _f	Fall time		Y		0.5	1.3	ns
t _f	Fall time (see Note 4 and Figure 3)	SDATA		C _L = 10 pF	20		ns
				C _L = 400 pF		250	
f	Operating frequency (see Note 5)			C _L = 30 pF, T _A = 70°C		100	MHz
				C _L = 20 pF, T _A = 70°C		125	
				C _L = 15 pF, T _A = 70°C		140	

NOTES: 4. This parameter has a lower limit than BUS specification. This allows use of series resistors for current spike protection.

5. See Figure 4 (Frequency versus Capacitive Load).



PARAMETER MEASUREMENT INFORMATION

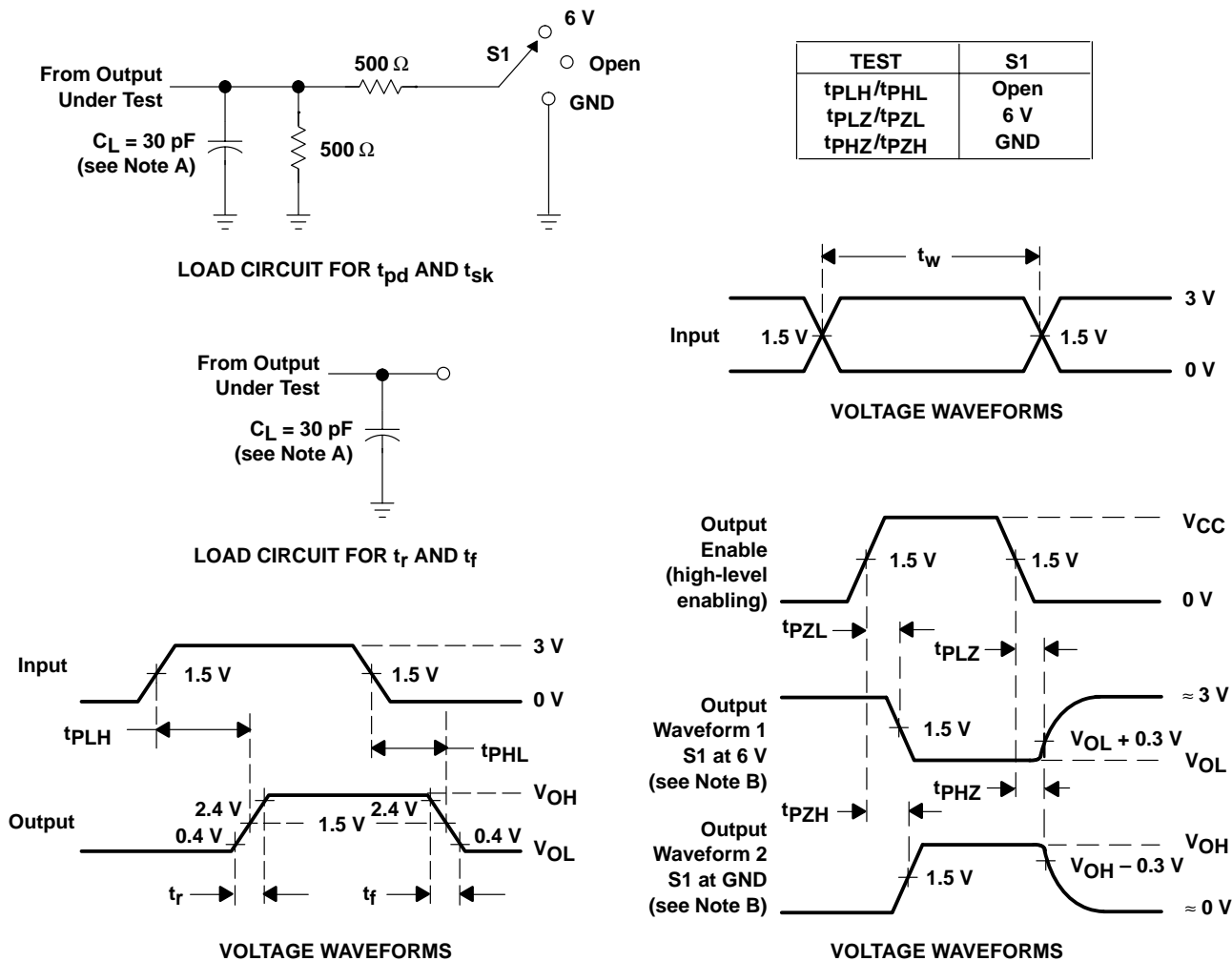

- NOTES: A. C_L includes probe and jig capacitance.
 B. Waveform 1 is for an output with internal conditions such that the output is low except when disabled by the output control. Waveform 2 is for an output with internal conditions such that the output is high except when disabled by the output control.
 C. All input pulses are supplied by generators having the following characteristics: $PRR \leq 10$ MHz, $Z_O = 50 \Omega$, $t_r \leq 2.5$ ns, $t_f \leq 2.5$ ns.
 D. The outputs are measured one at a time with one transition per measurement.

Figure 1. Load Circuit and Voltage Waveforms

CDC319
1-LINE TO 10-LINE CLOCK DRIVER
WITH I²C CONTROL INTERFACE

SCAS590A – DECEMBER 1997 – REVISED OCTOBER 2001

PARAMETER MEASUREMENT INFORMATION

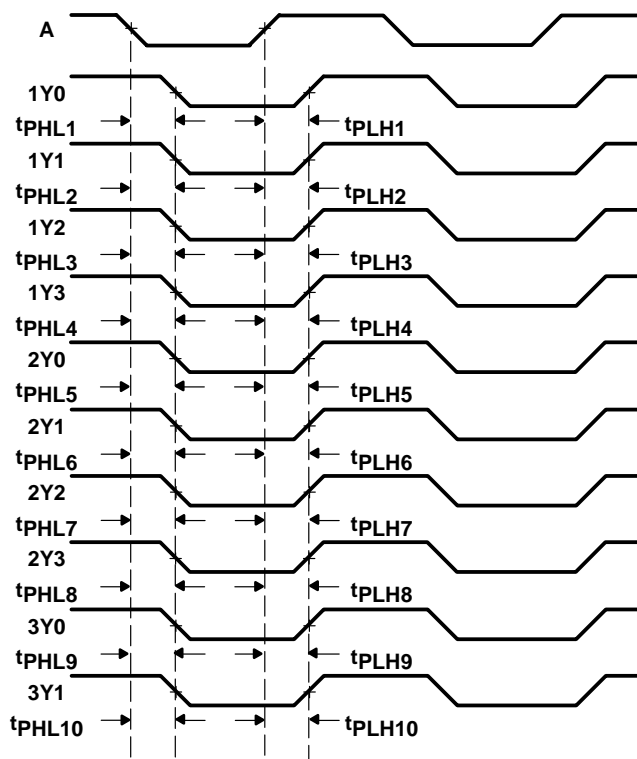

- NOTES: A. Output skew, $t_{sk(o)}$, is calculated as the greater of:
- The difference between the fastest and slowest of t_{PLHn} ($n = 1:10$)
 - The difference between the fastest and slowest of t_{PHLn} ($n = 1:10$)
- B. Pulse skew, $t_{sk(p)}$, is calculated as the greater of $|t_{PLHn} - t_{PHLn}|$ ($n = 1:10$).
- C. Process skew, $t_{sk(pr)}$, is calculated as the greater of:
- The difference between the fastest and slowest of t_{PLHn} ($n = 1:10$) across multiple devices under identical operating conditions
 - The difference between the fastest and slowest of t_{PHLn} ($n = 1:10$) across multiple devices under identical operating conditions

Figure 2. Waveforms for Calculation of $t_{sk(o)}$, $t_{sk(p)}$, $t_{sk(pr)}$

PARAMETER MEASUREMENT INFORMATION

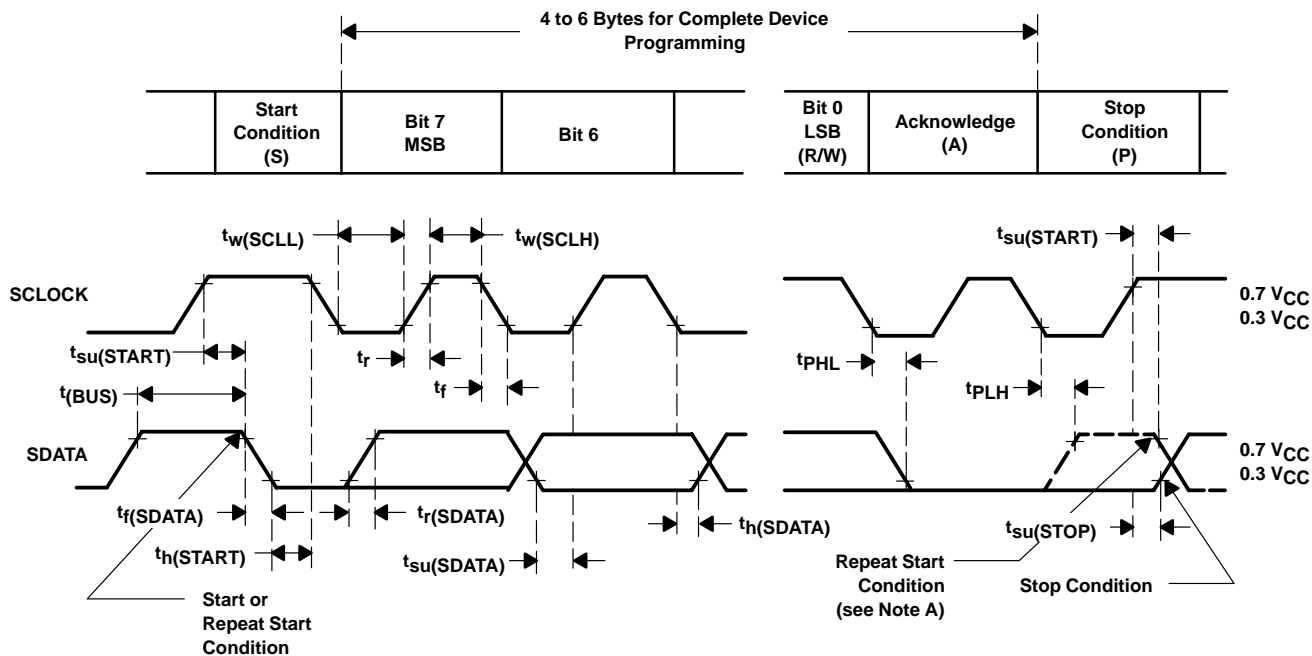
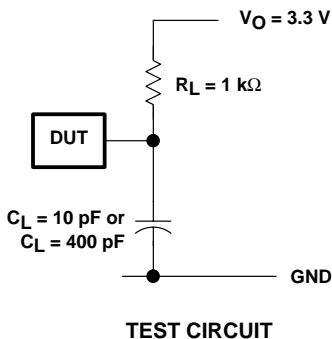

BYTE	DESCRIPTION
1	I ² C address
2	Command (dummy value, ignored)
3	Byte count (dummy value, ignored)
4	I ² C data byte 0
5	I ² C data byte 1
6	I ² C data byte 2

NOTES: A. The repeat start condition is not supported.
 B. All input pulses are supplied by generators having the following characteristics: PRR ≤ 100 kHz, Z_O = 50 Ω, t_r ≥ 10 ns, t_f ≥ 10 ns.

Figure 3. Propagation Delay Times, t_r and t_f

CDC319
1-LINE TO 10-LINE CLOCK DRIVER
WITH I²C CONTROL INTERFACE

SCAS590A – DECEMBER 1997 – REVISED OCTOBER 2001

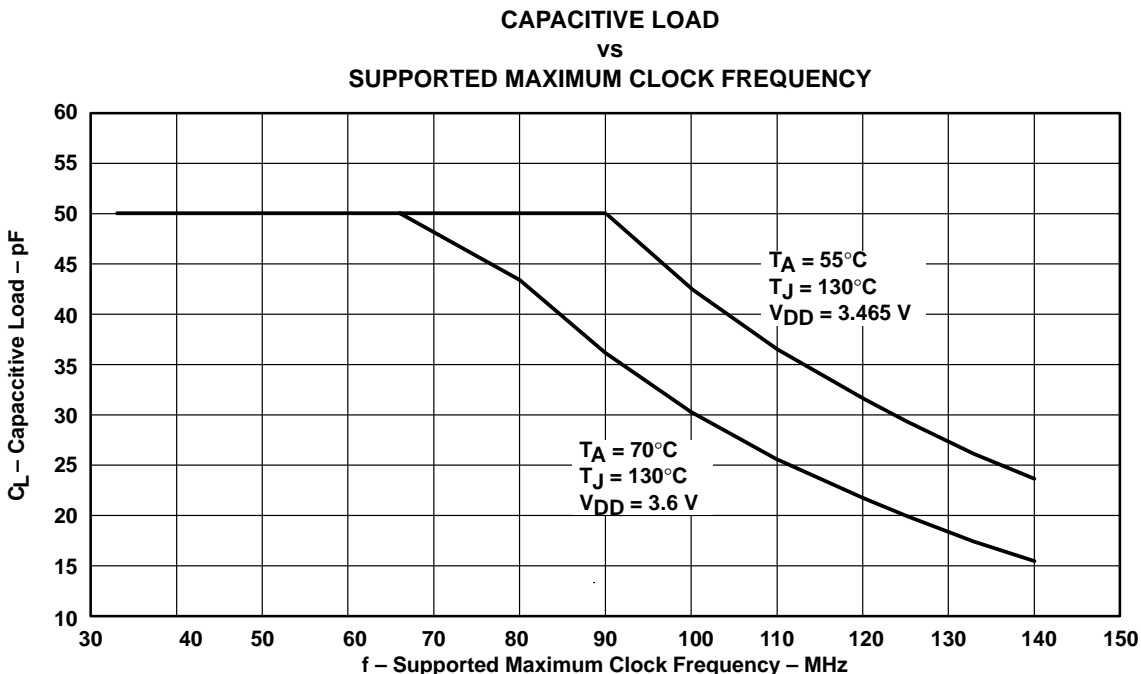

NOTES: A. With a total capacitive load of 20 pF for each output, the CDC319 is capable of running up to about 125 MHz. A lower capacitive load will allow higher application frequencies, up to 133 MHz (140 MHz).

B. CPD for the CDC319 is about 25 pF per output (21 pF if $C_L < 20$ pF)
 $P(\text{total}) = V_{DD}^2 \times CPD \times F_O \times N + (V_{OH} - V_{OL})^2 \times C_L \times F_O \times N + \text{DC load}$

where:

N = number of switching outputs

F_O = clock frequency

Package thermal impedance (junction-to-ambient) = 92.4°C/W

Maximum junction temperature = 150°C (<125°C recommended)

Figure 4

MECHANICAL INFORMATION

DB (R-PDSO-G)**

PLASTIC SMALL-OUTLINE PACKAGE

28 PIN SHOWN

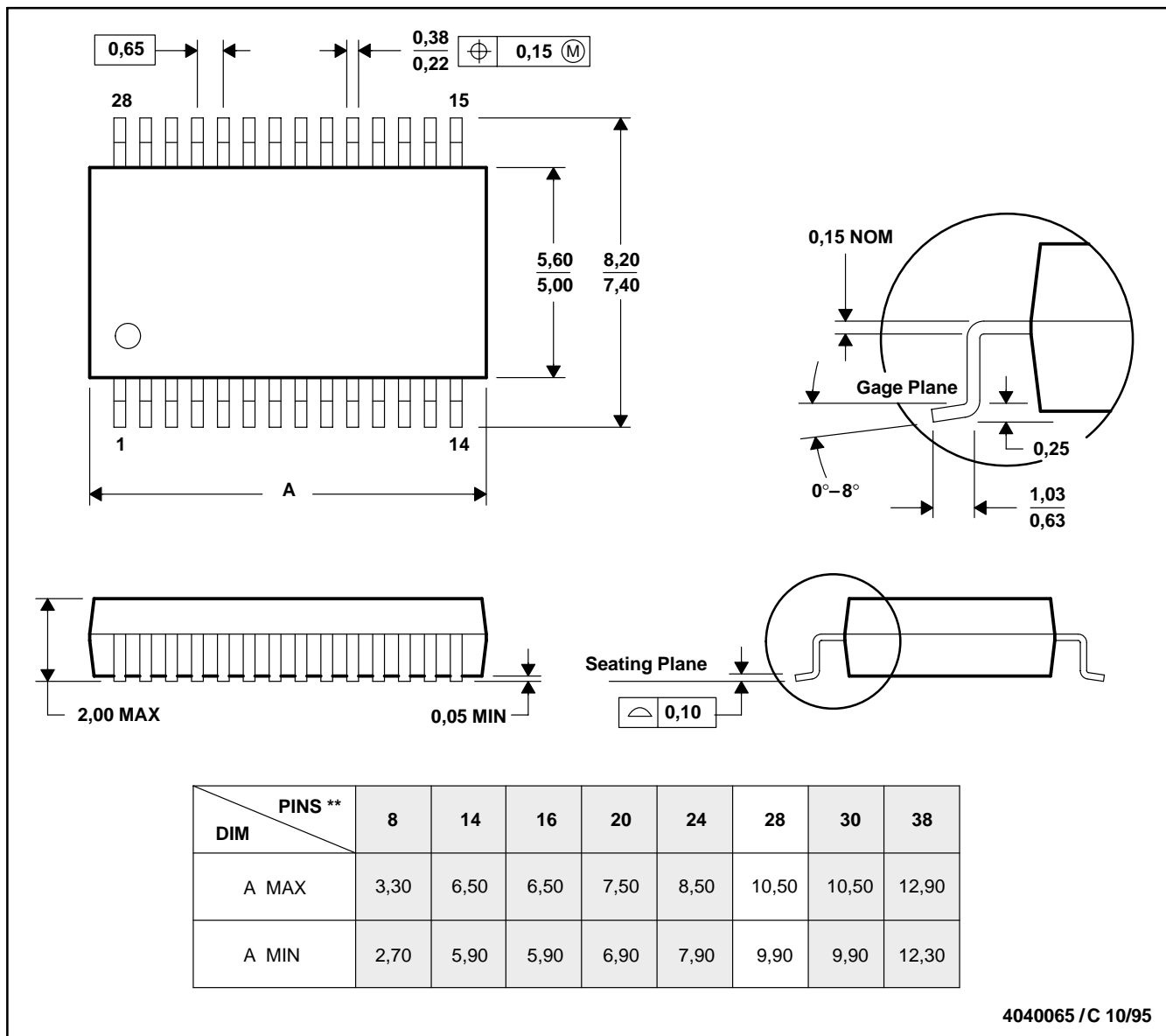

- NOTES: A. All linear dimensions are in millimeters.
 B. This drawing is subject to change without notice.
 C. Body dimensions do not include mold flash or protrusion not to exceed 0,15.
 D. Falls within JEDEC MO-150

PACKAGING INFORMATION

Orderable Device	Status ⁽¹⁾	Package Type	Package Drawing	Pins	Package Qty	Eco Plan ⁽²⁾	Lead/Ball Finish	MSL Peak Temp ⁽³⁾
CDC319DB	ACTIVE	SSOP	DB	28	50	Pb-Free (RoHS)	CU NIPDAU	Level-2-260C-1YEAR/ Level-1-220C-UNLIM
CDC319DBR	ACTIVE	SSOP	DB	28	2000	Pb-Free (RoHS)	CU NIPDAU	Level-2-260C-1YEAR/ Level-1-220C-UNLIM

⁽¹⁾ The marketing status values are defined as follows:

ACTIVE: Product device recommended for new designs.

LIFEBUY: TI has announced that the device will be discontinued, and a lifetime-buy period is in effect.

NRND: Not recommended for new designs. Device is in production to support existing customers, but TI does not recommend using this part in a new design.

PREVIEW: Device has been announced but is not in production. Samples may or may not be available.

OBsolete: TI has discontinued the production of the device.

⁽²⁾ Eco Plan - May not be currently available - please check <http://www.ti.com/productcontent> for the latest availability information and additional product content details.

None: Not yet available Lead (Pb-Free).

Pb-Free (RoHS): TI's terms "Lead-Free" or "Pb-Free" mean semiconductor products that are compatible with the current RoHS requirements for all 6 substances, including the requirement that lead not exceed 0.1% by weight in homogeneous materials. Where designed to be soldered at high temperatures, TI Pb-Free products are suitable for use in specified lead-free processes.

Green (RoHS & no Sb/Br): TI defines "Green" to mean "Pb-Free" and in addition, uses package materials that do not contain halogens, including bromine (Br) or antimony (Sb) above 0.1% of total product weight.

⁽³⁾ MSL, Peak Temp. -- The Moisture Sensitivity Level rating according to the JEDEC industry standard classifications, and peak solder temperature.

Important Information and Disclaimer: The information provided on this page represents TI's knowledge and belief as of the date that it is provided. TI bases its knowledge and belief on information provided by third parties, and makes no representation or warranty as to the accuracy of such information. Efforts are underway to better integrate information from third parties. TI has taken and continues to take reasonable steps to provide representative and accurate information but may not have conducted destructive testing or chemical analysis on incoming materials and chemicals. TI and TI suppliers consider certain information to be proprietary, and thus CAS numbers and other limited information may not be available for release.

In no event shall TI's liability arising out of such information exceed the total purchase price of the TI part(s) at issue in this document sold by TI to Customer on an annual basis.

IMPORTANT NOTICE

Texas Instruments Incorporated and its subsidiaries (TI) reserve the right to make corrections, modifications, enhancements, improvements, and other changes to its products and services at any time and to discontinue any product or service without notice. Customers should obtain the latest relevant information before placing orders and should verify that such information is current and complete. All products are sold subject to TI's terms and conditions of sale supplied at the time of order acknowledgment.

TI warrants performance of its hardware products to the specifications applicable at the time of sale in accordance with TI's standard warranty. Testing and other quality control techniques are used to the extent TI deems necessary to support this warranty. Except where mandated by government requirements, testing of all parameters of each product is not necessarily performed.

TI assumes no liability for applications assistance or customer product design. Customers are responsible for their products and applications using TI components. To minimize the risks associated with customer products and applications, customers should provide adequate design and operating safeguards.

TI does not warrant or represent that any license, either express or implied, is granted under any TI patent right, copyright, mask work right, or other TI intellectual property right relating to any combination, machine, or process in which TI products or services are used. Information published by TI regarding third-party products or services does not constitute a license from TI to use such products or services or a warranty or endorsement thereof. Use of such information may require a license from a third party under the patents or other intellectual property of the third party, or a license from TI under the patents or other intellectual property of TI.

Reproduction of information in TI data books or data sheets is permissible only if reproduction is without alteration and is accompanied by all associated warranties, conditions, limitations, and notices. Reproduction of this information with alteration is an unfair and deceptive business practice. TI is not responsible or liable for such altered documentation.

Resale of TI products or services with statements different from or beyond the parameters stated by TI for that product or service voids all express and any implied warranties for the associated TI product or service and is an unfair and deceptive business practice. TI is not responsible or liable for any such statements.

Following are URLs where you can obtain information on other Texas Instruments products and application solutions:

Products		Applications	
Amplifiers	amplifier.ti.com	Audio	www.ti.com/audio
Data Converters	dataconverter.ti.com	Automotive	www.ti.com/automotive
DSP	dsp.ti.com	Broadband	www.ti.com/broadband
Interface	interface.ti.com	Digital Control	www.ti.com/digitalcontrol
Logic	logic.ti.com	Military	www.ti.com/military
Power Mgmt	power.ti.com	Optical Networking	www.ti.com/opticalnetwork
Microcontrollers	microcontroller.ti.com	Security	www.ti.com/security
		Telephony	www.ti.com/telephony
		Video & Imaging	www.ti.com/video
		Wireless	www.ti.com/wireless

Mailing Address: Texas Instruments
Post Office Box 655303 Dallas, Texas 75265