

CDCV857

2.5-V PHASE LOCK LOOP CLOCK DRIVER

SCAS645A – AUGUST 2000 – REVISED OCTOBER 2000

- Phase-Lock Loop Clock Driver for Double Data-Rate Synchronous DRAM Applications
- Spread Spectrum Clock Compatible
- Operating Frequency: 60 to 200 MHz
- Low Jitter (cyc–cyc): ± 75 ps
- Distributes One Differential Clock Input to Ten Differential Outputs
- Three-State Outputs When the Input Differential Clocks Are < 20 MHz
- Operates From Dual 2.5-V Supplies
- 48-Pin TSSOP Package
- Consumes < 200 - μ A Quiescent Current
- External Feedback PIN ($\overline{\text{FBIN}}$, $\overline{\text{FBIN}}$) Are Used to Synchronize the Outputs to the Input Clocks

description

The CDCV857 is a high-performance, low-skew, low-jitter zero delay buffer that distributes a differential clock input pair (CLK, $\overline{\text{CLK}}$) to ten differential pairs of clock outputs (Y[0:9], $\overline{\text{Y}}[0:9]$) and one differential pair of feedback clock output (FBOUT, $\overline{\text{FBOUT}}$). The clock outputs are controlled by the clock inputs (CLK, $\overline{\text{CLK}}$), the feedback clocks (FBIN, $\overline{\text{FBIN}}$), and the analog power input (AV_{DD}). When $\overline{\text{PWRDWN}}$ is high, the outputs switch in phase and frequency with CLK. When $\overline{\text{PWRDWN}}$ is low, all outputs are disabled to high impedance state (3-state), and the PLL is shut down (low power mode). The device also enters this low power mode when the input frequency falls below a suggested detection frequency that is below 20 MHz (typical 10 MHz). An input frequency detection circuit will detect the low frequency condition and after applying a > 20 MHz input signal this detection circuit turns on the PLL again and enables the outputs.

When AV_{DD} is strapped low, the PLL is turned off and bypassed for test purposes. The CDCV857 is also able to track spread spectrum clocking for reduced EMI.

Since the CDCV857 is based on PLL circuitry, it requires a stabilization time to achieve phase-lock of the PLL. This stabilization time is required following power up. The CDCV857 is characterized for operation from 0°C to 85°C .

**DGG PACKAGE
(TOP VIEW)**

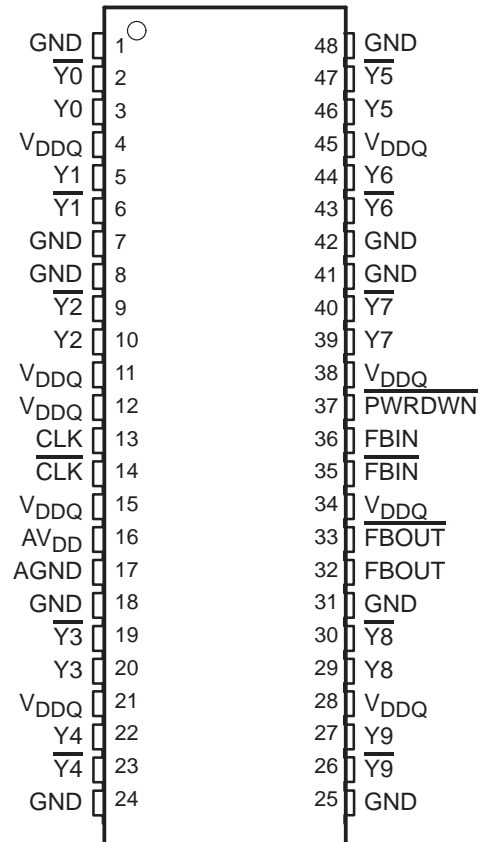

Please be aware that an important notice concerning availability, standard warranty, and use in critical applications of Texas Instruments semiconductor products and disclaimers thereto appears at the end of this data sheet.

PRODUCTION DATA information is current as of publication date. Products conform to specifications per the terms of Texas Instruments standard warranty. Production processing does not necessarily include testing of all parameters.



POST OFFICE BOX 655303 • DALLAS, TEXAS 75265

Copyright © 2000, Texas Instruments Incorporated

Terminal Functions

TERMINAL NAME	NO.	I/O	DESCRIPTION
AGND	17		Ground for 2.5-V analog supply
AV _{DD}	16		2.5-V Analog supply
CLK, $\overline{\text{CLK}}$	13, 14	I	Differential clock input
$\overline{\text{FBIN}}$, FBIN	35, 36	I	Feedback differential clock input
F $\overline{\text{BOUT}}$, F $\overline{\text{BOUT}}$	32, 33	O	Feedback differential clock output
GND	1, 7, 8, 18, 24, 25, 31, 41, 42, 48		Ground
$\overline{\text{PWRDWN}}$	37	I	Output enable for Y and $\overline{\text{Y}}$
V _{DDQ}	4, 11, 12, 15, 21, 28, 34, 38, 45		2.5-V Supply
Y[0:9]	3, 5, 10, 20, 22, 27, 29, 39, 44, 46	O	Buffered output copies of input clock, CLK
$\overline{\text{Y}}$ [0:9]	2, 6, 9, 19, 23, 26, 30, 40, 43, 47	O	Buffered output copies of input clock, $\overline{\text{CLK}}$

absolute maximum ratings over operating free-air temperature (unless otherwise noted)[†]

Supply voltage range, V _{DDQ} , AV _{DD}	0.5 V to 3.6 V
Input voltage range, V _I (see Notes 1 and 2)	–0.5 V to V _{DDQ} 0.5 V
Output voltage range, V _O (see Notes 1 and 2)	–0.5 V to V _{DDQ} 0.5 V
Input clamp current, I _{IK} (V _I < 0 or V _I > V _{DDQ})	±50 mA
Output clamp current, I _{OK} (V _O < 0 or V _O > V _{DDQ})	±50 mA
Continuous output current, I _O (V _O = 0 to V _{DDQ})	±50 mA
Continuous current to GND or V _{DDQ}	±100 mA
Package thermal impedance, θ_{JA} (see Note 3): DGG package	89°C/W
Storage temperature range T _{stg}	–65°C to 150°C

[†] Stresses beyond those listed under “absolute maximum ratings” may cause permanent damage to the device. These are stress ratings only, and functional operation of the device at these or any other conditions beyond those indicated under “recommended operating conditions” is not implied. Exposure to absolute-maximum-rated conditions for extended periods may affect device reliability.

- NOTES:
1. The input and output negative voltage ratings may be exceeded if the input and output clamp-current ratings are observed.
 2. This value is limited to 3.6 V maximum.
 3. The package thermal impedance is calculated in accordance with JESD 51.

CDCV857

2.5-V PHASE LOCK LOOP CLOCK DRIVER

SCAS645A – AUGUST 2000 – REVISED OCTOBER 2000

recommended operating conditions (see Note 4)

		MIN	TYP	MAX	UNIT
Supply voltage, V_{DDQ} , AV_{DD}		2.3		2.7	V
Low level input voltage, V_{IL}	CLK, $\overline{\text{CLK}}$, FBIN, $\overline{\text{FBIN}}$			$V_{DDQ}/2 - 0.18$	V
	PWRDWN	-0.3		0.7	
High level input voltage, V_{IH}	CLK, $\overline{\text{CLK}}$, FBIN, $\overline{\text{FBIN}}$	$V_{DDQ}/2 + 0.18$			V
	PWRDWN	1.7		$V_{DDQ} + 0.3$	
DC input signal voltage (see Note 5)		-0.3		V_{DDQ}	V
Differential input signal voltage, V_{ID} (see Note 6)	DC CLK, FBIN	0.36		$V_{DDQ} + 0.6$	V
	AC CLK, FBIN	0.7		$V_{DDQ} + 0.6$	
Output differential cross-voltage, V_{OX} (see Note 7)		$V_{DDQ}/2 - 0.2$	$V_{DDQ}/2$	$V_{DDQ}/2 + 0.2$	V
Input differential pair cross-voltage, V_{IX} (see Note 7)		$V_{DDQ}/2 - 0.2$		$V_{DDQ}/2 + 0.2$	V
High-level output current, I_{OH}				-12	mA
Low-level output current, I_{OL}				12	mA
Input slew rate, SR		1		4	V/ns
Operating free-air temperature, T_A		0		85	°C

- NOTES:
4. Unused inputs must be held high or low to prevent them from floating.
 5. DC input signal voltage specifies the allowable dc execution of differential input.
 6. Differential input signal voltage specifies the differential voltage $|V_{TR} - V_{CP}|$ required for switching, where V_{TR} is the true input level and V_{CP} is the complementary input level.
 7. Differential cross-point voltage is expected to track variations of V_{CC} and is the voltage at which the differential signals must be crossing.



CDCV857

2.5-V PHASE LOCK LOOP CLOCK DRIVER

SCAS645A – AUGUST 2000 – REVISED OCTOBER 2000

electrical characteristics over recommended operating free-air temperature range (unless otherwise noted)

PARAMETER			TEST CONDITIONS	MIN	TYP†	MAX	UNIT
V _{IK}	Input voltage	All inputs	V _{DDQ} = 2.3 V, I _I = -18 mA			-1.2	V
V _{OH}	High-level output voltage		V _{DDQ} = min to max, I _{OH} = -1 mA	V _{DDQ} - 0.1			V
			V _{DDQ} = 2.3 V, I _{OH} = -12 mA	1.7			
V _{OL}	Low-level output voltage		V _{DDQ} = min to max, I _{OL} = 1 mA			0.1	V
			V _{DDQ} = 2.3 V, I _{OL} = 12 mA			0.6	
I _{OH}	High-level output current		V _{DDQ} = 2.3 V, V _O = 1 V	-18	-32		mA
I _{OL}	Low-level output current		V _{DDQ} = 2.3 V, V _O = 1.2 V	26	35		mA
V _O	Output voltage swing		Differential outputs are terminated with 120 Ω	1.1		V _{DDQ} - 0.4	V
V _{OX}	Output differential cross-voltage§			V _{DDQ} /2 - 0.2	V _{DDQ} /2	V _{DDQ} /2 + 0.2	
I _I	Input current		V _{DDQ} = 2.7 V, V _I = 0 V to 2.7 V			±10	μA
I _{OZ}	High-impedance-state output current		V _{DDQ} = 2.7 V, V _O = V _{DDQ} or GND			±10	μA
I _{DDPD}	Power down current on V _{DDQ} + AV _{DD}		CLK and $\overline{\text{CLK}}$ = 0 MHz; $\overline{\text{PWRDWN}}$ = Low; Σ of I _{DD} and A _I DD		100	200	μA
I _{DD}	Dynamic current on V _{DDQ}	all outputs loaded as shown in Figure 3	f _O = 200 MHz		275	330	mA
			f _O = 167 MHz		250	300	
A _I DD	Supply current on AV _{DD}		f _O = 200 MHz		10	12	mA
			f _O = 167 MHz		8	10	
C _I	Input capacitance		V _{CC} = 2.5 V, V _I = V _{CC} or GND	2	2.5	3	pF
C _O	Output capacitance		V _{CC} = 2.5 V, V _O = V _{CC} or GND	2.5	3	3.5	pF

† All typical values are at respective nominal V_{DDQ}.

‡ The value of V_{OC} is expected to be |V_{TR} + V_{CPI}|/2. In case of each clock directly terminated by a 120-Ω resistor, where V_{TR} is the true input signal voltage and V_{CPI} is the complementary input signal voltage.

§ Differential cross-point voltage is expected to track variations of V_{DDQ} and is the voltage at which the differential signals must be crossing.

timing requirements over recommended ranges of supply voltage and operating free-air temperature

		MIN	MAX	UNIT
f _{CK}	Operating clock frequency	60	200	MHz
	Application clock frequency			
Input clock duty cycle		40%	60%	
Stabilization time¶ (PLL mode)			10	μs
Stabilization time¶ (Bypass mode)			30	ns

¶ Time required for the integrated PLL circuit to obtain phase lock of its feedback signal to its reference signal. For phase lock to be obtained, a fixed-frequency, fixed-phase reference signal must be present at CLK. Until phase lock is obtained, the specifications for propagation delay, skew, and jitter parameters given in the switching characteristics table are not applicable. This parameter does not apply for input modulation under SSC application.



CDCV857

2.5-V PHASE LOCK LOOP CLOCK DRIVER

SCAS645A – AUGUST 2000 – REVISED OCTOBER 2000

switching characteristics

PARAMETER		TEST CONDITIONS	MIN	TYP [†]	MAX	UNIT	
t_{PLH}^{\ddagger}	Low to high level propagation delay time	Test mode/CLK to any output		4.5		ns	
t_{PHL}^{\ddagger}	High-to low level propagation delay time	Test mode/CLK to any output		4.5		ns	
$t_{jit(per)}^{\S}$	Jitter (period), See Figure 6	66 MHz	-90		90	ps	
		100/133/167/200 MHz	-75		75	ps	
$t_{jit(cc)}^{\S}$	Jitter (cycle-to-cycle), See Figure 3	66 MHz	-180		180	ps	
		100/133/167/200 MHz	-75		75	ps	
$t_{jit(hper)}^{\S}$	Half-period jitter, See Figure 7	66 MHz	-160		160	ps	
		100/133/167/200 MHz	-100		100	ps	
$t_{slr(i)}$	Input clock slew rate, See Figure 8		1		4	V/ns	
$t_{slr(o)}$	Output clock slew rate, See Figure 8		1		2	V/ns	
$t_{d(\emptyset)}^{\S}$	Dynamic phase offset (this includes jitter), See Figure 4(b)	SSC off	66 MHz	-180		180	ps
			100/133 MHz	-130		130	
			167/200 MHz	-90		90	
		SSC on	66 MHz	-230		230	
			100/133 MHz	-170		170	
			167/200 MHz	-100		100	
$t_{(\emptyset)}$	Static phase offset, See Figure 4(a)	66/100/133/167 MHz	-100		100	ps	
		200 MHz	-150		50	ps	
$tsk(o)^{\parallel}$	Output skew, See Figure 5				75	ps	
t_r, t_f	Output rise and fall times (20% – 80%)	Load: 120 Ω /14 pF	650		900	ps	

[†] All typical values are at a respective nominal V_{DDQ} .

[‡] Refers to transition of noninverting output.

[§] This parameter is assured by design but can not be 100% production tested.

^{||} All differential output pins are terminated with 120 Ω /14 pF.

PARAMETER MEASUREMENT INFORMATION

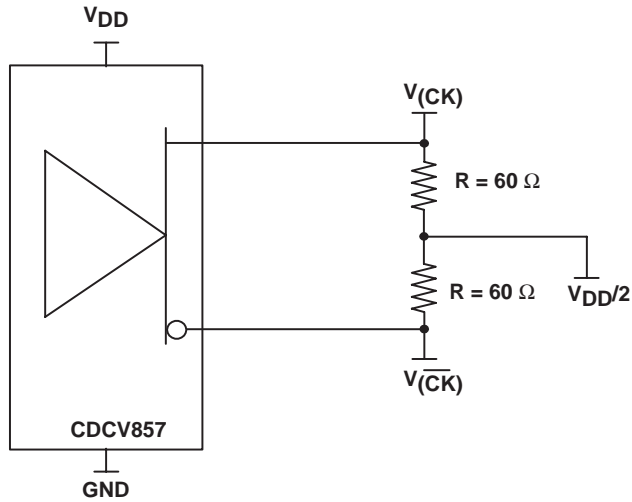
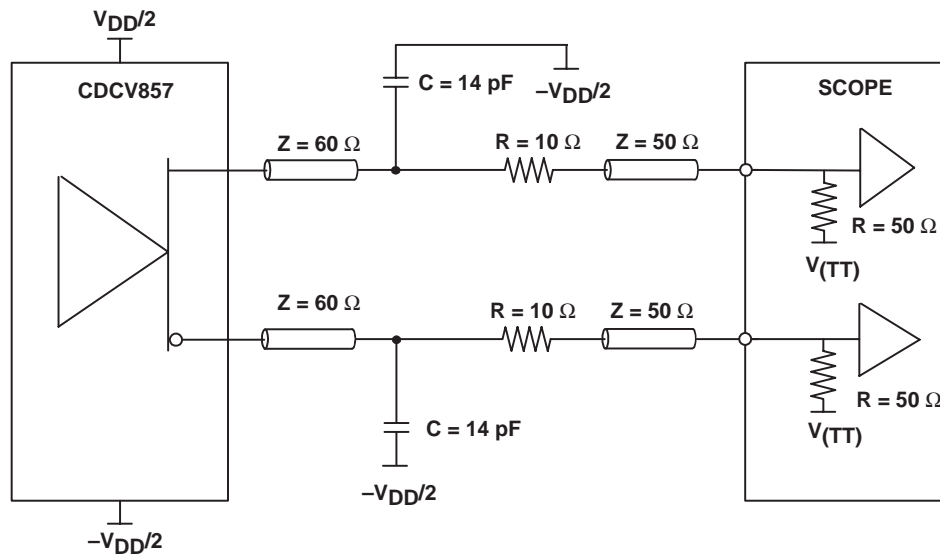

Figure 1. IBIS Model Output Load (used for slew rate measurement)



NOTE: $V_{(TT)} = \text{GND}$

Figure 2. Output Load Test Circuit

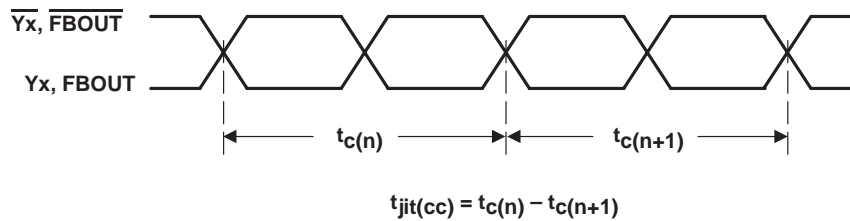
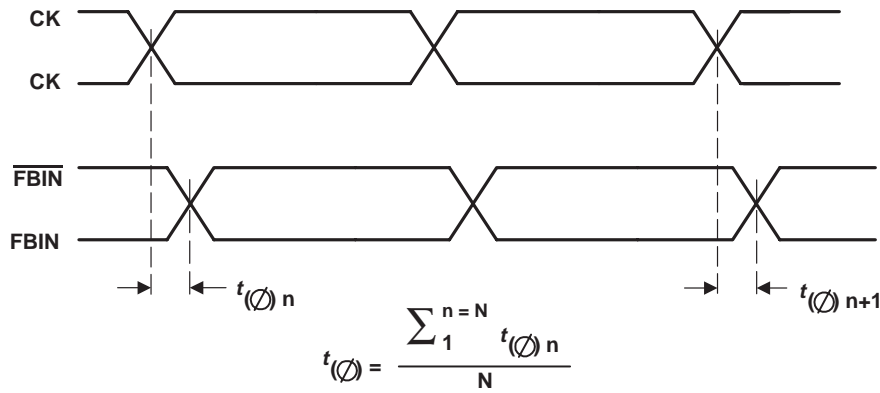

Figure 3. Cycle-to-Cycle Jitter

CDCV857 2.5-V PHASE LOCK LOOP CLOCK DRIVER

SCAS645A – AUGUST 2000 – REVISED OCTOBER 2000

PARAMETER MEASUREMENT INFORMATION



(N is a large number of samples)

(a) Static Phase Offset

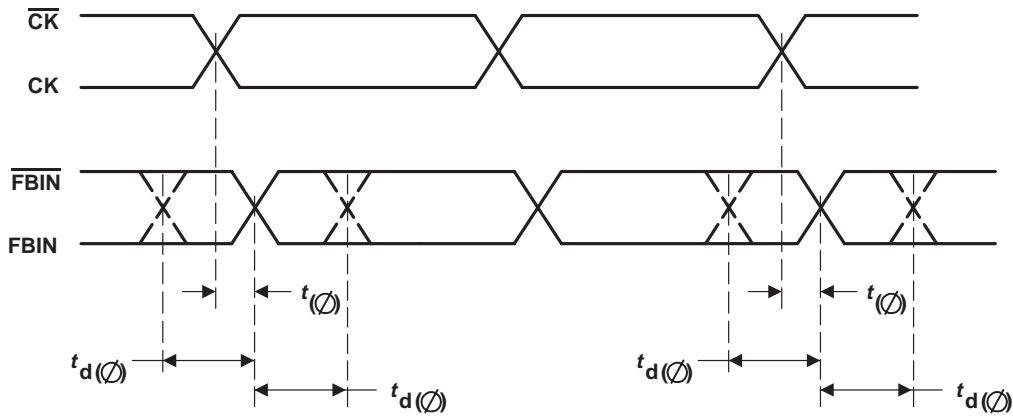

(b) Dynamic Phase Offset

Figure 4. Phase Offset

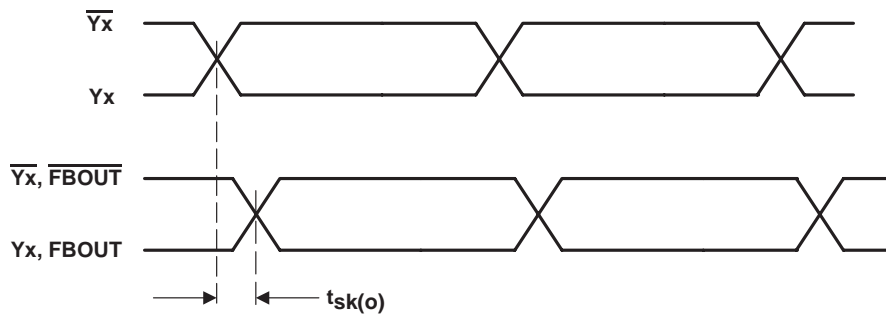

Figure 5. Output Skew

PARAMETER MEASUREMENT INFORMATION

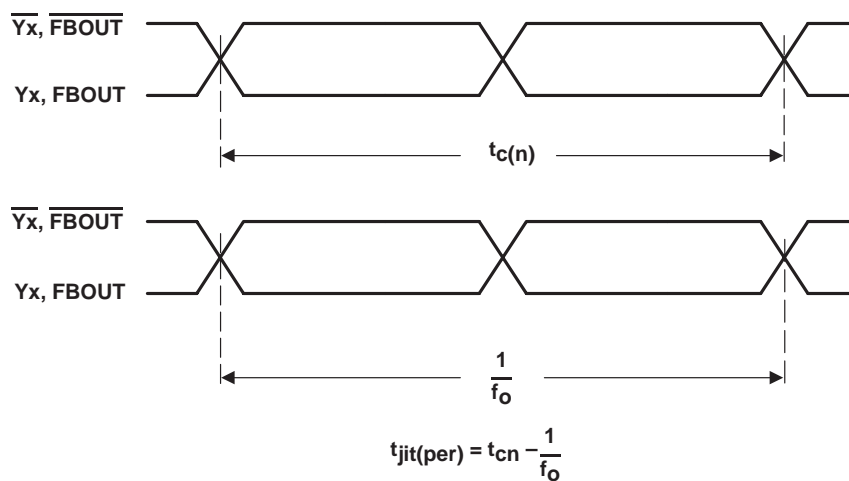

Figure 6. Period Jitter

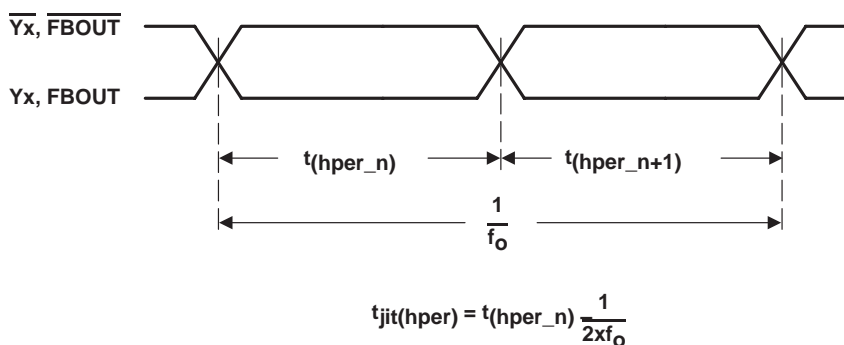

Figure 7. Half-Period Jitter

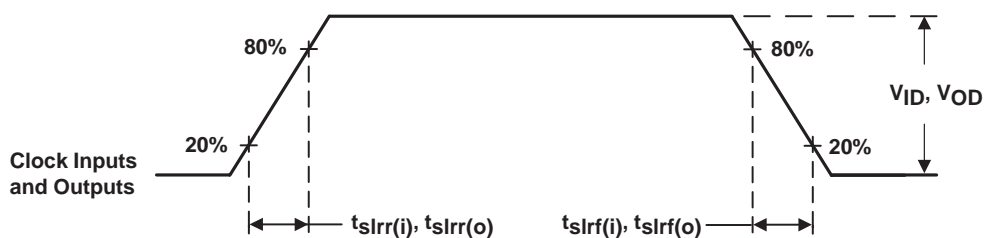

Figure 8. Input and Output Slew Rates

CDCV857 2.5-V PHASE LOCK LOOP CLOCK DRIVER

SCAS645A – AUGUST 2000 – REVISED OCTOBER 2000

MECHANICAL DATA

DGG (R-PDSO-G**)

PLASTIC SMALL-OUTLINE PACKAGE

48 PINS SHOWN

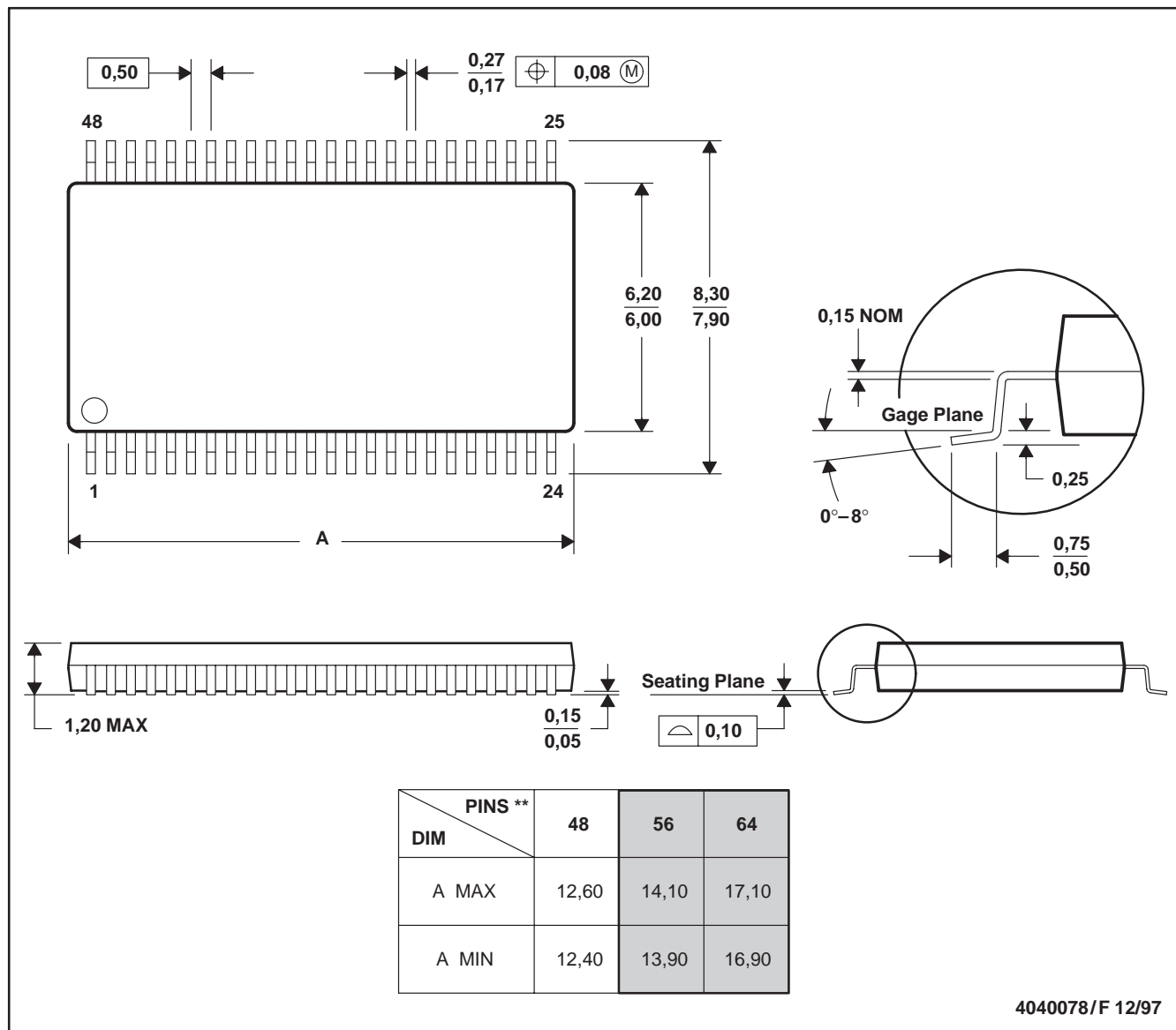

- NOTES: A. All linear dimensions are in millimeters.
 B. This drawing is subject to change without notice.
 C. Body dimensions do not include mold protrusion not to exceed 0,15.
 D. Falls within JEDEC MO-153

PACKAGING INFORMATION

Orderable Device	Status ⁽¹⁾	Package Type	Package Drawing	Pins	Package Qty	Eco Plan ⁽²⁾	Lead/Ball Finish	MSL Peak Temp ⁽³⁾
CDCV857DGG	ACTIVE	TSSOP	DGG	48	40	Pb-Free (RoHS)	CU NIPDAU	Level-1-250C-UNLIM
CDCV857DGGR	ACTIVE	TSSOP	DGG	48	2000	Pb-Free (RoHS)	CU NIPDAU	Level-1-250C-UNLIM
CDCV857DGGRG4	PREVIEW	TSSOP	DGG	48	2000	None	Call TI	Call TI

⁽¹⁾ The marketing status values are defined as follows:

ACTIVE: Product device recommended for new designs.

LIFEBUY: TI has announced that the device will be discontinued, and a lifetime-buy period is in effect.

NRND: Not recommended for new designs. Device is in production to support existing customers, but TI does not recommend using this part in a new design.

PREVIEW: Device has been announced but is not in production. Samples may or may not be available.

OBSOLETE: TI has discontinued the production of the device.

⁽²⁾ Eco Plan - May not be currently available - please check <http://www.ti.com/productcontent> for the latest availability information and additional product content details.

None: Not yet available Lead (Pb-Free).

Pb-Free (RoHS): TI's terms "Lead-Free" or "Pb-Free" mean semiconductor products that are compatible with the current RoHS requirements for all 6 substances, including the requirement that lead not exceed 0.1% by weight in homogeneous materials. Where designed to be soldered at high temperatures, TI Pb-Free products are suitable for use in specified lead-free processes.

Green (RoHS & no Sb/Br): TI defines "Green" to mean "Pb-Free" and in addition, uses package materials that do not contain halogens, including bromine (Br) or antimony (Sb) above 0.1% of total product weight.

⁽³⁾ MSL, Peak Temp. -- The Moisture Sensitivity Level rating according to the JEDEC industry standard classifications, and peak solder temperature.

Important Information and Disclaimer: The information provided on this page represents TI's knowledge and belief as of the date that it is provided. TI bases its knowledge and belief on information provided by third parties, and makes no representation or warranty as to the accuracy of such information. Efforts are underway to better integrate information from third parties. TI has taken and continues to take reasonable steps to provide representative and accurate information but may not have conducted destructive testing or chemical analysis on incoming materials and chemicals. TI and TI suppliers consider certain information to be proprietary, and thus CAS numbers and other limited information may not be available for release.

In no event shall TI's liability arising out of such information exceed the total purchase price of the TI part(s) at issue in this document sold by TI to Customer on an annual basis.

IMPORTANT NOTICE

Texas Instruments Incorporated and its subsidiaries (TI) reserve the right to make corrections, modifications, enhancements, improvements, and other changes to its products and services at any time and to discontinue any product or service without notice. Customers should obtain the latest relevant information before placing orders and should verify that such information is current and complete. All products are sold subject to TI's terms and conditions of sale supplied at the time of order acknowledgment.

TI warrants performance of its hardware products to the specifications applicable at the time of sale in accordance with TI's standard warranty. Testing and other quality control techniques are used to the extent TI deems necessary to support this warranty. Except where mandated by government requirements, testing of all parameters of each product is not necessarily performed.

TI assumes no liability for applications assistance or customer product design. Customers are responsible for their products and applications using TI components. To minimize the risks associated with customer products and applications, customers should provide adequate design and operating safeguards.

TI does not warrant or represent that any license, either express or implied, is granted under any TI patent right, copyright, mask work right, or other TI intellectual property right relating to any combination, machine, or process in which TI products or services are used. Information published by TI regarding third-party products or services does not constitute a license from TI to use such products or services or a warranty or endorsement thereof. Use of such information may require a license from a third party under the patents or other intellectual property of the third party, or a license from TI under the patents or other intellectual property of TI.

Reproduction of information in TI data books or data sheets is permissible only if reproduction is without alteration and is accompanied by all associated warranties, conditions, limitations, and notices. Reproduction of this information with alteration is an unfair and deceptive business practice. TI is not responsible or liable for such altered documentation.

Resale of TI products or services with statements different from or beyond the parameters stated by TI for that product or service voids all express and any implied warranties for the associated TI product or service and is an unfair and deceptive business practice. TI is not responsible or liable for any such statements.

Following are URLs where you can obtain information on other Texas Instruments products and application solutions:

Products		Applications	
Amplifiers	amplifier.ti.com	Audio	www.ti.com/audio
Data Converters	dataconverter.ti.com	Automotive	www.ti.com/automotive
DSP	dsp.ti.com	Broadband	www.ti.com/broadband
Interface	interface.ti.com	Digital Control	www.ti.com/digitalcontrol
Logic	logic.ti.com	Military	www.ti.com/military
Power Mgmt	power.ti.com	Optical Networking	www.ti.com/opticalnetwork
Microcontrollers	microcontroller.ti.com	Security	www.ti.com/security
		Telephony	www.ti.com/telephony
		Video & Imaging	www.ti.com/video
		Wireless	www.ti.com/wireless

Mailing Address: Texas Instruments
Post Office Box 655303 Dallas, Texas 75265