

CY74FCT2541T

8-BIT BUFFER/LINE DRIVER WITH 3-STATE OUTPUTS

SCCS041B – SEPTEMBER 1994 – REVISED SEPTEMBER 2001

- Function and Pinout Compatible With FCT and F Logic
- 25-Ω Output Series Resistors to Reduce Transmission-Line Reflection Noise
- Reduced V_{OH} (Typically = 3.3 V) Versions of Equivalent FCT Functions
- Edge-Rate Control Circuitry for Significantly Improved Noise Characteristics
- I_{off} Supports Partial-Power-Down Mode Operation
- ESD Protection Exceeds JESD 22
 - 2000-V Human-Body Model (A114-A)
 - 200-V Machine Model (A115-A)
 - 1000-V Charged-Device Model (C101)
- Matched Rise and Fall Times
- Fully Compatible With TTL Input and Output Logic Levels
- 12-mA Output Sink Current
15-mA Output Source Current
- 3-State Outputs

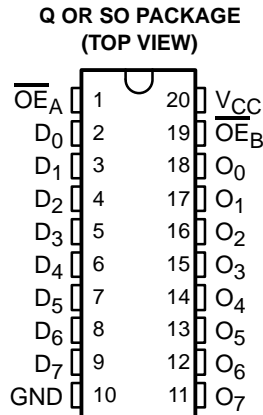

description

The CY74FCT2541T is an octal buffer and line driver designed to be employed as a memory-address driver, clock driver, and bus-oriented transmitter/receiver. On-chip termination resistors at the outputs reduce system noise caused by reflections. The CY74FCT2541T can replace the CY74FCT541T to reduce noise in an existing design. The speed of the CY74FCT2541T is comparable to bipolar logic counterparts, while reducing power dissipation. Input and output voltage levels allow direct interface with TTL and CMOS devices without external components.

This device is fully specified for partial-power-down applications using I_{off} . The I_{off} circuitry disables the outputs, preventing damaging current backflow through the device when it is powered down.

ORDERING INFORMATION

TA	PACKAGE†		SPEED (ns)	ORDERABLE PART NUMBER	TOP-SIDE MARKING
-40°C to 85°C	QSOP – Q	Tape and reel	4.1	CY74FCT2541CTQCT	FCT2541C
	SOIC – SO	Tube	4.1	CY74FCT2541CTSOC	FCT2541C
		Tape and reel	4.1	CY74FCT2541CTSOCT	
	QSOP – Q	Tape and reel	4.8	CY74FCT2541ATQCT	FCT2541A
	SOIC – SO	Tube	4.8	CY74FCT2541ATSOC	FCT2541A
		Tape and reel	4.8	CY74FCT2541ATSOCT	
	QSOP – Q	Tape and reel	8	CY74FCT2541TQCT	FCT2541
	SOIC – SO	Tube	8	CY74FCT2541TSOC	FCT2541
Tape and reel		8	CY74FCT2541TSOCT		

† Package drawings, standard packing quantities, thermal data, symbolization, and PCB design guidelines are available at www.ti.com/sc/package.



Please be aware that an important notice concerning availability, standard warranty, and use in critical applications of Texas Instruments semiconductor products and disclaimers thereto appears at the end of this data sheet.

PRODUCTION DATA information is current as of publication date. Products conform to specifications per the terms of Texas Instruments standard warranty. Production processing does not necessarily include testing of all parameters.

 **TEXAS
INSTRUMENTS**

POST OFFICE BOX 655303 • DALLAS, TEXAS 75265

Copyright © 2001, Texas Instruments Incorporated

CY74FCT2541T

8-BIT BUFFER/LINE DRIVER

WITH 3-STATE OUTPUTS

SCCS041B – SEPTEMBER 1994 – REVISED SEPTEMBER 2001

FUNCTION TABLE

INPUTS			OUTPUT
\overline{OE}_A	\overline{OE}_B	D	
L	L	L	L
L	L	H	H
H	H	X	Z

H = High logic level, L = Low logic level,
X = Don't care, Z = High-impedance state

logic diagram (positive logic)

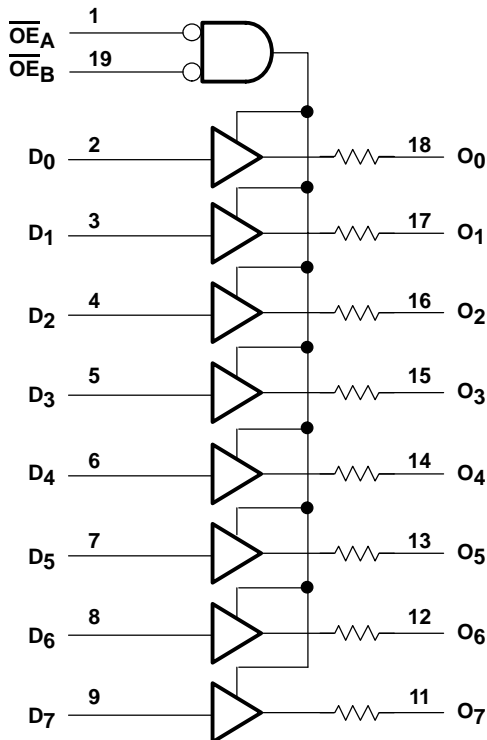

absolute maximum rating over operating free-air temperature range (unless otherwise noted)†

Supply voltage range to ground potential	–0.5 V to 7 V
DC input voltage range	–0.5 V to 7 V
DC output voltage range	–0.5 V to 7 V
DC output current (maximum sink current/pin)	120 mA
Package thermal impedance, θ_{JA} (see Note 1): Q package	68°C/W
SO package	58°C/W
Ambient temperature range with power applied, T_A	–65°C to 135°C
Storage temperature range, T_{stg}	–65°C to 150°C

† Stresses beyond those listed under “absolute maximum ratings” may cause permanent damage to the device. These are stress ratings only, and functional operation of the device at these or any other conditions beyond those indicated under “recommended operating conditions” is not implied. Exposure to absolute-maximum-rated conditions for extended periods may affect device reliability.

NOTE 1: The package thermal impedance is calculated in accordance with JESD 51-7.



POST OFFICE BOX 655303 • DALLAS, TEXAS 75265

CY74FCT2541T
8-BIT BUFFER/LINE DRIVER
WITH 3-STATE OUTPUTS

SCCS041B – SEPTEMBER 1994 – REVISED SEPTEMBER 2001

recommended operating conditions (see Note 2)

		MIN	NOM	MAX	UNIT
V_{CC}	Supply voltage	4.75	5	5.25	V
V_{IH}	High-level input voltage	2			V
V_{IL}	Low-level input voltage			0.8	V
I_{OH}	High-level output current			-15	mA
I_{OL}	Low-level output current			12	mA
T_A	Operating free-air temperature	-40		85	°C

NOTE 2: All unused inputs of the device must be held at V_{CC} or GND to ensure proper device operation.

CY74FCT2541T

8-BIT BUFFER/LINE DRIVER

WITH 3-STATE OUTPUTS

SCCS041B – SEPTEMBER 1994 – REVISED SEPTEMBER 2001

electrical characteristics over recommended operating free-air temperature range (unless otherwise noted)

PARAMETER	TEST CONDITIONS		MIN	TYP†	MAX	UNIT
V _{IK}	V _{CC} = 4.75 V,	I _{IN} = -18 mA		-0.7	-1.2	V
V _{OH}	V _{CC} = 4.75 V,	I _{OH} = -15 mA	2.4	3.3		V
V _{OL}	V _{CC} = 4.75 V,	I _{OL} = 12 mA		0.3	0.55	V
R _{out}	V _{CC} = 4.75 V,	I _{OL} = 12 mA	20	25	40	Ω
V _{hys}	All inputs			0.2		V
I _I	V _{CC} = 5.25 V,	V _{IN} = V _{CC}			5	μA
I _{IH}	V _{CC} = 5.25 V,	V _{IN} = 2.7 V			±1	μA
I _{IL}	V _{CC} = 5.25 V,	V _{IN} = 0.5 V			±1	μA
I _{OZH}	V _{CC} = 5.25 V,	V _{OUT} = 2.7 V			15	μA
I _{OZL}	V _{CC} = 5.25 V,	V _{OUT} = 0.5 V			-15	μA
I _{OS} ‡	V _{CC} = 5.25 V,	V _{OUT} = 0 V	-60	-120	-225	mA
I _{off}	V _{CC} = 0 V,	V _{OUT} = 4.5 V			±1	μA
I _{CC}	V _{CC} = 5.25 V,	V _{IN} ≤ 0.2 V, V _{IN} ≥ V _{CC} - 0.2 V		0.1	0.2	mA
ΔI _{CC}	V _{CC} = 5.25 V, V _{IN} = 3.4 V§, f ₁ = 0, Outputs open			0.5	2	mA
I _{CCD} ¶	V _{CC} = 5.25 V at 50% duty cycle, Outputs open, One bit switching, OE _A = OE _B = GND, V _{IN} ≤ 0.2 V or V _{IN} ≥ V _{CC} - 0.2 V			0.06	0.12	mA/MHz
I _C #	V _{CC} = 5.25 V, Outputs open, OE _A = OE _B = GND	One bit switching at f ₁ = 10 MHz, at 50% duty cycle	V _{IN} ≤ 0.2 V or V _{IN} ≥ V _{CC} - 0.2 V	0.7	1.4	mA
			V _{IN} = 3.4 V or GND	1	2.4	
		Eight bits switching at f ₁ = 2.5 MHz, at 50% duty cycle	V _{IN} ≤ 0.2 V or V _{IN} ≥ V _{CC} - 0.2 V	1.3	2.6	
			V _{IN} = 3.4 V or GND	3.3	10.6	
C _i				5	10	pF
C _o				9	12	pF

† Typical values are at V_{CC} = 5 V, T_A = 25°C.

‡ Not more than one output should be shorted at a time. Duration of short should not exceed one second. The use of high-speed test apparatus and/or sample-and-hold techniques are preferable to minimize internal chip heating and more accurately reflect operational values. Otherwise, prolonged shorting of a high output can raise the chip temperature well above normal and cause invalid readings in other parametric tests. In any sequence of parameter tests, I_{OS} tests should be performed last.

§ Per TTL-driven input (V_{IN} = 3.4 V); all other inputs at V_{CC} or GND

¶ This parameter is derived for use in total power-supply calculations.

I_C = I_{CC} + ΔI_{CC} × D_H × N_T + I_{CCD} (f₀/2 + f₁ × N₁)

Where:

I_C = Total supply current

I_{CC} = Power-supply current with CMOS input levels

ΔI_{CC} = Power-supply current for a TTL high input (V_{IN} = 3.4 V)

D_H = Duty cycle for TTL inputs high

N_T = Number of TTL inputs at D_H

I_{CCD} = Dynamic current caused by an input transition pair (HLH or LHL)

f₀ = Clock frequency for registered devices, otherwise zero

f₁ = Input signal frequency

N₁ = Number of inputs changing at f₁

All currents are in milliamperes and all frequencies are in megahertz.

|| Values for these conditions are examples of the I_{CC} formula.



CY74FCT2541T
8-BIT BUFFER/LINE DRIVER
WITH 3-STATE OUTPUTS

SCCS041B – SEPTEMBER 1994 – REVISED SEPTEMBER 2001

switching characteristics over operating free-air temperature range (see Figure 1)

PARAMETER	FROM (INPUT)	TO (OUTPUT)	CY74FCT2541T		CY74FCT2541AT		CY74FCT2541CT		UNIT
			MIN	MAX	MIN	MAX	MIN	MAX	
t _{PLH}	D	O	1.5	8	1.5	4.8	1.5	4.1	ns
t _{PHL}			1.5	8	1.5	4.8	1.5	4.1	
t _{PZH}	\overline{OE}	O	1.5	10	1.5	6.2	1.5	5.8	ns
t _{PZL}			1.5	10	1.5	6.2	1.5	5.8	
t _{PHZ}	\overline{OE}	O	1.5	9.5	1.5	5.6	1.5	5.2	ns
t _{PLZ}			1.5	9.5	1.5	5.6	1.5	5.2	

CY74FCT2541T

8-BIT BUFFER/LINE DRIVER

WITH 3-STATE OUTPUTS

SCCS041B – SEPTEMBER 1994 – REVISED SEPTEMBER 2001

PARAMETER MEASUREMENT INFORMATION

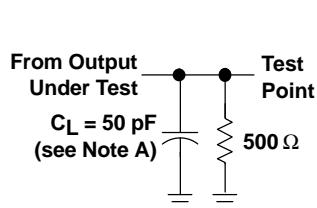

LOAD CIRCUIT FOR TOTEM-POLE OUTPUTS

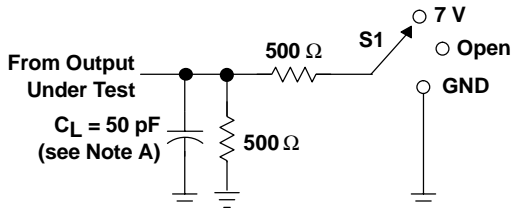

LOAD CIRCUIT FOR 3-STATE OUTPUTS

TEST	S1
t _{PLH} /t _{PHL}	Open
t _{PLZ} /t _{PZL}	7 V
t _{PHZ} /t _{PZH}	Open

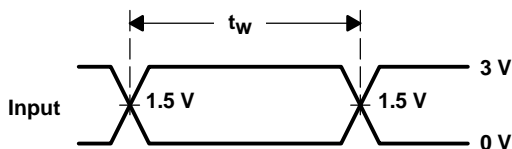

VOLTAGE WAVEFORMS PULSE DURATION

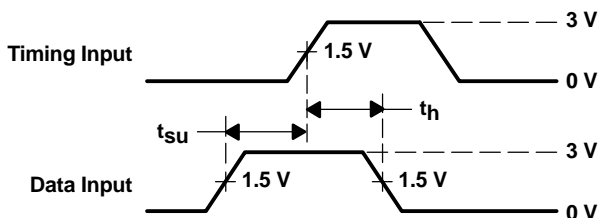

VOLTAGE WAVEFORMS SETUP AND HOLD TIMES

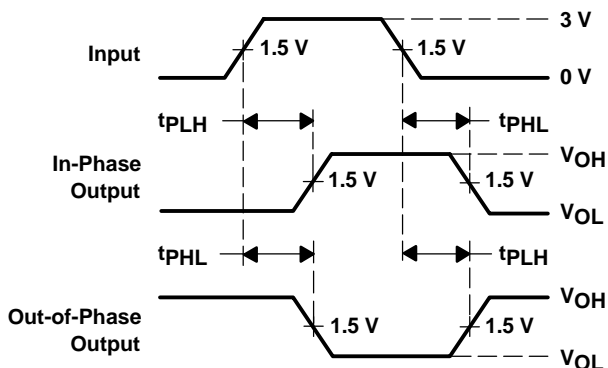

VOLTAGE WAVEFORMS PROPAGATION DELAY TIMES INVERTING AND NONINVERTING OUTPUTS

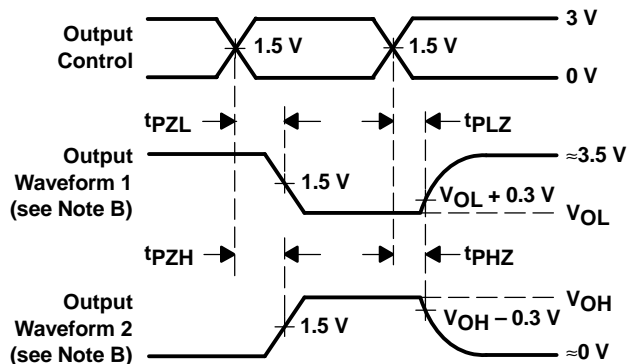

VOLTAGE WAVEFORMS ENABLE AND DISABLE TIMES LOW- AND HIGH-LEVEL ENABLING

- NOTES: A. C_L includes probe and jig capacitance.
 B. Waveform 1 is for an output with internal conditions such that the output is low except when disabled by the output control. Waveform 2 is for an output with internal conditions such that the output is high except when disabled by the output control.
 C. The outputs are measured one at a time with one input transition per measurement.

Figure 1. Load Circuit and Voltage Waveforms

PACKAGING INFORMATION

Orderable Device	Status ⁽¹⁾	Package Type	Package Drawing	Pins	Package Qty	Eco Plan ⁽²⁾	Lead/Ball Finish	MSL Peak Temp ⁽³⁾
CY74FCT2541ATQCT	ACTIVE	SSOP/ QSOP	DBQ	20	2500	Pb-Free (RoHS)	CU NIPDAU	Level-2-260C-1 YEAR/ Level-1-235C-UNLIM
CY74FCT2541ATSOC	ACTIVE	SOIC	DW	20	25	Pb-Free (RoHS)	CU NIPDAU	Level-2-250C-1 YEAR/ Level-1-235C-UNLIM
CY74FCT2541ATSOCT	ACTIVE	SOIC	DW	20	2000	Pb-Free (RoHS)	CU NIPDAU	Level-2-250C-1 YEAR/ Level-1-235C-UNLIM
CY74FCT2541CTQCT	ACTIVE	SSOP/ QSOP	DBQ	20	2500	Pb-Free (RoHS)	CU NIPDAU	Level-2-260C-1 YEAR/ Level-1-235C-UNLIM
CY74FCT2541CTSOC	ACTIVE	SOIC	DW	20	25	Pb-Free (RoHS)	CU NIPDAU	Level-2-250C-1 YEAR/ Level-1-235C-UNLIM
CY74FCT2541CTSOCT	ACTIVE	SOIC	DW	20	2000	Pb-Free (RoHS)	CU NIPDAU	Level-2-250C-1 YEAR/ Level-1-235C-UNLIM
CY74FCT2541TQCT	ACTIVE	SSOP/ QSOP	DBQ	20	2500	Pb-Free (RoHS)	CU NIPDAU	Level-2-260C-1 YEAR/ Level-1-235C-UNLIM
CY74FCT2541TSOC	ACTIVE	SOIC	DW	20	25	Pb-Free (RoHS)	CU NIPDAU	Level-2-250C-1 YEAR/ Level-1-235C-UNLIM
CY74FCT2541TSOCT	ACTIVE	SOIC	DW	20	2000	Pb-Free (RoHS)	CU NIPDAU	Level-2-250C-1 YEAR/ Level-1-235C-UNLIM

⁽¹⁾ The marketing status values are defined as follows:

ACTIVE: Product device recommended for new designs.

LIFEBUY: TI has announced that the device will be discontinued, and a lifetime-buy period is in effect.

NRND: Not recommended for new designs. Device is in production to support existing customers, but TI does not recommend using this part in a new design.

PREVIEW: Device has been announced but is not in production. Samples may or may not be available.

OBSELETE: TI has discontinued the production of the device.

⁽²⁾ Eco Plan - May not be currently available - please check <http://www.ti.com/productcontent> for the latest availability information and additional product content details.

None: Not yet available Lead (Pb-Free).

Pb-Free (RoHS): TI's terms "Lead-Free" or "Pb-Free" mean semiconductor products that are compatible with the current RoHS requirements for all 6 substances, including the requirement that lead not exceed 0.1% by weight in homogeneous materials. Where designed to be soldered at high temperatures, TI Pb-Free products are suitable for use in specified lead-free processes.

Green (RoHS & no Sb/Br): TI defines "Green" to mean "Pb-Free" and in addition, uses package materials that do not contain halogens, including bromine (Br) or antimony (Sb) above 0.1% of total product weight.

⁽³⁾ MSL, Peak Temp. -- The Moisture Sensitivity Level rating according to the JEDEC industry standard classifications, and peak solder temperature.

Important Information and Disclaimer:The information provided on this page represents TI's knowledge and belief as of the date that it is provided. TI bases its knowledge and belief on information provided by third parties, and makes no representation or warranty as to the accuracy of such information. Efforts are underway to better integrate information from third parties. TI has taken and continues to take reasonable steps to provide representative and accurate information but may not have conducted destructive testing or chemical analysis on incoming materials and chemicals. TI and TI suppliers consider certain information to be proprietary, and thus CAS numbers and other limited information may not be available for release.

In no event shall TI's liability arising out of such information exceed the total purchase price of the TI part(s) at issue in this document sold by TI to Customer on an annual basis.

DW (R-PDSO-G20)

PLASTIC SMALL-OUTLINE PACKAGE

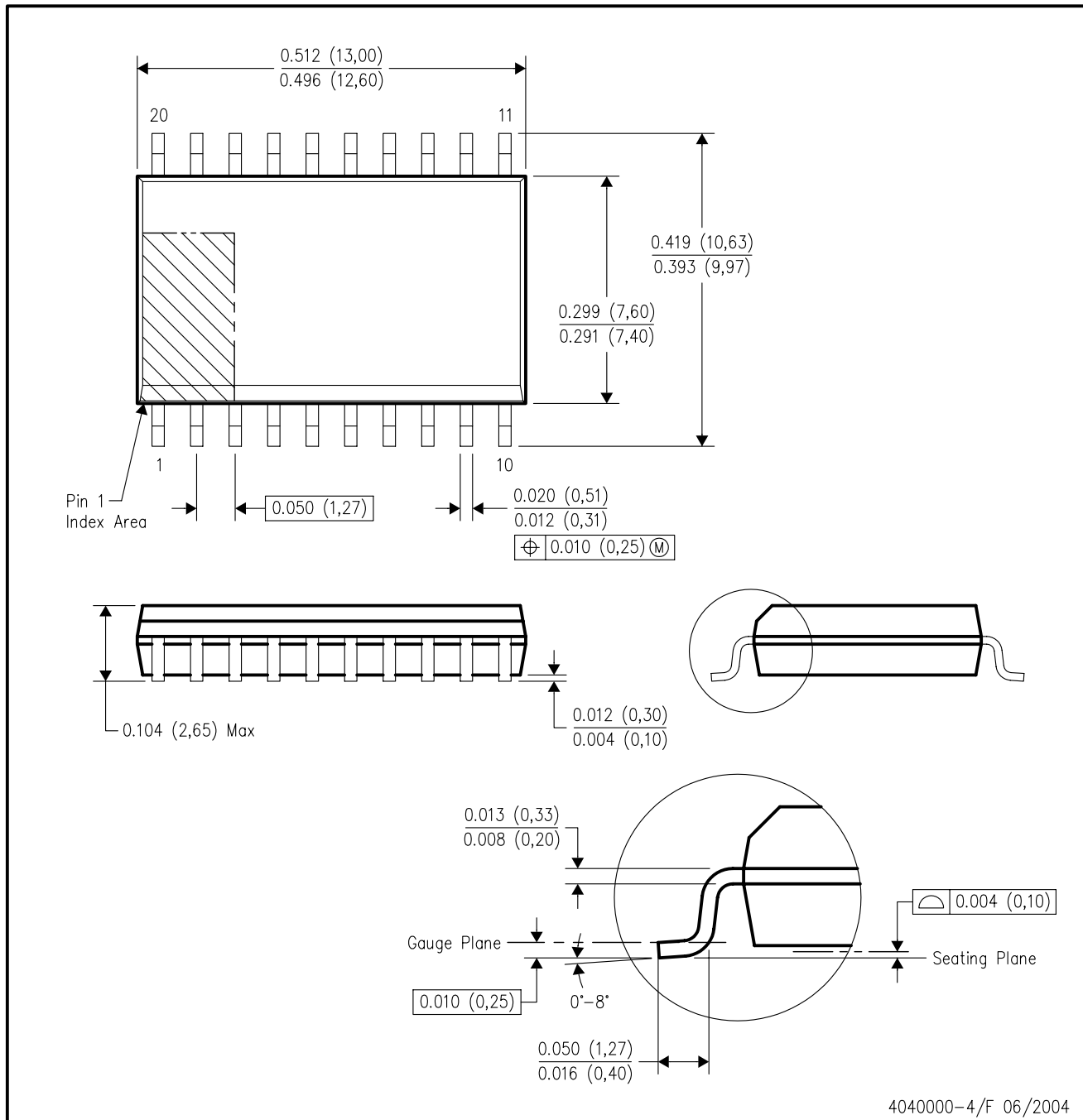

- NOTES:
- A. All linear dimensions are in inches (millimeters).
 - B. This drawing is subject to change without notice.
 - C. Body dimensions do not include mold flash or protrusion not to exceed 0.006 (0,15).
 - D. Falls within JEDEC MS-013 variation AC.

DBQ (R-PDSO-G20)

PLASTIC SMALL-OUTLINE PACKAGE

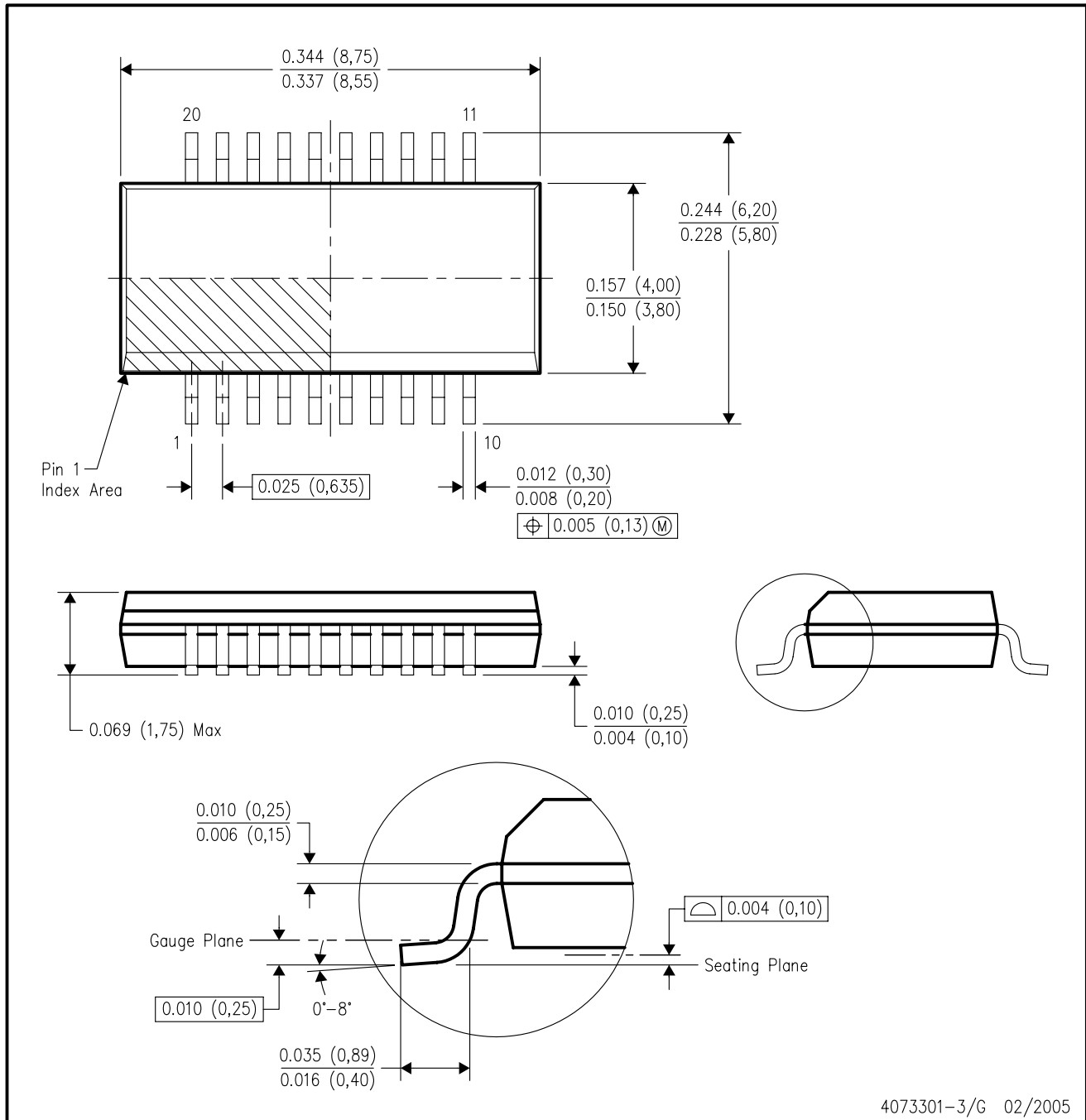

- NOTES:
- A. All linear dimensions are in inches (millimeters).
 - B. This drawing is subject to change without notice.
 - C. Body dimensions do not include mold flash or protrusion not to exceed 0.006 (0,15) per side.
 - D. Falls within JEDEC MO-137 variation AD.

IMPORTANT NOTICE

Texas Instruments Incorporated and its subsidiaries (TI) reserve the right to make corrections, modifications, enhancements, improvements, and other changes to its products and services at any time and to discontinue any product or service without notice. Customers should obtain the latest relevant information before placing orders and should verify that such information is current and complete. All products are sold subject to TI's terms and conditions of sale supplied at the time of order acknowledgment.

TI warrants performance of its hardware products to the specifications applicable at the time of sale in accordance with TI's standard warranty. Testing and other quality control techniques are used to the extent TI deems necessary to support this warranty. Except where mandated by government requirements, testing of all parameters of each product is not necessarily performed.

TI assumes no liability for applications assistance or customer product design. Customers are responsible for their products and applications using TI components. To minimize the risks associated with customer products and applications, customers should provide adequate design and operating safeguards.

TI does not warrant or represent that any license, either express or implied, is granted under any TI patent right, copyright, mask work right, or other TI intellectual property right relating to any combination, machine, or process in which TI products or services are used. Information published by TI regarding third-party products or services does not constitute a license from TI to use such products or services or a warranty or endorsement thereof. Use of such information may require a license from a third party under the patents or other intellectual property of the third party, or a license from TI under the patents or other intellectual property of TI.

Reproduction of information in TI data books or data sheets is permissible only if reproduction is without alteration and is accompanied by all associated warranties, conditions, limitations, and notices. Reproduction of this information with alteration is an unfair and deceptive business practice. TI is not responsible or liable for such altered documentation.

Resale of TI products or services with statements different from or beyond the parameters stated by TI for that product or service voids all express and any implied warranties for the associated TI product or service and is an unfair and deceptive business practice. TI is not responsible or liable for any such statements.

Following are URLs where you can obtain information on other Texas Instruments products and application solutions:

Products		Applications	
Amplifiers	amplifier.ti.com	Audio	www.ti.com/audio
Data Converters	dataconverter.ti.com	Automotive	www.ti.com/automotive
DSP	dsp.ti.com	Broadband	www.ti.com/broadband
Interface	interface.ti.com	Digital Control	www.ti.com/digitalcontrol
Logic	logic.ti.com	Military	www.ti.com/military
Power Mgmt	power.ti.com	Optical Networking	www.ti.com/opticalnetwork
Microcontrollers	microcontroller.ti.com	Security	www.ti.com/security
		Telephony	www.ti.com/telephony
		Video & Imaging	www.ti.com/video
		Wireless	www.ti.com/wireless

Mailing Address: Texas Instruments
Post Office Box 655303 Dallas, Texas 75265