

Precision, Low Power INSTRUMENTATION AMPLIFIERS

FEATURES

- **LOW OFFSET VOLTAGE:** 50µV max
- **LOW DRIFT:** 0.5µV/°C max
- **LOW INPUT BIAS CURRENT:** 5nA max
- **HIGH CMR:** 120dB min
- **INPUTS PROTECTED TO ±40V**
- **WIDE SUPPLY RANGE:** ±2.25V to ±18V
- **LOW QUIESCENT CURRENT:** 700µA
- **8-PIN PLASTIC DIP, SO-8**

APPLICATIONS

- **BRIDGE AMPLIFIER**
- **THERMOCOUPLE AMPLIFIER**
- **RTD SENSOR AMPLIFIER**
- **MEDICAL INSTRUMENTATION**
- **DATA ACQUISITION**

DESCRIPTION

The INA128 and INA129 are low power, general purpose instrumentation amplifiers offering excellent accuracy. The versatile 3-op amp design and small size make them ideal for a wide range of applications. Current-feedback input circuitry provides wide bandwidth even at high gain (200kHz at G = 100).

A single external resistor sets any gain from 1 to 10,000. The INA128 provides an industry-standard gain equation; the INA129 gain equation is compatible with the AD620.

The INA128/INA129 is laser trimmed for very low offset voltage (50µV), drift (0.5µV/°C) and high common-mode rejection (120dB at G ≥ 100). It operates with power supplies as low as ±2.25V, and quiescent current is only 700µA—ideal for battery-operated systems. Internal input protection can withstand up to ±40V without damage.

The INA128/INA129 is available in 8-pin plastic DIP and SO-8 surface-mount packages, specified for the –40°C to +85°C temperature range. The INA128 is also available in a dual configuration, the INA218.

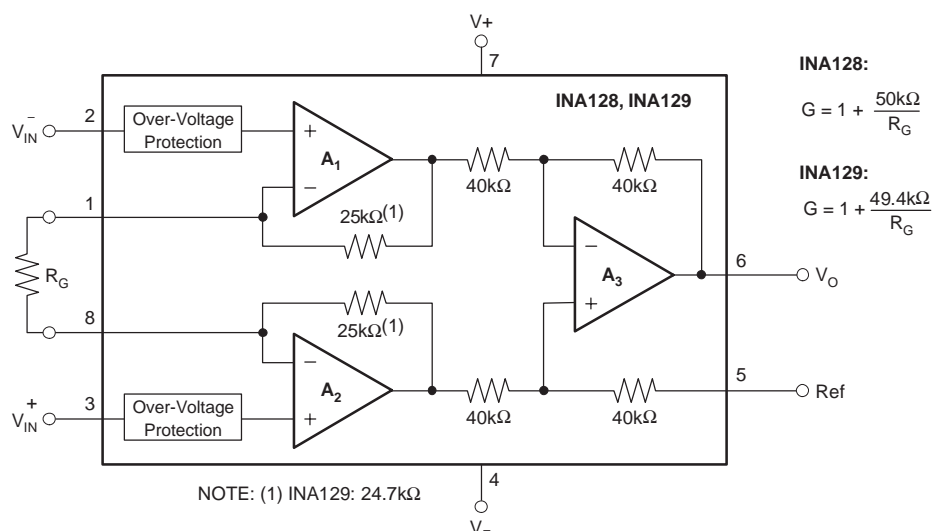

Please be aware that an important notice concerning availability, standard warranty, and use in critical applications of Texas Instruments semiconductor products and disclaimers thereto appears at the end of this data sheet.

All trademarks are the property of their respective owners.

ABSOLUTE MAXIMUM RATINGS(1)

Supply Voltage	±18V
Analog Input Voltage Range	±40V
Output Short-Circuit (to ground)	Continuous
Operating Temperature	-40°C to +125°C
Storage Temperature Range	-55°C to +125°C
Junction Temperature	+150°C
Lead Temperature (soldering, 10s)	+300°C

(1) Stresses above these ratings may cause permanent damage. Exposure to absolute maximum conditions for extended periods may degrade device reliability. These are stress ratings only, and functional operation of the device at these or any other conditions beyond those specified is not implied.

ELECTROSTATIC DISCHARGE SENSITIVITY



This integrated circuit can be damaged by ESD. Texas Instruments recommends that all integrated circuits be handled with appropriate precautions. Failure to observe proper handling and installation procedures can cause damage.

ESD damage can range from subtle performance degradation to complete device failure. Precision integrated circuits may be more susceptible to damage because very small parametric changes could cause the device not to meet its published specifications.

ORDERING INFORMATION

For the most current package and ordering information, see the Package Option Addendum located at the end of this data sheet.

PIN CONFIGURATION

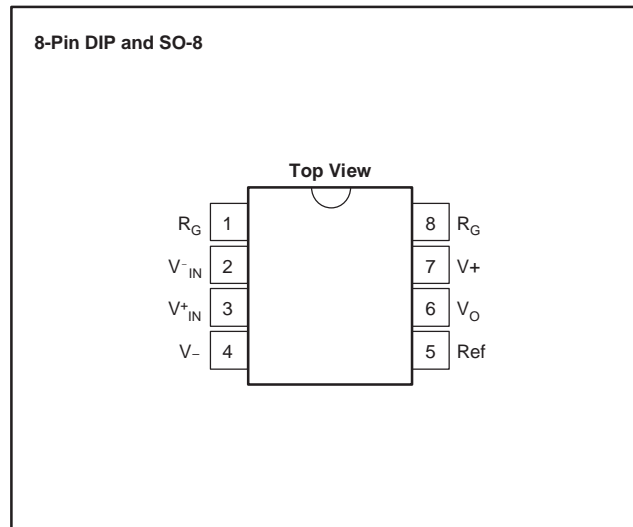

ELECTRICAL CHARACTERISTICS

At $T_A = +25^\circ\text{C}$, $V_S = \pm 15\text{V}$, $R_L = 10\text{k}\Omega$, unless otherwise noted.

PARAMETER	CONDITIONS	INA128P, U INA129P, U			INA128PA, UA INA129PA, UA			UNIT
		MIN	TYP	MAX	MIN	TYP	MAX	
INPUT								
Offset Voltage, RTI								
Initial	$T_A = +25^\circ\text{C}$		$\pm 10 \pm 100/\text{G}$	$\pm 50 \pm 500/\text{G}$		$\pm 25 \pm 100/\text{G}$	$\pm 125 \pm 1000/\text{G}$	μV
vs Temperature	$T_A = T_{\text{MIN}}$ to T_{MAX}		$\pm 0.2 \pm 2/\text{G}$	$\pm 0.5 \pm 20/\text{G}$		$\pm 0.2 \pm 5/\text{G}$	$\pm 1 \pm 20/\text{G}$	$\mu\text{V}/^\circ\text{C}$
vs Power Supply	$V_S = \pm 2.25\text{V}$ to $\pm 18\text{V}$		$\pm 0.2 \pm 20/\text{G}$	$\pm 1 \pm 100/\text{G}$		*	$\pm 2 \pm 200/\text{G}$	$\mu\text{V}/\text{V}$
Long-Term Stability			$\pm 0.1 \pm 3/\text{G}$			*		$\mu\text{V}/\text{mo}$
Impedance, Differential			$10^{10} \parallel 2$			*		$\Omega \parallel \text{pF}$
Common-Mode			$10^{11} \parallel 9$			*		$\Omega \parallel \text{pF}$
Common-Mode Voltage Range ⁽¹⁾	$V_O = 0\text{V}$	$(V+) - 2$ $(V-) + 2$	$(V+) - 1.4$ $(V-) + 1.7$		*	*		V
Safe Input Voltage				± 40		*	*	V
Common-Mode Rejection	$V_{\text{CM}} = \pm 13\text{V}$, $\Delta R_S = 1\text{k}\Omega$						*	
	$G = 1$	80	86		73	*		dB
	$G = 10$	100	106		93	*		dB
	$G = 100$	120	125		110	*		dB
	$G = 1000$	120	130		110	*		dB
BIAS CURRENT								
vs Temperature			± 2	± 5		*	± 10	nA
Offset Current			± 30			*		$\text{pA}/^\circ\text{C}$
vs Temperature			± 1	± 5		*	± 10	nA
			± 30			*		$\text{pA}/^\circ\text{C}$
NOISE VOLTAGE, RTI								
	$G = 1000$, $R_S = 0\Omega$							
$f = 10\text{Hz}$			10			*		$\text{nV}/\sqrt{\text{Hz}}$
$f = 100\text{Hz}$			8			*		$\text{nV}/\sqrt{\text{Hz}}$
$f = 1\text{kHz}$			8			*		$\text{nV}/\sqrt{\text{Hz}}$
$f_B = 0.1\text{Hz}$ to 10Hz			0.2			*		μV_{pp}
Noise Current								
$f = 10\text{Hz}$			0.9			*		$\text{pA}/\sqrt{\text{Hz}}$
$f = 1\text{kHz}$			0.3			*		$\text{pA}/\sqrt{\text{Hz}}$
$f_B = 0.1\text{Hz}$ to 10Hz			30			*		pA_{pp}
GAIN								
Gain Equation, INA128			$1 + (50\text{k}\Omega/R_G)$			*		V/V
INA129			$1 + (49.4\text{k}\Omega/R_G)$			*		V/V
Range of Gain		1		10000	*		*	V/V
Gain Error	$G = 1$		± 0.01	± 0.024		*	± 0.1	%
	$G = 10$		± 0.02	± 0.4		*	± 0.5	%
	$G = 100$		± 0.05	± 0.5		*	± 0.7	%
	$G = 1000$		± 0.5	± 1		*	± 2	%
Gain vs Temperature ⁽²⁾	$G = 1$		± 1	± 10		*	*	$\text{ppm}/^\circ\text{C}$
$50\text{k}\Omega$ (or $49.4\text{k}\Omega$) Resistance ⁽²⁾⁽³⁾			± 25	± 100		*	*	$\text{ppm}/^\circ\text{C}$
Nonlinearity	$V_O = \pm 13.6\text{V}$, $G = 1$		± 0.0001	± 0.001		*	± 0.002	% of FSR
	$G = 10$		± 0.0003	± 0.002		*	± 0.004	% of FSR
	$G = 100$		± 0.0005	± 0.002		*	± 0.004	% of FSR
	$G = 1000$		± 0.001	(4)		*	*	% of FSR

NOTE: * Specification is same as INA128P, U or INA129P, U.

(1) Input common-mode range varies with output voltage — see typical curves.

(2) Specified by wafer test.

(3) Temperature coefficient of the $50\text{k}\Omega$ (or $49.4\text{k}\Omega$) term in the gain equation.

(4) Nonlinearity measurements in $G = 1000$ are dominated by noise. Typical nonlinearity is $\pm 0.001\%$.

ELECTRICAL CHARACTERISTICS (continued)

At $T_A = +25^\circ\text{C}$, $V_S = \pm 15\text{V}$, $R_L = 10\text{k}\Omega$, unless otherwise noted.

PARAMETER	CONDITIONS	INA128P, U INA129P, U			INA128PA, UA INA129PA, UA			UNIT
		MIN	TYP	MAX	MIN	TYP	MAX	
OUTPUT								
Voltage: Positive	$R_L = 10\text{k}\Omega$	$(V+) - 1.4$	$(V+) - 0.9$		*	*		V
Negative	$R_L = 10\text{k}\Omega$	$(V-) + 1.4$	$(V-) + 0.8$		*	*		V
Load Capacitance Stability			1000			*		pF
Short-Circuit Current			+6/-15			*		mA
FREQUENCY RESPONSE								
Bandwidth, -3dB	G = 1		1.3			*		MHz
	G = 10		700			*		kHz
	G = 100		200			*		kHz
	G = 1000		20			*		kHz
Slew Rate	$V_O = \pm 10\text{V}$, G = 10		4			*		V/ μs
Settling Time, 0.01%	G = 1		7			*		μs
	G = 10		7			*		μs
	G = 100		9			*		μs
	G = 1000		80			*		μs
Overload Recovery	50% Overdrive		4			*		μs
POWER SUPPLY								
Voltage Range		± 2.25	± 15	± 18	*	*	*	V
Current, Total	$V_{IN} = 0\text{V}$		± 700	± 750		*	*	μA
TEMPERATURE RANGE								
Specification		-40		+85	*		*	$^\circ\text{C}$
Operating		-40		+125	*		*	$^\circ\text{C}$
θ_{JA}	8-Pin DIP		80			*		$^\circ\text{C/W}$
	SO-8 SOIC		150			*		$^\circ\text{C/W}$

NOTE: * Specification is same as INA128P, U or INA129P, U.

(1) Input common-mode range varies with output voltage — see typical curves.

(2) Specified by wafer test.

(3) Temperature coefficient of the $50\text{k}\Omega$ (or $49.4\text{k}\Omega$) term in the gain equation.

(4) Nonlinearity measurements in G = 1000 are dominated by noise. Typical nonlinearity is $\pm 0.001\%$.

TYPICAL CHARACTERISTICS

At $T_A = +25^\circ\text{C}$, $V_S = \pm 15\text{V}$, unless otherwise noted.

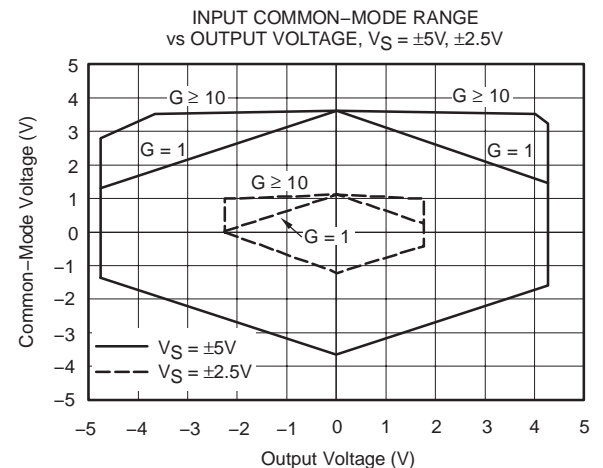
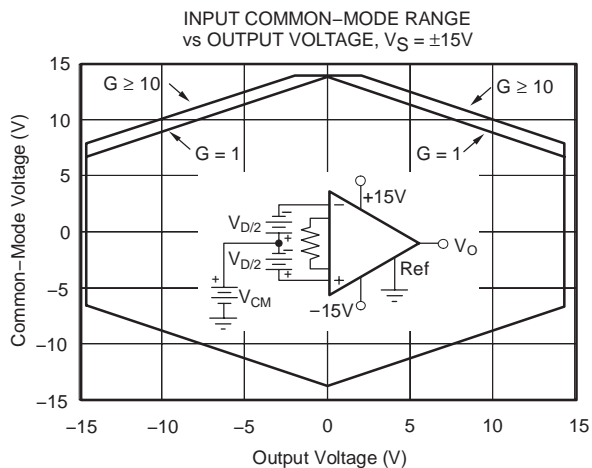
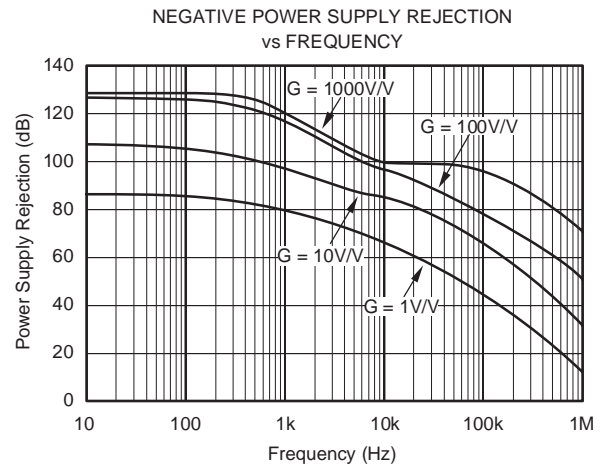
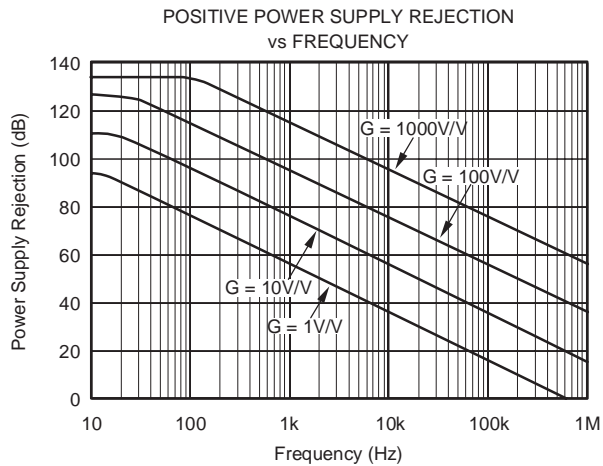
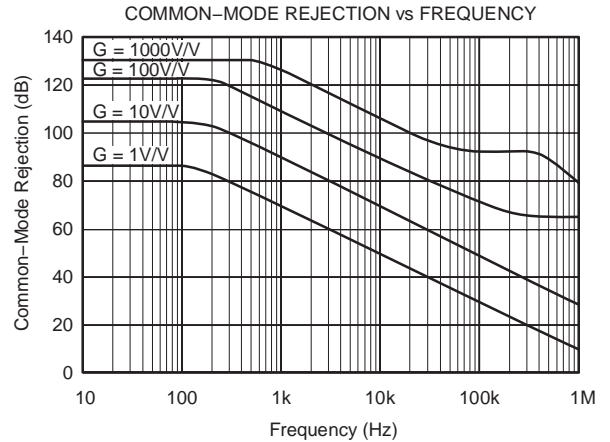
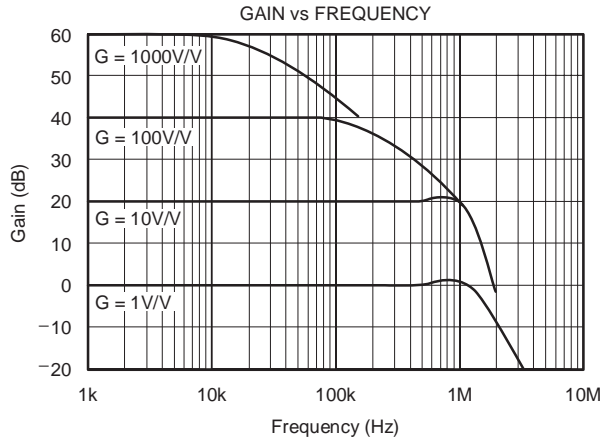

TYPICAL CHARACTERISTICS (continued)

At $T_A = +25^\circ\text{C}$, $V_S = \pm 15\text{V}$, unless otherwise noted.

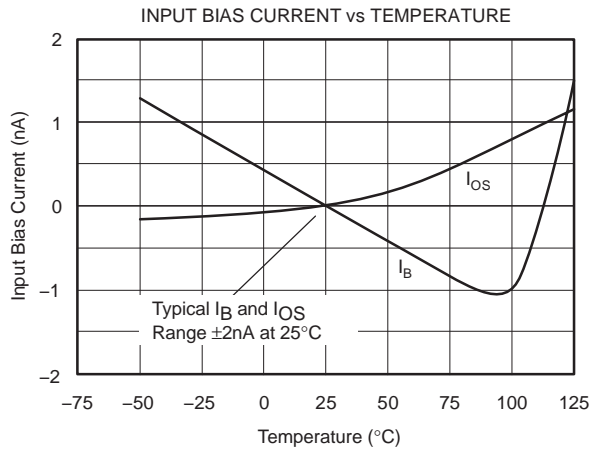
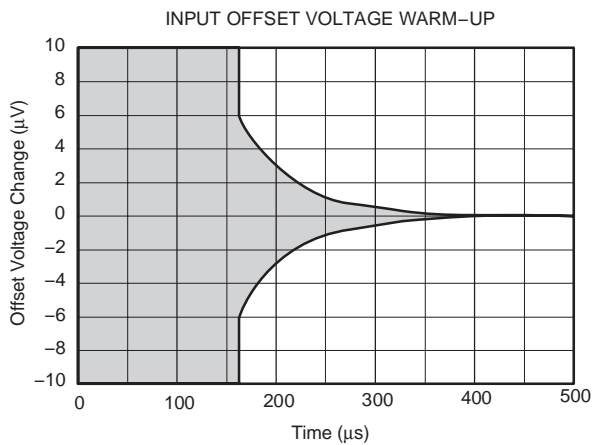
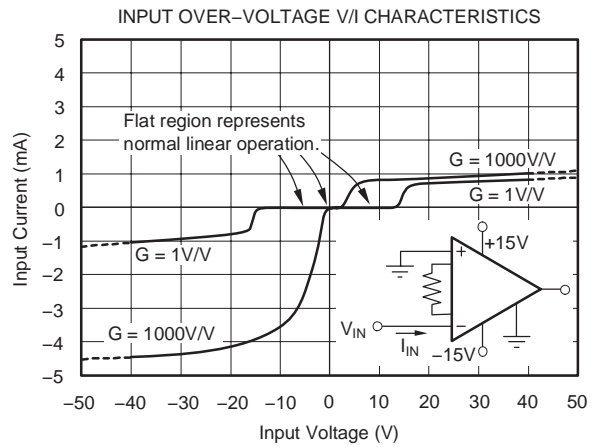
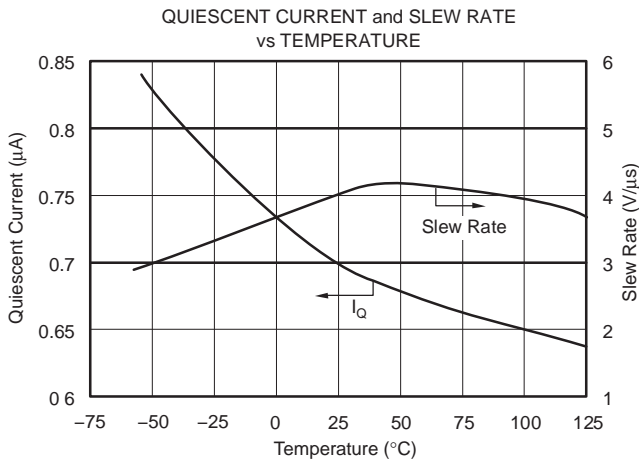
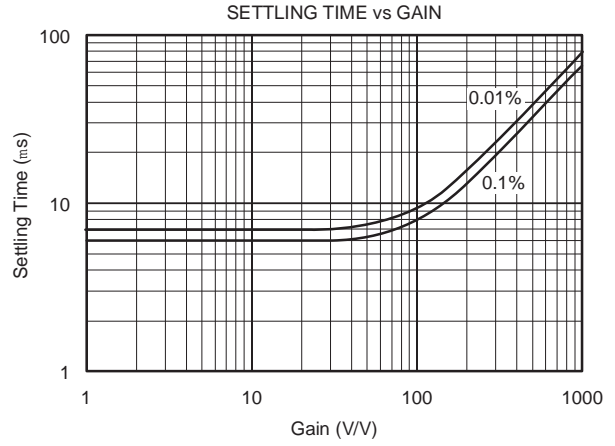
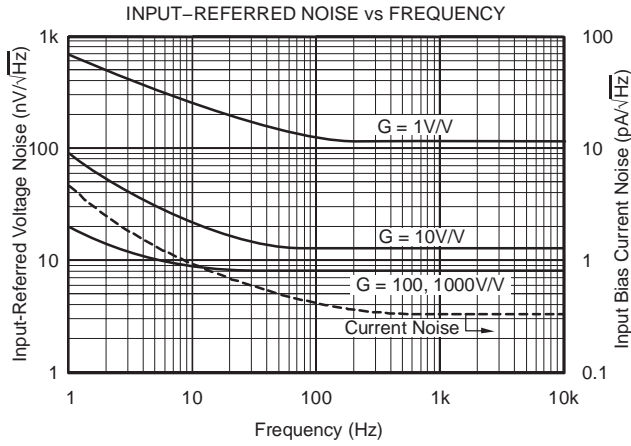

TYPICAL CHARACTERISTICS (continued)

At $T_A = +25^\circ\text{C}$, $V_S = \pm 15\text{V}$, unless otherwise noted.

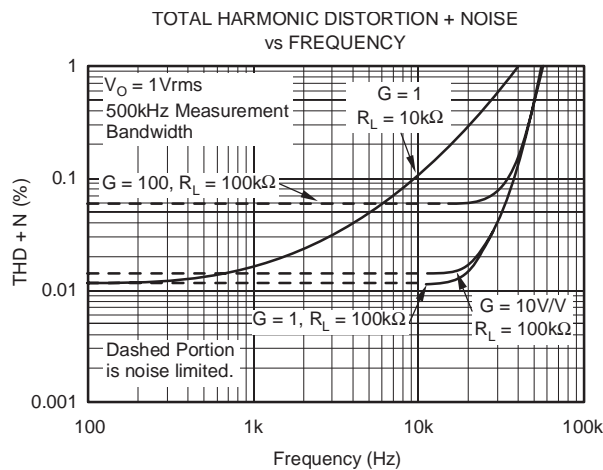
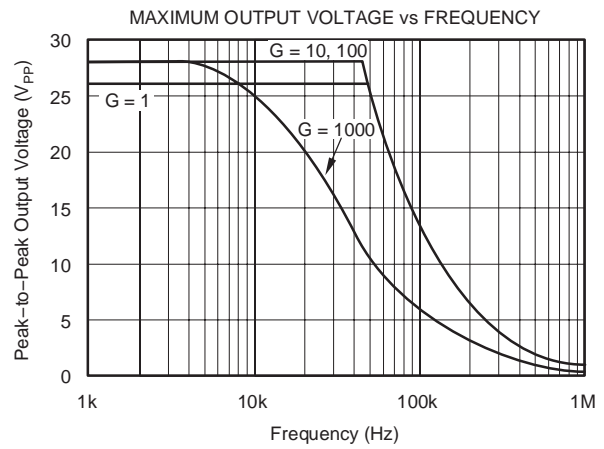
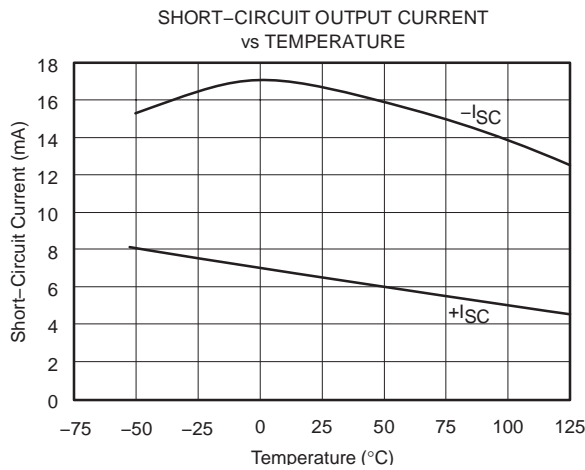
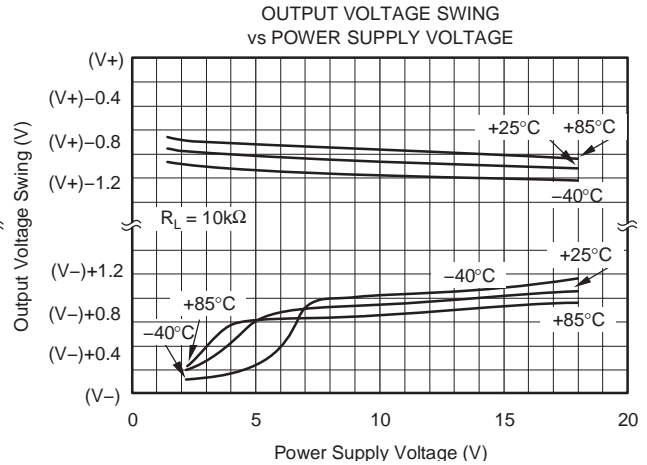
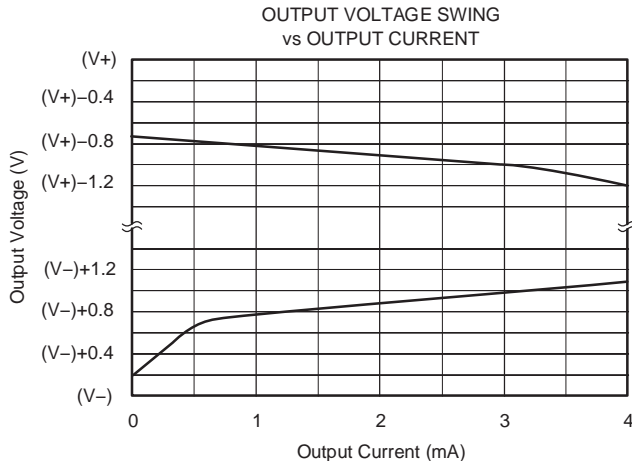

TYPICAL CHARACTERISTICS (continued)

At $T_A = +25^\circ\text{C}$, $V_S = \pm 15\text{V}$, unless otherwise noted.

SMALL SIGNAL
(G = 1, 10)

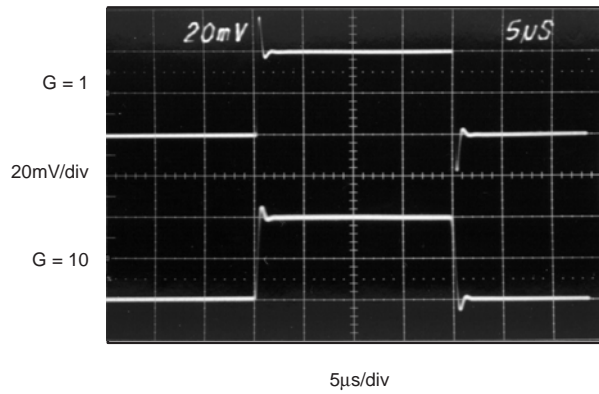

SMALL SIGNAL
(G = 100, 1000)

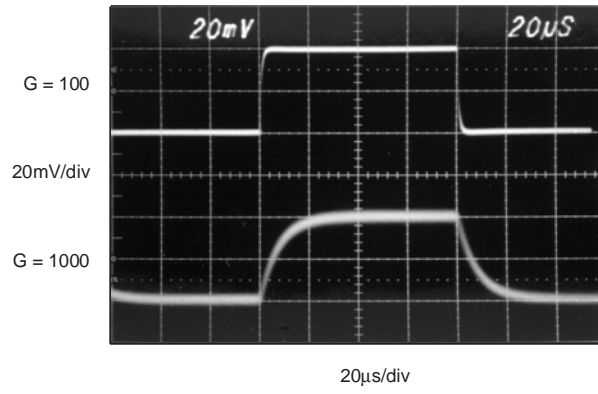

LARGE SIGNAL
(G = 1, 10)

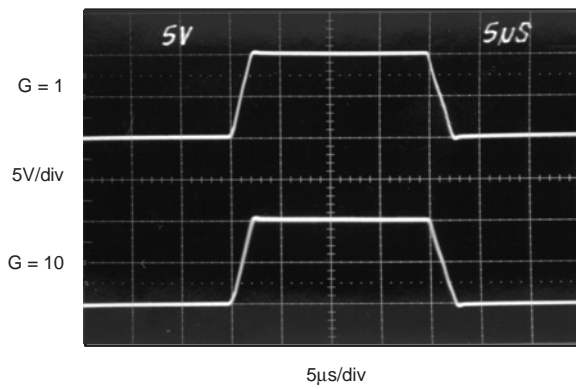

LARGE SIGNAL
(G = 100, 1000)

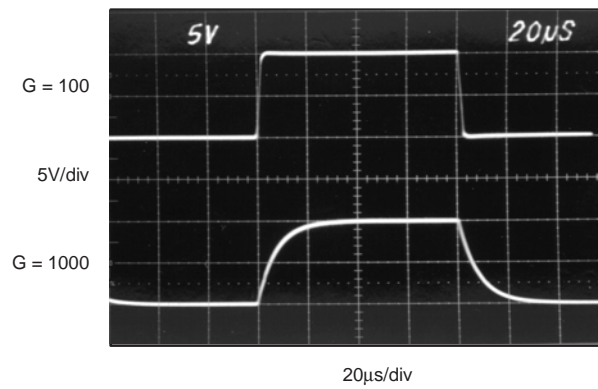

VOLTAGE NOISE 0.1 to 10Hz
INPUT-REFERRED, G ≥ 100

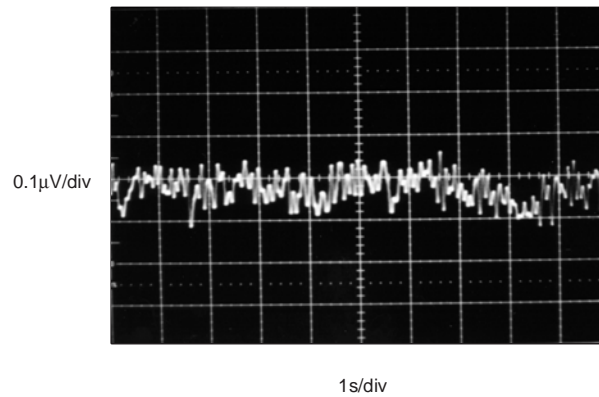

APPLICATIONS INFORMATION

Figure 1 shows the basic connections required for operation of the INA128/INA129. Applications with noisy or high impedance power supplies may require decoupling capacitors close to the device pins as shown.

The output is referred to the output reference (Ref) terminal which is normally grounded. This must be a low-impedance connection to assure good common-mode rejection. A resistance of 8Ω in series with the Ref pin will cause a typical device to degrade to approximately 80dB CMR ($G = 1$).

SETTING THE GAIN

Gain is set by connecting a single external resistor, R_G , connected between pins 1 and 8:

INA128:

$$G = 1 + \frac{50k\Omega}{R_G} \quad (1)$$

INA129:

$$G = 1 + \frac{49.4k\Omega}{R_G} \quad (2)$$

Commonly used gains and resistor values are shown in Figure 1.

The 50kΩ term in Equation 1 (49.4kΩ in Equation 2) comes from the sum of the two internal feedback resistors of A_1 and A_2 . These on-chip metal film

resistors are laser trimmed to accurate absolute values. The accuracy and temperature coefficient of these internal resistors are included in the gain accuracy and drift specifications of the INA128/INA129.

The stability and temperature drift of the external gain setting resistor, R_G , also affects gain. R_G 's contribution to gain accuracy and drift can be directly inferred from the gain equation (1). Low resistor values required for high gain can make wiring resistance important. Sockets add to the wiring resistance which will contribute additional gain error (possibly an unstable gain error) in gains of approximately 100 or greater.

DYNAMIC PERFORMANCE

The typical performance curve *Gain vs Frequency* shows that, despite its low quiescent current, the INA128/INA129 achieves wide bandwidth, even at high gain. This is due to the current-feedback topology of the input stage circuitry. Settling time also remains excellent at high gain.

NOISE PERFORMANCE

The INA128/INA129 provides very low noise in most applications. Low frequency noise is approximately $0.2\mu V_{PP}$ measured from 0.1 to 10Hz ($G \geq 100$). This provides dramatically improved noise when compared to state-of-the-art chopper-stabilized amplifiers.

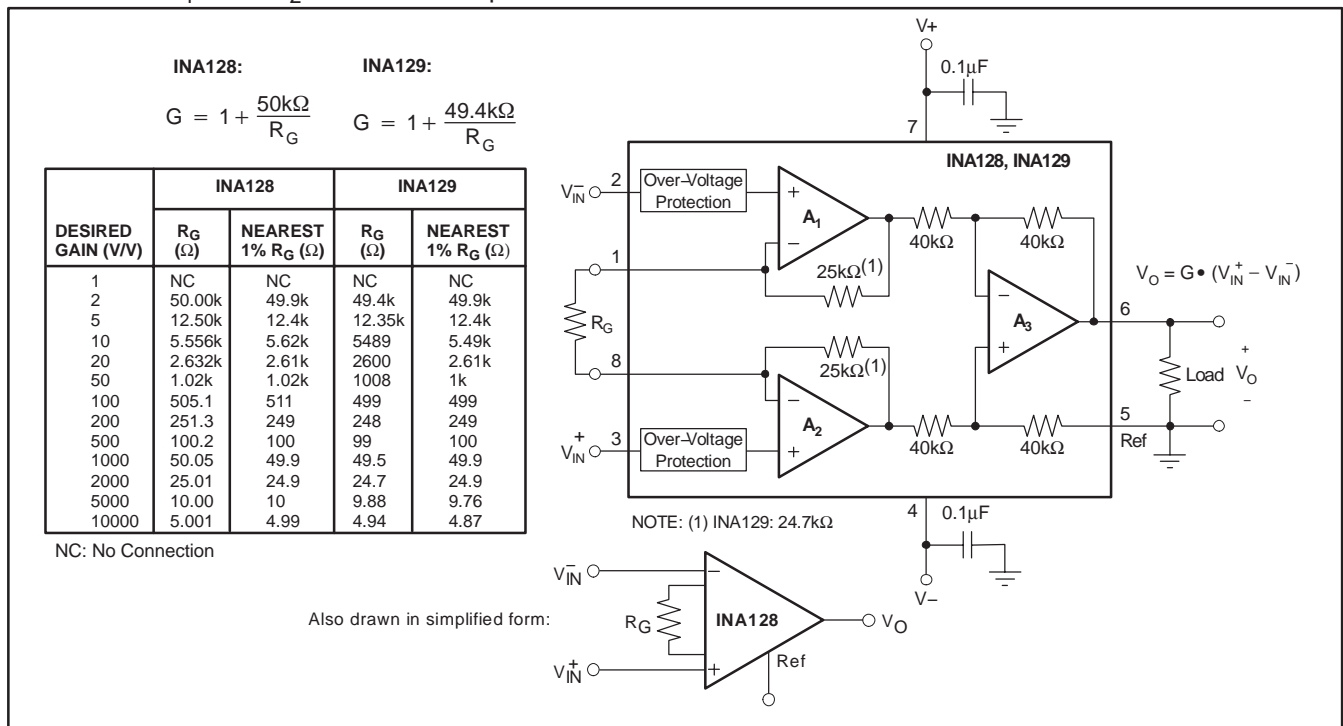

Figure 1. Basic Connections

OFFSET TRIMMING

The INA128/INA129 is laser trimmed for low offset voltage and offset voltage drift. Most applications require no external offset adjustment. Figure 2 shows an optional circuit for trimming the output offset voltage. The voltage applied to Ref terminal is summed with the output. The op amp buffer provides low impedance at the Ref terminal to preserve good common-mode rejection.

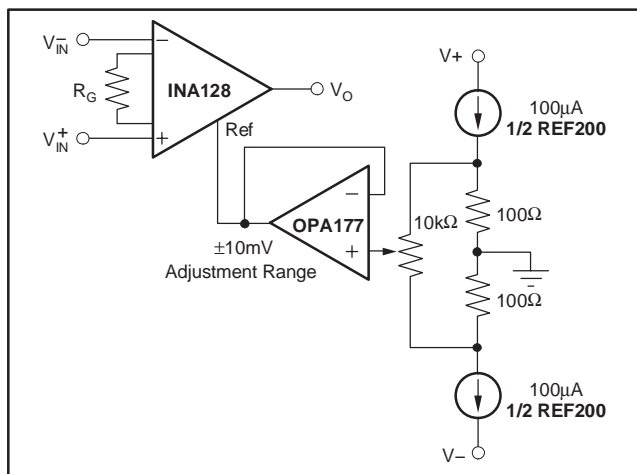

Figure 2. Optional Trimming of Output Offset Voltage

INPUT BIAS CURRENT RETURN PATH

The input impedance of the INA128/INA129 is extremely high—approximately $10^{10}\Omega$. However, a path must be provided for the input bias current of both inputs. This input bias current is approximately $\pm 2\text{nA}$. High input impedance means that this input bias current changes very little with varying input voltage.

Input circuitry must provide a path for this input bias current for proper operation. Figure 3 shows various provisions for an input bias current path. Without a bias current path, the inputs will float to a potential which exceeds the common-mode range, and the input amplifiers will saturate.

If the differential source resistance is low, the bias current return path can be connected to one input (see the thermocouple example in Figure 3). With higher source impedance, using two equal resistors provides a balanced input with possible advantages of lower input offset voltage due to bias current and better high-frequency common-mode rejection.

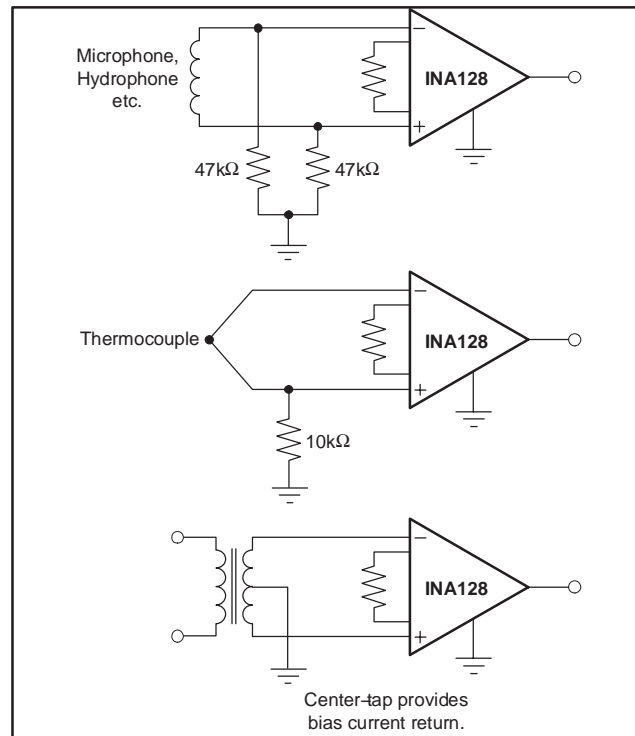

Figure 3. Providing an Input Common-Mode Current Path

INPUT COMMON-MODE RANGE

The linear input voltage range of the input circuitry of the INA128/INA129 is from approximately 1.4V below the positive supply voltage to 1.7V above the negative supply. As a differential input voltage causes the output voltage increase, however, the linear input range will be limited by the output voltage swing of amplifiers A_1 and A_2 . So the linear common-mode input range is related to the output voltage of the complete amplifier. This behavior also depends on supply voltage—see performance curves, *Input Common-Mode Range vs Output Voltage*.

Input-overload can produce an output voltage that appears normal. For example, if an input overload condition drives both input amplifiers to their positive output swing limit, the difference voltage measured by the output amplifier will be near zero. The output of A_3 will be near 0V even though both inputs are overloaded.

LOW VOLTAGE OPERATION

The INA128/INA129 can be operated on power supplies as low as $\pm 2.25\text{V}$. Performance remains excellent with power supplies ranging from $\pm 2.25\text{V}$ to $\pm 18\text{V}$. Most parameters vary only slightly throughout this supply voltage range—see typical performance curves.

Operation at very low supply voltage requires careful attention to assure that the input voltages remain within their linear range. Voltage swing requirements of internal nodes limit the input common-mode range with low power supply voltage. Typical performance curves, "Input Common-Mode Range vs Output Voltage" show the range of linear operation for $\pm 15V$, $\pm 5V$, and $\pm 2.5V$ supplies.

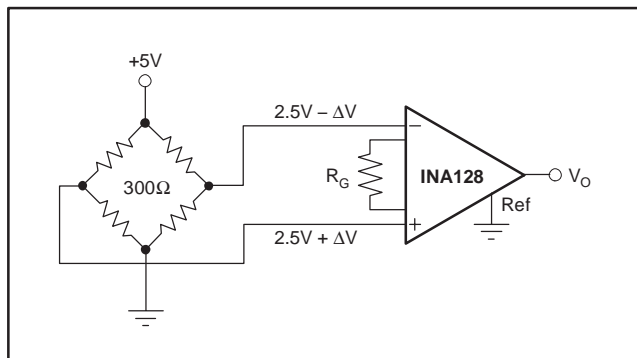

Figure 4. Bridge Amplifier

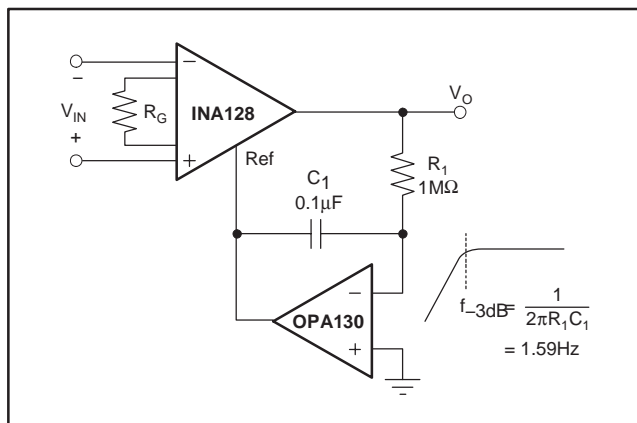

Figure 5. AC-Coupled Instrumentation Amplifier

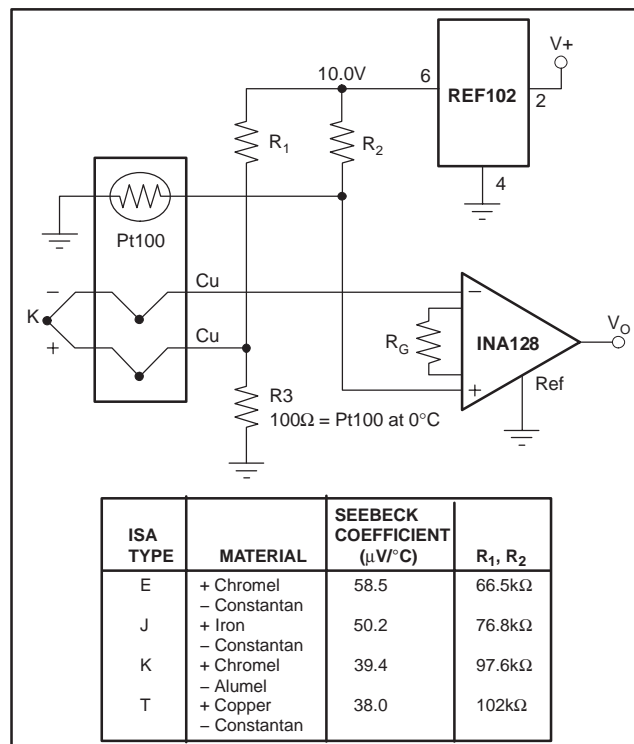

Figure 6. Thermocouple Amplifier with RTD Cold-Junction Compensation

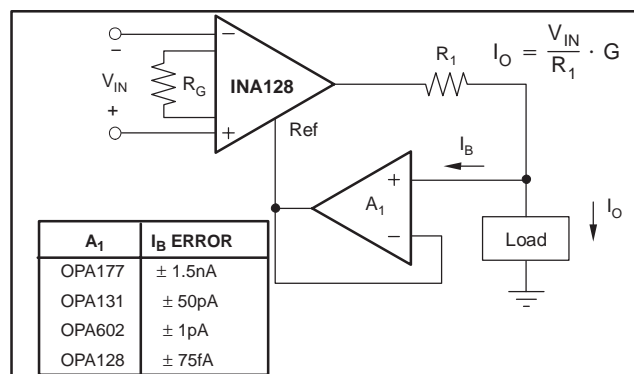

Figure 7. Differential Voltage to Current Converter

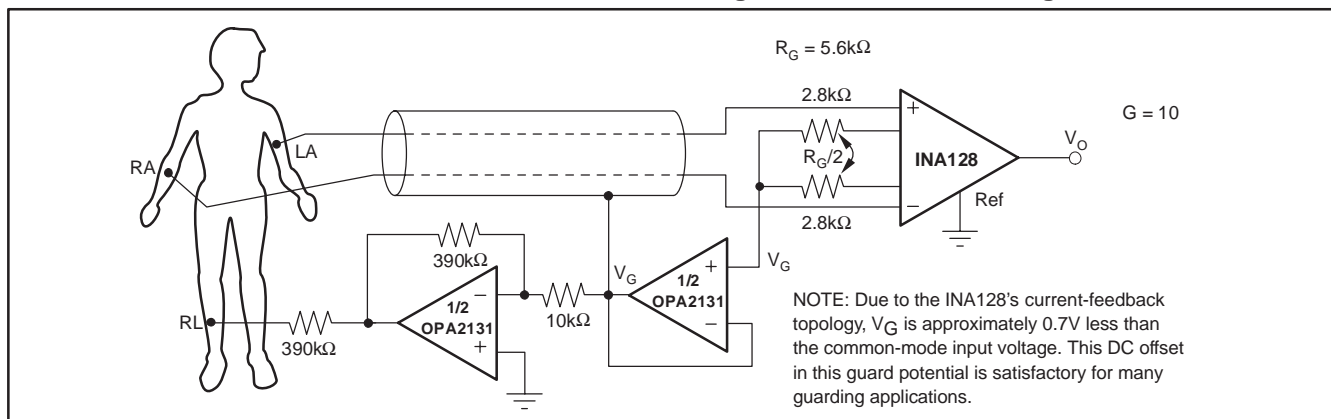

Figure 8. ECG Amplifier with Right-Leg Drive

PACKAGING INFORMATION

Orderable Device	Status ⁽¹⁾	Package Type	Package Drawing	Pins	Package Qty	Eco Plan ⁽²⁾	Lead/Ball Finish	MSL Peak Temp ⁽³⁾
INA128P	ACTIVE	PDIP	P	8	50	None	Call TI	Level-NA-NA-NA
INA128PA	ACTIVE	PDIP	P	8	50	None	Call TI	Level-NA-NA-NA
INA128U	ACTIVE	SOIC	D	8	100	None	Call TI	Call TI
INA128U/2K5	ACTIVE	SOIC	D	8	2500	None	Call TI	Call TI
INA128UA	ACTIVE	SOIC	D	8	100	None	Call TI	Call TI
INA128UA/2K5	ACTIVE	SOIC	D	8	2500	None	CU NIPDAU	Level-2-220C-1 YEAR
INA129P	ACTIVE	PDIP	P	8	50	None	Call TI	Level-NA-NA-NA
INA129PA	ACTIVE	PDIP	P	8	50	None	Call TI	Level-NA-NA-NA
INA129U	ACTIVE	SOIC	D	8	100	None	CU SNPB	Level-3-220C-168 HR
INA129U/2K5	ACTIVE	SOIC	D	8	2500	None	CU SNPB	Level-3-220C-168 HR
INA129UA	ACTIVE	SOIC	D	8	100	None	CU NIPDAU	Level-3-220C-168 HR
INA129UA/2K5	ACTIVE	SOIC	D	8	2500	None	CU NIPDAU	Level-3-220C-168 HR

⁽¹⁾ The marketing status values are defined as follows:

ACTIVE: Product device recommended for new designs.

LIFEBUY: TI has announced that the device will be discontinued, and a lifetime-buy period is in effect.

NRND: Not recommended for new designs. Device is in production to support existing customers, but TI does not recommend using this part in a new design.

PREVIEW: Device has been announced but is not in production. Samples may or may not be available.

OBsolete: TI has discontinued the production of the device.

⁽²⁾ Eco Plan - May not be currently available - please check <http://www.ti.com/productcontent> for the latest availability information and additional product content details.

None: Not yet available Lead (Pb-Free).

Pb-Free (RoHS): TI's terms "Lead-Free" or "Pb-Free" mean semiconductor products that are compatible with the current RoHS requirements for all 6 substances, including the requirement that lead not exceed 0.1% by weight in homogeneous materials. Where designed to be soldered at high temperatures, TI Pb-Free products are suitable for use in specified lead-free processes.

Green (RoHS & no Sb/Br): TI defines "Green" to mean "Pb-Free" and in addition, uses package materials that do not contain halogens, including bromine (Br) or antimony (Sb) above 0.1% of total product weight.

⁽³⁾ MSL, Peak Temp. -- The Moisture Sensitivity Level rating according to the JEDEC industry standard classifications, and peak solder temperature.

Important Information and Disclaimer: The information provided on this page represents TI's knowledge and belief as of the date that it is provided. TI bases its knowledge and belief on information provided by third parties, and makes no representation or warranty as to the accuracy of such information. Efforts are underway to better integrate information from third parties. TI has taken and continues to take reasonable steps to provide representative and accurate information but may not have conducted destructive testing or chemical analysis on incoming materials and chemicals. TI and TI suppliers consider certain information to be proprietary, and thus CAS numbers and other limited information may not be available for release.

In no event shall TI's liability arising out of such information exceed the total purchase price of the TI part(s) at issue in this document sold by TI to Customer on an annual basis.

P (R-PDIP-T8)

PLASTIC DUAL-IN-LINE

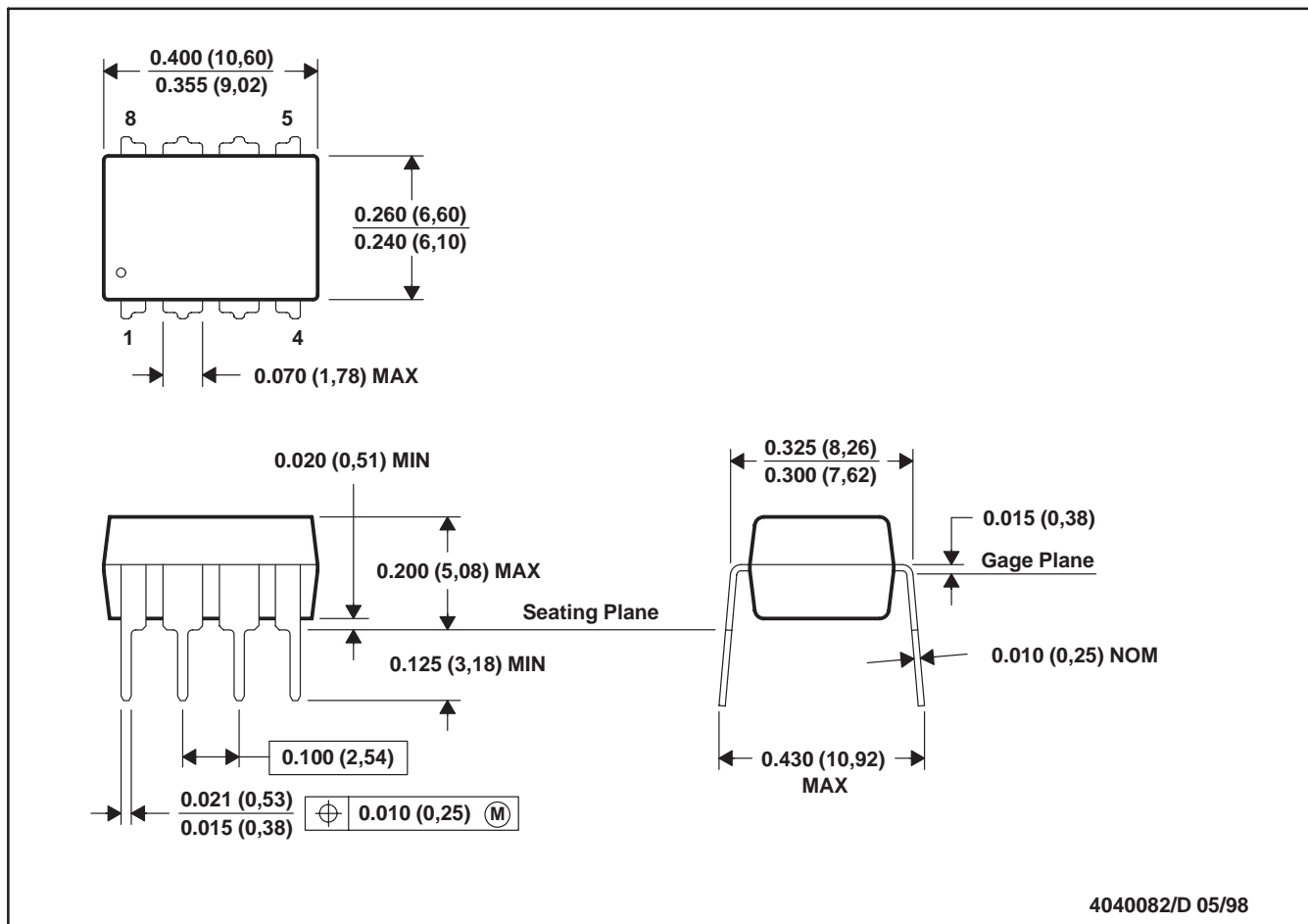

- NOTES: A. All linear dimensions are in inches (millimeters).
 B. This drawing is subject to change without notice.
 C. Falls within JEDEC MS-001

For the latest package information, go to http://www.ti.com/sc/docs/package/pkg_info.htm

IMPORTANT NOTICE

Texas Instruments Incorporated and its subsidiaries (TI) reserve the right to make corrections, modifications, enhancements, improvements, and other changes to its products and services at any time and to discontinue any product or service without notice. Customers should obtain the latest relevant information before placing orders and should verify that such information is current and complete. All products are sold subject to TI's terms and conditions of sale supplied at the time of order acknowledgment.

TI warrants performance of its hardware products to the specifications applicable at the time of sale in accordance with TI's standard warranty. Testing and other quality control techniques are used to the extent TI deems necessary to support this warranty. Except where mandated by government requirements, testing of all parameters of each product is not necessarily performed.

TI assumes no liability for applications assistance or customer product design. Customers are responsible for their products and applications using TI components. To minimize the risks associated with customer products and applications, customers should provide adequate design and operating safeguards.

TI does not warrant or represent that any license, either express or implied, is granted under any TI patent right, copyright, mask work right, or other TI intellectual property right relating to any combination, machine, or process in which TI products or services are used. Information published by TI regarding third-party products or services does not constitute a license from TI to use such products or services or a warranty or endorsement thereof. Use of such information may require a license from a third party under the patents or other intellectual property of the third party, or a license from TI under the patents or other intellectual property of TI.

Reproduction of information in TI data books or data sheets is permissible only if reproduction is without alteration and is accompanied by all associated warranties, conditions, limitations, and notices. Reproduction of this information with alteration is an unfair and deceptive business practice. TI is not responsible or liable for such altered documentation.

Resale of TI products or services with statements different from or beyond the parameters stated by TI for that product or service voids all express and any implied warranties for the associated TI product or service and is an unfair and deceptive business practice. TI is not responsible or liable for any such statements.

Following are URLs where you can obtain information on other Texas Instruments products and application solutions:

Products		Applications	
Amplifiers	amplifier.ti.com	Audio	www.ti.com/audio
Data Converters	dataconverter.ti.com	Automotive	www.ti.com/automotive
DSP	dsp.ti.com	Broadband	www.ti.com/broadband
Interface	interface.ti.com	Digital Control	www.ti.com/digitalcontrol
Logic	logic.ti.com	Military	www.ti.com/military
Power Mgmt	power.ti.com	Optical Networking	www.ti.com/opticalnetwork
Microcontrollers	microcontroller.ti.com	Security	www.ti.com/security
		Telephony	www.ti.com/telephony
		Video & Imaging	www.ti.com/video
		Wireless	www.ti.com/wireless

Mailing Address: Texas Instruments
Post Office Box 655303 Dallas, Texas 75265