

INA137
INA2137

AUDIO DIFFERENTIAL LINE RECEIVERS

$\pm 6\text{dB}$ ($G = 1/2$ or 2)

FEATURES

- SINGLE AND DUAL VERSIONS
- LOW DISTORTION: 0.0005% at $f = 1\text{kHz}$
- HIGH SLEW RATE: $14\text{V}/\mu\text{s}$
- FAST SETTLING TIME: $3\mu\text{s}$ to 0.01%
- WIDE SUPPLY RANGE: $\pm 4\text{V}$ to $\pm 18\text{V}$
- LOW QUIESCENT CURRENT: 2.9mA max
- HIGH CMRR: 90dB
- FIXED GAIN = $\pm 6\text{dB}$
- PACKAGES—SINGLE: 8-PIN DIP, SO-8
DUAL: 14-PIN DIP, SO-14

DESCRIPTION

The INA137 and INA2137 are differential line receivers consisting of high performance op amps with on-chip precision resistors. They are fully specified for high performance audio applications and have excellent ac specifications, including low distortion (0.0005% at 1kHz) and high slew rate ($14\text{V}/\mu\text{s}$), assuring good dynamic response. In addition, wide output voltage swing and high output drive capability allow use in a wide variety of demanding applications. The dual version features completely independent circuitry for lowest crosstalk and freedom from interaction, even when overdriven or overloaded.

The INA137 and INA2137 on-chip resistors are laser trimmed for accurate gain and optimum common-mode rejection. Furthermore, excellent TCR tracking of the resistors maintains gain accuracy and common-mode rejection over temperature. Operation is guaranteed from $\pm 4\text{V}$ to $\pm 18\text{V}$ (8V to 36V total supply).

The INA137 is available in 8-pin DIP and SO-8 surface-mount packages. The INA2137 comes in 14-pin DIP and SO-14 surface-mount packages. Both are specified for operation over the extended industrial temperature range, -40°C to $+85^\circ\text{C}$.

APPLICATIONS

- AUDIO DIFFERENTIAL LINE RECEIVER
- $G = 1/2$ OR $G = 2$ AMPLIFIER
- INSTRUMENTATION BUILDING BLOCK
- CURRENT SHUNT MONITOR
- VOLTAGE-CONTROLLED CURRENT SOURCE
- GROUND LOOP ELIMINATOR

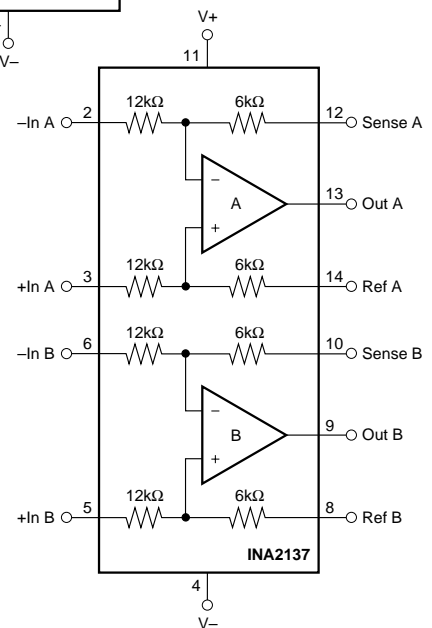
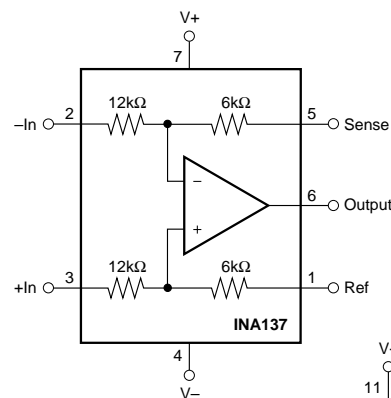

International Airport Industrial Park • Mailing Address: PO Box 11400, Tucson, AZ 85734 • Street Address: 6730 S. Tucson Blvd., Tucson, AZ 85706 • Tel: (520) 746-1111 • Twx: 910-952-1111
Internet: <http://www.burr-brown.com/> • FAXLine: (800) 548-6133 (US/Canada Only) • Cable: BBRCORP • Telex: 066-6491 • FAX: (520) 889-1510 • Immediate Product Info: (800) 548-6132

SPECIFICATIONS: $V_S = \pm 18V$

At $T_A = +25^\circ C$, $V_S = \pm 18V$, $R_L = 2k\Omega$, $G = 1/2$, and Ref Pin connected to Ground, unless otherwise noted.

PARAMETER	CONDITIONS	INA137PA, UA INA2137PA, UA			UNITS
		MIN	TYP	MAX	
AUDIO PERFORMANCE Total Harmonic Distortion + Noise, $f = 1\text{kHz}$ Noise Floor, RTO ⁽¹⁾ Headroom, RTO ⁽¹⁾	$V_{IN} = 10V_{rms}$ 20kHz BW THD+N < 1%		0.0005 -106 +23		% dBu dBu
FREQUENCY RESPONSE Small-Signal Bandwidth Slew Rate Settling Time: 0.1% 0.01% Overload Recovery Time Channel Separation (dual), $f = 1\text{kHz}$	10V Step, $C_L = 100pF$ 10V Step, $C_L = 100pF$ 50% Overdrive		4.0 14 2 3 3 123		MHz V/ μs μs μs μs dB
OUTPUT NOISE VOLTAGE ⁽²⁾ $f = 20\text{Hz}$ to 20kHz $f = 1\text{kHz}$			3.5 26		μV_{rms} nV/ \sqrt{Hz}
OFFSET VOLTAGE ⁽³⁾ Input Offset Voltage vs Temperature vs Power Supply	RTO $V_{CM} = 0V$ Specified Temperature Range $V_S = \pm 4V$ to $\pm 18V$		± 100 ± 2 ± 5	± 1000 ± 60	μV $\mu V/^\circ C$ $\mu V/V$
INPUT Common-Mode Voltage Range: Positive Negative Differential Voltage Range Common-Mode Rejection Impedance ⁽⁴⁾ Differential Common-Mode	$V_O = 0V$ $V_O = 0V$ $V_{CM} = \pm 46.5V$, $R_S = 0\Omega$	3(V+)-7.5 3(V-)+7.5 74	3(V+)-6 3(V-)+3 See Typical Curve 90 24 18		V V dB k Ω k Ω
GAIN Initial Error vs Temperature Nonlinearity	$V_O = -10V$ to $10V$ $V_O = -10V$ to $10V$		0.5 ± 0.01 ± 1 0.0001	± 0.1 ± 10	V/V % ppm/ $^\circ C$ %
OUTPUT Voltage Output, Positive Negative Current Limit, Continuous to Common Capacitive Load (Stable Operation)		(V+)-2 (V-)+2	(V+)-1.8 (V-)+1.6 ± 60 500		V V mA pF
POWER SUPPLY Rated Voltage Voltage Range Quiescent Current (per Amplifier)	 $I_O = 0$	± 4	± 18 ± 2.4	± 18 ± 2.9	V V mA
TEMPERATURE RANGE Specification Range Operation Range Storage Range Thermal Resistance, θ_{JA} 8-Pin DIP SO-8 Surface-Mount 14-Pin DIP SO-14 Surface-Mount		-40 -55 -55		85 125 125	$^\circ C$ $^\circ C$ $^\circ C$ $^\circ C/W$ $^\circ C/W$ $^\circ C/W$ $^\circ C/W$

RTO = Referred to Output.

NOTES: (1) dBu = 20log (Vrms/0.7746). (2) Includes effects of amplifier's input current noise and thermal noise contribution of resistor network. (3) Includes effects of amplifier's input bias and offset currents. (4) Internal resistors are ratio matched but have $\pm 25\%$ absolute value.

The information provided herein is believed to be reliable; however, BURR-BROWN assumes no responsibility for inaccuracies or omissions. BURR-BROWN assumes no responsibility for the use of this information, and all use of such information shall be entirely at the user's own risk. Prices and specifications are subject to change without notice. No patent rights or licenses to any of the circuits described herein are implied or granted to any third party. BURR-BROWN does not authorize or warrant any BURR-BROWN product for use in life support devices and/or systems.



PIN CONFIGURATIONS

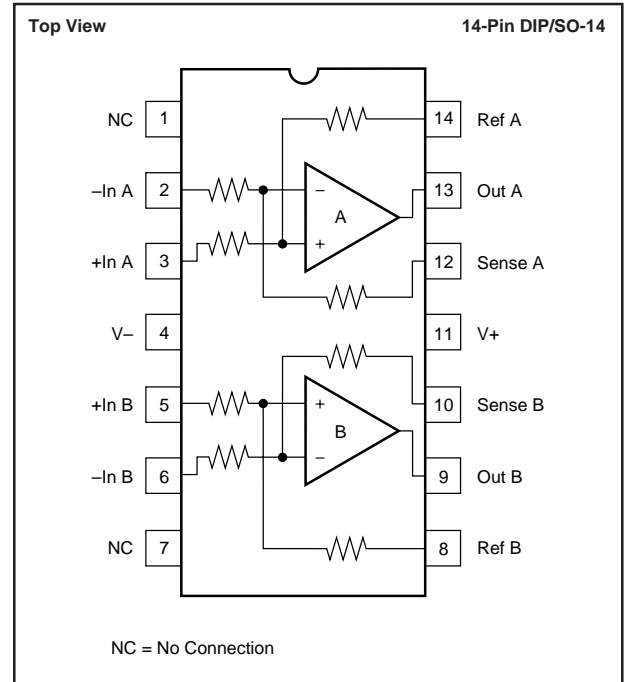
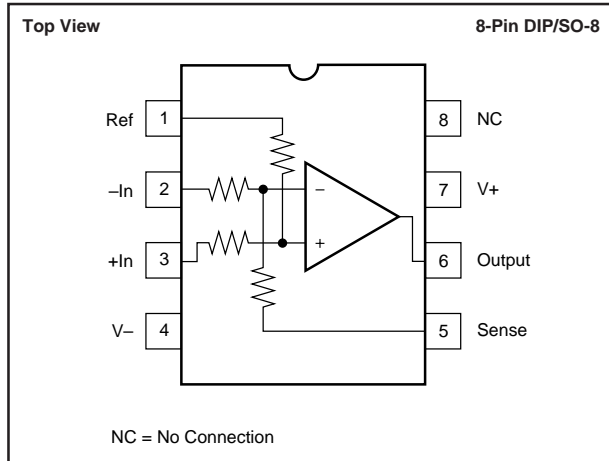

ABSOLUTE MAXIMUM RATINGS⁽¹⁾

Supply Voltage, V+ to V-	40V
Input Voltage Range	±80V
Output Short-Circuit (to ground) ⁽²⁾	Continuous
Operating Temperature	-55°C to +125°C
Storage Temperature	-55°C to +125°C
Junction Temperature	+150°C
Lead Temperature (soldering, 10s)	+300°C

NOTE: (1) Stresses above these ratings may cause permanent damage.
 (2) One channel per package.

PACKAGE/ORDERING INFORMATION

PRODUCT	PACKAGE	PACKAGE DRAWING NUMBER ⁽¹⁾	SPECIFICATION TEMPERATURE RANGE
Single			
INA137PA	8-Pin DIP	006	-40°C to +85°C
INA137UA	SO-8 Surface-Mount	182	-40°C to +85°C
Dual			
INA2137PA	14-Pin DIP	010	-40°C to +85°C
INA2137UA	SO-14 Surface-Mount	235	-40°C to +85°C

NOTE: (1) For detailed drawing and dimension table, please see end of data sheet, or Appendix C of Burr-Brown IC Data Book.

ELECTROSTATIC DISCHARGE SENSITIVITY

This integrated circuit can be damaged by ESD. Burr-Brown recommends that all integrated circuits be handled with appropriate precautions. Failure to observe proper handling and installation procedures can cause damage.

ESD damage can range from subtle performance degradation to complete device failure. Precision integrated circuits may be more susceptible to damage because very small parametric changes could cause the device not to meet its published specifications.

TYPICAL PERFORMANCE CURVES

At $T_A = +25^\circ\text{C}$, $V_S = \pm 18\text{V}$, and $G = 1/2$, unless otherwise noted.

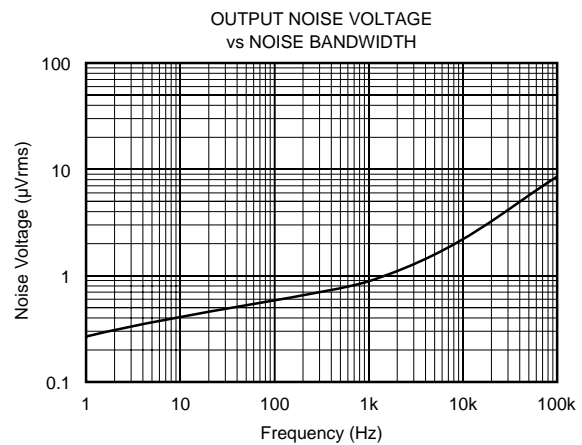
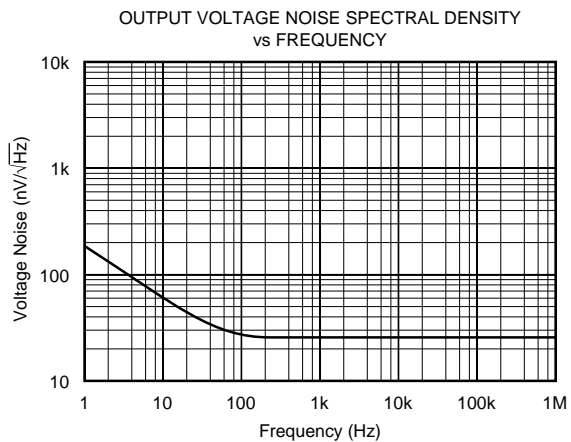
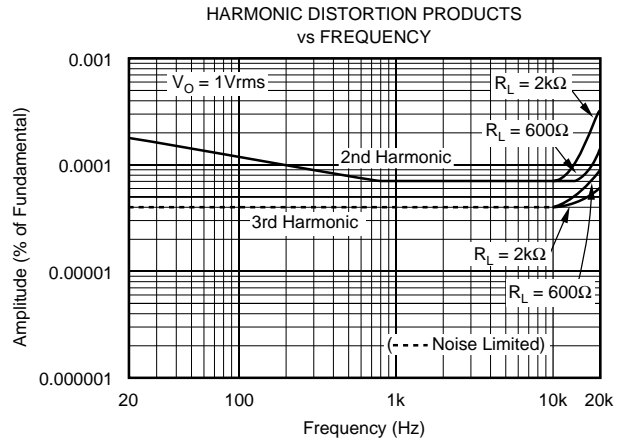
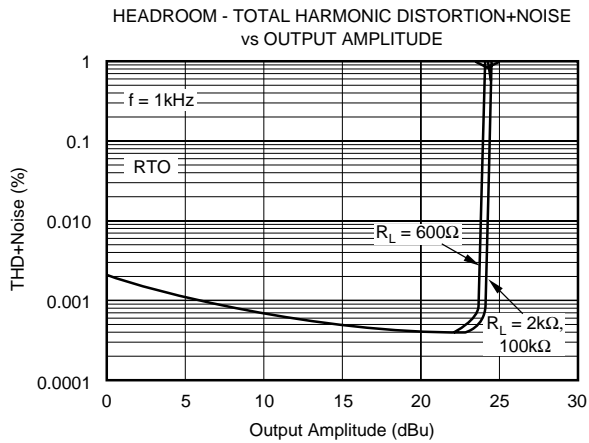
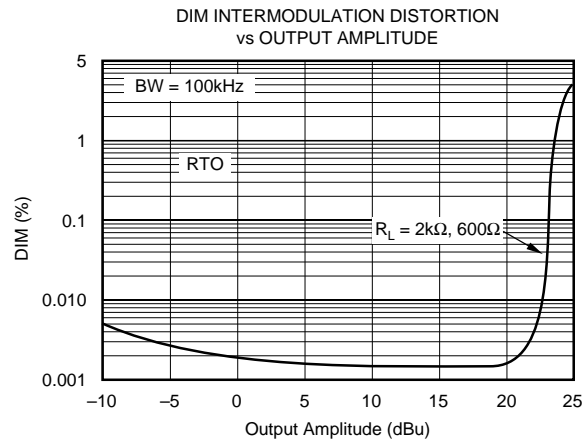
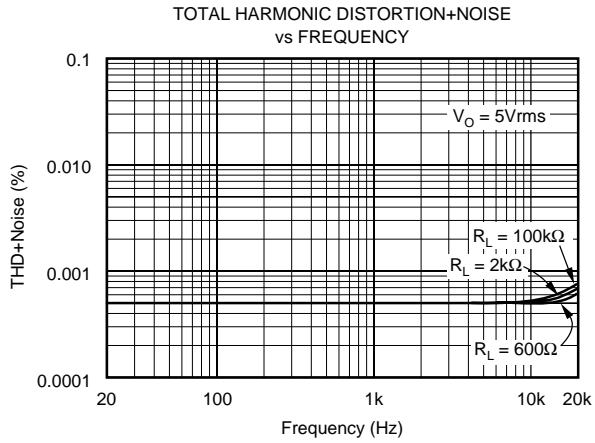

TYPICAL PERFORMANCE CURVES (CONT)

At $T_A = +25^\circ\text{C}$, $V_S = \pm 18\text{V}$, and $G = 1/2$, unless otherwise noted.

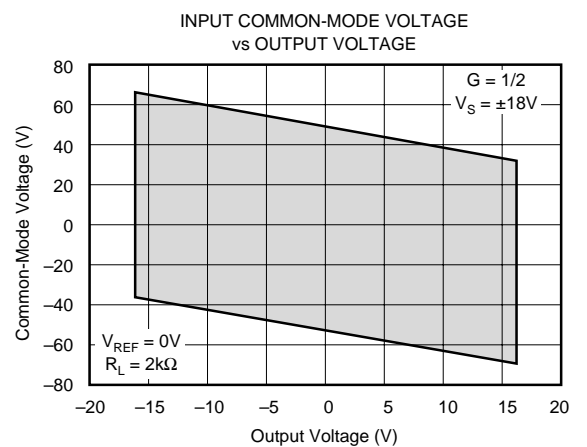
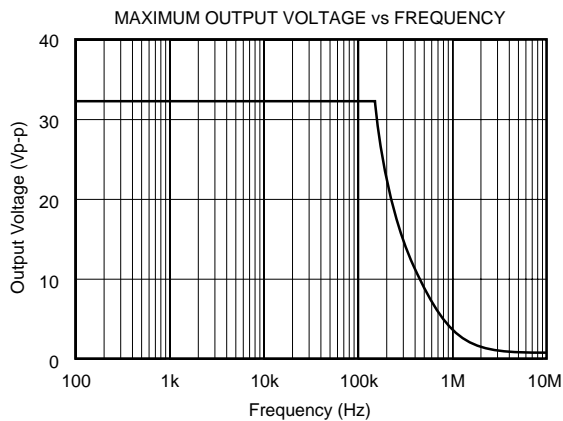
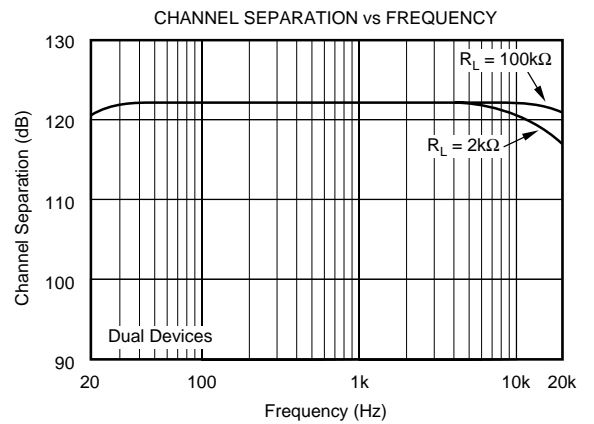
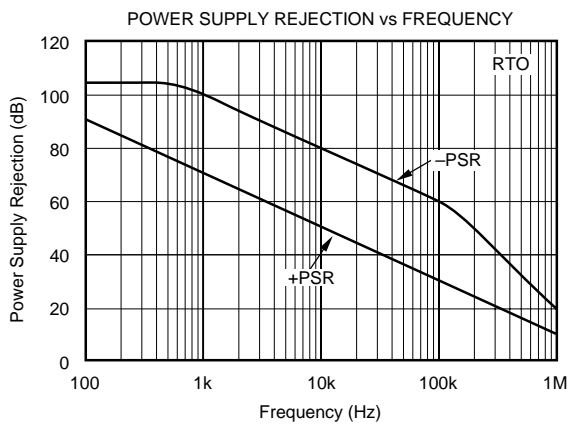
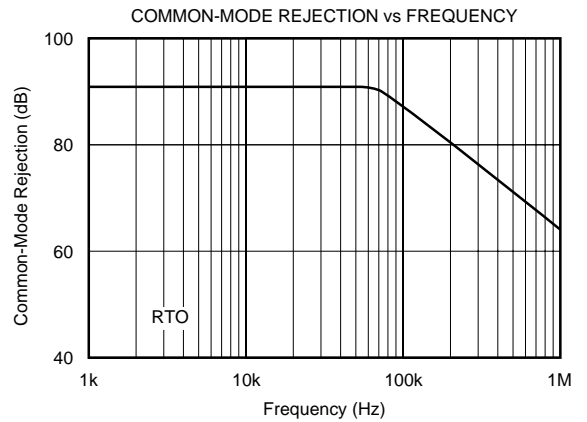
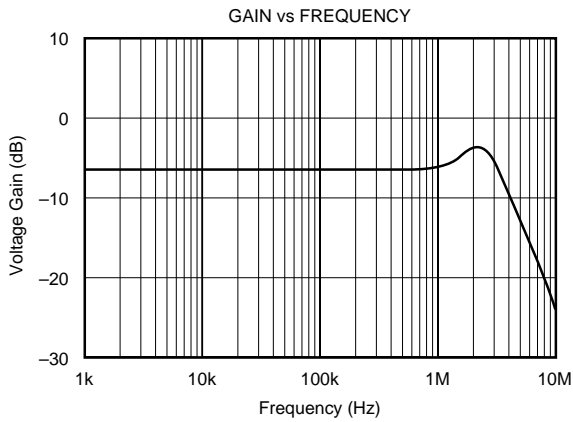

TYPICAL PERFORMANCE CURVES (CONT)

At $T_A = +25^\circ\text{C}$, $V_S = \pm 18\text{V}$, and $G = 1/2$, unless otherwise noted.

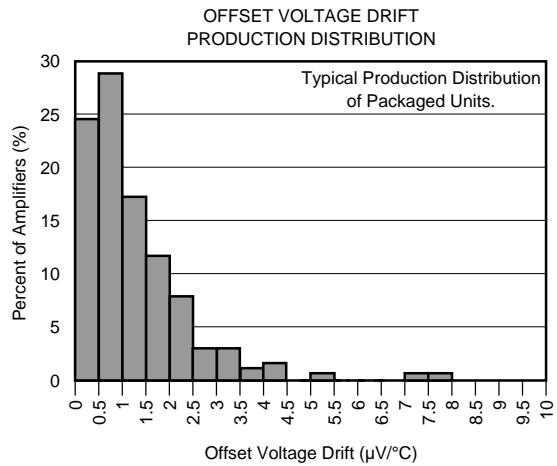
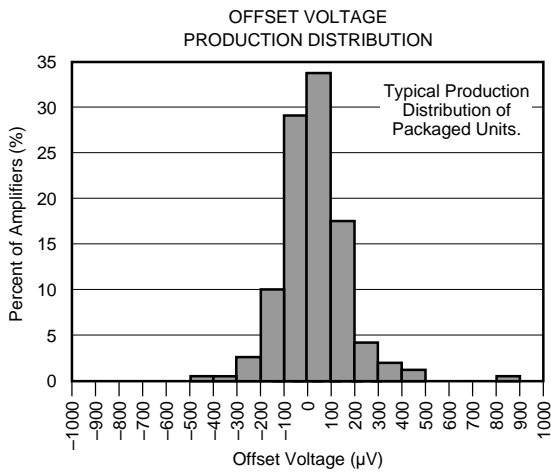
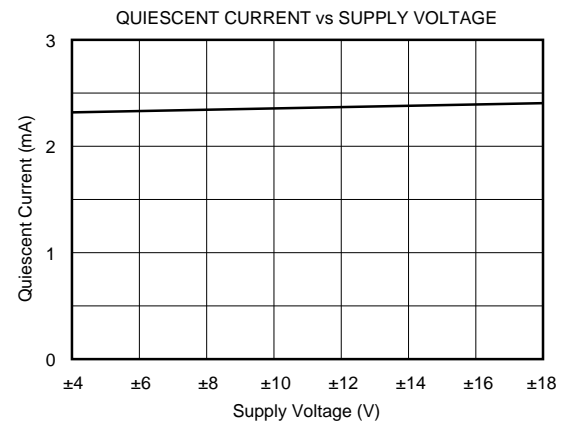
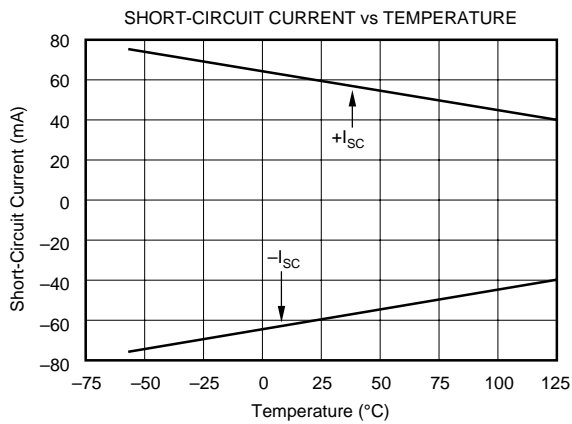
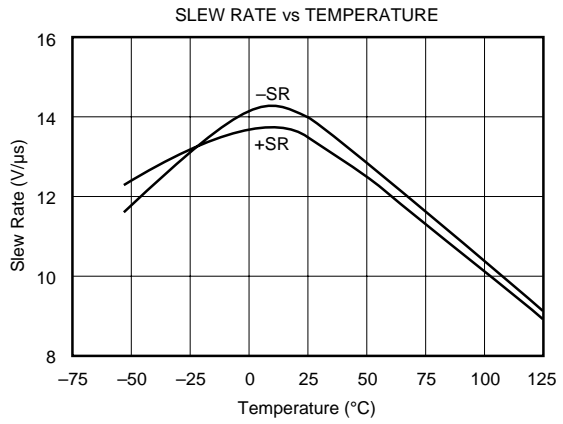
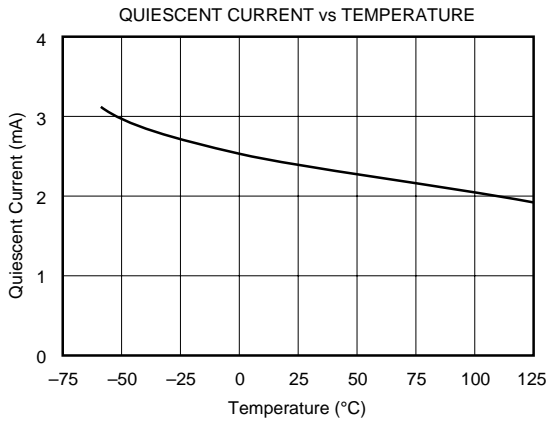

TYPICAL PERFORMANCE CURVES (CONT)

At $T_A = +25^\circ\text{C}$, $V_S = \pm 18\text{V}$, and $G = 1/2$, unless otherwise noted.

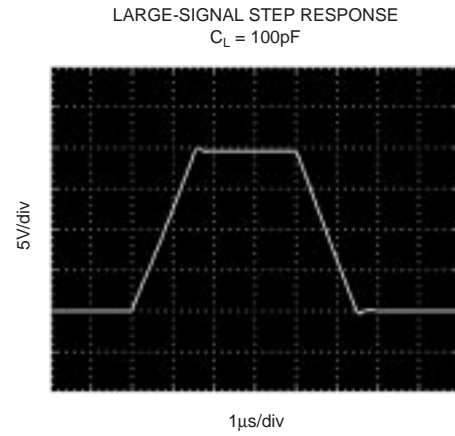
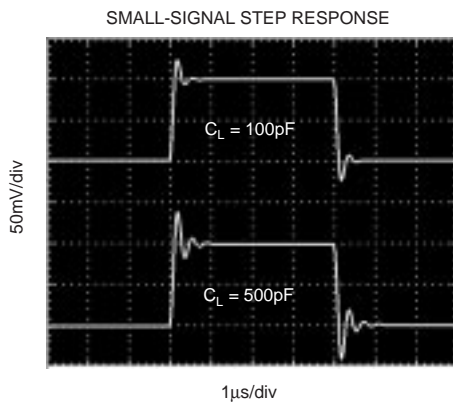
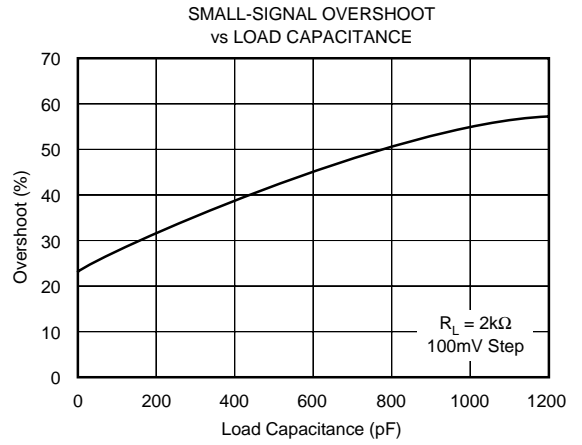
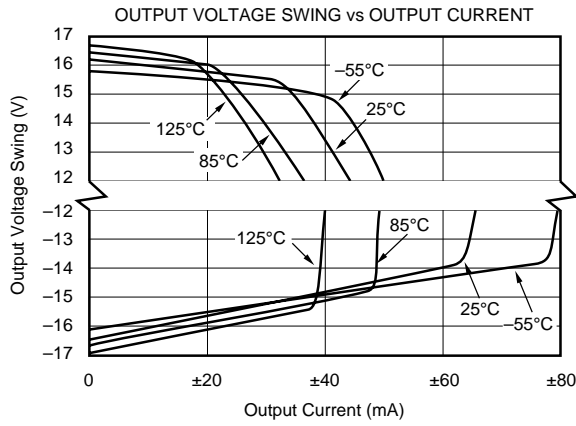

APPLICATIONS INFORMATION

The INA137 and INA2137 are differential line receivers suitable for a wide range of audio and general-purpose applications. Figure 1 shows the basic $G = 1/2$ (-6dB) differential receiver configuration. The input and feedback resistors can be reversed to achieve $G = 2$ ($+6\text{dB}$), as shown in Figure 2. For applications requiring $G = 1$ (0dB), the INA134 and INA2134 are recommended.

Decoupling capacitors are strongly recommended for applications with noisy or high impedance power supplies. The capacitors should be placed close to the device pins as shown in Figure 1. All circuitry is completely independent in the dual version assuring lowest crosstalk and normal behavior when one amplifier is overdriven or short-circuited.

As shown in Figure 1, the differential input signal is connected to pins 2 and 3. The source impedances connected to the inputs must be nearly equal to assure good common-mode rejection. A 5Ω mismatch in source impedance will degrade the common-mode rejection of a typical device to approximately 77dB (RTO). If the source has a known impedance mismatch, an additional resistor in series with the opposite input can be used to preserve good common-mode rejection.

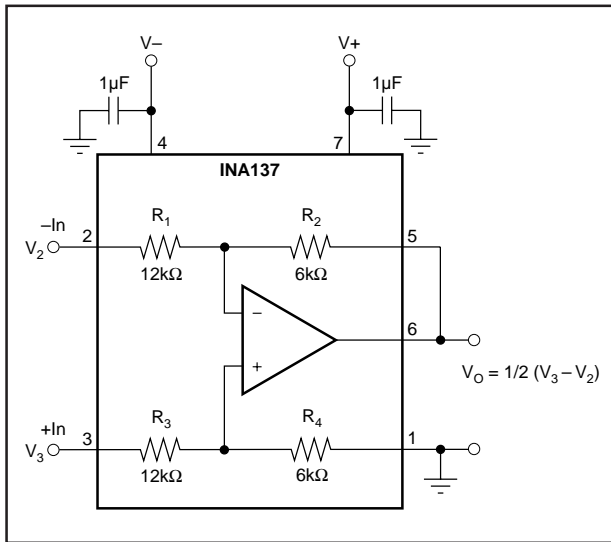

FIGURE 1. $G = 1/2$ Differential Receiver (Basic Power Supply and Signal Connections).

AUDIO PERFORMANCE

The INA137 and INA2137 were designed for enhanced ac performance. Very low distortion, low noise, and wide bandwidth provide superior performance in high quality audio applications. Laser-trimmed matched resistors provide optimum common-mode rejection (typically 90dB), especially when compared to circuits implemented with an op amp and discrete precision resistors. In addition, high slew rate ($14\text{V}/\mu\text{s}$) and fast settling time ($3\mu\text{s}$ to 0.01%) ensure excellent dynamic performance.

The INA137 and INA2137 have excellent distortion characteristics. $\text{THD} + \text{Noise}$ is below 0.001% throughout the audio frequency range. Up to approximately 10kHz distortion is below the measurement limit of commonly used test equipment. Furthermore, distortion remains relatively flat over its wide output voltage swing range (approximately 1.7V from either supply).

OFFSET VOLTAGE TRIM

The INA137 and INA2137 are laser trimmed for low offset voltage and drift. Most applications require no external offset adjustment. Figure 3 shows an optional circuit for trimming the output offset voltage. The output is referred to the output reference terminal (pin 1), which is normally grounded. A voltage applied to the Ref terminal will be summed with the output signal. This can be used to null offset voltage as shown in Figure 3. The source impedance of a signal applied to the Ref terminal should be less than 10Ω to maintain good common-mode rejection.

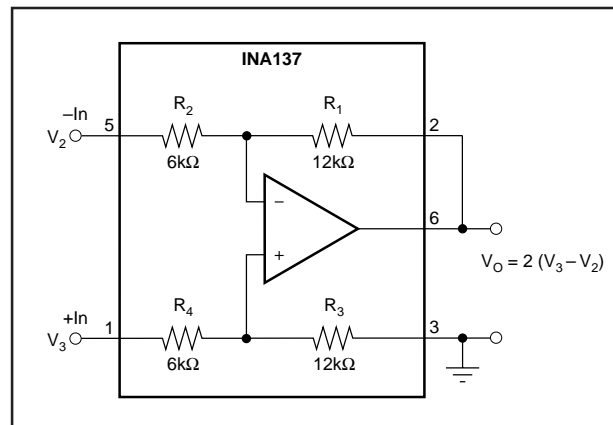

FIGURE 2. $G = 2$ Differential Receiver.

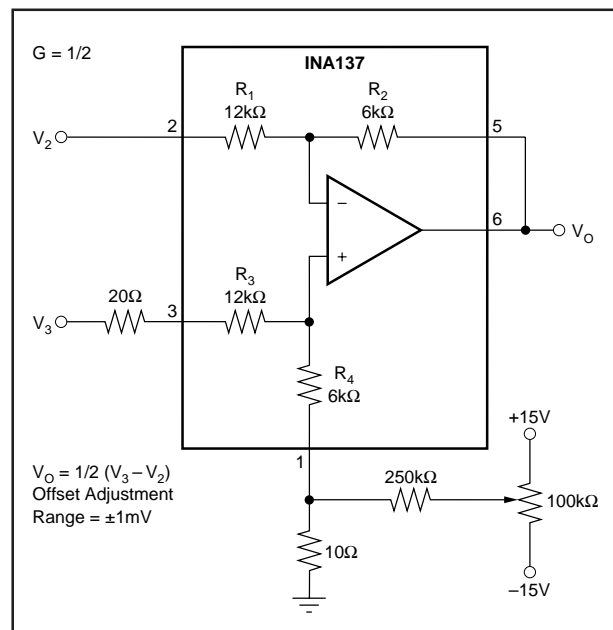

FIGURE 3. Offset Adjustment.

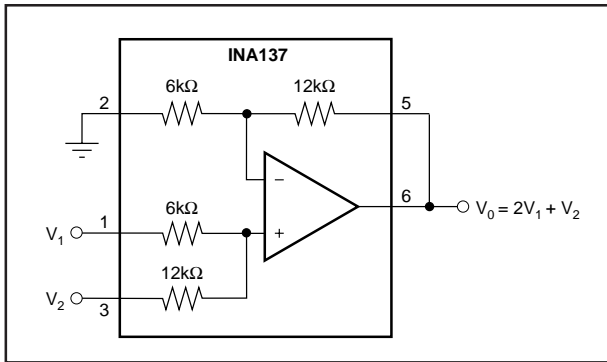

FIGURE 4. Precision Summing Amplifier.

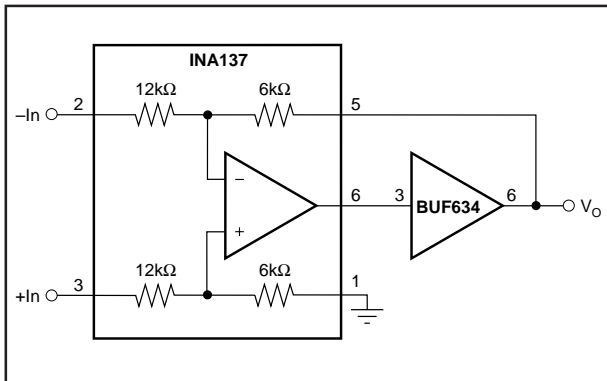

FIGURE 5. Boosting Output Current.

The difference amplifier is a highly versatile building block that is useful in a wide variety of applications. See the INA105 data sheet for additional applications ideas, including:

- Current Receiver with Compliance to Rails
- $\pm 10\text{V}$ Precision Voltage Reference
- $\pm 5\text{V}$ Precision Voltage Reference
- Precision Average Value Amplifier
- Precision Bipolar Offsetting
- Precision Summing Amplifier with Gain
- Instrumentation Amplifier Guard Drive Generator
- Precision Summing Instrumentation Amplifier
- Precision Absolute Value Buffer

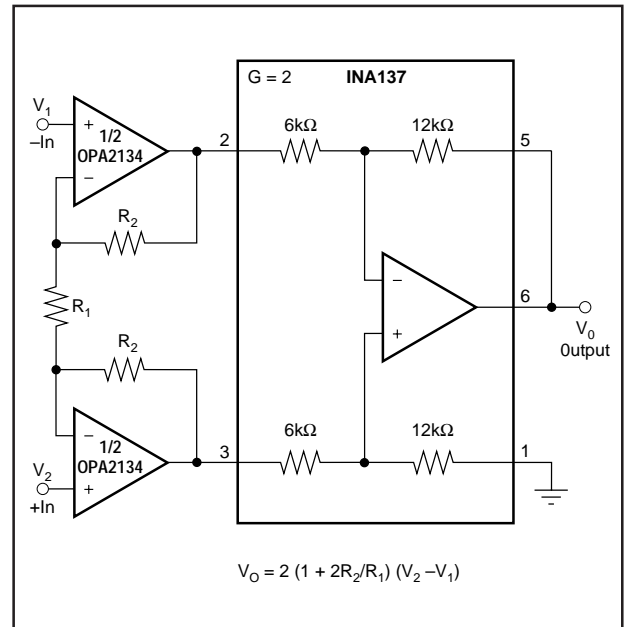

FIGURE 6. High Input Impedance Instrumentation Amplifier.

- Precision Voltage-to-Current Converter with Differential Inputs
- Differential Input Voltage-to-Current Converter for Low I_{OUT}
- Isolating Current Source
- Differential Output Difference Amplifier
- Isolating Current Source with Buffering Amplifier for Greater Accuracy
- Window Comparator with Window Span and Window Center Inputs
- Precision Voltage-Controlled Current Source with Buffered Differential Inputs and Gain

IMPORTANT NOTICE

Texas Instruments and its subsidiaries (TI) reserve the right to make changes to their products or to discontinue any product or service without notice, and advise customers to obtain the latest version of relevant information to verify, before placing orders, that information being relied on is current and complete. All products are sold subject to the terms and conditions of sale supplied at the time of order acknowledgment, including those pertaining to warranty, patent infringement, and limitation of liability.

TI warrants performance of its semiconductor products to the specifications applicable at the time of sale in accordance with TI's standard warranty. Testing and other quality control techniques are utilized to the extent TI deems necessary to support this warranty. Specific testing of all parameters of each device is not necessarily performed, except those mandated by government requirements.

Customers are responsible for their applications using TI components.

In order to minimize risks associated with the customer's applications, adequate design and operating safeguards must be provided by the customer to minimize inherent or procedural hazards.

TI assumes no liability for applications assistance or customer product design. TI does not warrant or represent that any license, either express or implied, is granted under any patent right, copyright, mask work right, or other intellectual property right of TI covering or relating to any combination, machine, or process in which such semiconductor products or services might be or are used. TI's publication of information regarding any third party's products or services does not constitute TI's approval, warranty or endorsement thereof.