

# INA143 INA2143

For most current data sheet and other product information, visit [www.burr-brown.com](http://www.burr-brown.com)

## High-Speed, Precision, $G = 10$ or $G = 0.1$ DIFFERENCE AMPLIFIERS

### FEATURES

- DESIGNED FOR LOW COST
- $G = 10V/V$  or  $G = 0.1V/V$
- SINGLE, DUAL VERSIONS
- LOW OFFSET VOLTAGE:  
 $\pm 250\mu V$  max,  $\pm 3\mu V/^\circ C$  max
- LOW GAIN ERROR: 0.01%
- HIGH SLEW RATE:  $5V/\mu s$
- FAST SETTLING TIME:  $9\mu s$  to 0.01%
- LOW QUIESCENT CURRENT:  $950\mu A$
- WIDE SUPPLY RANGE:  $\pm 2.25V$  to  $\pm 18V$
- SO-8 and SO-14 PACKAGES

### DESCRIPTION

The INA143 and INA2143 are high slew rate, gain of  $10V/V$  or  $0.1V/V$  difference amplifiers consisting of a precision op amp with a precision resistor network. The on-chip resistors are laser trimmed for accurate gain and high common-mode rejection. Excellent TCR tracking of the resistor maintains gain accuracy and common-mode rejection over temperature. They operate over a wide supply range,  $\pm 2.25V$  to  $\pm 18V$  ( $+4.5V$  to  $+36V$  single supply), and input common-mode voltage range extends beyond the positive and negative supply rails.

### APPLICATIONS

- DIFFERENTIAL INPUT AMPLIFIER BUILDING BLOCK
- DIFF IN/DIFF OUT AMPLIFIER
- GAIN =  $-10$  INVERTING AMPLIFIER
- GAIN =  $+10$  NON-INVERTING AMPLIFIER
- GAIN =  $+11$  NON-INVERTING AMPLIFIER
- SYNCHRONOUS DEMODULATOR
- CURRENT/DIFFERENTIAL LINE RECEIVER
- VOLTAGE-CONTROLLED CURRENT SOURCE
- BATTERY POWERED SYSTEMS
- LOW COST AUTOMOTIVE

The differential amplifier is the foundation of many commonly used circuits. The low cost INA143 and INA2143 provide this precision circuit function without using an expensive precision network.

The single version, INA143, package is the SO-8 surface mount. The dual version, INA2143, package is the SO-14 surface mount. Both are specified for operation over the extended industrial temperature range,  $-40^\circ C$  to  $+85^\circ C$ . Operation is from  $-55^\circ C$  to  $+125^\circ C$ .

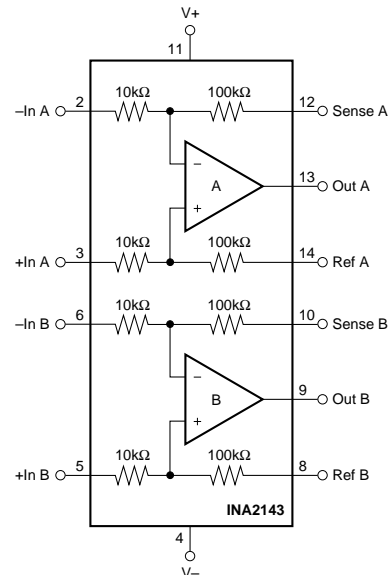
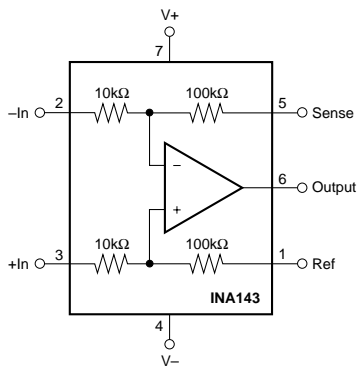

International Airport Industrial Park • Mailing Address: PO Box 11400, Tucson, AZ 85734 • Street Address: 6730 S. Tucson Blvd., Tucson, AZ 85706 • Tel: (520) 746-1111  
Twx: 910-952-1111 • Internet: <http://www.burr-brown.com/> • Cable: BBRCORP • Telex: 066-6491 • FAX: (520) 889-1510 • Immediate Product Info: (800) 548-6132

# SPECIFICATIONS: $V_S = \pm 15V$

At  $T_A = +25^\circ C$ ,  $V_S = \pm 15V$ ,  $G = 10$ ,  $R_L = 10k\Omega$  connected to ground, and reference pin connected to ground, unless otherwise noted.

PARAMETER	CONDITIONS	INA143U INA2143U			INA143UA INA2143UA			UNITS
		MIN	TYP	MAX	MIN	TYP	MAX	
<b>OFFSET VOLTAGE<sup>(1)</sup></b> Initial <sup>(1)</sup> vs Temperature vs Power Supply vs Time Channel Separation (dual)	RTI $V_{CM} = 0V$  $V_S = \pm 2.25V$ to $\pm 18V$  dc		$\pm 100$ $\pm 1$ $\pm 5$ 0.2 140	$\pm 250$ $\pm 3$ $\pm 20$		*	$\pm 500$  $\pm 30$	$\mu V$ $\mu V/^\circ C$ $\mu V/V$ $\mu V/\sqrt{mo}$ dB
<b>INPUT IMPEDANCE<sup>(3)</sup></b> Differential Common-Mode			20 55			*	*	k $\Omega$ k $\Omega$
<b>INPUT VOLTAGE RANGE</b> Common-Mode Voltage Range Positive Negative Common-Mode Rejection Ratio	RTI  $V_O = 0V$ $V_O = 0V$ $V_{CM} = -14.85V$ to $14.85V$ , $R_S = 0\Omega$		1.1[(V+)-1.5] 1.1[(V-)+1.5] 86	1.1[(V+)-1] 1.1[(V-)+1] 96		*	*	V V dB
<b>OUTPUT VOLTAGE NOISE<sup>(3)</sup></b> f = 0.1Hz to 10Hz f = 10Hz f = 100Hz f = 1kHz	RTI		1 45 30 27			*	*	$\mu Vp-p$ nV/ $\sqrt{Hz}$ nV/ $\sqrt{Hz}$ nV/ $\sqrt{Hz}$
<b>GAIN</b> Initial Error vs Temperature Nonlinearity	 $V_O = -14V$ to $+13.5V$  $V_O = -14V$ to $+13.5V$		10 $\pm 0.01$ $\pm 1$ $\pm 0.0001$	$\pm 0.05$ $\pm 10$ $\pm 0.001$		*	*	V/V % ppm/ $^\circ C$ % of FS
<b>OUTPUT</b> Voltage Output Positive Negative Positive Negative Current Limit Capacitive Load (stable operation)	Gain Error < 0.1% $R_L = 10k\Omega$ to Ground $R_L = 10k\Omega$ to Ground $R_L = 100k\Omega$ to Ground $R_L = 100k\Omega$ to Ground Continuous-to-Common	(V+) -1.5 (V-) +1	(V+) -1.3 (V-) +0.8 (V+) -0.8 (V-) +0.3 -25, +32 1000			*	*	V V V V mA pF
<b>FREQUENCY RESPONSE</b> Small-Signal Bandwidth Slew Rate Settling Time: 0.1% 0.01% Overload Recovery Time	-3dB  $V_O = 10V$ Step, $C_L = 100pF$ $V_O = 10V$ Step, $C_L = 100pF$ 50% Overdrive		0.15 5 6 9 6			*	*	MHz V/ $\mu s$ $\mu s$ $\mu s$ $\mu s$
<b>POWER SUPPLY</b> Rated Voltage Operating Voltage Range Dual Supplies Single Supply Quiescent Current (per amplifier)	   $I_O = 0$		$\pm 15$  $\pm 2.25$ +4.5  $\pm 0.95$	$\pm 18$  +36 $\pm 1.2$		*	*	V V V mA
<b>TEMPERATURE RANGE</b> Specification Operation Storage Thermal Resistance SO-8 Surface Mount SO-14 Surface Mount	   $\theta_{JA}$		-40 -55 -55  150 100	+85 +125 +125		*	*	$^\circ C$ $^\circ C$ $^\circ C$ $^\circ C/W$ $^\circ C/W$

\* Specifications the same as INA143U, INA2143U.

NOTES: (1) Includes the effects of amplifier's input bias and offset currents. (2) Internal resistors are ratio matched but have  $\pm 20\%$  absolute value. (3) Includes effects of amplifier's input current noise and thermal noise contribution of resistor network.

The information provided herein is believed to be reliable; however, BURR-BROWN assumes no responsibility for inaccuracies or omissions. BURR-BROWN assumes no responsibility for the use of this information, and all use of such information shall be entirely at the user's own risk. Prices and specifications are subject to change without notice. No patent rights or licenses to any of the circuits described herein are implied or granted to any third party. BURR-BROWN does not authorize or warrant any BURR-BROWN product for use in life support devices and/or systems.

# SPECIFICATIONS: $V_S = \pm 5V$

At  $T_A = +25^\circ C$ ,  $V_S = \pm 5V$ ,  $G = 10$ ,  $R_L = 10k\Omega$  connected to ground, and reference pin connected to ground, unless otherwise noted.

PARAMETER	CONDITIONS	INA143U INA2143U			INA143UA INA2143UA			UNITS
		MIN	TYP	MAX	MIN	TYP	MAX	
<b>OFFSET VOLTAGE<sup>(1)</sup></b> Initial <sup>(1)</sup> vs Temperature	RTI $V_{CM} = 0V$		$\pm 200$ $\pm 1$	$\pm 500$		*	$\pm 750$	$\mu V$ $\mu V/^\circ C$
<b>INPUT VOLTAGE RANGE</b> Common-Mode Voltage Range Positive Negative Common-Mode Rejection Ratio	RTI $V_O = 0V$ $V_O = 0V$ $V_{CM} = -3.85V$ to $+3.85V$ , $R_S = 0\Omega$	$1.1[(V+) - 1.5]$ $1.1[(V-) + 1.5]$ 86	$1.1[(V+) - 1]$ $1.1[(V-) + 1]$ 96		*	*		V V dB
<b>GAIN</b> Initial Gain Error Nonlinearity	$V_O = -4V$ to $+3.5V$ $V_O = -4V$ to $+3.5V$		10 $\pm 0.01$ $\pm 0.0001$	$\pm 0.05$ $\pm 0.001$		*	$\pm 0.1$ $\pm 0.002$	V/V % % of FS
<b>OUTPUT</b> Voltage Output Positive Negative Positive Negative	Gain Error < 0.1% $R_L = 10k\Omega$ to Ground $R_L = 10k\Omega$ to Ground $R_L = 100k\Omega$ to Ground $R_L = 100k\Omega$ to Ground	(V+) -1.5 (V-) +1	(V+) -1.3 (V-) +0.8 (V+) -0.8 (V-) +0.3		*	*		V V V V
<b>POWER SUPPLY</b> Rated Voltage Operating Voltage Range Dual Supplies Single Supply Quiescent Current (per amplifier)	$I_O = 0$		+5 $\pm 2.25$ +4.5	$\pm 18$ +36 $\pm 1.2$		*	*	V V V mA

\* Specifications the same as INA143U, INA2143U.

NOTES: (1) Includes the effects of amplifier's input bias and offset currents.

## ABSOLUTE MAXIMUM RATINGS<sup>(1)</sup>

Supply Voltage, $V+$ to $V-$ .....	36V
Input Signal ( $G = 10$ ), Voltage .....	$1.1 \cdot V_S$
Current .....	0.5mA
Input Signal ( $G = 0.1$ ), Voltage .....	$11 \cdot V_S$
Current .....	0.5mA
Output Short-Circuit (to ground) <sup>(2)</sup> .....	Continuous
Operating Temperature .....	$-55^\circ C$ to $+125^\circ C$
Storage Temperature .....	$-55^\circ C$ to $+125^\circ C$
Junction Temperature .....	$+150^\circ C$
Lead Temperature (soldering, 10s) .....	$+300^\circ C$

NOTES: (1) Stresses above these ratings may cause permanent damage. Exposure to absolute maximum conditions for extended periods may degrade device reliability. (2) One channel per package.

## ELECTROSTATIC DISCHARGE SENSITIVITY

This integrated circuit can be damaged by ESD. Burr-Brown recommends that all integrated circuits be handled with appropriate precautions. Failure to observe proper handling and installation procedures can cause damage.

ESD damage can range from subtle performance degradation to complete device failure. Precision integrated circuits may be more susceptible to damage because very small parametric changes could cause the device not to meet its published specifications.

## PACKAGE/ORDERING INFORMATION

PRODUCT	PACKAGE	PACKAGE DRAWING NUMBER <sup>(1)</sup>	SPECIFIED TEMPERATURE RANGE	PACKAGE MARKING	ORDERING NUMBER <sup>(2)</sup>	TRANSPORT MEDIA
<b>Single</b>						
INA143U	SO-8 Surface Mount	182	$-40^\circ C$ to $+85^\circ C$	INA143U	INA143U	Rails
"	"	"	"	"	INA143U/2K5	Tape and Reel
INA143UA	SO-8 Surface Mount	182	$-40^\circ C$ to $+85^\circ C$	INA143UA	INA143UA	Rails
"	"	"	"	"	INA143UA/2K5	Tape and Reel
<b>Dual</b>						
INA2143U	SO-14 Surface Mount	235	$-40^\circ C$ to $+85^\circ C$	INA2143U	INA2143U	Rails
"	"	"	"	"	INA2143U/2K5	Tape and Reel
INA2143UA	SO-14 Surface Mount	235	$-40^\circ C$ to $+85^\circ C$	INA2143UA	INA2143UA	Rails
"	"	"	"	"	INA2143UA/2K5	Tape and Reel

NOTES: (1) For detailed drawing and dimension table, please see end of data sheet, or Appendix C of Burr-Brown IC Data Book. (2) Models with a slash (/) are available only in Tape and Reel in the quantities indicated (e.g., /2K5 indicates 2500 devices per reel). Ordering 2500 pieces of "INA143UA/2K5" will get a single 2500-piece Tape and Reel. For detailed Tape and Reel mechanical information, refer to Appendix B of Burr-Brown IC Data Book.

# PIN CONFIGURATIONS

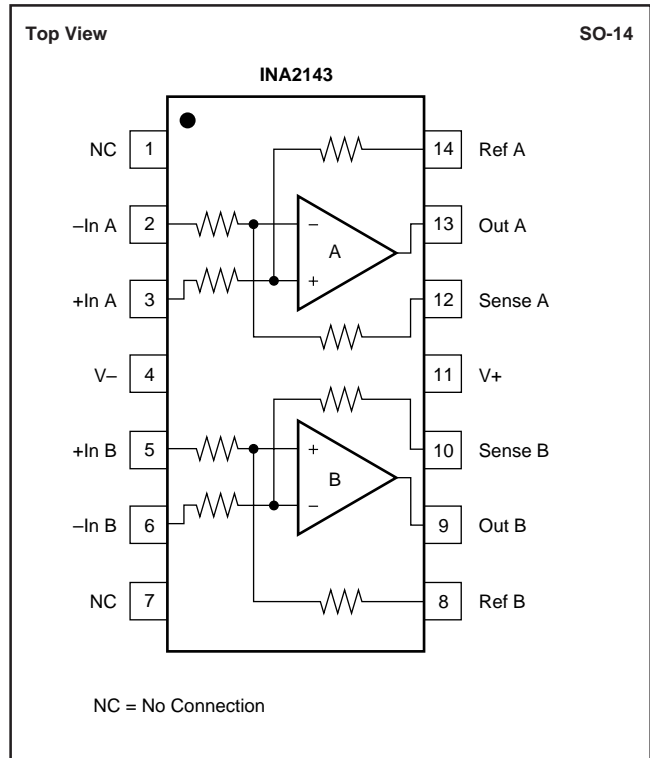
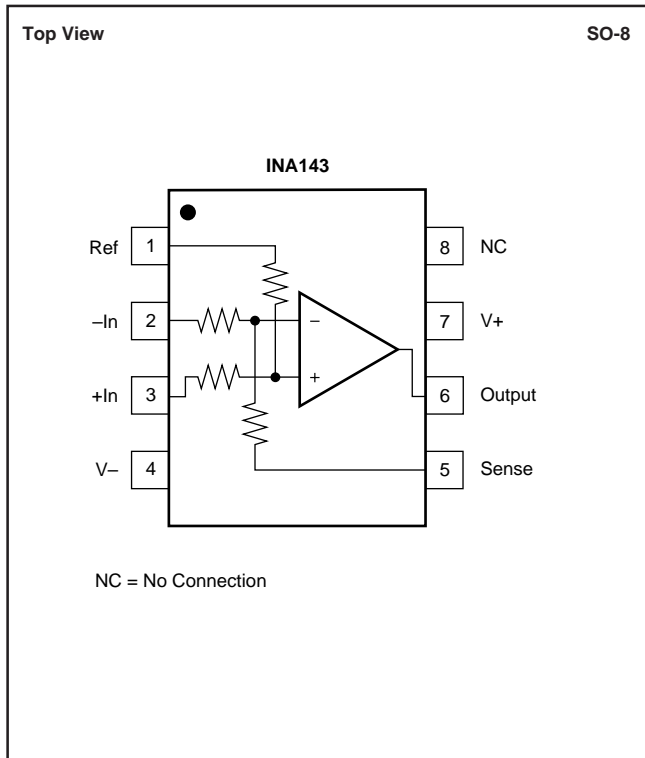

# TYPICAL PERFORMANCE CURVES

At  $T_A = +25^\circ\text{C}$ ,  $V_S = \pm 15\text{V}$ ,  $G = 10$ ,  $R_L = 10\text{k}\Omega$  connected to ground, and reference pin connected to ground, unless otherwise noted.

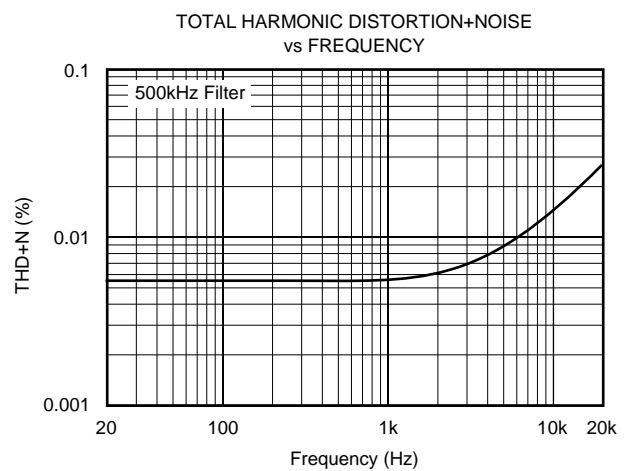
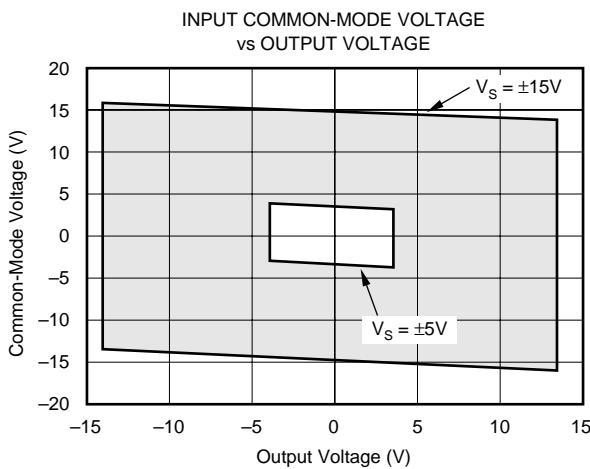
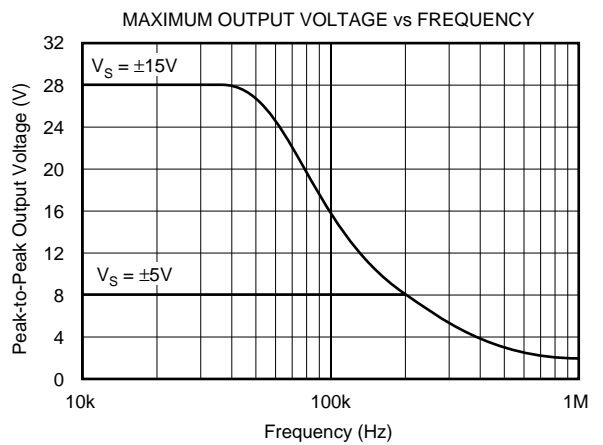
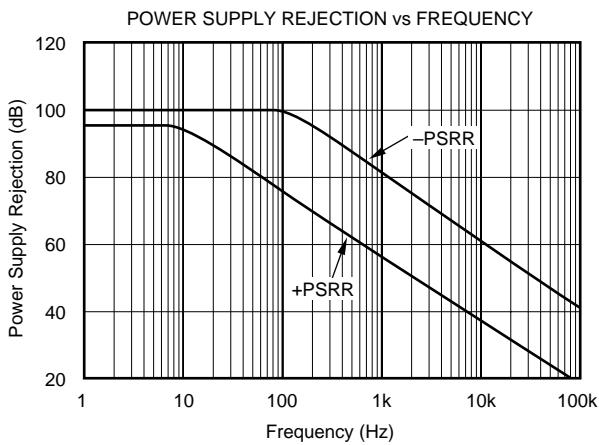
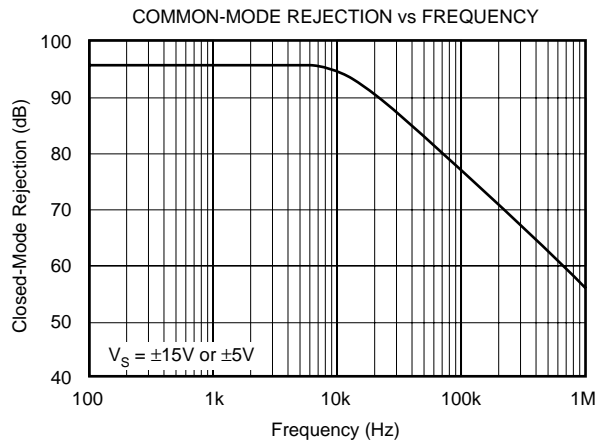
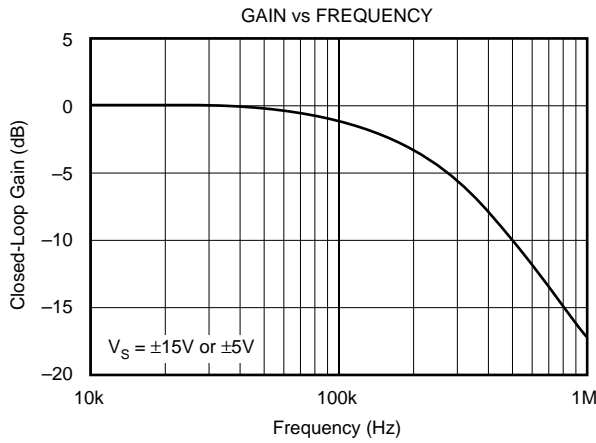

# TYPICAL PERFORMANCE CURVES (CONT)

At  $T_A = +25^\circ\text{C}$ ,  $V_S = \pm 15\text{V}$ ,  $G = 10$ ,  $R_L = 10\text{k}\Omega$  connected to ground, and reference pin connected to ground, unless otherwise noted.

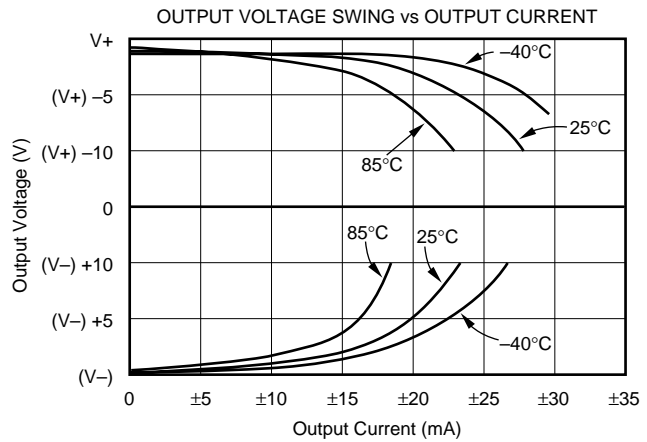
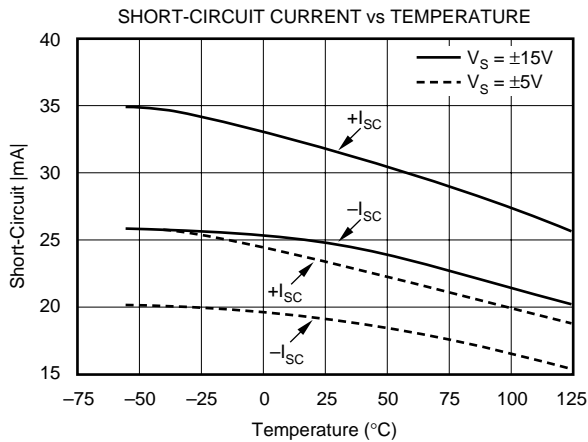
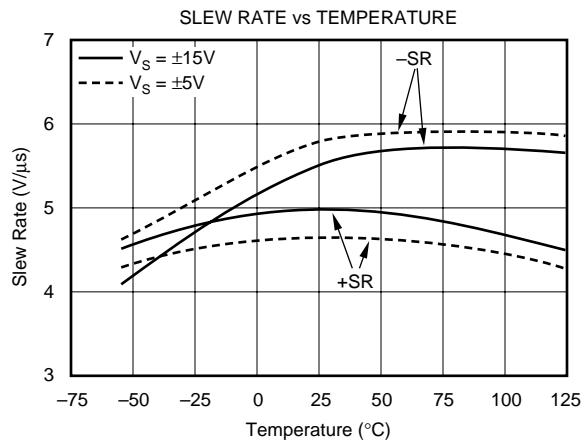
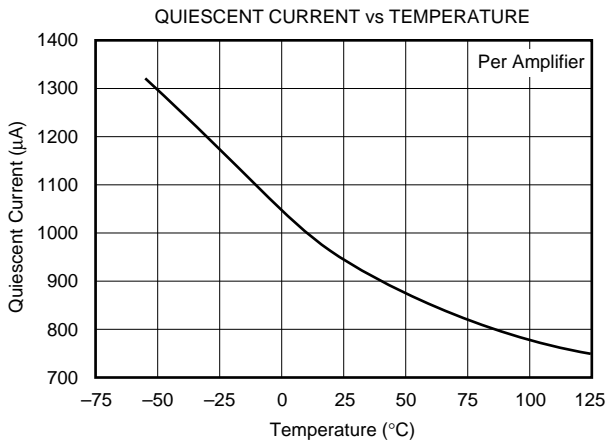
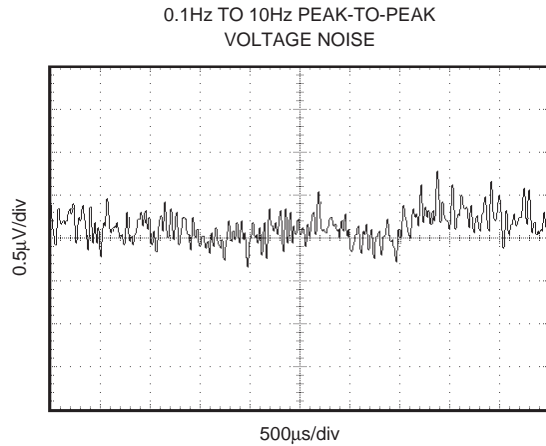
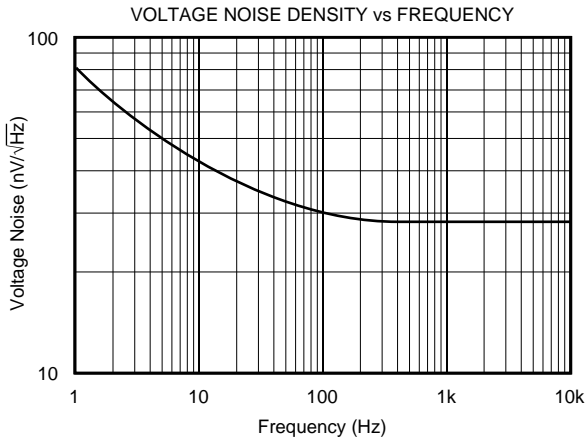

# TYPICAL PERFORMANCE CURVES (CONT)

At  $T_A = +25^\circ\text{C}$ ,  $V_S = \pm 15\text{V}$ ,  $G = 10$ ,  $R_L = 10\text{k}\Omega$  connected to ground, and reference pin connected to ground, unless otherwise noted.

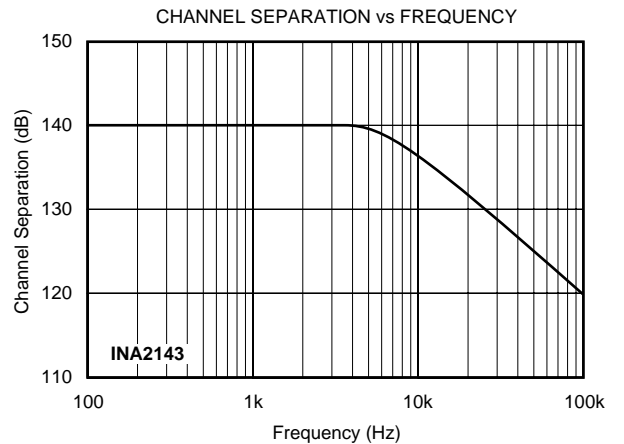
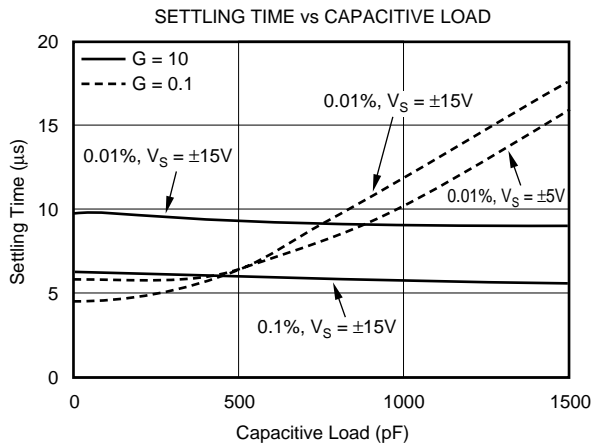
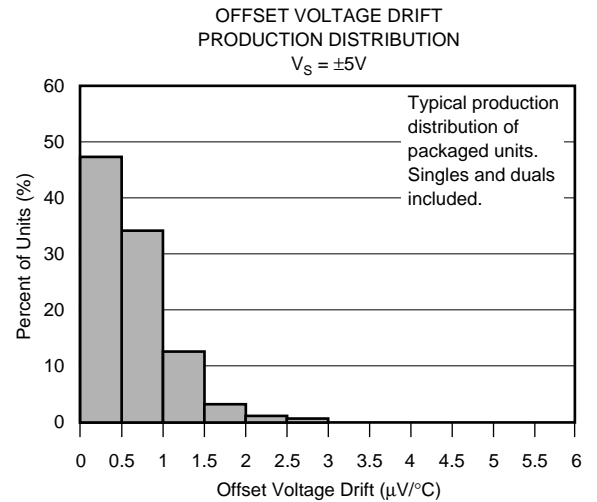
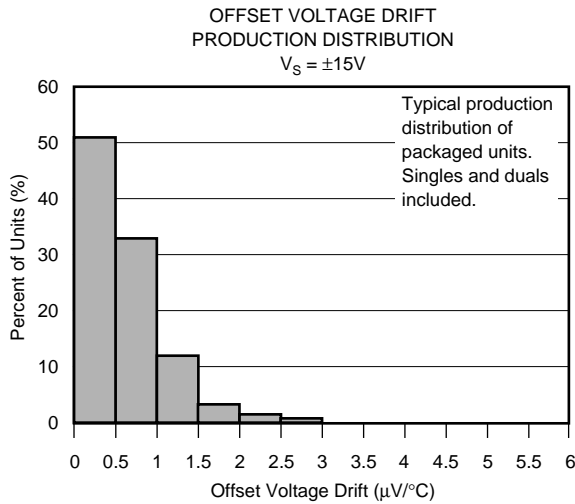
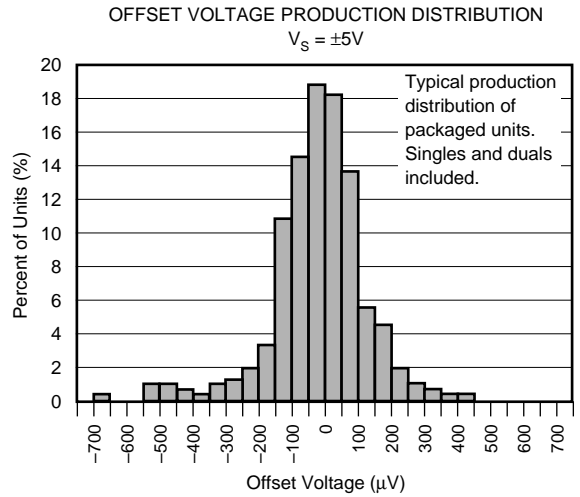
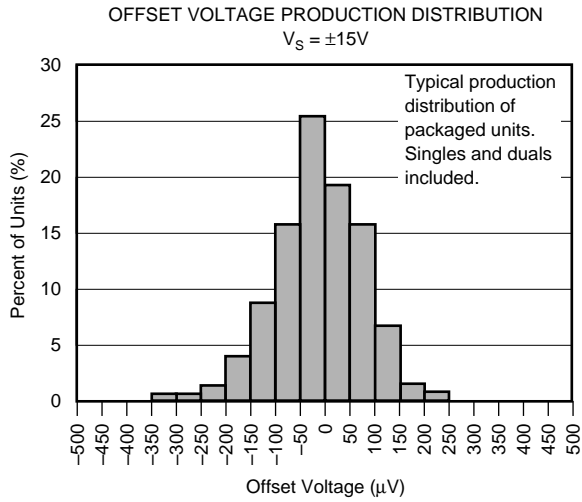

# TYPICAL PERFORMANCE CURVES (CONT)

At  $T_A = +25^\circ\text{C}$ ,  $V_S = \pm 15\text{V}$ ,  $G = 10$ ,  $R_L = 10\text{k}\Omega$  connected to ground, and reference pin connected to ground, unless otherwise noted.

SMALL-SIGNAL STEP RESPONSE

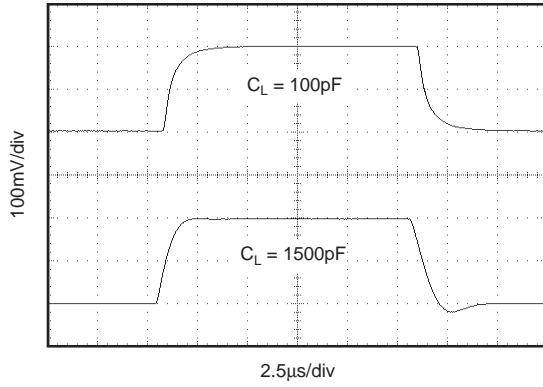

LARGE-SIGNAL STEP RESPONSE

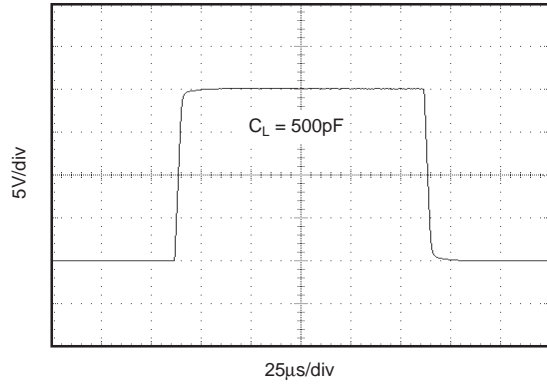

## APPLICATIONS INFORMATION

The INA143 and INA2143 are high-speed difference amplifiers suitable for a wide range of general-purpose applications. Figure 1 shows the basic  $G = 10$  configuration. The input and feedback resistors can be reversed to achieve  $G = 0.1$ , as shown in Figure 2. For applications requiring  $G = 1$ , the INA133 and INA2133 are recommended.

Decoupling capacitors are strongly recommended for applications with noisy or high impedance power supplies. The capacitors should be placed close to the device pins as shown in Figure 1. All circuitry is completely independent in the dual version assuring lowest crosstalk and normal behavior when one amplifier is overdriven or short-circuited.

As shown in Figure 1, the differential input signal is connected to pins 2 and 3. The source impedances connected to the inputs must be nearly equal to assure good common-mode rejection. A  $5\Omega$  mismatch in source impedance will degrade the common-mode rejection of a typical device to approximately 86dB (RTI). If the source has a known impedance mismatch, an additional resistor in series with the opposite input can be used to preserve good common-mode rejection.

The INA143's internal resistors are accurately ratio trimmed to match. That is,  $R_1/R_2$  and  $R_3/R_4$  are trimmed to equal 0.1. However, the absolute values may not be equal ( $R_1 + R_2$  may be slightly different than  $R_3 + R_4$ ). Thus, large series resistors on the input (greater than  $100\Omega$ ), even if well matched, will degrade common-mode rejection.

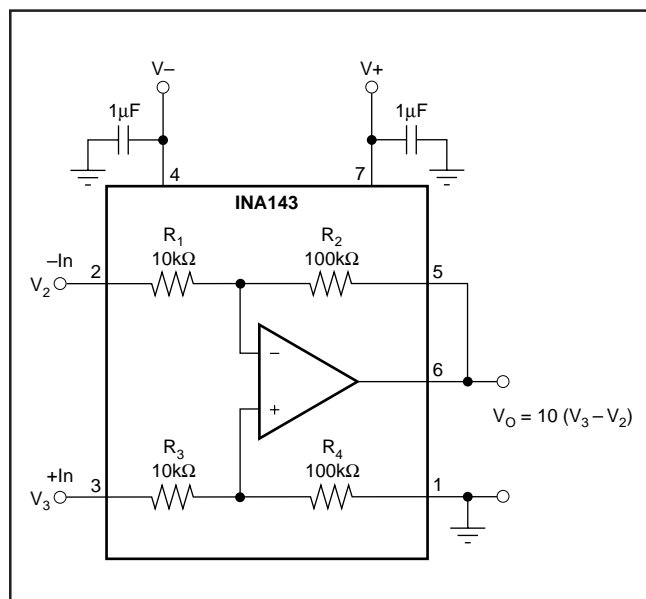

FIGURE 1.  $G = 10$  Basic Power Supply and Signal Connections.

### OPERATING VOLTAGE

The INA143 and INA2143 operate from single (+4.5V to +36V) or dual ( $\pm 2.25V$  to  $\pm 18V$ ) supplies with excellent performance. Specifications are production tested with  $\pm 5V$  and  $\pm 15V$  supplies. Most behavior remains unchanged

throughout the full operating voltage range. Parameters which vary significantly with operating voltage are shown in the Typical Performance Curves.

### OFFSET VOLTAGE TRIM

The INA143 and INA2143 are laser trimmed for low offset voltage and drift. Most applications require no external offset adjustment. Figure 3 shows an optional circuit for trimming the output offset voltage. The output is referred to the output reference terminal (pin 1), which is normally grounded. A voltage applied to the Ref terminal will be summed with the output signal. This can be used to null offset voltage as shown in Figure 3. The source impedance of a signal applied to the Ref terminal should be less than  $10\Omega$  to maintain good common-mode rejection.

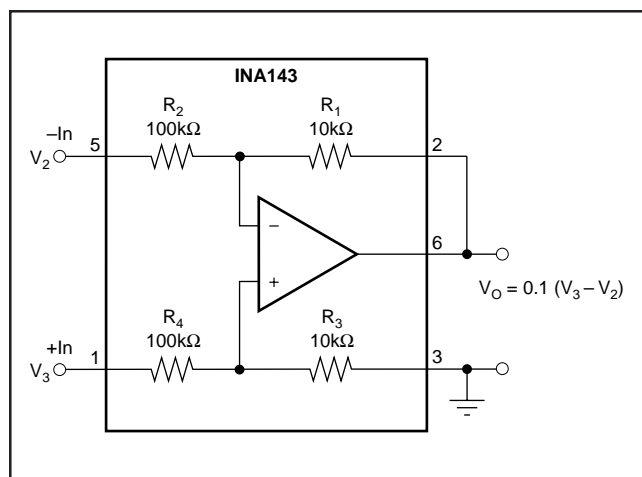

FIGURE 2.  $G = 0.1$  Difference Amplifier.

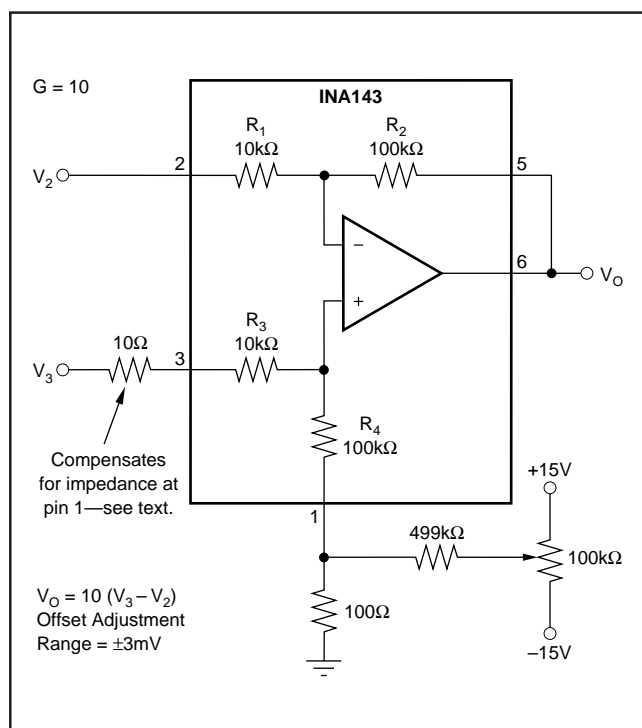

FIGURE 3. Offset Adjustment.

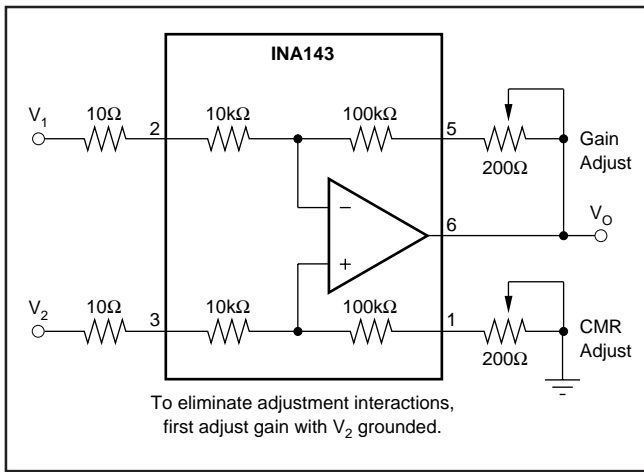

FIGURE 4. Difference Amplifier with Gain and CMR Adjust.

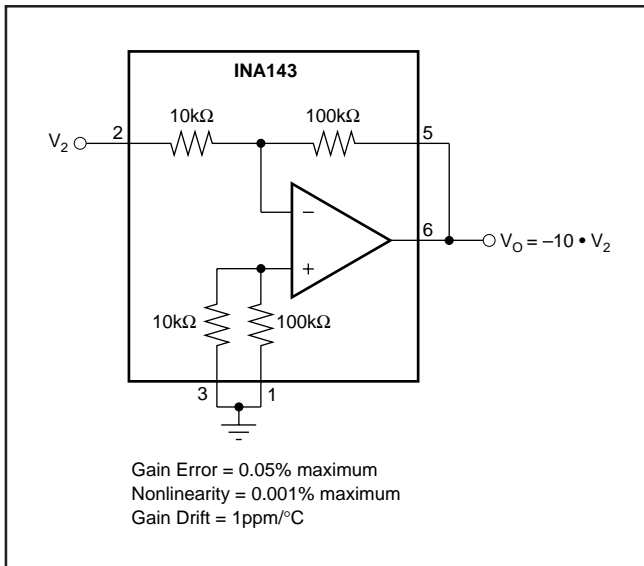

FIGURE 5. Precision  $G = -10$  Inverting Amplifier.

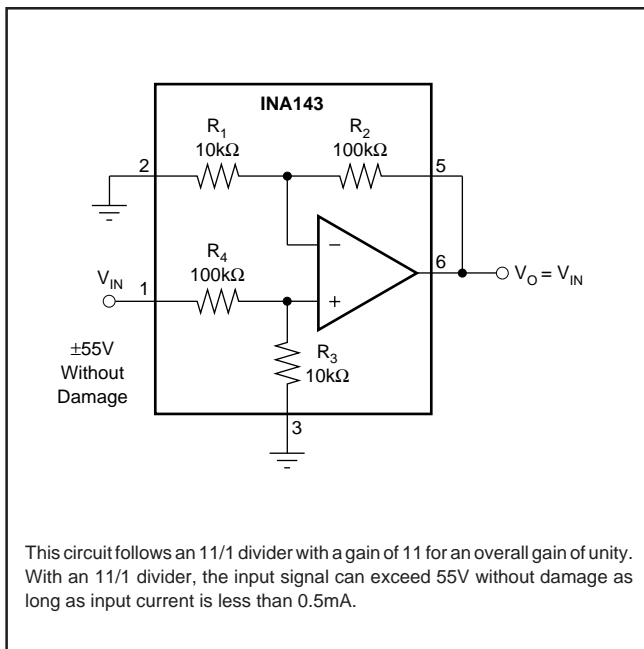
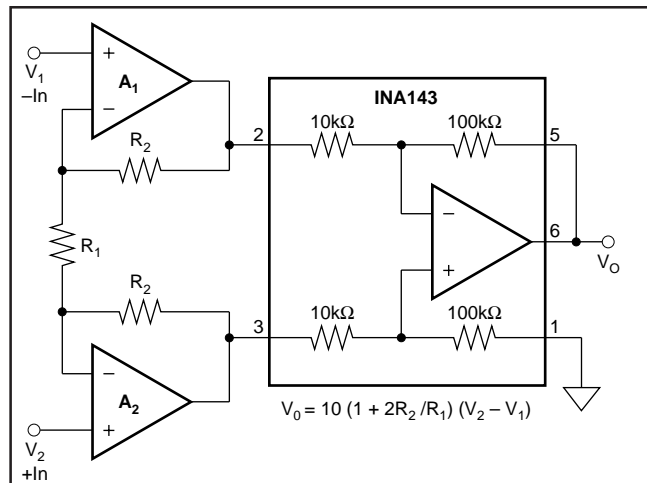

FIGURE 6. Voltage Follower with Input Protection.



The INA143 can be combined with op amps to form a complete instrumentation amplifier with specialized performance characteristics. Burr-Brown offers many complete high performance IAs. Products with related performances are shown at the right in the table below.

$A_1, A_2$	FEATURE	SIMILAR COMPLETE BURR-BROWN IA
OPA2227	Low Noise	INA103
OPA129	Ultra Low Bias Current (fA)	INA116
OPA2277	Low Offset Drift, Low Noise	INA114, INA128
OPA2130	Low Power, FET-Input (pA)	INA121
OPA2234	Single Supply, Precision, Low Power	INA122, INA118
OPA2237	Single Supply, Low Power, MSOP-8	INA122, INA126

FIGURE 7. Precision Instrumentation Amplifier.

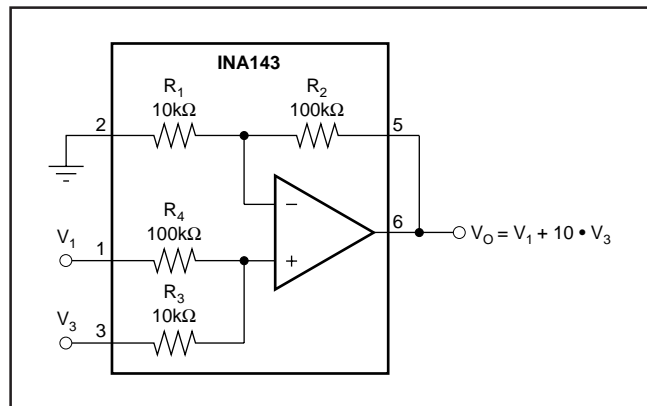

FIGURE 8. Precision Summing Amplifier.

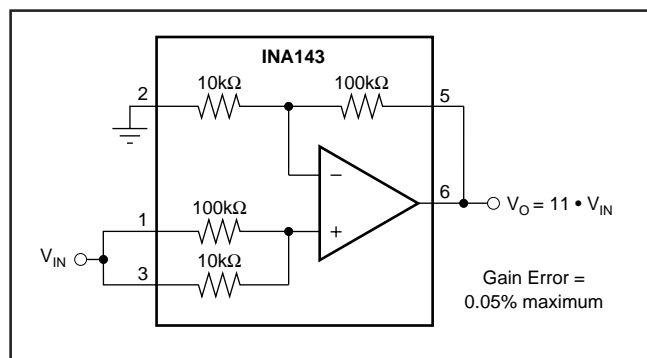

FIGURE 9. Precision  $G = 11$  Buffer.

## **IMPORTANT NOTICE**

Texas Instruments and its subsidiaries (TI) reserve the right to make changes to their products or to discontinue any product or service without notice, and advise customers to obtain the latest version of relevant information to verify, before placing orders, that information being relied on is current and complete. All products are sold subject to the terms and conditions of sale supplied at the time of order acknowledgment, including those pertaining to warranty, patent infringement, and limitation of liability.

TI warrants performance of its semiconductor products to the specifications applicable at the time of sale in accordance with TI's standard warranty. Testing and other quality control techniques are utilized to the extent TI deems necessary to support this warranty. Specific testing of all parameters of each device is not necessarily performed, except those mandated by government requirements.

Customers are responsible for their applications using TI components.

In order to minimize risks associated with the customer's applications, adequate design and operating safeguards must be provided by the customer to minimize inherent or procedural hazards.

TI assumes no liability for applications assistance or customer product design. TI does not warrant or represent that any license, either express or implied, is granted under any patent right, copyright, mask work right, or other intellectual property right of TI covering or relating to any combination, machine, or process in which such semiconductor products or services might be or are used. TI's publication of information regarding any third party's products or services does not constitute TI's approval, warranty or endorsement thereof.