



Low-Noise, Low-Distortion INSTRUMENTATION AMPLIFIER Replacement for SSM2017

FEATURES

- **LOW NOISE:** 1.3nV/ $\sqrt{\text{Hz}}$ at 1kHz
- **LOW THD+N:** 0.004% at 1kHz, $G = 100$
- **WIDE BANDWIDTH:** 800kHz at $G = 100$
- **WIDE SUPPLY RANGE:** $\pm 4.5\text{V}$ to $\pm 18\text{V}$
- **HIGH CMR:** > 100dB
- **GAIN SET WITH EXTERNAL RESISTOR**
- **DIP-8 AND SOL-16 WIDEBODY PACKAGES**

APPLICATIONS

- **PROFESSIONAL MICROPHONE PREAMPS**
- **MOVING-COIL TRANSDUCER AMPLIFIERS**
- **DIFFERENTIAL RECEIVERS**
- **BRIDGE TRANSDUCER AMPLIFIERS**

DESCRIPTION

The INA217 is a low-noise, low-distortion, monolithic instrumentation amplifier. Current-feedback circuitry allows the INA217 to achieve wide bandwidth and excellent dynamic response over a wide range of gain. The INA217 is ideal for low-level audio signals such as balanced low-impedance microphones. Many industrial, instrumentation, and medical applications also benefit from its low noise and wide bandwidth.

Unique distortion cancellation circuitry reduces distortion to extremely low levels, even in high gain. The INA217 provides near-theoretical noise performance for 200 Ω source impedance. The INA217 features differential input, low noise, and low distortion that provides superior performance in professional microphone amplifier applications.

The INA217 features wide supply voltage, excellent output voltage swing, and high output current drive making it an optimal candidate for use in high-level audio stages.

The INA217 is available in the same DIP-8 and SOL-16 wide body packages and pin outs as the SSM2017. For a smaller package, see the INA163 in SO-14 narrow. The INA217 is specified over the temperature range of -40°C to $+85^{\circ}\text{C}$.

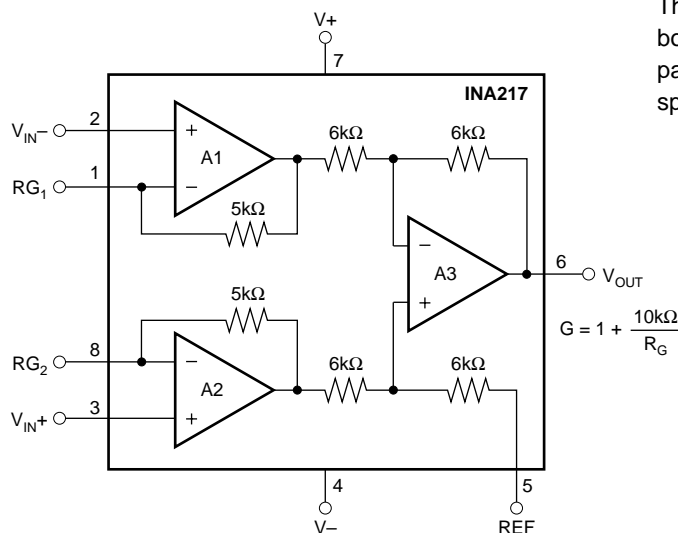

Please be aware that an important notice concerning availability, standard warranty, and use in critical applications of Texas Instruments semiconductor products and disclaimers thereto appears at the end of this data sheet.

ABSOLUTE MAXIMUM RATINGS⁽¹⁾

Supply Voltage, V+ to V-.....	±18V
Signal Input Terminals, Voltage ⁽²⁾	(V-) - 0.5V to (V+) + 0.5V
Current ⁽²⁾	10mA
Output Short-Circuit ⁽³⁾	Continuous
Operating Temperature.....	-55°C to +125°C
Storage Temperature.....	-55°C to +150°C
Junction Temperature.....	+150°C
Lead Temperature (soldering, 10s).....	+300°C

NOTES: (1) Stresses above these ratings may cause permanent damage. Exposure to absolute maximum conditions for extended periods may degrade device reliability. (2) Input terminals are diode-clamped to the power-supply rails. Input signals that can swing more than 0.5V beyond the supply rails should be current limited to 10mA or less. (3) Short-circuit to ground, one amplifier per package.

ELECTROSTATIC DISCHARGE SENSITIVITY

This integrated circuit can be damaged by ESD. Texas Instruments recommends that all integrated circuits be handled with appropriate precautions. Failure to observe proper handling and installation procedures can cause damage.

ESD damage can range from subtle performance degradation to complete device failure. Precision integrated circuits may be more susceptible to damage because very small parametric changes could cause the device not to meet its published specifications.

PACKAGE/ORDERING INFORMATION

PRODUCT	PACKAGE-LEAD	PACKAGE DESIGNATOR ⁽¹⁾	SPECIFIED TEMPERATURE RANGE	PACKAGE MARKING	ORDERING NUMBER	TRANSPORT MEDIA, QUANTITY
INA217	SOL-16	DW	-40°C to +125°C	INA217	INA217AIDWT	Tape and Reel, 250
"	"	"	"	"	INA217AIDWR	Tape and Reel, 1000
INA217	DIP-8	P	-40°C to +125°C	INA217	INA217AIP	Rails, 50

NOTES: (1) For the most current specifications and package information, refer to our web site at www.ti.com.

PIN CONFIGURATIONS

Top View

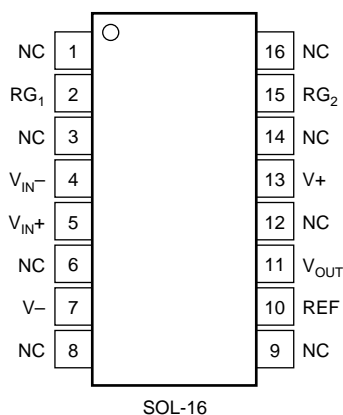

NC = No Internal Connection

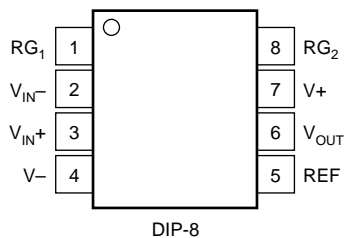

ELECTRICAL CHARACTERISTICS: $V_S = \pm 15V$

Boldface limits apply over the specified temperature range, $T_A = -40^\circ\text{C}$ to $+85^\circ\text{C}$.

$T_A = +25^\circ\text{C}$, $R_L = 2k\Omega$, $V_S = \pm 15V$, unless otherwise noted.

PARAMETER	CONDITIONS	INA217			UNITS
		MIN	TYP	MAX	
GAIN EQUATION Range Gain Error, $G = 1$ $G = 10$ $G = 100$ $G = 1000$ Gain Temp Drift Coefficient, $G = 1$ $G > 10$ Nonlinearity, $G = 1$ $G = 100$			$G = 1 + 10k/R_G$ 1 to 10000 ± 0.1 ± 0.2 ± 0.5 ± 3 ± 40 ± 0.0003 ± 0.0006	± 0.25 ± 0.7 ± 10 ± 100	V/V % % % % ppm/ $^\circ\text{C}$ ppm/ $^\circ\text{C}$ % of FS % of FS
INPUT STAGE NOISE Voltage Noise $f_O = 1\text{kHz}$ $f_O = 100\text{Hz}$ $f_O = 10\text{Hz}$ Current Noise $f_O = 1\text{kHz}$	$R_{\text{SOURCE}} = 0\Omega$		1.3 1.5 3.5 0.8		nV/ $\sqrt{\text{Hz}}$ nV/ $\sqrt{\text{Hz}}$ nV/ $\sqrt{\text{Hz}}$ pA/ $\sqrt{\text{Hz}}$
OUTPUT STAGE NOISE Voltage Noise, $f_O = 1\text{kHz}$			90		nV/ $\sqrt{\text{Hz}}$
INPUT OFFSET VOLTAGE Input Offset Voltage vs Temperature vs Power Supply	$V_{\text{CM}} = V_{\text{OUT}} = 0V$ $T_A = T_{\text{MIN}}$ to T_{MAX} $V_S = \pm 4.5V$ to $\pm 18V$		$50 + 2000/G$ $1 + 20/G$ $1 + 50/G$	$250 + 5000/G$ $3 + 200/G$	μV $\mu\text{V}/^\circ\text{C}$ $\mu\text{V}/V$
INPUT VOLTAGE RANGE Common-Mode Voltage Range Common-Mode Rejection, $G = 1$ $G = 100$	$V_{\text{IN}+} - V_{\text{IN}-} = 0V$ $V_{\text{IN}+} - V_{\text{IN}-} = 0V$ $V_{\text{CM}} = \pm 11V$, $R_{\text{SRC}} = 0\Omega$	$(V+) - 4$ $(V-) + 4$ 70 100	$(V+) - 3$ $(V-) + 3$ 80 116		V V dB dB
INPUT BIAS CURRENT Initial Bias Current vs Temperature Initial Offset Current vs Temperature			2 10 0.1 0.5	12 1	μA $\text{nA}/^\circ\text{C}$ μA $\text{nA}/^\circ\text{C}$
INPUT IMPEDANCE	Differential Common-Mode		$60 \parallel 2$ $60 \parallel 2$		$\text{M}\Omega \parallel \text{pF}$ $\text{M}\Omega \parallel \text{pF}$
DYNAMIC RESPONSE Bandwidth, Small Signal, -3dB , $G = 1$ $G = 100$ Slew Rate THD+Noise, $f = 1\text{kHz}$ Settling Time, 0.1% 0.01% Overload Recovery	$G = 100$ $G = 100$, 10V Step $G = 100$, 10V Step 50% Overdrive		3.4 800 15 0.004 2 3.5 1		MHz kHz V/ μs % μs μs μs
OUTPUT Voltage Load Capacitance Stability Short-Circuit Current	R_L to GND Continuous-to-Common	$(V+) - 2$ $(V-) + 2$	$(V+) - 1.8$ $(V-) + 1.8$ 1000 ± 60		V V pF mA
POWER SUPPLY Rated Voltage Voltage Range Current, Quiescent	$I_O = 0\text{mA}$	± 4.5	± 15 ± 10	± 18 ± 12	V V mA
TEMPERATURE RANGE Specification Operating DIP-8 SOL-16	θ_{JA}	-40 -40	 85 90	$+85$ $+125$	$^\circ\text{C}$ $^\circ\text{C}$ $^\circ\text{C}$ $^\circ\text{C}$

NOTE: (1) Gain accuracy is a function of external R_G .

TYPICAL CHARACTERISTICS

At $T_A = +25^\circ\text{C}$, $V_S = \pm 15\text{V}$, $R_L = 2\text{k}\Omega$, unless otherwise noted.

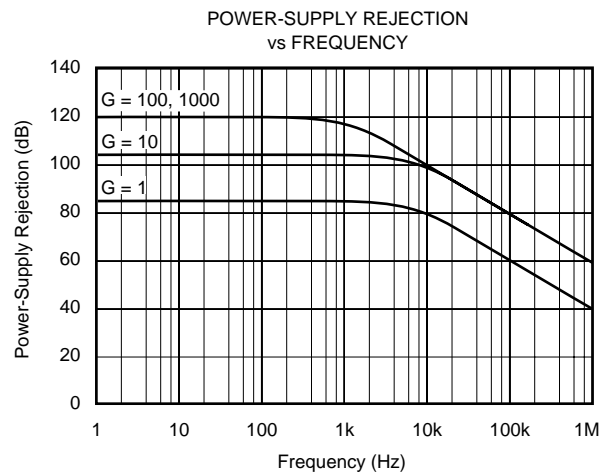
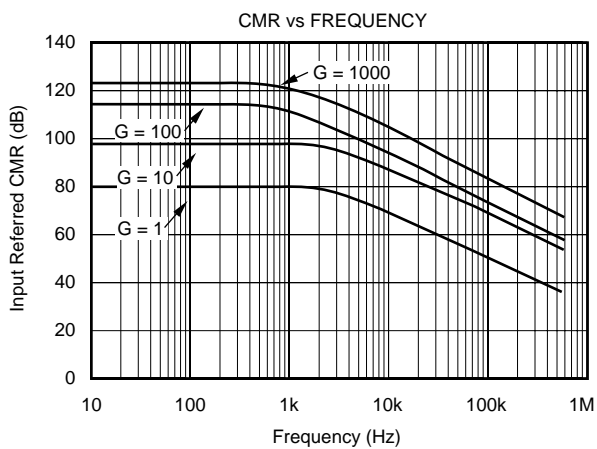
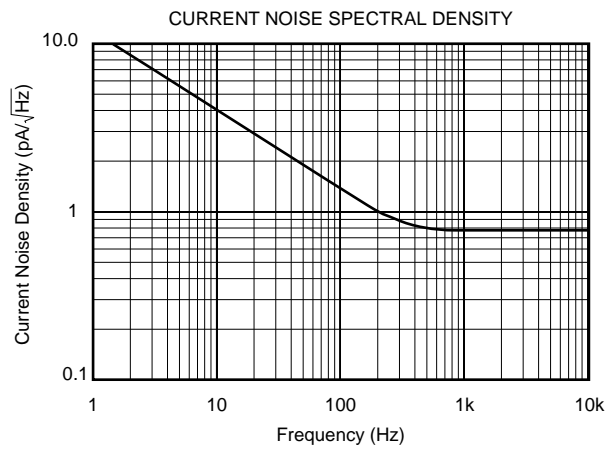
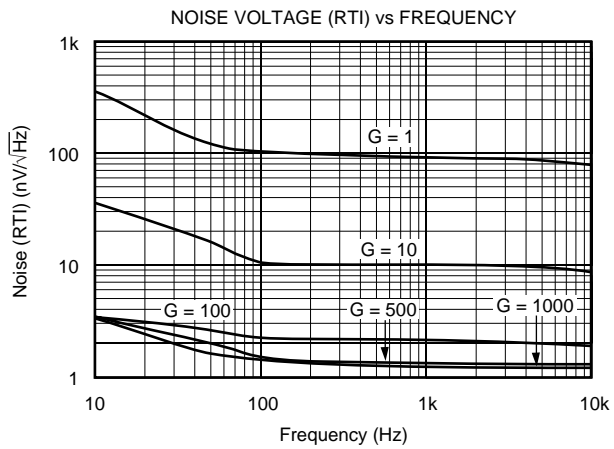
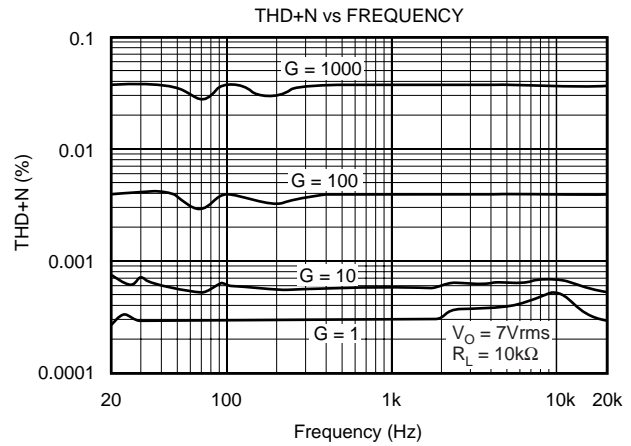
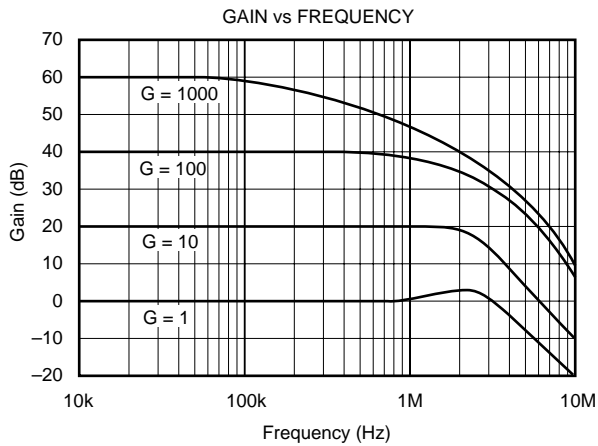

TYPICAL CHARACTERISTICS (Cont.)

At $T_A = +25^\circ\text{C}$, $V_S = \pm 15\text{V}$, $R_L = 2\text{k}\Omega$, unless otherwise noted.

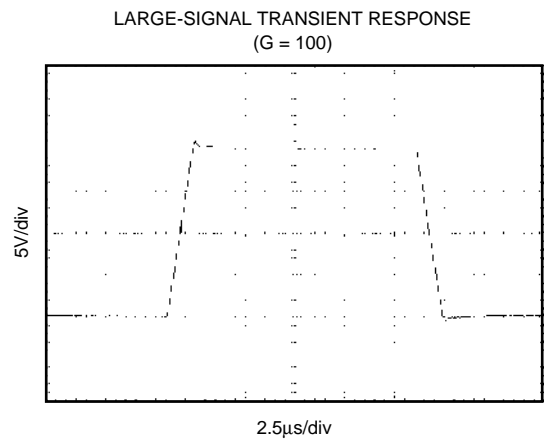
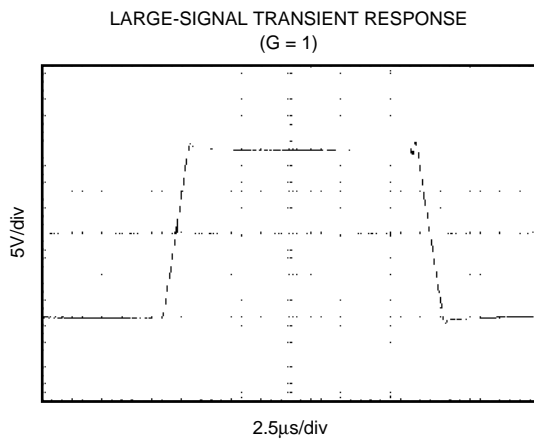
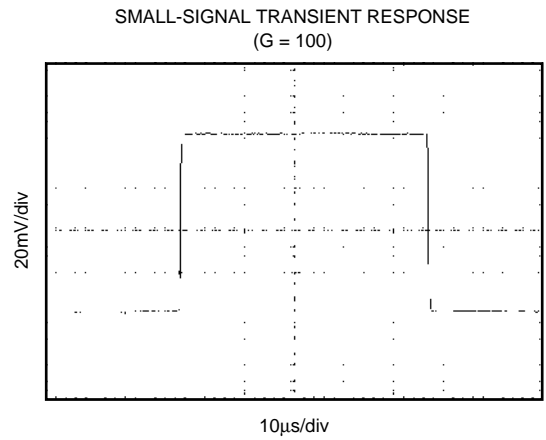
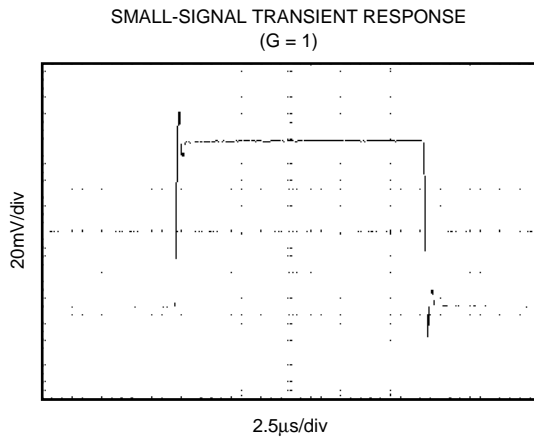
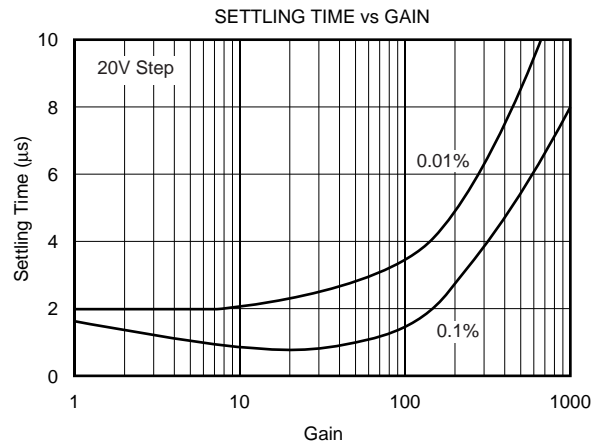
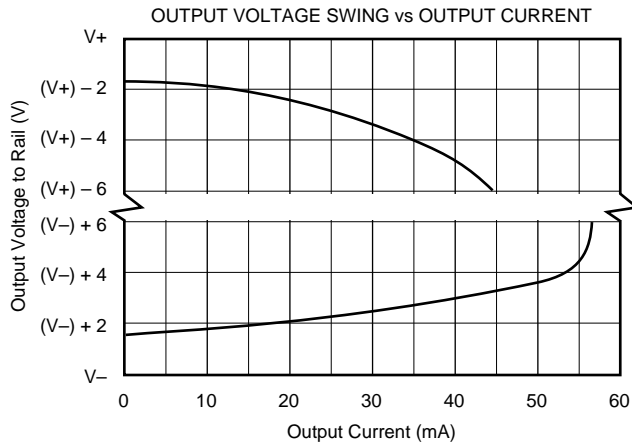

APPLICATIONS INFORMATION

Figure 1 shows the basic connections required for operation. Power supplies should be bypassed with 0.1μF tantalum capacitors near the device pins. The output Reference (pin 5) should be a low-impedance connection. Resistance of a few ohms in series with this connection will degrade the common-mode rejection of the INA217.

GAIN-SET RESISTOR

Gain is set with an external resistor, R_G, as shown in Figure 1. The two internal 5kΩ feedback resistors are laser-trimmed to 5kΩ within approximately ±0.2%. The gain equation for the INA217 is:

$$G = 1 + \frac{10,000}{R_G}$$

The temperature coefficient of the internal 5kΩ resistors is approximately ±25ppm/°C. Accuracy and TCR of the external R_G will also contribute to gain error and temperature drift. These effects can be inferred from the gain equation. Make a short, direct connection to the gain set resistor, R_G. Avoid running output signals near these sensitive input nodes.

NOISE PERFORMANCE

The INA217 provides very low-noise with low-source impedance. Its 1.3nV/√Hz voltage noise delivers near-theoretical noise performance with a source impedance of 200Ω. The input stage design used to achieve this low noise, results in

relatively high input bias current and input bias current noise. As a result, the INA217 may not provide the best noise performance with a source impedance greater than 10kΩ. For source impedance greater than 10kΩ, other instrumentation amplifiers may provide improved noise performance.

INPUT CONSIDERATIONS

Very low source impedance (less than 10Ω) can cause the INA217 to oscillate. This depends on circuit layout, signal source, and input cable characteristics. An input network consisting of a small inductor and resistor, as shown in Figure 2, can greatly reduce any tendency to oscillate. This is especially useful if a variety of input sources are to be connected to the INA217. Although not shown in other figures, this network can be used as needed with all applications shown.

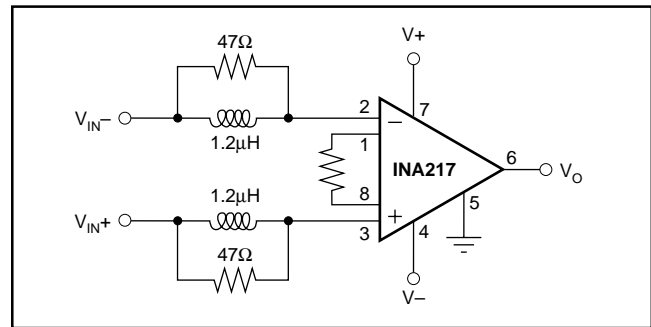

FIGURE 2. Input Stabilization Network.

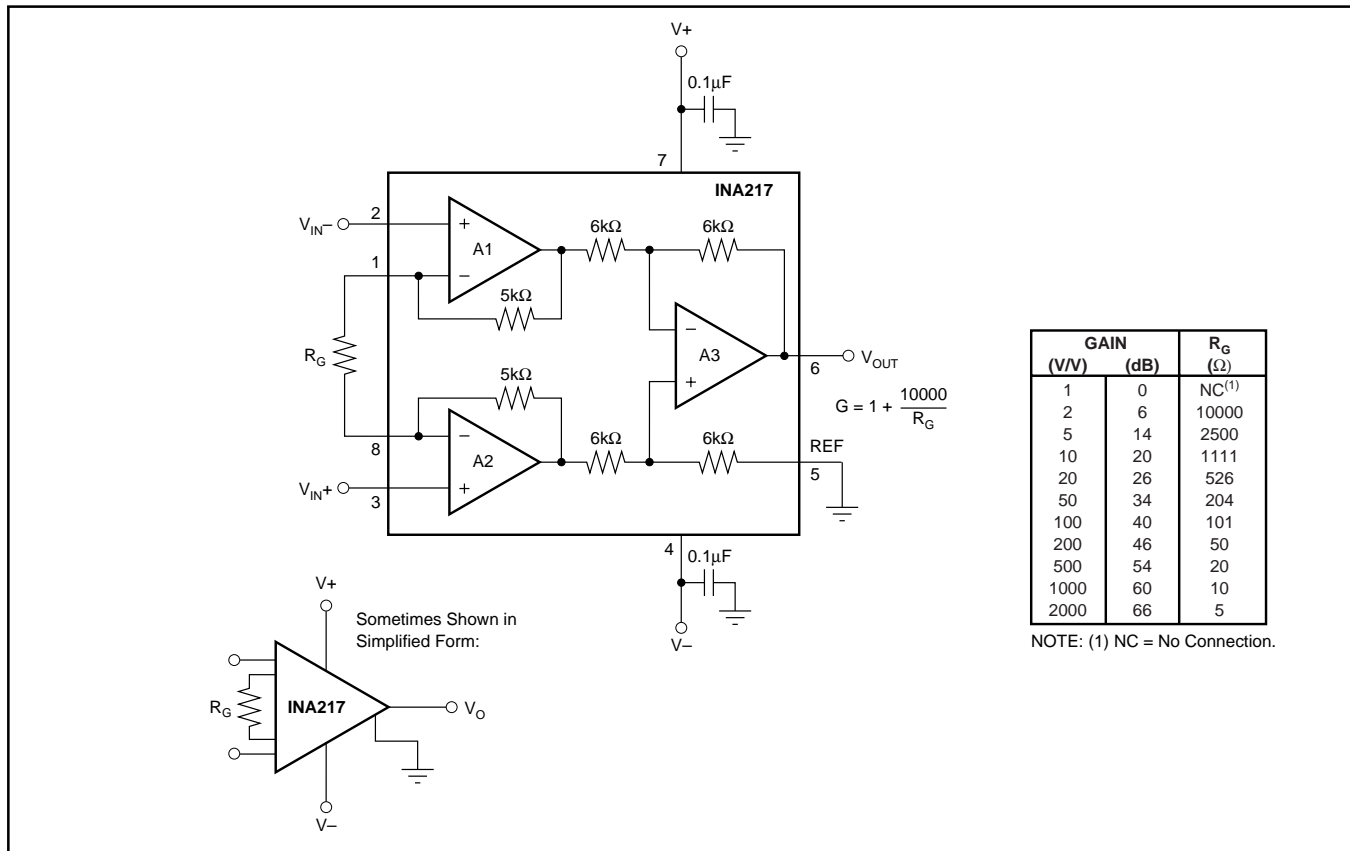

FIGURE 1. Basic Circuit Connections.

OFFSET VOLTAGE TRIM

A variable voltage applied to pin 5, as shown in Figure 3, can be used to adjust the output offset voltage. A voltage applied to pin 5 is summed with the output signal. An op amp connected as a buffer is used to provide a low impedance at pin 5 to assure good common-mode rejection.

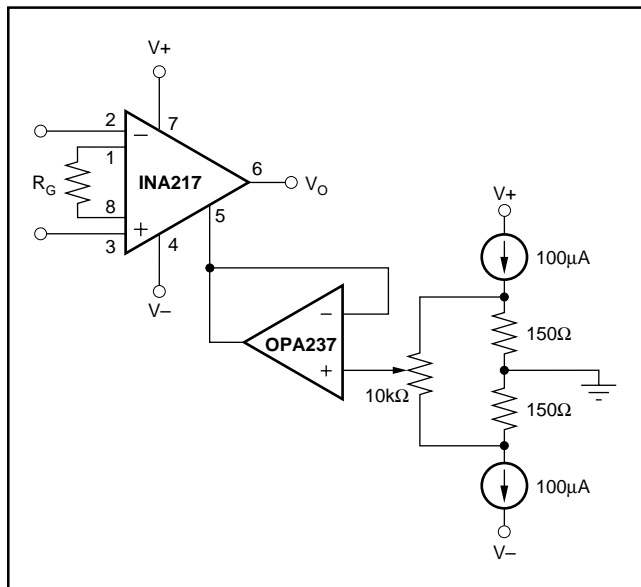

FIGURE 3. Offset Voltage Adjustment Circuit.

MICROPHONE AMPLIFIER

Figure 4 shows a typical circuit for a professional microphone input amplifier. R_1 and R_2 provide a current path for conventional 48V phantom power source for a remotely located microphone. An optional switch allows phantom power to be disabled. C_1 and C_2 block the phantom power voltage from the INA217 input circuitry. Non-polarized capacitors should be used for C_1 and C_2 if phantom power is to be disabled. For additional input protection against ESD and hot-plugging, four IN4148 diodes may be connected from the input to supply lines.

R_4 and R_5 provide a path for input bias current of the INA217. Input offset current (typically 100nA) creates a DC differential input voltage that will produce an output offset voltage. This is generally the dominant source of output offset voltage in this application. With a maximum gain of 1000 (60dB), the output offset voltage can be several volts. This may be entirely acceptable if the output is AC-coupled into the subsequent stage. An alternate technique is shown in Figure 4. An inexpensive FET-input op amp in a feedback loop drives the DC output voltage to 0V. A2 is not in the audio signal path and does not affect signal quality.

Gain is set with a variable resistor, R_7 , in series with R_6 . R_6 determines the maximum gain. The total resistance, $R_6 + R_7$, determines the lowest gain. A special reverse-log taper potentiometer for R_7 can be used to create a linear change (in dB) with rotation.

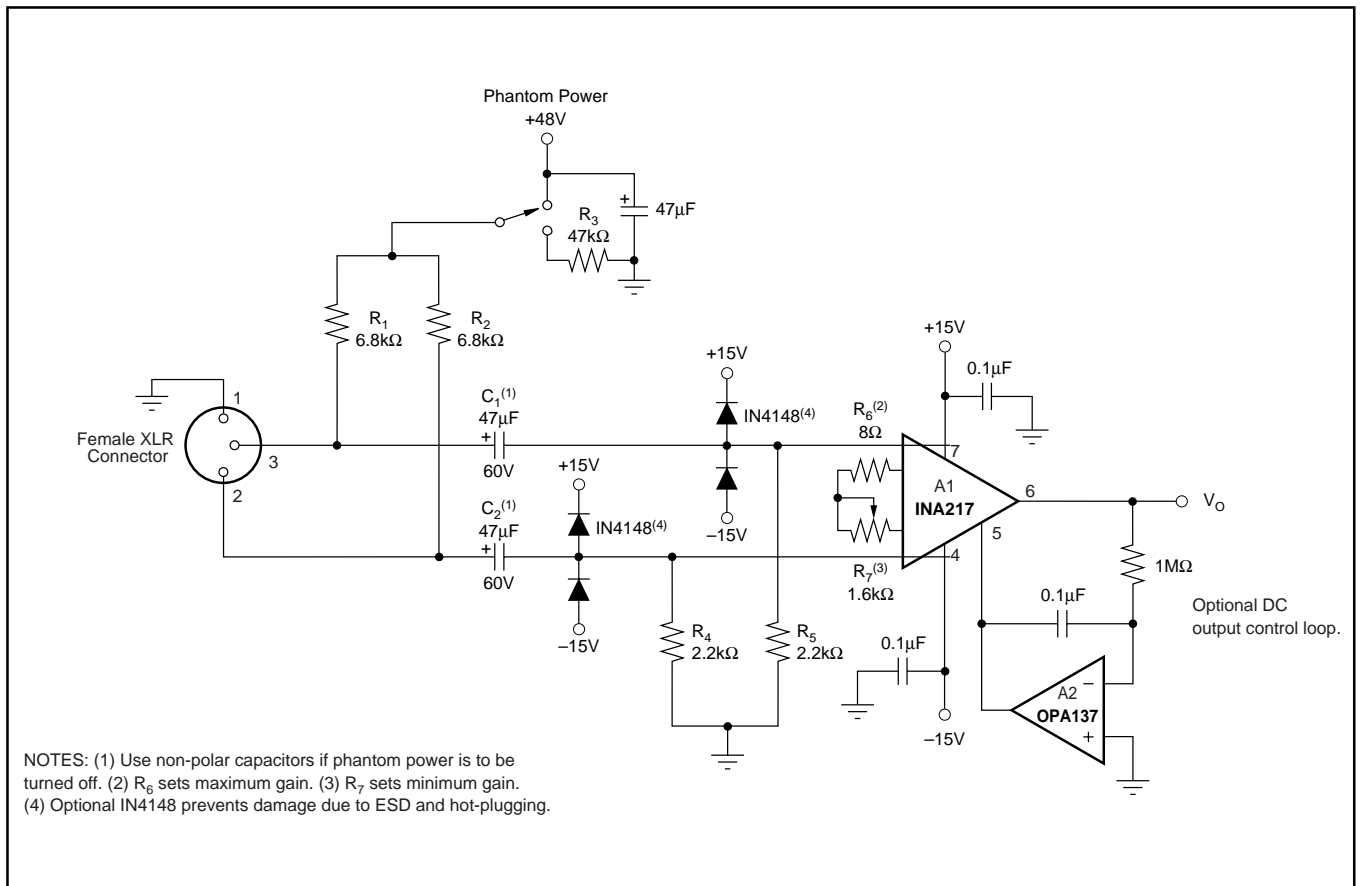
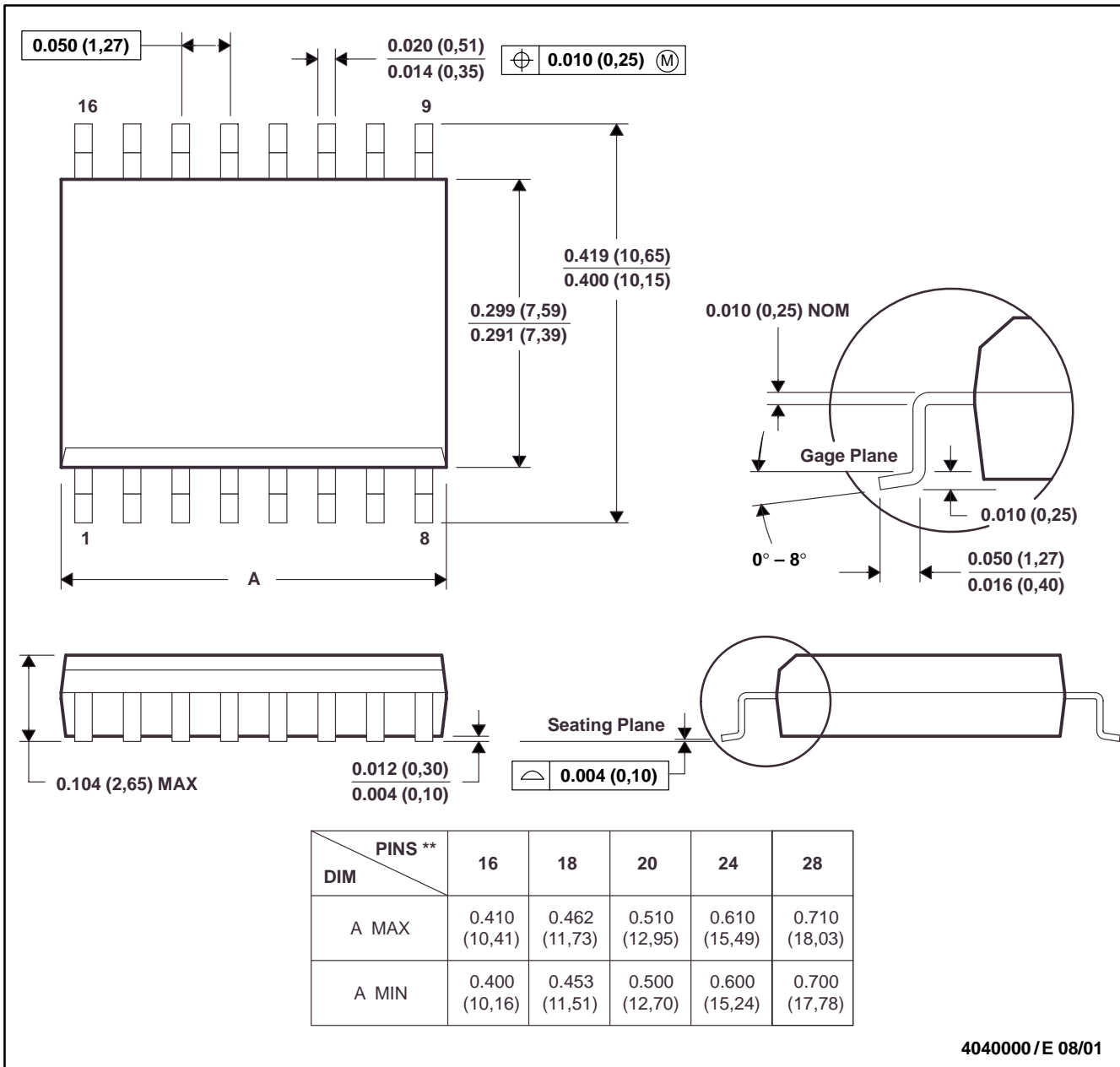
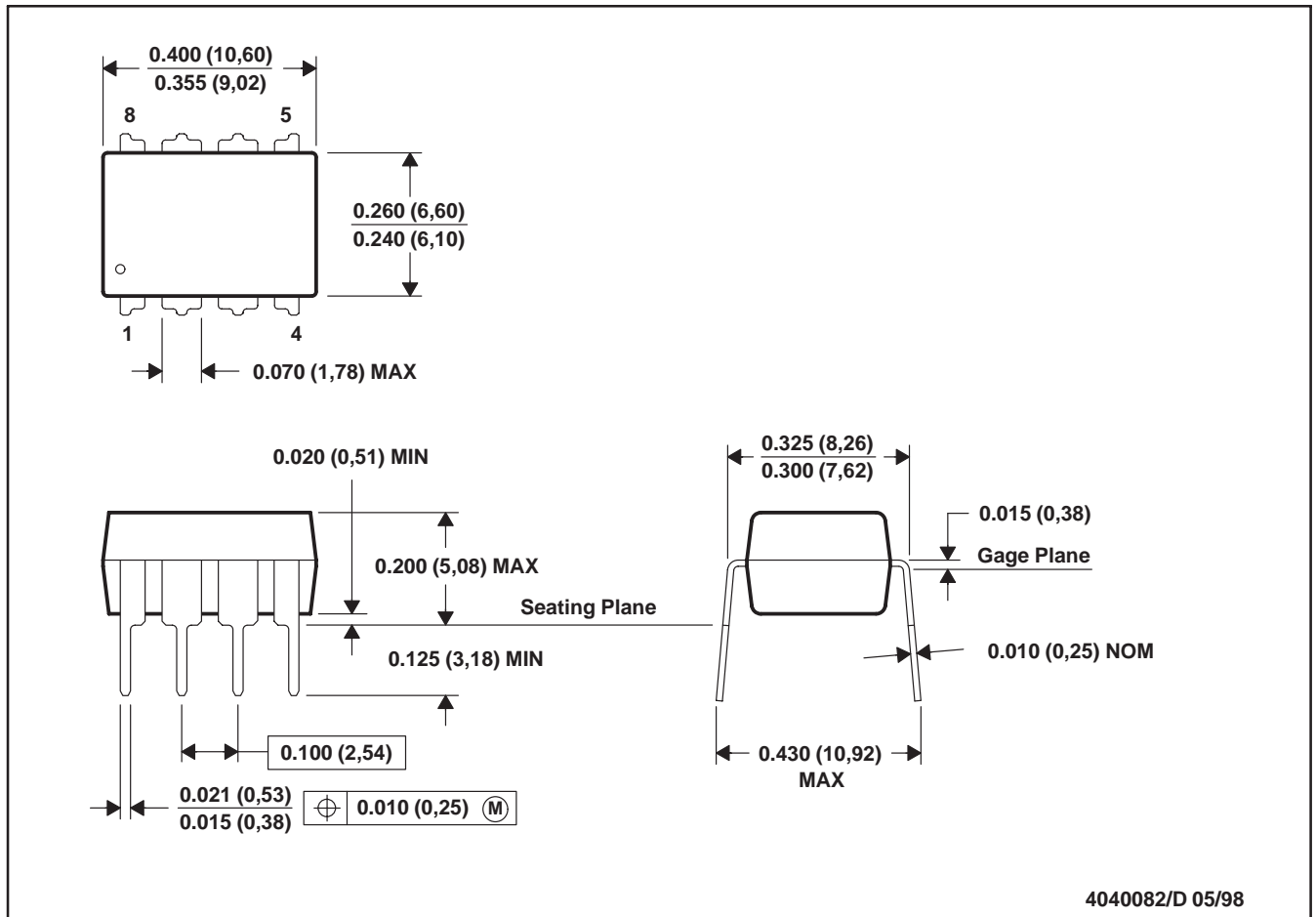

FIGURE 4. Phantom-Powered Microphone Preamplifier.

16 PINS SHOWN



- NOTES: A. All linear dimensions are in inches (millimeters).
 B. This drawing is subject to change without notice.
 C. Body dimensions do not include mold flash or protrusion not to exceed 0.006 (0,15).
 D. Falls within JEDEC MS-013



- NOTES: A. All linear dimensions are in inches (millimeters).
 B. This drawing is subject to change without notice.
 C. Falls within JEDEC MS-001

IMPORTANT NOTICE

Texas Instruments Incorporated and its subsidiaries (TI) reserve the right to make corrections, modifications, enhancements, improvements, and other changes to its products and services at any time and to discontinue any product or service without notice. Customers should obtain the latest relevant information before placing orders and should verify that such information is current and complete. All products are sold subject to TI's terms and conditions of sale supplied at the time of order acknowledgment.

TI warrants performance of its hardware products to the specifications applicable at the time of sale in accordance with TI's standard warranty. Testing and other quality control techniques are used to the extent TI deems necessary to support this warranty. Except where mandated by government requirements, testing of all parameters of each product is not necessarily performed.

TI assumes no liability for applications assistance or customer product design. Customers are responsible for their products and applications using TI components. To minimize the risks associated with customer products and applications, customers should provide adequate design and operating safeguards.

TI does not warrant or represent that any license, either express or implied, is granted under any TI patent right, copyright, mask work right, or other TI intellectual property right relating to any combination, machine, or process in which TI products or services are used. Information published by TI regarding third-party products or services does not constitute a license from TI to use such products or services or a warranty or endorsement thereof. Use of such information may require a license from a third party under the patents or other intellectual property of the third party, or a license from TI under the patents or other intellectual property of TI.

Reproduction of information in TI data books or data sheets is permissible only if reproduction is without alteration and is accompanied by all associated warranties, conditions, limitations, and notices. Reproduction of this information with alteration is an unfair and deceptive business practice. TI is not responsible or liable for such altered documentation.

Resale of TI products or services with statements different from or beyond the parameters stated by TI for that product or service voids all express and any implied warranties for the associated TI product or service and is an unfair and deceptive business practice. TI is not responsible or liable for any such statements.

Mailing Address:

Texas Instruments
Post Office Box 655303
Dallas, Texas 75265