

## LM1085 3A Low Dropout Positive Regulators

 Check for Samples: [LM1085](#)

### FEATURES

- Available in 3.3V, 5.0V, 12V and Adjustable Versions
- Current Limiting and Thermal Protection
- Output Current 3A
- Line Regulation 0.015% (typical)
- Load Regulation 0.1% (typical)

### APPLICATIONS

- High Efficiency Linear Regulators
- Battery Charger
- Post Regulation for Switching Supplies
- Constant Current Regulator
- Microprocessor Supply

### Connection Diagram

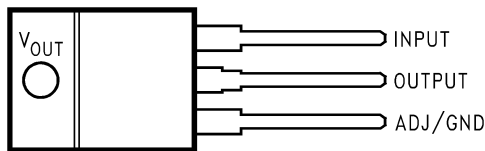

Figure 1. TO-220 Top View

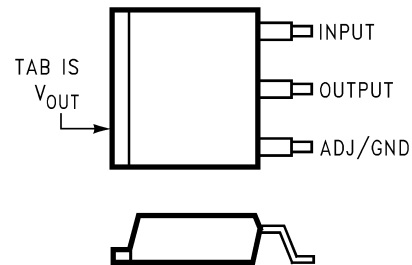

Figure 2. DDPAK/TO-263 Top View

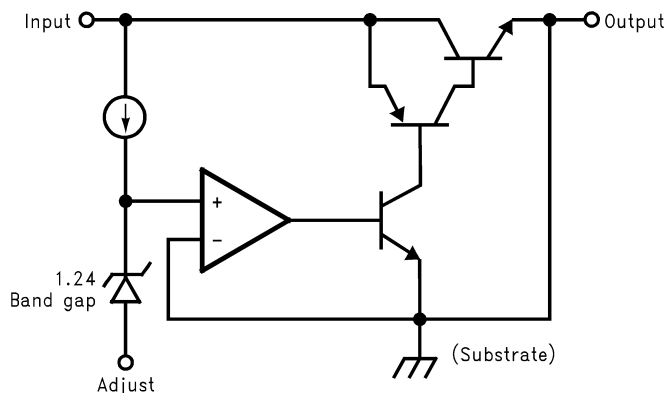
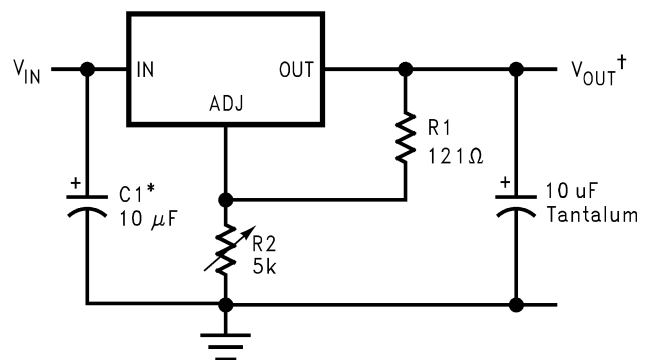

Figure 3. Basic Functional Diagram, Adjustable Version



\*NEEDED IF DEVICE IS FAR FROM FILTER CAPACITORS

$$V_{OUT}^{\dagger} = 1.25V \left(1 + \frac{R2}{R1}\right)$$

 Figure 4. Application Circuit  
1.2V to 15V Adjustable Regulator

Please be aware that an important notice concerning availability, standard warranty, and use in critical applications of Texas Instruments semiconductor products and disclaimers thereto appears at the end of this data sheet.

All trademarks are the property of their respective owners.

Simplified Schematic

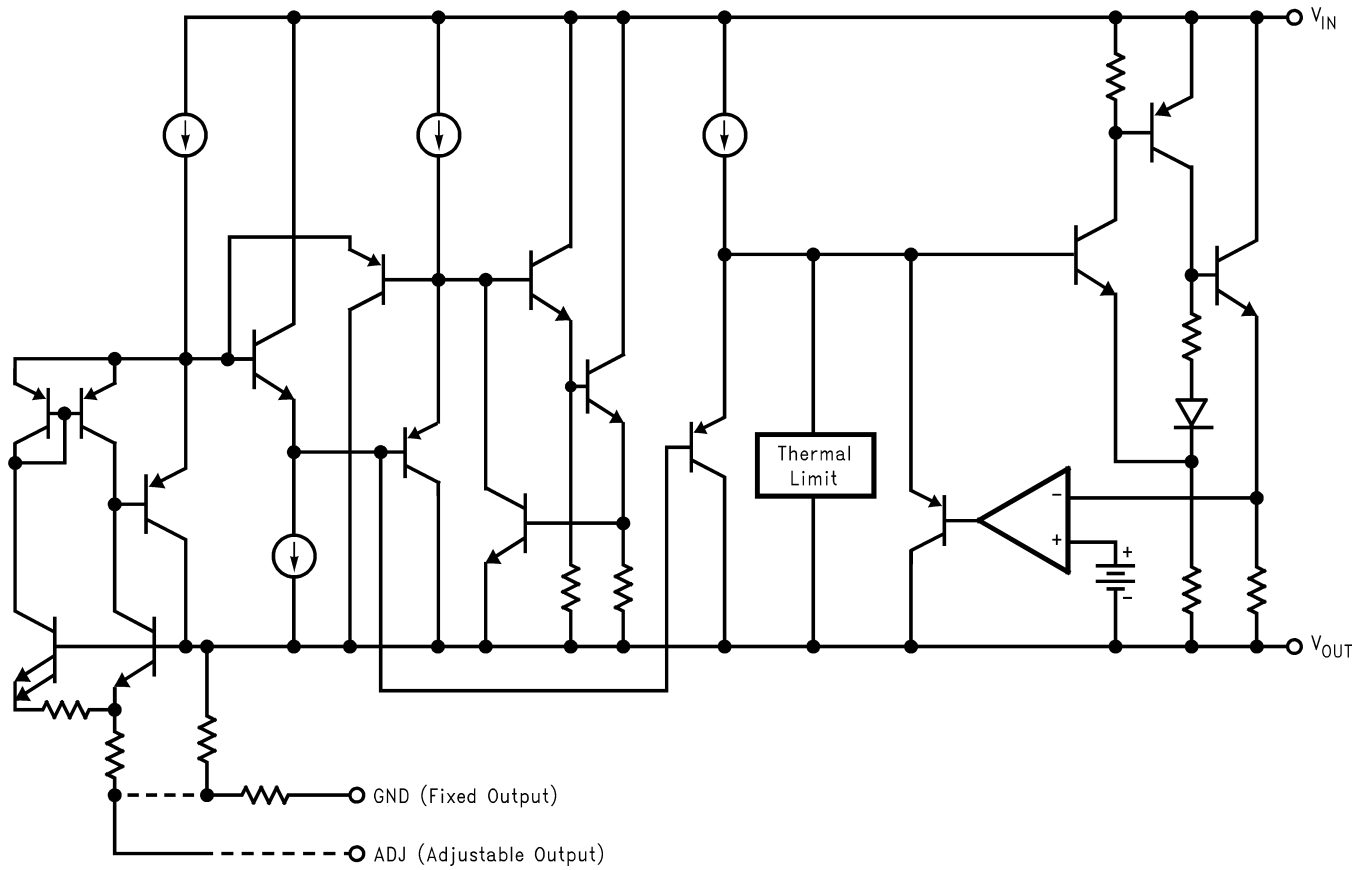

Figure 5.



These devices have limited built-in ESD protection. The leads should be shorted together or the device placed in conductive foam during storage or handling to prevent electrostatic damage to the MOS gates.

### Absolute Maximum Ratings<sup>(1)(2)</sup>

Maximum Input to Output Voltage Differential	
LM1085-ADJ	29V
LM1085-12	18V
LM1085-3.3	27V
LM1085-5.0	25V
Power Dissipation <sup>(3)</sup>	Internally Limited
Junction Temperature (T <sub>J</sub> ) <sup>(4)</sup>	150°C
Storage Temperature Range	-65°C to 150°C
Lead Temperature	260°C, to 10 sec
ESD Tolerance <sup>(5)</sup>	2000V

- (1) Absolute Maximum Ratings indicate limits beyond which damage to the device may occur. Operating Ratings indicate conditions for which the device is intended to be functional, but specific performance is not ensured. For ensured specifications and the test conditions, see the Electrical Characteristics.
- (2) If Military/Aerospace specified devices are required, please contact the Texas Instruments Sales Office/ Distributors for availability and specifications.
- (3) Power dissipation is kept in a safe range by current limiting circuitry. Refer to Overload Recovery in Application Notes.
- (4) The maximum power dissipation is a function of T<sub>J(max)</sub>, θ<sub>JA</sub>, and T<sub>A</sub>. The maximum allowable power dissipation at any ambient temperature is P<sub>D</sub> = (T<sub>J(max)</sub> - T<sub>A</sub>) / θ<sub>JA</sub>. All numbers apply for packages soldered directly into a PC board. Refer to Thermal Considerations in the Application Notes.
- (5) For testing purposes, ESD was applied using human body model, 1.5kΩ in series with 100pF.

### Operating Ratings<sup>(1)</sup>

Junction Temperature (T <sub>J</sub> ) <sup>(2)</sup>	-40°C to 125°C
---	----------------

- (1) Absolute Maximum Ratings indicate limits beyond which damage to the device may occur. Operating Ratings indicate conditions for which the device is intended to be functional, but specific performance is not ensured. For ensured specifications and the test conditions, see the Electrical Characteristics.
- (2) The maximum power dissipation is a function of T<sub>J(max)</sub>, θ<sub>JA</sub>, and T<sub>A</sub>. The maximum allowable power dissipation at any ambient temperature is P<sub>D</sub> = (T<sub>J(max)</sub> - T<sub>A</sub>) / θ<sub>JA</sub>. All numbers apply for packages soldered directly into a PC board. Refer to Thermal Considerations in the Application Notes.

### Electrical Characteristics

Limits in standard type are for T<sub>J</sub> = 25°C only; limits in **boldface type** apply over the operating junction temperature (T<sub>J</sub>) range of **-40°C to +125°C**. Minimum and Maximum limits are ensured through test, design, or statistical correlation. Typical values represent the most likely parametric norm at T<sub>J</sub> = 25°C, and are provided for reference purposes only.

Symbol	Parameter	Conditions	Min (1)	Typ (2)	Max (1)	Units
V <sub>REF</sub>	Reference Voltage <sup>(3)</sup>	LM1085-ADJ I <sub>OUT</sub> = 10mA, V <sub>IN</sub> - V <sub>OUT</sub> = 3V 10mA ≤ I <sub>OUT</sub> ≤ I <sub>FULL LOAD</sub> , 1.5V ≤ (V <sub>IN</sub> - V <sub>OUT</sub> ) ≤ 15V	1.238 <b>1.225</b>	1.250 <b>1.250</b>	1.262 <b>1.270</b>	V
V <sub>OUT</sub>	Output Voltage <sup>(3)</sup>	LM1085-3.3 I <sub>OUT</sub> = 0mA, V <sub>IN</sub> = 5V 0 ≤ I <sub>OUT</sub> ≤ I <sub>FULL LOAD</sub> , 4.8V ≤ V <sub>IN</sub> ≤ 15V	3.270 <b>3.235</b>	3.300 <b>3.300</b>	3.330 <b>3.365</b>	V
		LM1085-5.0 I <sub>OUT</sub> = 0mA, V <sub>IN</sub> = 8V 0 ≤ I <sub>OUT</sub> ≤ I <sub>FULL LOAD</sub> , 6.5V ≤ V <sub>IN</sub> ≤ 20V	4.950 <b>4.900</b>	5.000 <b>5.000</b>	5.050 <b>5.100</b>	V
		LM1085-12 I <sub>OUT</sub> = 0mA, V <sub>IN</sub> = 15V 0 ≤ I <sub>OUT</sub> ≤ I <sub>FULL LOAD</sub> , 13.5V ≤ V <sub>IN</sub> ≤ 25V	11.880 <b>11.760</b>	12.000 <b>12.000</b>	12.120 <b>12.240</b>	V

- (1) All limits are specified by testing or statistical analysis.
- (2) Typical Values represent the most likely parametric norm.
- (3) I<sub>FULL LOAD</sub> is defined in the current limit curves. The I<sub>FULL LOAD</sub> Curve defines the current limit as a function of input-to-output voltage. Note that 30W power dissipation for the LM1085 is only achievable over a limited range of input-to-output voltage.

## Electrical Characteristics (continued)

Limits in standard type are for  $T_J = 25^\circ\text{C}$  only; limits in **boldface type** apply over the operating junction temperature ( $T_J$ ) range of  $-40^\circ\text{C}$  to  $+125^\circ\text{C}$ . Minimum and Maximum limits are ensured through test, design, or statistical correlation. Typical values represent the most likely parametric norm at  $T_J = 25^\circ\text{C}$ , and are provided for reference purposes only.

Symbol	Parameter	Conditions	Min (1)	Typ (2)	Max (1)	Units
$\Delta V_{\text{OUT}}$	Line Regulation (4)	LM1085-ADJ, $I_{\text{OUT}} = 10\text{mA}$ , $1.5\text{V} \leq (V_{\text{IN}} - V_{\text{OUT}}) \leq 15\text{V}$		0.015 <b>0.035</b>	0.2 <b>0.2</b>	%
		LM1085-3.3, $I_{\text{OUT}} = 0\text{mA}$ , $4.8\text{V} \leq V_{\text{IN}} \leq 15\text{V}$		0.5 <b>1.0</b>	6 <b>6</b>	mV
		LM1085-5.0, $I_{\text{OUT}} = 0\text{mA}$ , $6.5\text{V} \leq V_{\text{IN}} \leq 20\text{V}$		0.5 <b>1.0</b>	10 <b>10</b>	mV
		LM1085-12, $I_{\text{OUT}} = 0\text{mA}$ , $13.5\text{V} \leq V_{\text{IN}} \leq 25\text{V}$		1.0 <b>2.0</b>	25 <b>25</b>	mV
$\Delta V_{\text{OUT}}$	Load Regulation (4)	LM1085-ADJ, $(V_{\text{IN}} - V_{\text{OUT}}) = 3\text{V}$ , $10\text{mA} \leq I_{\text{OUT}} \leq I_{\text{FULL LOAD}}$		0.1 <b>0.2</b>	0.3 <b>0.4</b>	%
		LM1085-3.3, $V_{\text{IN}} = 5\text{V}$ , $0 \leq I_{\text{OUT}} \leq I_{\text{FULL LOAD}}$		3 <b>7</b>	15 <b>20</b>	mV
		LM1085-5.0, $V_{\text{IN}} = 8\text{V}$ , $0 \leq I_{\text{OUT}} \leq I_{\text{FULL LOAD}}$		5 <b>10</b>	20 <b>35</b>	mV
		LM1085-12, $V_{\text{IN}} = 15\text{V}$ , $0 \leq I_{\text{OUT}} \leq I_{\text{FULL LOAD}}$		12 <b>24</b>	36 <b>72</b>	mV
$V_{\text{DO}}$	Dropout Voltage (5)	LM1085-ADJ, 3.3, 5, 12 $\Delta V_{\text{REF}}$ , $\Delta V_{\text{OUT}} = 1\%$ , $I_{\text{OUT}} = 3\text{A}$		<b>1.3</b>	<b>1.5</b>	V
$I_{\text{LIMIT}}$	Current Limit	LM1085-ADJ, $V_{\text{IN}} - V_{\text{OUT}} = 5\text{V}$	<b>3.2</b>	<b>5.5</b>		A
		LM1085-ADJ, $V_{\text{IN}} - V_{\text{OUT}} = 25\text{V}$	<b>0.2</b>	<b>0.5</b>		A
		LM1085-3.3, $V_{\text{IN}} = 8.0\text{V}$	<b>3.2</b>	<b>5.5</b>		A
		LM1085-5.0, $V_{\text{IN}} = 10\text{V}$	<b>3.2</b>	<b>5.5</b>		A
		LM1085-12, $V_{\text{IN}} = 17\text{V}$	<b>3.2</b>	<b>5.5</b>		A
	Minimum Load Current (6)	LM1085-ADJ, $V_{\text{IN}} - V_{\text{OUT}} = 25\text{V}$		<b>5.0</b>	<b>10.0</b>	mA
$I_{\text{GND}}$	Quiescent Current	LM1085-3.3, $V_{\text{IN}} \leq 18\text{V}$		<b>5.0</b>	<b>10.0</b>	mA
		LM1085-5.0, $V_{\text{IN}} \leq 20\text{V}$		<b>5.0</b>	<b>10.0</b>	mA
		LM1085-12, $V_{\text{IN}} \leq 25\text{V}$		<b>5.0</b>	<b>10.0</b>	mA
	Thermal Regulation	$T_A = 25^\circ\text{C}$ , 30ms Pulse		.004	0.02	%/W
	Ripple Rejection	$f_{\text{RIPPLE}} = 120\text{Hz}$ , $C_{\text{OUT}} = 25\mu\text{F}$ Tantalum, $I_{\text{OUT}} = 3\text{A}$				
		LM1085-ADJ $C_{\text{ADJ}} = 25\mu\text{F}$ , $(V_{\text{IN}} - V_{\text{O}}) = 3\text{V}$	<b>60</b>	<b>75</b>		dB
		LM1085-3.3, $V_{\text{IN}} = 6.3\text{V}$	<b>60</b>	<b>72</b>		dB
		LM1085-5.0, $V_{\text{IN}} = 8.0\text{V}$	<b>60</b>	<b>68</b>		dB
		LM1085-12, $V_{\text{IN}} = 15\text{V}$	<b>54</b>	<b>60</b>		dB
$I_{\text{ADJ}}$	Adjust Pin Current	LM1085-ADJ		55	<b>120</b>	$\mu\text{A}$
$\Delta I_{\text{ADJ}}$	Adjust Pin Current Change	LM1085-ADJ $10\text{mA} \leq I_{\text{OUT}} \leq I_{\text{FULL LOAD}}$ , $1.5\text{V} \leq V_{\text{IN}} - V_{\text{OUT}} \leq 25\text{V}$		<b>0.2</b>	<b>5</b>	$\mu\text{A}$
	Temperature Stability			<b>0.5</b>		%
	Long Term Stability	$T_A = 125^\circ\text{C}$ , 1000 Hrs		0.3	1.0	%
	RMS Output Noise (% of $V_{\text{OUT}}$ )	$10\text{Hz} \leq f \leq 10\text{kHz}$		0.003		%
$\theta_{\text{JC}}$	Thermal Resistance (Junction-to-Case)	3-Lead DDPACK/TO-263	-	0.7	-	$^\circ\text{C/W}$
		3-Lead TO-220	-	0.7	-	$^\circ\text{C/W}$

(4) Load and line regulation are measured at constant junction temperature, and are ensured up to the maximum power dissipation of 30W. Power dissipation is determined by the input/output differential and the output current. Ensured maximum power dissipation will not be available over the full input/output range.

(5) Dropout voltage is specified over the full output current range of the device.

(6) The minimum output current required to maintain regulation.

### Typical Performance Characteristics

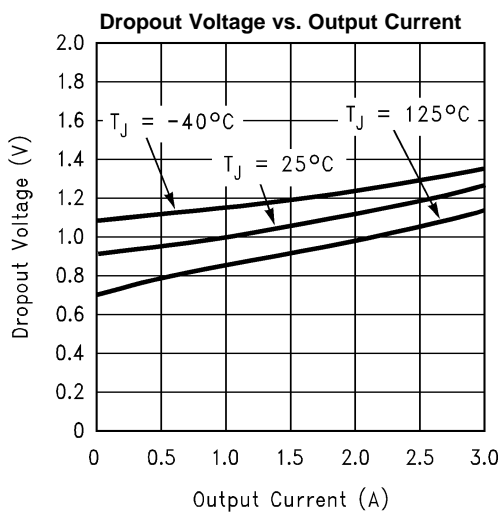

Figure 6.

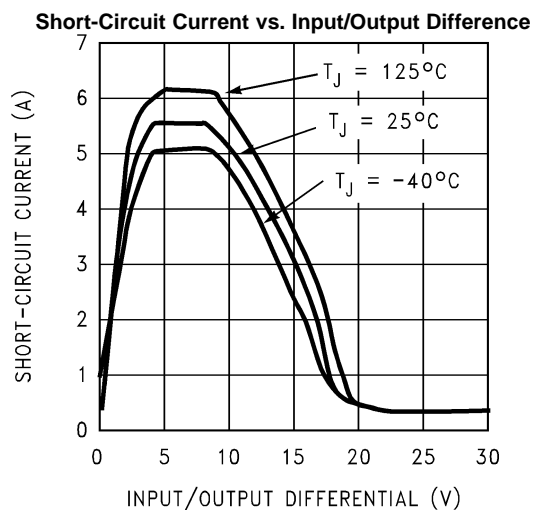

Figure 7.

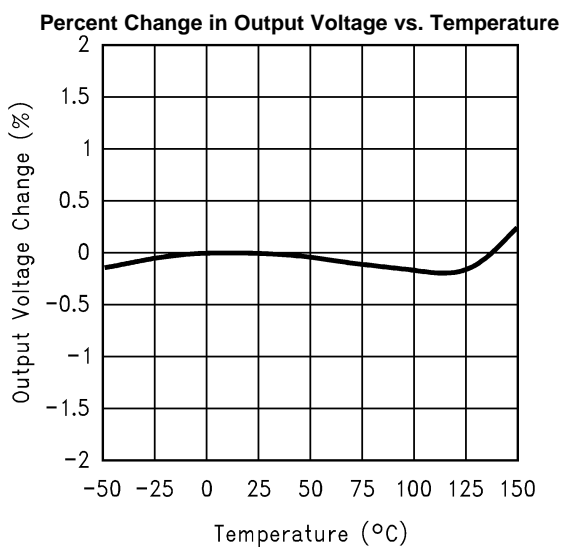

Figure 8.

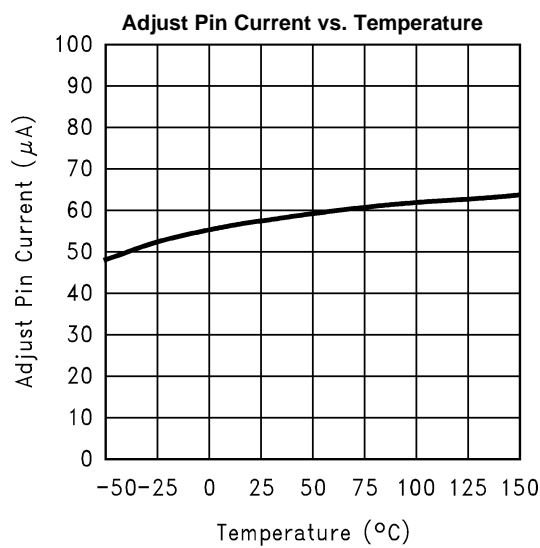

Figure 9.

**Typical Performance Characteristics (continued)**

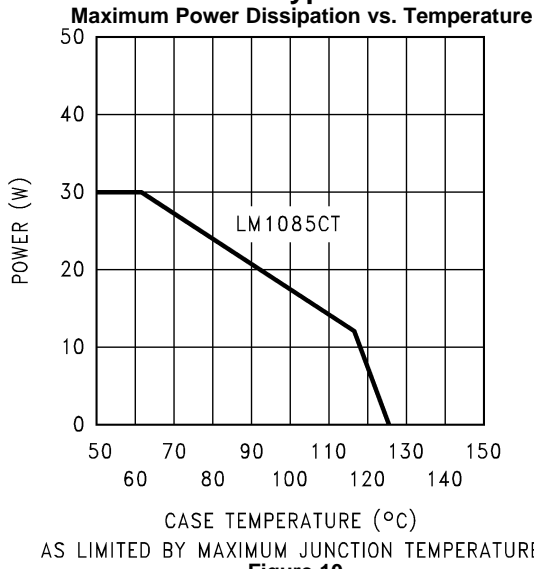

Figure 10.

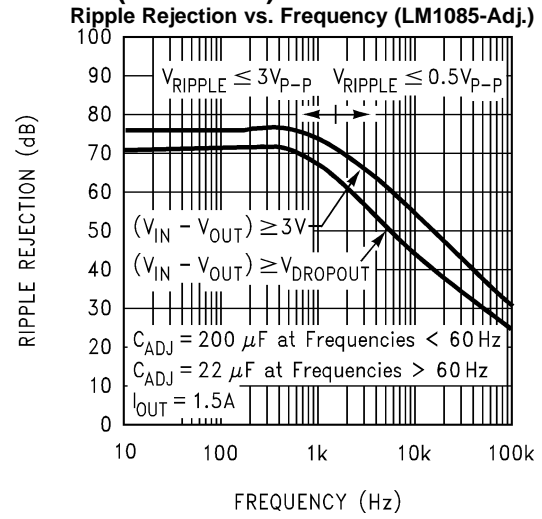

Figure 11.

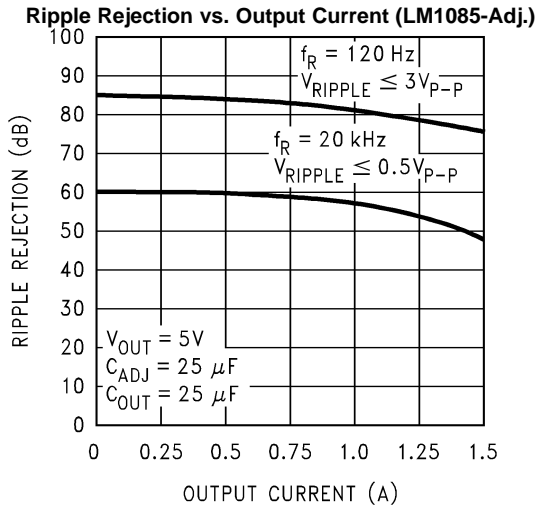

Figure 12.

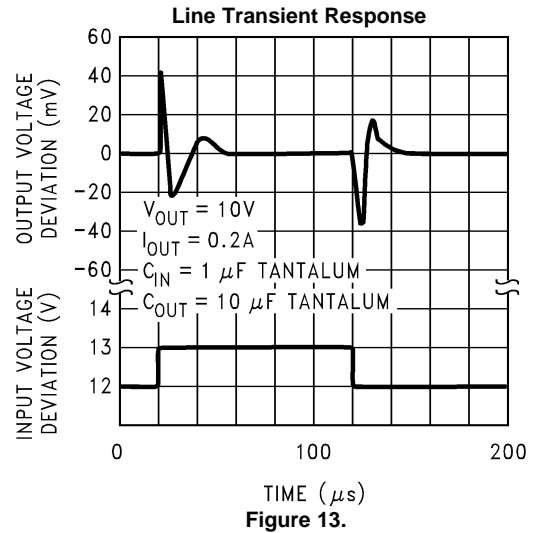

Figure 13.

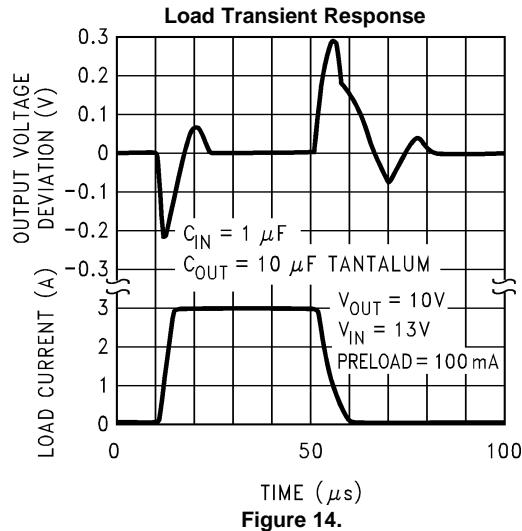

Figure 14.

## APPLICATION NOTE

### GENERAL

Figure 15 shows a basic functional diagram for the LM1085-Adj (excluding protection circuitry). The topology is basically that of the LM317 except for the pass transistor. Instead of a Darlington NPN with its two diode voltage drop, the LM1085 uses a single NPN. This results in a lower dropout voltage. The structure of the pass transistor is also known as a quasi LDO. The advantage a quasi LDO over a PNP LDO is its inherently lower quiescent current. The LM1085 is ensured to provide a minimum dropout voltage 1.5V over temperature, at full load.

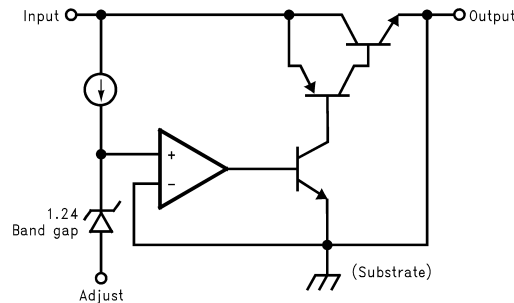

Figure 15. Basic Functional Diagram for the LM1085, excluding Protection circuitry

### OUTPUT VOLTAGE

The LM1085 adjustable version develops at 1.25V reference voltage, ( $V_{REF}$ ), between the output and the adjust terminal. As shown in figure 2, this voltage is applied across resistor R1 to generate a constant current I1. This constant current then flows through R2. The resulting voltage drop across R2 adds to the reference voltage to sets the desired output voltage.

The current  $I_{ADJ}$  from the adjustment terminal introduces an output error. But since it is small (120uA max), it becomes negligible when R1 is in the 100Ω range.

For fixed voltage devices, R1 and R2 are integrated inside the devices.

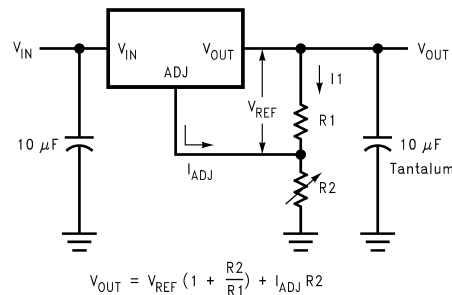

Figure 16. Basic Adjustable Regulator

### STABILITY CONSIDERATION

Stability consideration primarily concern the phase response of the feedback loop. In order for stable operation, the loop must maintain negative feedback. The LM1085 requires a certain amount series resistance with capacitive loads. This series resistance introduces a zero within the loop to increase phase margin and thus increase stability. The equivalent series resistance (ESR) of solid tantalum or aluminum electrolytic capacitors is used to provide the appropriate zero (approximately 500 kHz).

The Aluminum electrolytic are less expensive than tantalums, but their ESR varies exponentially at cold temperatures; therefore requiring close examination when choosing the desired transient response over temperature. Tantalums are a convenient choice because their ESR varies less than 2:1 over temperature.

The recommended load/decoupling capacitance is a 10uF tantalum or a 50uF aluminum. These values will assure stability for the majority of applications.

The adjustable versions allows an additional capacitor to be used at the ADJ pin to increase ripple rejection. If this is done the output capacitor should be increased to 22uF for tantalums or to 150uF for aluminum.

Capacitors other than tantalum or aluminum can be used at the adjust pin and the input pin. A 10uF capacitor is a reasonable value at the input. See [RIPPLE REJECTION](#) section regarding the value for the adjust pin capacitor.

It is desirable to have large output capacitance for applications that entail large changes in load current (microprocessors for example). The higher the capacitance, the larger the available charge per demand. It is also desirable to provide low ESR to reduce the change in output voltage:

$$V = \Delta I \times \text{ESR}$$

It is common practice to use several tantalum and ceramic capacitors in parallel to reduce this change in the output voltage by reducing the overall ESR.

Output capacitance can be increased indefinitely to improve transient response and stability.

## RIPPLE REJECTION

Ripple rejection is a function of the open loop gain within the feed-back loop (refer to [Figure 15](#) and [Figure 16](#)). The LM1085 exhibits 75dB of ripple rejection (typ.). When adjusted for voltages higher than  $V_{REF}$ , the ripple rejection decreases as function of adjustment gain:  $(1+R1/R2)$  or  $V_O/V_{REF}$ . Therefore a 5V adjustment decreases ripple rejection by a factor of four (-12dB); Output ripple increases as adjustment voltage increases.

However, the adjustable version allows this degradation of ripple rejection to be compensated. The adjust terminal can be bypassed to ground with a capacitor ( $C_{ADJ}$ ). The impedance of the  $C_{ADJ}$  should be equal to or less than  $R1$  at the desired ripple frequency. This bypass capacitor prevents ripple from being amplified as the output voltage is increased.

$$1/(2\pi * f_{RIPPLE} * C_{ADJ}) \leq R_1$$

## LOAD REGULATION

The LM1085 regulates the voltage that appears between its output and ground pins, or between its output and adjust pins. In some cases, line resistances can introduce errors to the voltage across the load. To obtain the best load regulation, a few precautions are needed.

[Figure 17](#) shows a typical application using a fixed output regulator.  $R_{t1}$  and  $R_{t2}$  are the line resistances.  $V_{LOAD}$  is less than the  $V_{OUT}$  by the sum of the voltage drops along the line resistances. In this case, the load regulation seen at the  $R_{LOAD}$  would be degraded from the data sheet specification. To improve this, the load should be tied directly to the output terminal on the positive side and directly tied to the ground terminal on the negative side.

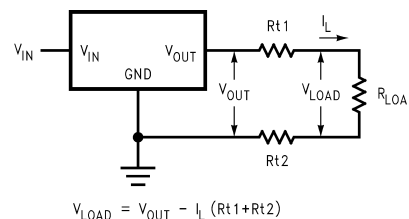

**Figure 17. Typical Application using Fixed Output Regulator**

When the adjustable regulator is used ([Figure 18](#)), the best performance is obtained with the positive side of the resistor  $R1$  tied directly to the output terminal of the regulator rather than near the load. This eliminates line drops from appearing effectively in series with the reference and degrading regulation. For example, a 5V regulator with  $0.05\Omega$  resistance between the regulator and load will have a load regulation due to line resistance of  $0.05\Omega \times I_L$ . If  $R1$  ( $= 125\Omega$ ) is connected near the load the effective line resistance will be  $0.05\Omega (1 + R2/R1)$  or in this case, it is 4 times worse. In addition, the ground side of the resistor  $R2$  can be returned near the ground of the load to provide remote ground sensing and improve load regulation.

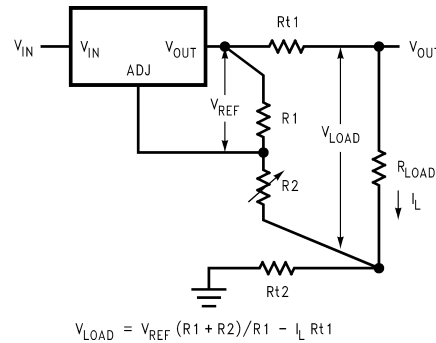

Figure 18. Best Load Regulation using Adjustable Output Regulator

## PROTECTION DIODES

Under normal operation, the LM1085 regulator does not need any protection diode. With the adjustable device, the internal resistance between the adjustment and output terminals limits the current. No diode is needed to divert the current around the regulator even with a capacitor on the adjustment terminal. The adjust pin can take a transient signal of  $\pm 25V$  with respect to the output voltage without damaging the device.

When an output capacitor is connected to a regulator and the input is shorted, the output capacitor will discharge into the output of the regulator. The discharge current depends on the value of the capacitor, the output voltage of the regulator, and rate of decrease of  $V_{IN}$ . In the LM1085 regulator, the internal diode between the output and input pins can withstand microsecond surge currents of 10A to 20A. With an extremely large output capacitor ( $\geq 1000 \mu f$ ), and with input instantaneously shorted to ground, the regulator could be damaged. In this case, an external diode is recommended between the output and input pins to protect the regulator, shown in Figure 19.

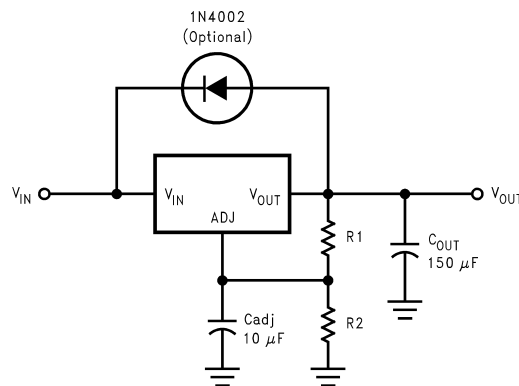

Figure 19. Regulator with Protection Diode

## OVERLOAD RECOVERY

Overload recovery refers to regulator's ability to recover from a short circuited output. A key factor in the recovery process is the current limiting used to protect the output from drawing too much power. The current limiting circuit reduces the output current as the input to output differential increases. Refer to short circuit curve in the [Typical Performance Characteristics](#) section.

During normal start-up, the input to output differential is small since the output follows the input. But, if the output is shorted, then the recovery involves a large input to output differential. Sometimes during this condition the current limiting circuit is slow in recovering. If the limited current is too low to develop a voltage at the output, the voltage will stabilize at a lower level. Under these conditions it may be necessary to recycle the power of the regulator in order to get the smaller differential voltage and thus adequate start up conditions. Refer to [Typical Performance Characteristics](#) section for the short circuit current vs. input differential voltage.

## THERMAL CONSIDERATIONS FOR THE TO-220 PACKAGE

ICs heats up when in operation, and power consumption is one factor in how hot it gets. The other factor is how well the heat is dissipated. Heat dissipation is predictable by knowing the thermal resistance between the IC and ambient ( $\theta_{JA}$ ). Thermal resistance has units of temperature per power ( $^{\circ}\text{C}/\text{W}$ ). The higher the thermal resistance, the hotter the IC.

The LM1085 specifies the thermal resistance for the TO-220 package as Junction to Case ( $\theta_{JC}$ ). In order to get the total resistance to ambient ( $\theta_{JA}$ ), two other thermal resistances must be added, one for case to heat-sink ( $\theta_{CH}$ ) and one for heatsink to ambient ( $\theta_{HA}$ ). The junction temperature can be predicted as follows:

$$T_J = T_A + (P_D \times (\theta_{JC} + \theta_{CH} + \theta_{HA})) \quad (1)$$

$$T_J = T_A + (P_D \times \theta_{JA}) \quad (2)$$

where  $T_J$  is junction temperature,  $T_A$  is ambient temperature, and  $P_D$  is the power dissipation of the device.

Device power dissipation is calculated as follows:

$$P_D = \text{OUTPUT Section Dissipation} + \text{CONTROL Section Dissipation} \quad (3)$$

$$P_D = (V_{IN} - V_{OUT}) \times I_{LOAD} + (V_{IN} - V_{OUT}) \times I_{GND} \quad (4)$$

Figure 20 shows the voltages and currents which are present in the circuit.

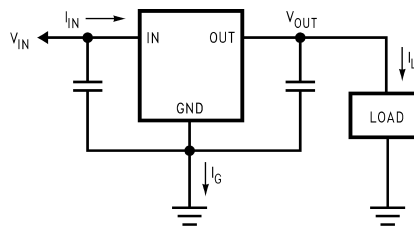

**Figure 20. Power Dissipation Diagram**

Once the devices power is determined, the maximum allowable ( $\theta_{JA(max)}$ ) is calculated as:

$$\theta_{JA(MAX)} = T_{R(MAX)} / P_D \quad (5)$$

$$\theta_{JA(MAX)} = T_{J(MAX)} - T_{A(MAX)} / P_D \quad (6)$$

The required heat sink is determined by calculating its required thermal resistance ( $\theta_{HA(MAX)}$ ).

$$\theta_{HA(MAX)} = \theta_{JA(MAX)} - (\theta_{JC} + \theta_{CH}) \quad (7)$$

If thermal compound is used,  $\theta_{CH}$  can be estimated at 0.2 C/W. If the case is soldered to the heat sink, then a  $\theta_{CH}$  can be estimated as 0 C/W.

If PC board copper is going to be used as a heat sink, then Figure 21 can be used to determine the appropriate area (size) of copper foil required.

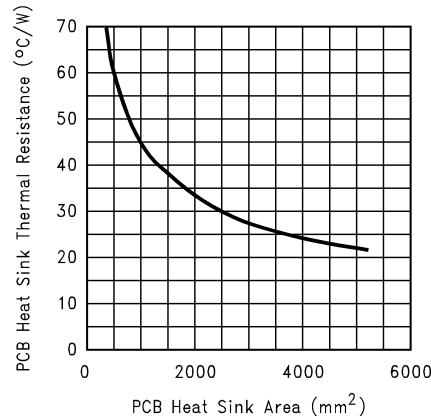

Figure 21. Heat sink thermal Resistance vs Area

### THERMAL CONSIDERATION FOR THE DDPAK/TO-263 PACKAGE

Unlike the TO-220 package, the TO-263 package uses the printed circuit board as the heat sink to remove heat from the device. The device dissipation is:

$$P_D = \text{OUTPUT Section Dissipation} + \text{CONTROL Section Dissipation} \quad (8)$$

For the LM1085IS-x.x pre-set voltage versions, the dissipation can be calculated using:

$$P_D = (V_{IN} - V_{OUT}) \times I_{LOAD} + (V_{IN} - V_{OUT}) \times I_{GND} \quad (9)$$

The LM1085IS-ADJ adjustable voltage version, the dissipation can be calculated using:

$$P_D = (V_{IN} - V_{OUT}) \times I_{LOAD} + (V_{IN} - V_{OUT}) \times (V_{REF} / R1) \quad (10)$$

Current through the ADJ pin is sufficiently small such that any contribution to the device dissipation is so low that it can safely be ignored.

Maximum power dissipation of the LM1085IS depends on the total thermal resistance from the silicon junction through the package TAB ( $\theta_{JC}$ ), into the PC board, copper traces, and other materials, and then into the surrounding air ( $\theta_{JA}$ ), the maximum allowed operating junction temperature ( $T_{J(MAX)}$ ) of 125°C, and the maximum ambient temperature ( $T_{A(MAX)}$ ). The maximum power dissipation in the device is:

$$P_{D(MAX)} = (T_{J(MAX)} - T_{A(MAX)}) / \theta_{JA} \quad (11)$$

For the LM1085IS in the DDPAK/TO-263 3-pin package, the junction-to-case thermal rating,  $\theta_{JC}$ , is 0.7°C/W, where the case is the bottom of the package at the center of the TAB. Typical junction-to-ambient thermal performance for the LM1085IS, using the JESD51 standards, is summarized in the following table:

BOARD TYPE	THERMAL VIAS	$\theta_{JA}$
JEDEC 2-Layer (per JESD 51-3)	None	81 °C/W
	0	59 °C/W
JEDEC 4-Layer (per JESD 51-7)	2	31 °C/W
	4	27 °C/W
	8	24 °C/W
	12	23 °C/W

For more information refer to : “Application Note 1520 A Guide to Board Layout for Best Thermal Resistance for Exposed Packages”, TI Literature Number: [SNVA183](#)

It is important to remember that the TAB of the LM1085IS package is internally connected to device pin 2 (OUTPUT), so the copper area connected to the TAB must be isolated from all other potentials, including ground. The copper area connected to the TAB can be left floating, used as the primary  $V_{OUT}$  connection, or connected to device pin 2 (OUTPUT) .

**Typical Applications**

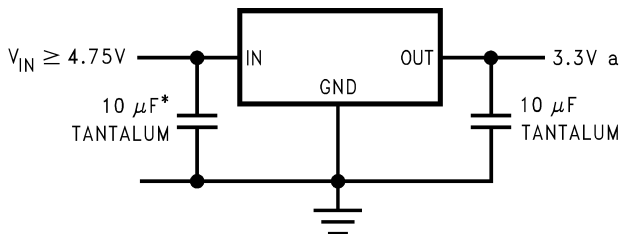

\*MAY BE OMITTED IF INPUT SUPPLY IS WELL BYPASSED WITHIN 2" OF THE LM1085

**Figure 22. 5V to 3.3V, 1.5A Regulator**



\*REQUIRED FOR STABILITY

**Figure 23. Adjustable @ 5V**

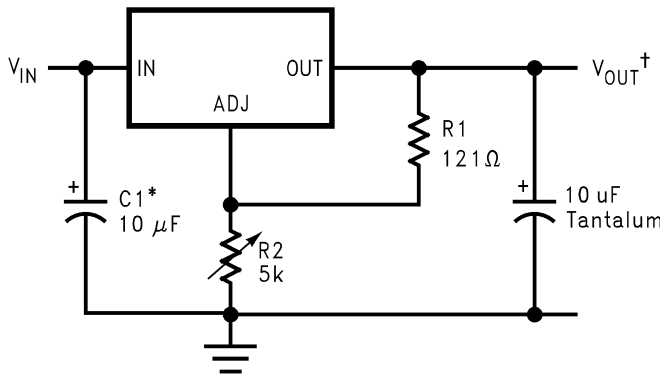

\*NEEDED IF DEVICE IS FAR FROM FILTER CAPACITORS

$$†V_{OUT} = 1.25V \left(1 + \frac{R2}{R1}\right)$$

**Figure 24. 1.2V to 15V Adjustable Regulator**

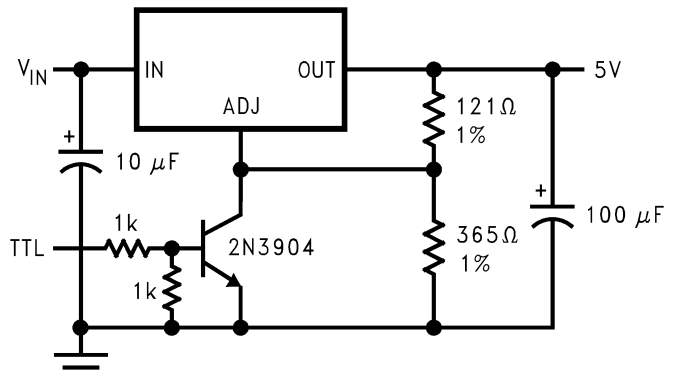

**Figure 25. 5V Regulator with Shutdown**

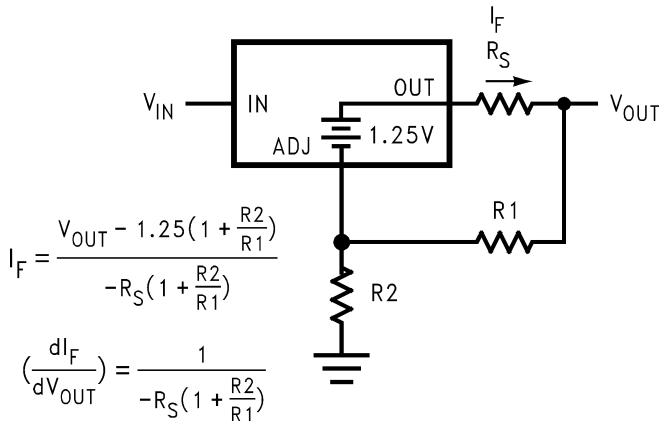

**Figure 26. Battery Charger**

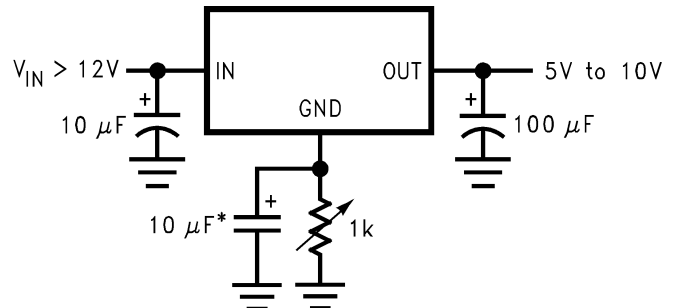

\*OPTIONAL IMPROVES RIPPLE REJECTION

**Figure 27. Adjustable Fixed Regulator**

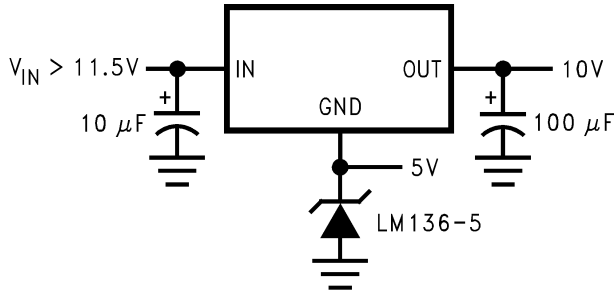

Figure 28. Regulator with Reference

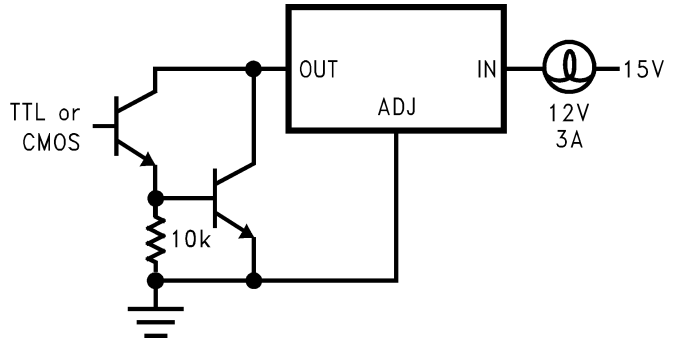

Figure 29. High Current Lamp Driver Protection

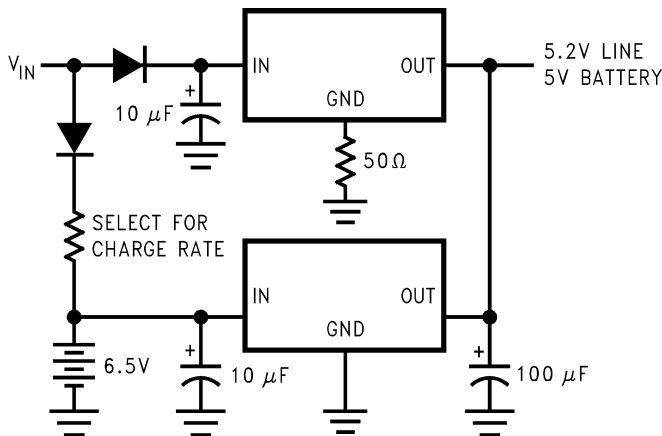
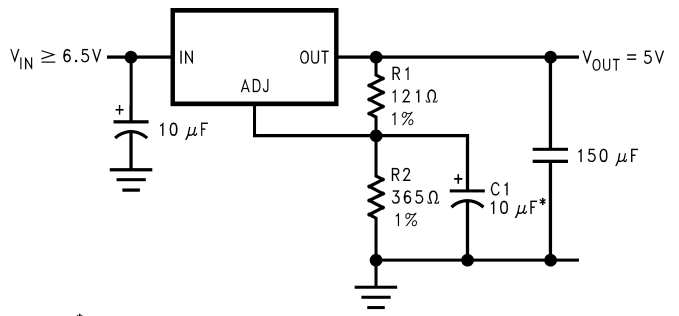

Figure 30. Battery Backup Regulated Supply



\*C1 IMPROVES RIPPLE REJECTION.  
X<sub>C</sub> SHOULD BE ≈ R1 AT RIPPLE FREQUENCY

Figure 31. Ripple Rejection Enhancement

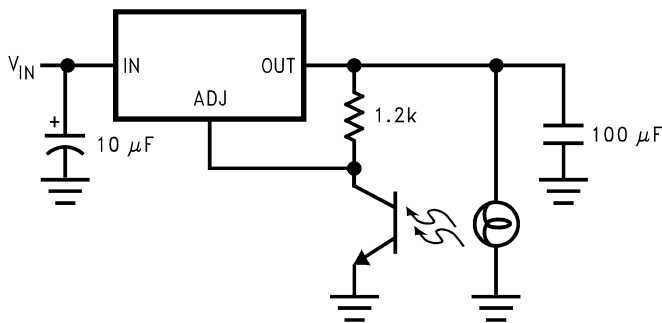

Figure 32. Automatic Light control

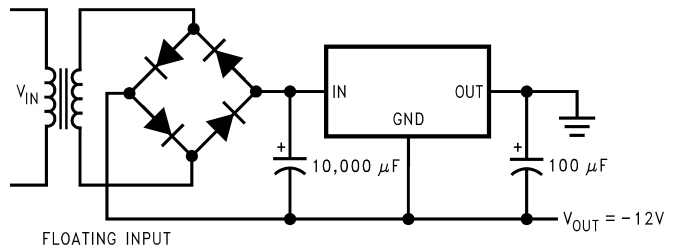

Figure 33. Generating Negative Supply voltage



---

**REVISION HISTORY**

<b>Changes from Revision F (March 2013) to Revision G</b>	<b>Page</b>
<hr/> <ul style="list-style-type: none"><li>Deleted layout of National Data Sheet to TI format .....</li></ul> <hr/>	<hr/> <a href="#">14</a> <hr/>

**PACKAGING INFORMATION**

Orderable Device	Status (1)	Package Type	Package Drawing	Pins	Package Qty	Eco Plan (2)	Lead/Ball Finish	MSL Peak Temp (3)	Op Temp (°C)	Top-Side Markings (4)	Samples
LM1085IS-12/NOPB	ACTIVE	DDPAK/ TO-263	KTT	3	45	Pb-Free (RoHS Exempt)	CU SN	Level-3-245C-168 HR	-40 to 125	LM1085 IS-12	<a href="#">Samples</a>
LM1085IS-3.3	ACTIVE	DDPAK/ TO-263	KTT	3	45	TBD	Call TI	Call TI	-40 to 125	LM1085 IS-3.3	<a href="#">Samples</a>
LM1085IS-3.3/NOPB	ACTIVE	DDPAK/ TO-263	KTT	3	45	Pb-Free (RoHS Exempt)	CU SN	Level-3-245C-168 HR	-40 to 125	LM1085 IS-3.3	<a href="#">Samples</a>
LM1085IS-5.0/NOPB	ACTIVE	DDPAK/ TO-263	KTT	3	45	Pb-Free (RoHS Exempt)	CU SN	Level-3-245C-168 HR	-40 to 125	LM1085 IS-5.0	<a href="#">Samples</a>
LM1085IS-ADJ	ACTIVE	DDPAK/ TO-263	KTT	3	45	TBD	Call TI	Call TI	-40 to 125	LM1085 IS-ADJ	<a href="#">Samples</a>
LM1085IS-ADJ/NOPB	ACTIVE	DDPAK/ TO-263	KTT	3	45	Pb-Free (RoHS Exempt)	CU SN	Level-3-245C-168 HR	-40 to 125	LM1085 IS-ADJ	<a href="#">Samples</a>
LM1085ISX-3.3	ACTIVE	DDPAK/ TO-263	KTT	3	500	TBD	Call TI	Call TI	-40 to 125	LM1085 IS-3.3	<a href="#">Samples</a>
LM1085ISX-3.3/NOPB	ACTIVE	DDPAK/ TO-263	KTT	3	500	Pb-Free (RoHS Exempt)	CU SN	Level-3-245C-168 HR	-40 to 125	LM1085 IS-3.3	<a href="#">Samples</a>
LM1085ISX-5.0/NOPB	ACTIVE	DDPAK/ TO-263	KTT	3	500	Pb-Free (RoHS Exempt)	CU SN	Level-3-245C-168 HR	-40 to 125	LM1085 IS-5.0	<a href="#">Samples</a>
LM1085ISX-ADJ	ACTIVE	DDPAK/ TO-263	KTT	3	500	TBD	Call TI	Call TI	-40 to 125	LM1085 IS-ADJ	<a href="#">Samples</a>
LM1085ISX-ADJ/NOPB	ACTIVE	DDPAK/ TO-263	KTT	3	500	Pb-Free (RoHS Exempt)	CU SN	Level-3-245C-168 HR	-40 to 125	LM1085 IS-ADJ	<a href="#">Samples</a>
LM1085IT-12/NOPB	ACTIVE	TO-220	NDE	3	45	Green (RoHS & no Sb/Br)	CU SN	Level-1-NA-UNLIM	-40 to 125	LM1085 IT-12	<a href="#">Samples</a>
LM1085IT-3.3/NOPB	ACTIVE	TO-220	NDE	3	45	Green (RoHS & no Sb/Br)	CU SN	Level-1-NA-UNLIM	-40 to 125	LM1085 IT-3.3	<a href="#">Samples</a>
LM1085IT-5.0	ACTIVE	TO-220	NDE	3	45	TBD	Call TI	Call TI	-40 to 125	LM1085 IT-5.0	<a href="#">Samples</a>
LM1085IT-5.0/NOPB	ACTIVE	TO-220	NDE	3	45	Green (RoHS & no Sb/Br)	CU SN	Level-1-NA-UNLIM	-40 to 125	LM1085 IT-5.0	<a href="#">Samples</a>
LM1085IT-ADJ	ACTIVE	TO-220	NDE	3	45	TBD	Call TI	Call TI	-40 to 125	LM1085 IT-ADJ	<a href="#">Samples</a>
LM1085IT-ADJ/NOPB	ACTIVE	TO-220	NDE	3	45	Green (RoHS & no Sb/Br)	CU SN	Level-1-NA-UNLIM	-40 to 125	LM1085 IT-ADJ	<a href="#">Samples</a>

(1) The marketing status values are defined as follows:

**ACTIVE:** Product device recommended for new designs.

**LIFEBUY:** TI has announced that the device will be discontinued, and a lifetime-buy period is in effect.

**NRND:** Not recommended for new designs. Device is in production to support existing customers, but TI does not recommend using this part in a new design.

**PREVIEW:** Device has been announced but is not in production. Samples may or may not be available.

**OBSOLETE:** TI has discontinued the production of the device.

(2) Eco Plan - The planned eco-friendly classification: Pb-Free (RoHS), Pb-Free (RoHS Exempt), or Green (RoHS & no Sb/Br) - please check <http://www.ti.com/productcontent> for the latest availability information and additional product content details.

**TBD:** The Pb-Free/Green conversion plan has not been defined.

**Pb-Free (RoHS):** TI's terms "Lead-Free" or "Pb-Free" mean semiconductor products that are compatible with the current RoHS requirements for all 6 substances, including the requirement that lead not exceed 0.1% by weight in homogeneous materials. Where designed to be soldered at high temperatures, TI Pb-Free products are suitable for use in specified lead-free processes.

**Pb-Free (RoHS Exempt):** This component has a RoHS exemption for either 1) lead-based flip-chip solder bumps used between the die and package, or 2) lead-based die adhesive used between the die and leadframe. The component is otherwise considered Pb-Free (RoHS compatible) as defined above.

**Green (RoHS & no Sb/Br):** TI defines "Green" to mean Pb-Free (RoHS compatible), and free of Bromine (Br) and Antimony (Sb) based flame retardants (Br or Sb do not exceed 0.1% by weight in homogeneous material)

(3) MSL, Peak Temp. -- The Moisture Sensitivity Level rating according to the JEDEC industry standard classifications, and peak solder temperature.

(4) Multiple Top-Side Markings will be inside parentheses. Only one Top-Side Marking contained in parentheses and separated by a "~" will appear on a device. If a line is indented then it is a continuation of the previous line and the two combined represent the entire Top-Side Marking for that device.

**Important Information and Disclaimer:** The information provided on this page represents TI's knowledge and belief as of the date that it is provided. TI bases its knowledge and belief on information provided by third parties, and makes no representation or warranty as to the accuracy of such information. Efforts are underway to better integrate information from third parties. TI has taken and continues to take reasonable steps to provide representative and accurate information but may not have conducted destructive testing or chemical analysis on incoming materials and chemicals. TI and TI suppliers consider certain information to be proprietary, and thus CAS numbers and other limited information may not be available for release.

In no event shall TI's liability arising out of such information exceed the total purchase price of the TI part(s) at issue in this document sold by TI to Customer on an annual basis.

**TAPE AND REEL INFORMATION**

**QUADRANT ASSIGNMENTS FOR PIN 1 ORIENTATION IN TAPE**

\*All dimensions are nominal

Device	Package Type	Package Drawing	Pins	SPQ	Reel Diameter (mm)	Reel Width W1 (mm)	A0 (mm)	B0 (mm)	K0 (mm)	P1 (mm)	W (mm)	Pin1 Quadrant
LM1085ISX-3.3	DDPAK/ TO-263	KTT	3	500	330.0	24.4	10.75	14.85	5.0	16.0	24.0	Q2
LM1085ISX-3.3/NOPB	DDPAK/ TO-263	KTT	3	500	330.0	24.4	10.75	14.85	5.0	16.0	24.0	Q2
LM1085ISX-5.0/NOPB	DDPAK/ TO-263	KTT	3	500	330.0	24.4	10.75	14.85	5.0	16.0	24.0	Q2
LM1085ISX-ADJ	DDPAK/ TO-263	KTT	3	500	330.0	24.4	10.75	14.85	5.0	16.0	24.0	Q2
LM1085ISX-ADJ/NOPB	DDPAK/ TO-263	KTT	3	500	330.0	24.4	10.75	14.85	5.0	16.0	24.0	Q2

**TAPE AND REEL BOX DIMENSIONS**



\*All dimensions are nominal

Device	Package Type	Package Drawing	Pins	SPQ	Length (mm)	Width (mm)	Height (mm)
LM1085ISX-3.3	DDPAK/TO-263	KTT	3	500	367.0	367.0	45.0
LM1085ISX-3.3/NOPB	DDPAK/TO-263	KTT	3	500	367.0	367.0	45.0
LM1085ISX-5.0/NOPB	DDPAK/TO-263	KTT	3	500	367.0	367.0	45.0
LM1085ISX-ADJ	DDPAK/TO-263	KTT	3	500	367.0	367.0	45.0
LM1085ISX-ADJ/NOPB	DDPAK/TO-263	KTT	3	500	367.0	367.0	45.0

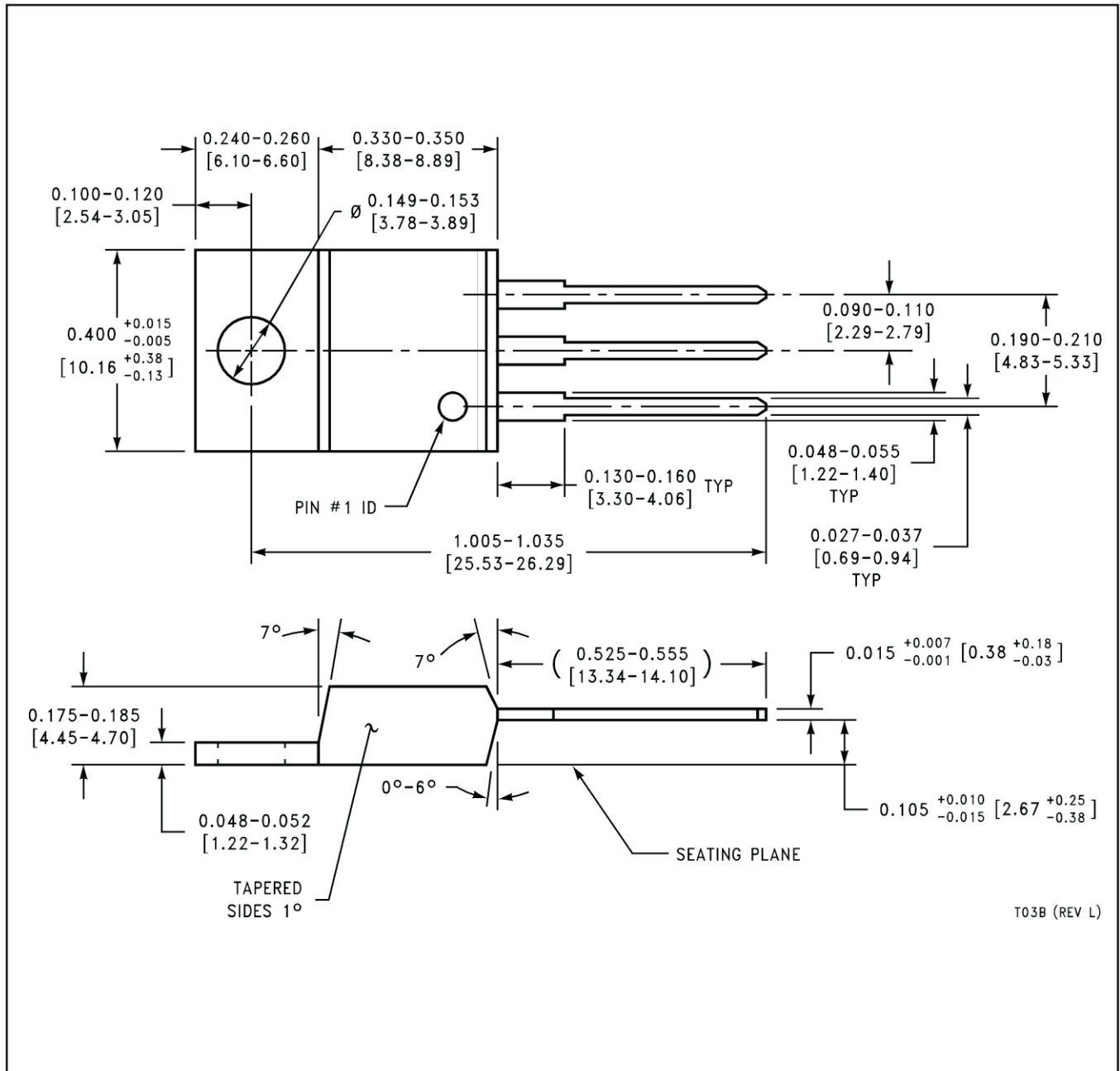
NDE0003B

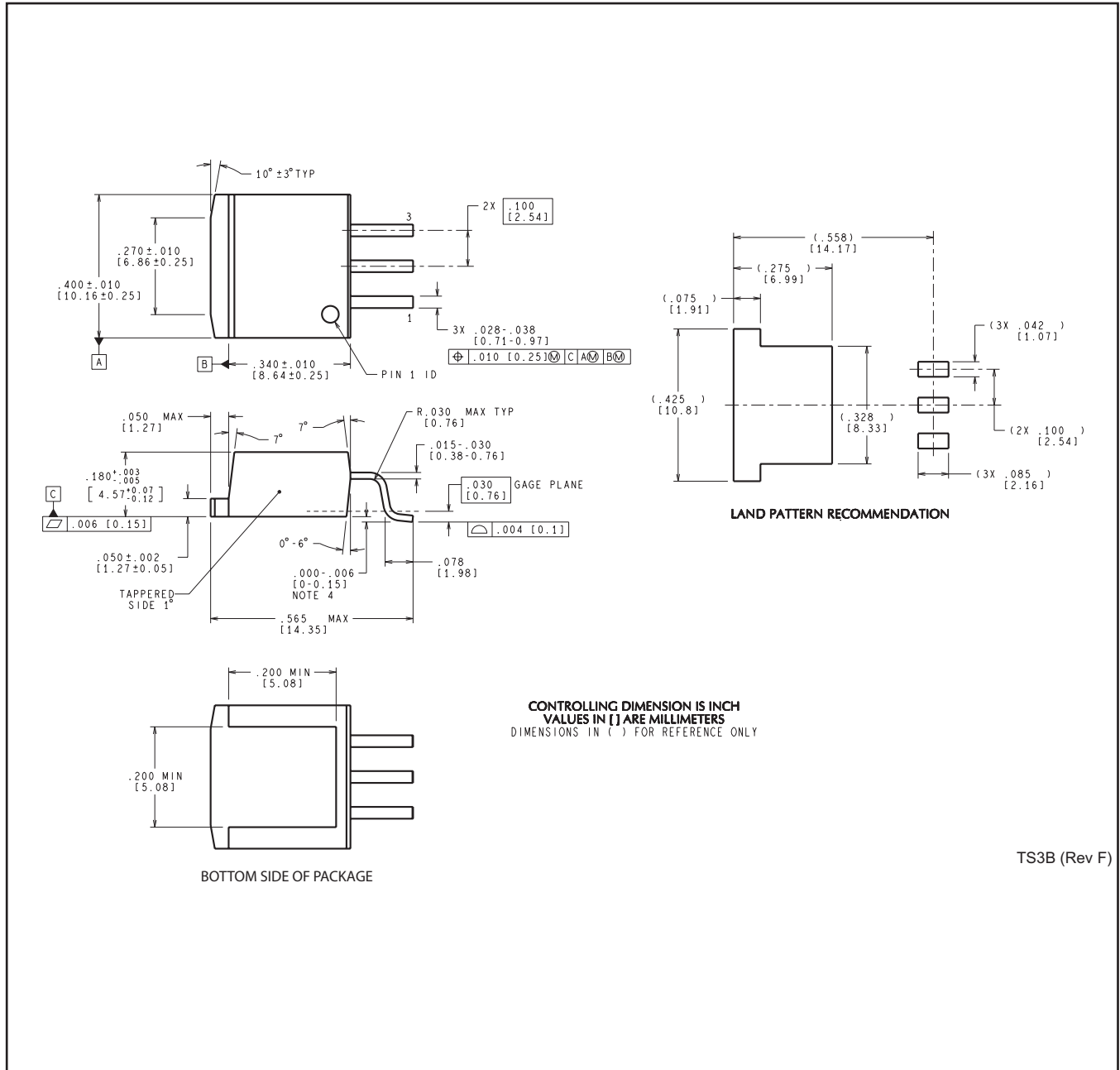

KTT0003B



## IMPORTANT NOTICE

Texas Instruments Incorporated and its subsidiaries (TI) reserve the right to make corrections, enhancements, improvements and other changes to its semiconductor products and services per JESD46, latest issue, and to discontinue any product or service per JESD48, latest issue. Buyers should obtain the latest relevant information before placing orders and should verify that such information is current and complete. All semiconductor products (also referred to herein as "components") are sold subject to TI's terms and conditions of sale supplied at the time of order acknowledgment.

TI warrants performance of its components to the specifications applicable at the time of sale, in accordance with the warranty in TI's terms and conditions of sale of semiconductor products. Testing and other quality control techniques are used to the extent TI deems necessary to support this warranty. Except where mandated by applicable law, testing of all parameters of each component is not necessarily performed.

TI assumes no liability for applications assistance or the design of Buyers' products. Buyers are responsible for their products and applications using TI components. To minimize the risks associated with Buyers' products and applications, Buyers should provide adequate design and operating safeguards.

TI does not warrant or represent that any license, either express or implied, is granted under any patent right, copyright, mask work right, or other intellectual property right relating to any combination, machine, or process in which TI components or services are used. Information published by TI regarding third-party products or services does not constitute a license to use such products or services or a warranty or endorsement thereof. Use of such information may require a license from a third party under the patents or other intellectual property of the third party, or a license from TI under the patents or other intellectual property of TI.

Reproduction of significant portions of TI information in TI data books or data sheets is permissible only if reproduction is without alteration and is accompanied by all associated warranties, conditions, limitations, and notices. TI is not responsible or liable for such altered documentation. Information of third parties may be subject to additional restrictions.

Resale of TI components or services with statements different from or beyond the parameters stated by TI for that component or service voids all express and any implied warranties for the associated TI component or service and is an unfair and deceptive business practice. TI is not responsible or liable for any such statements.

Buyer acknowledges and agrees that it is solely responsible for compliance with all legal, regulatory and safety-related requirements concerning its products, and any use of TI components in its applications, notwithstanding any applications-related information or support that may be provided by TI. Buyer represents and agrees that it has all the necessary expertise to create and implement safeguards which anticipate dangerous consequences of failures, monitor failures and their consequences, lessen the likelihood of failures that might cause harm and take appropriate remedial actions. Buyer will fully indemnify TI and its representatives against any damages arising out of the use of any TI components in safety-critical applications.

In some cases, TI components may be promoted specifically to facilitate safety-related applications. With such components, TI's goal is to help enable customers to design and create their own end-product solutions that meet applicable functional safety standards and requirements. Nonetheless, such components are subject to these terms.

No TI components are authorized for use in FDA Class III (or similar life-critical medical equipment) unless authorized officers of the parties have executed a special agreement specifically governing such use.

Only those TI components which TI has specifically designated as military grade or "enhanced plastic" are designed and intended for use in military/aerospace applications or environments. Buyer acknowledges and agrees that any military or aerospace use of TI components which have **not** been so designated is solely at the Buyer's risk, and that Buyer is solely responsible for compliance with all legal and regulatory requirements in connection with such use.

TI has specifically designated certain components as meeting ISO/TS16949 requirements, mainly for automotive use. In any case of use of non-designated products, TI will not be responsible for any failure to meet ISO/TS16949.

### Products

Audio	<a href="http://www.ti.com/audio">www.ti.com/audio</a>
Amplifiers	<a href="http://amplifier.ti.com">amplifier.ti.com</a>
Data Converters	<a href="http://dataconverter.ti.com">dataconverter.ti.com</a>
DLP® Products	<a href="http://www.dlp.com">www.dlp.com</a>
DSP	<a href="http://dsp.ti.com">dsp.ti.com</a>
Clocks and Timers	<a href="http://www.ti.com/clocks">www.ti.com/clocks</a>
Interface	<a href="http://interface.ti.com">interface.ti.com</a>
Logic	<a href="http://logic.ti.com">logic.ti.com</a>
Power Mgmt	<a href="http://power.ti.com">power.ti.com</a>
Microcontrollers	<a href="http://microcontroller.ti.com">microcontroller.ti.com</a>
RFID	<a href="http://www.ti-rfid.com">www.ti-rfid.com</a>
OMAP Applications Processors	<a href="http://www.ti.com/omap">www.ti.com/omap</a>
Wireless Connectivity	<a href="http://www.ti.com/wirelessconnectivity">www.ti.com/wirelessconnectivity</a>

### Applications

Automotive and Transportation	<a href="http://www.ti.com/automotive">www.ti.com/automotive</a>
Communications and Telecom	<a href="http://www.ti.com/communications">www.ti.com/communications</a>
Computers and Peripherals	<a href="http://www.ti.com/computers">www.ti.com/computers</a>
Consumer Electronics	<a href="http://www.ti.com/consumer-apps">www.ti.com/consumer-apps</a>
Energy and Lighting	<a href="http://www.ti.com/energy">www.ti.com/energy</a>
Industrial	<a href="http://www.ti.com/industrial">www.ti.com/industrial</a>
Medical	<a href="http://www.ti.com/medical">www.ti.com/medical</a>
Security	<a href="http://www.ti.com/security">www.ti.com/security</a>
Space, Avionics and Defense	<a href="http://www.ti.com/space-avionics-defense">www.ti.com/space-avionics-defense</a>
Video and Imaging	<a href="http://www.ti.com/video">www.ti.com/video</a>

### TI E2E Community

[e2e.ti.com](http://e2e.ti.com)