

## LM111JAN Voltage Comparator

 Check for Samples: [LM111JAN](#)

### FEATURES

- Operates from Single 5V Supply
- Input Current: 200 nA max. Over Temperature
- Offset Current: 20 nA max. Over Temperature
- Differential Input Voltage Range:  $\pm 30V$
- Power Consumption: 135 mW at  $\pm 15V$
- Power Supply Voltage, single 5V to  $\pm 15V$
- Offset Voltage Null Capability
- Strobe Capability

### DESCRIPTION

The LM111 is a voltage comparator that has input currents nearly a thousand times lower than devices such as the LM106 or LM710. It is also designed to operate over a wider range of supply voltages: from standard  $\pm 15V$  op amp supplies down to the single 5V supply used for IC logic. The output is compatible with RTL, DTL and TTL as well as MOS circuits. Further, it can drive lamps or relays, switching voltages up to 50V at currents as high as 50 mA.

Both the inputs and the outputs of the LM111 can be isolated from system ground, and the output can drive loads referred to ground, the positive supply or the negative supply. Offset balancing and strobe capability are provided and outputs can be wire OR'ed. Although slower than the LM106 and LM710 (200 ns response time vs 40 ns) the device is also much less prone to spurious oscillations. The LM111 has the same pin configuration as the LM106 and LM710.

### Connection Diagrams

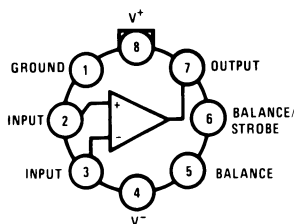

Note: Pin 4 connected to case

**Figure 1. Metal Can Package  
Top View  
See Package Number LMC0008C**

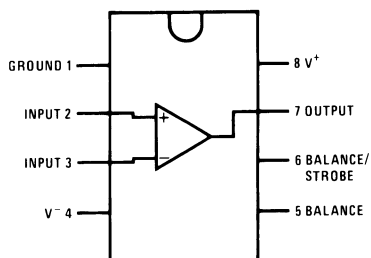

**Figure 2. Dual-In-Line Package  
Top View  
See Package Number NAB0008A**

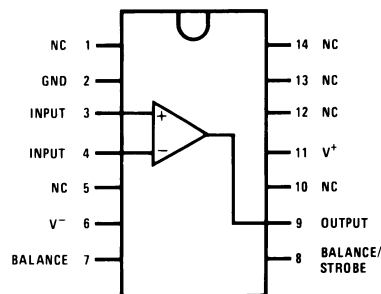

**Figure 3. Dual-In-Line Package  
Top View  
See Package Number J0014A**



Please be aware that an important notice concerning availability, standard warranty, and use in critical applications of Texas Instruments semiconductor products and disclaimers thereto appears at the end of this data sheet.

All trademarks are the property of their respective owners.

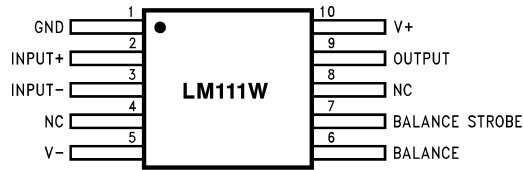
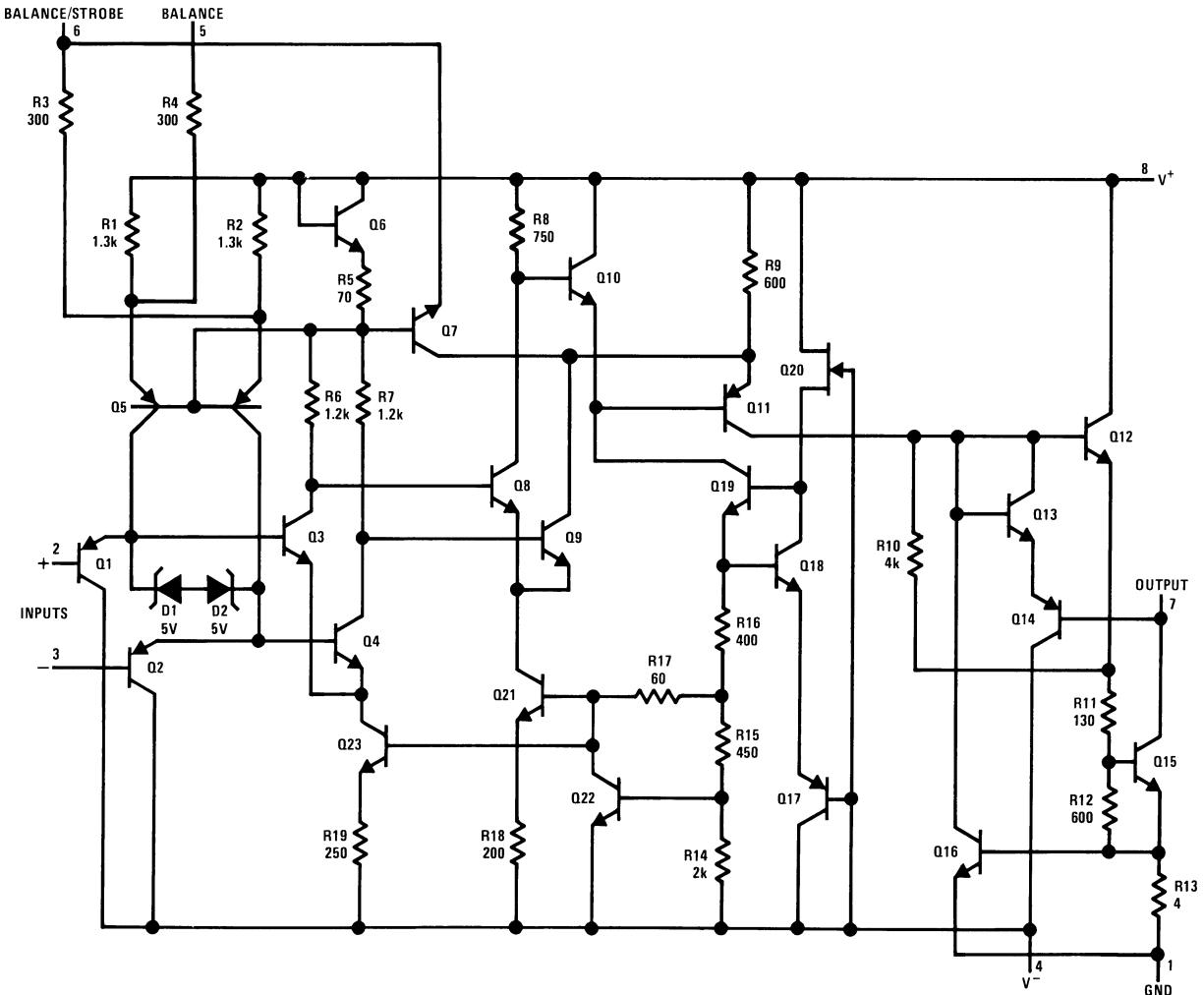

Figure 4. See Package Number NAD0010A, NAC0010A

Schematic Diagram



Note: Pin connections shown on schematic diagram are for LMC0008C package.



These devices have limited built-in ESD protection. The leads should be shorted together or the device placed in conductive foam during storage or handling to prevent electrostatic damage to the MOS gates.

**Absolute Maximum Ratings<sup>(1)</sup>**

Positive Supply Voltage		+30.0V	
Negative Supply Voltage		-30.0V	
Total Supply Voltage		36V	
Output to Negative Supply Voltage		50V	
GND to Negative Supply Voltage		30V	
Differential Input Voltage		±30V	
Sink Current		50mA	
Input Voltage <sup>(2)</sup>		±15V	
Power Dissipation <sup>(3)</sup>	8 LD CERDIP	400mW @ 25°C	
	8 LD Metal Can	330mW @ 25°C	
	10 LD CERPACK	330mW @ 25°C	
	10 LD Ceramic SOIC	330mW @ 25°C	
	14 LD CERDIP	400mW @ 25°C	
Output Short Circuit Duration		10 seconds	
Maximum Strobe Current		10mA	
Operating Temperature Range		-55°C ≤ T <sub>A</sub> ≤ 125°C	
Thermal Resistance	θ <sub>JA</sub>	8 LD CERDIP (Still Air @ 0.5W)	120°C/W
		8 LD CERDIP (500LF/Min Air flow @ 0.5W)	76°C/W
		8 LD Metal Can (Still Air @ 0.5W)	150°C/W
		8 LD Metal Can (500LF/Min Air flow @ 0.5W)	92°C/W
		10 Ceramic SOIC (Still Air @ 0.5W)	231°C/W
		10 Ceramic SOIC (500LF/Min Air flow @ 0.5W)	153°C/W
		10 CERPACK (Still Air @ 0.5W)	231°C/W
		10 CERPACK (500LF/Min Air flow @ 0.5W)	153°C/W
		14 LD CERDIP (Still Air @ 0.5W)	120°C/W
		14 LD CERDIP (500LF/Min Air flow @ 0.5W)	65°C/W
	θ <sub>JC</sub>	8 LD CERDIP	35°C/W
		8 LD Metal Can Pkg	40°C/W
		10 LD Ceramic SOIC	60°C/W
		10 LD CERPACK	60°C/W
14 LD CERDIP		35°C/W	
Storage Temperature Range		-65°C ≤ T <sub>A</sub> ≤ 150°C	
Maximum Junction Temperature		175°C	
Lead Temperature (Soldering, 60 seconds)		300°C	
Voltage at Strobe Pin		V <sup>+</sup> -5V	
Package Weight (Typical)	8 LD Metal Can	965mg	
	8 LD CERDIP	1100mg	
	10 LD CERPACK	250mg	
	10 LD Ceramic SOIC	225mg	
	14 LD CERDIP	TBD	
ESD Rating <sup>(4)</sup>		300V	

- (1) Absolute Maximum Ratings indicate limits beyond which damage to the device may occur. Operating Ratings indicate conditions for which the device is functional, but do not ensure specific performance limits. For ensured specifications and test conditions, see the Electrical Characteristics. The ensured specifications apply only for the test conditions listed. Some performance characteristics may degrade when the device is not operated under the listed test conditions.
- (2) This rating applies for ±15V supplies. The positive input voltage limit is 30 V above the negative supply. The negative input voltage limit is equal to the negative supply voltage or 30V below the positive supply, whichever is less.
- (3) The maximum power dissipation must be derated at elevated temperatures and is dictated by T<sub>Jmax</sub> (maximum junction temperature), θ<sub>JA</sub> (package junction to ambient thermal resistance), and T<sub>A</sub> (ambient temperature). The maximum allowable power dissipation at any temperature is P<sub>Dmax</sub> = (T<sub>Jmax</sub> - T<sub>A</sub>)/θ<sub>JA</sub> or the number given in the Absolute Maximum Ratings, whichever is lower.
- (4) Human body model, 1.5 kΩ in series with 100 pF.

## Recommended Operating Conditions

Supply Voltage	$V_{CC} = \pm 15V_{DC}$
Operating Temperature Range	$-55^{\circ}C \leq T_A \leq 125^{\circ}C$

## Quality Conformance Inspection

Mil-Std-883, Method 5005 — Group A

Subgroup	Description	Temperature (°C)
1	Static tests at	+25
2	Static tests at	+125
3	Static tests at	-55
4	Dynamic tests at	+25
5	Dynamic tests at	+125
6	Dynamic tests at	-55
7	Functional tests at	+25
8A	Functional tests at	+125
8B	Functional tests at	-55
9	Switching tests at	+25
10	Switching tests at	+125
11	Switching tests at	-55

## LM111 JAN Electrical Characteristics DC Parameters

The following conditions apply, unless otherwise specified.

DC:  $V_{CC} = \pm 15V$ ,  $V_{CM} = 0$ 

Symbol	Parameter	Conditions	Notes	Min	Max	Unit	Sub-groups
$V_{IO}$	Input Offset Voltage	$V_I = 0V$ , $R_S = 50\Omega$		-3.0	+3.0	mV	1
				-4.0	+4.0	mV	2, 3
		$+V_{CC} = 29.5V$ , $-V_{CC} = -0.5V$ , $V_I = 0V$ , $V_{CM} = -14.5V$ , $R_S = 50\Omega$		-3.0	+3.0	mV	1
				-4.0	+4.0	mV	2, 3
		$+V_{CC} = 2V$ , $-V_{CC} = -28V$ , $V_I = 0V$ , $V_{CM} = +13V$ , $R_S = 50\Omega$		-3.0	+3.0	mV	1
	-4.0	+4.0	mV	2, 3			
$V_{IO R}$	Raised Input Offset Voltage	$V_I = 0V$ , $R_S = 50\Omega$	See <sup>(1)</sup>	-3.0	+3.0	mV	1
				-4.5	+4.5	mV	2, 3
		$+V_{CC} = 29.5V$ , $-V_{CC} = -0.5V$ , $V_I = 0V$ , $V_{CM} = -14.5V$ , $R_S = 50\Omega$	See <sup>(1)</sup>	-3.0	+3.0	mV	1
				-4.5	+4.5	mV	2, 3
		$+V_{CC} = 2V$ , $-V_{CC} = -28V$ , $V_I = 0V$ , $V_{CM} = +13V$ , $R_S = 50\Omega$	See <sup>(1)</sup>	-3.0	+3.0	mV	1
				-4.5	+4.5	mV	2, 3
$I_{IO}$	Input Offset Current	$V_I = 0V$ , $R_S = 50K\Omega$		-10	+10	nA	1, 2
				-20	+20	nA	3
		$+V_{CC} = 29.5V$ , $-V_{CC} = -0.5V$ , $V_I = 0V$ , $V_{CM} = -14.5V$ , $R_S = 50K\Omega$		-10	+10	nA	1, 2
				-20	+20	nA	3
		$+V_{CC} = 2V$ , $-V_{CC} = -28V$ , $V_I = 0V$ , $V_{CM} = +13V$ , $R_S = 50K\Omega$		-10	+10	nA	1, 2
	-20	+20	nA	3			

(1) Subscript (R) indicates tests which are performed with input stage current raised by connecting BAL and BAL/STB terminals to  $+V_{CC}$ .

**LM111 JAN Electrical Characteristics DC Parameters (continued)**

The following conditions apply, unless otherwise specified.

 DC:  $V_{CC} = \pm 15V$ ,  $V_{CM} = 0$ 

Symbol	Parameter	Conditions	Notes	Min	Max	Unit	Sub-groups	
$I_{IO}R$	Raised Input Offset Current	$V_I = 0V$ , $R_S = 50K\Omega$	See <sup>(1)</sup>	-25	+25	nA	1, 2	
				-50	+50	nA	3	
$\pm I_{IB}$	Input Bias Current	$V_I = 0V$ , $R_S = 50K\Omega$		-100	0.1	nA	1, 2	
				-150	0.1	nA	3	
				+ $V_{CC} = 29.5V$ , - $V_{CC} = -0.5V$ , $V_I = 0V$ , $V_{CM} = -14.5V$ , $R_S = 50K\Omega$	-150	0.1	nA	1, 2
				+ $V_{CC} = 2V$ , - $V_{CC} = -28V$ , $V_I = 0V$ , $V_{CM} = +13V$ , $R_S = 50K\Omega$	-200	0.1	nA	3
$V_{OSt}$	Collector Output Voltage (Strobe)	+ $V_I = Gnd$ , - $V_I = 15V$ , $I_{St} = -3mA$ , $R_S = 50\Omega$	See <sup>(2)</sup>	14		V	1, 2, 3	
CMRR	Common Mode Rejection	- $28V \leq -V_{CC} \leq -0.5V$ , $R_S = 50\Omega$ , $2V \leq +V_{CC} \leq 29.5V$ , $R_S = 50\Omega$ , - $14.5V \leq V_{CM} \leq 13V$ , $R_S = 50\Omega$		80		dB	1, 2, 3	
$V_{OL}$	Low Level Output Voltage		See <sup>(3)</sup>	+ $V_{CC} = 4.5V$ , - $V_{CC} = Gnd$ , $I_O = 8mA$ , $\pm V_I = 0.5V$ , $V_{ID} = -6mV$	0.4	V	1, 2, 3	
				+ $V_{CC} = 4.5V$ , - $V_{CC} = Gnd$ , $I_O = 8mA$ , $\pm V_I = 3V$ , $V_{ID} = -6mV$	0.4	V	1, 2, 3	
				$I_O = 50mA$ , $\pm V_I = 13V$ , $V_{ID} = -5mV$	1.5	V	1, 2, 3	
				$I_O = 50mA$ , $\pm V_I = -14V$ , $V_{ID} = -5mV$	1.5	V	1, 2, 3	
$I_{CEX}$	Output Leakage Current	+ $V_{CC} = 18V$ , - $V_{CC} = -18V$ , $V_O = 32V$		-1.0	10	nA	1	
				-1.0	500	nA	2	
$I_{IL}$	Input Leakage Current	+ $V_{CC} = 18V$ , - $V_{CC} = -18V$ , + $V_I = +12V$ , - $V_I = -17V$		-5.0	500	nA	1, 2, 3	
				+ $V_{CC} = 18V$ , - $V_{CC} = -18V$ , + $V_I = -17V$ , - $V_I = +12V$	-5.0	500	nA	1, 2, 3
+ $I_{CC}$	Power Supply Current				6.0	mA	1, 2	
					7.0	mA	3	
- $I_{CC}$	Power Supply Current			-5.0		mA	1, 2	
				-6.0		mA	3	
$\Delta V_{IO} / \Delta T$	Temperature Coefficient Input Offset Voltage	$25^\circ C \leq T \leq 125^\circ C$	See <sup>(4)</sup>	-25	25	$\mu V/^\circ C$	2	
		$-55^\circ C \leq T \leq 25^\circ C$	See <sup>(4)</sup>	-25	25	$\mu V/^\circ C$	3	
$\Delta I_{IO} / \Delta T$	Temperature Coefficient Input Offset Current	$25^\circ C \leq T \leq 125^\circ C$	See <sup>(4)</sup>	-100	100	$pA/^\circ C$	2	
		$-55^\circ C \leq T \leq 25^\circ C$	See <sup>(4)</sup>	-200	200	$pA/^\circ C$	3	
$I_{OS}$	Short Circuit Current	$V_O = 5V$ , $t \leq 10mS$ , - $V_I = 0.1V$ , + $V_I = 0V$			200	mA	1	
					150	mA	2	
					250	mA	3	
+ $V_{IO} \text{ adj.}$	Input Offset Voltage (Adjustment)	$V_O = 0V$ , $V_I = 0V$ , $R_S = 50\Omega$		5.0		mV	1	
- $V_{IO} \text{ adj.}$	Input Offset Voltage (Adjustment)	$V_O = 0V$ , $V_I = 0V$ , $R_S = 50\Omega$			-5.0	mV	1	
$\pm A_{VE}$	Voltage Gain (Emitter)	$R_L = 600\Omega$	See <sup>(5)</sup>	10		V/mV	4	
				8.0		V/mV	5, 6	

 (2)  $I_{ST} = -2mA$  at  $-55^\circ C$ 

 (3)  $V_{ID}$  is voltage difference between inputs.

(4) Calculated parameter.

 (5) Datalog reading in  $K=V/mV$ .

### LM111 JAN Electrical Characteristics AC Parameters

The following conditions apply, unless otherwise specified.

AC:  $V_{CC} = \pm 15V$ ,  $V_{CM} = 0$

Symbol	Parameter	Conditions	Notes	Min	Max	Unit	Sub-groups
t <sub>R_LHC</sub>	Response Time (Collector Output)	V <sub>OD</sub> (Overdrive) = -5mV, C <sub>L</sub> = 50pF, V <sub>I</sub> = -100mV			300	nS	7, 8B
					640	nS	8A
t <sub>R_HLC</sub>	Response Time (Collector Output)	V <sub>OD</sub> (Overdrive) = 5mV, C <sub>L</sub> = 50pF, V <sub>I</sub> = 100mV			300	nS	7, 8B
					500	nS	8A

### LM111 JAN Electrical Characteristics DC Drift Parameters

The following conditions apply, unless otherwise specified.

DC:  $V_{CC} = \pm 15V$ ,  $V_{CM} = 0$

Delta calculations performed on JANS devices at group B , subgroup 5.

Symbol	Parameter	Conditions	Notes	Min	Max	Unit	Sub-groups
V <sub>IO</sub>	Input Offset Voltage	V <sub>I</sub> = 0V, R <sub>S</sub> = 50Ω		-0.5	0.5	mV	1
		+V <sub>CC</sub> = 29.5V, -V <sub>CC</sub> = -0.5V, V <sub>I</sub> = 0V, V <sub>CM</sub> = -14.5V, R <sub>S</sub> = 50Ω		-0.5	0.5	mV	1
		+V <sub>CC</sub> = 2V, -V <sub>CC</sub> = -28V, V <sub>I</sub> = 0V, V <sub>CM</sub> = +13V, R <sub>S</sub> = 50Ω		-0.5	0.5	mV	1
±I <sub>B</sub>	Input Bias Current	V <sub>I</sub> = 0V, R <sub>S</sub> = 50KΩ		-12.5	12.5	nA	1
		+V <sub>CC</sub> = 29.5V, -V <sub>CC</sub> = -0.5V, V <sub>I</sub> = 0V, V <sub>CM</sub> = -14.5V, R <sub>S</sub> = 50KΩ		-12.5	12.5	nA	1
		+V <sub>CC</sub> = 2V, -V <sub>CC</sub> = -28V, V <sub>I</sub> = 0V, V <sub>CM</sub> = +13V, R <sub>S</sub> = 50KΩ		-12.5	12.5	nA	1
I <sub>CEX</sub>	Output Leakage Current	+V <sub>CC</sub> = 18V, -V <sub>CC</sub> = -18V, V <sub>O</sub> = 32V		-5.0	5.0	nA	1

LM111 Typical Performance Characteristics

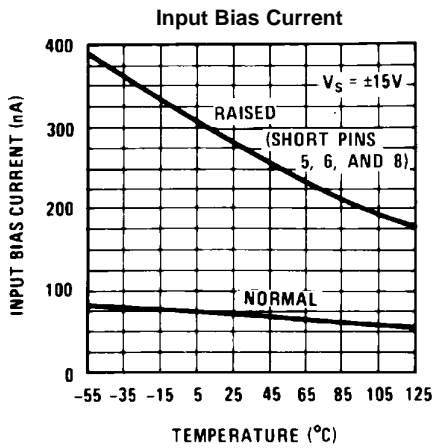

Figure 5.

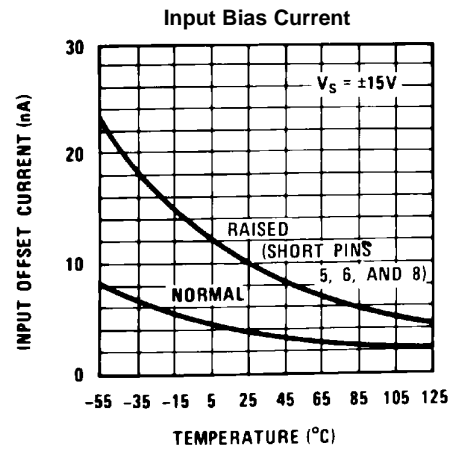

Figure 6.

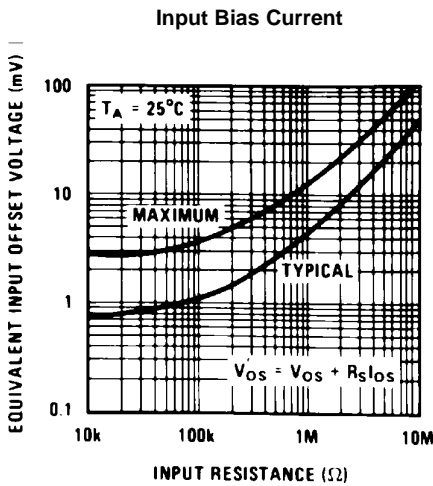

Figure 7.

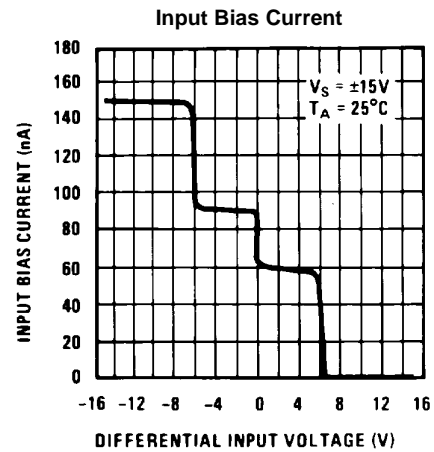

Figure 8.

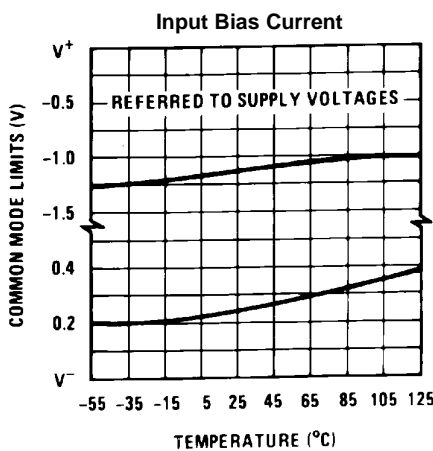

Figure 9.

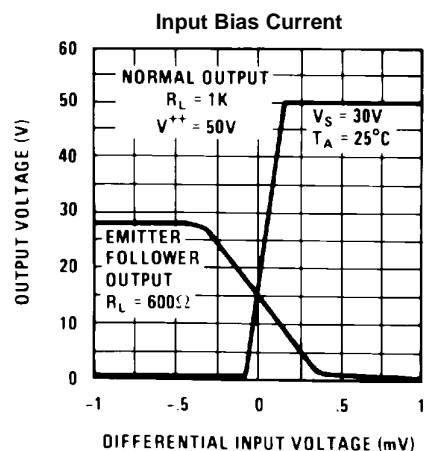

Figure 10.

**LM111 Typical Performance Characteristics (continued)**  
**Input Bias Current**  
**Input Overdrives**

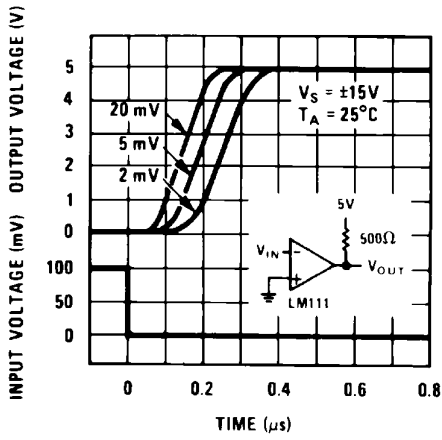

Figure 11.

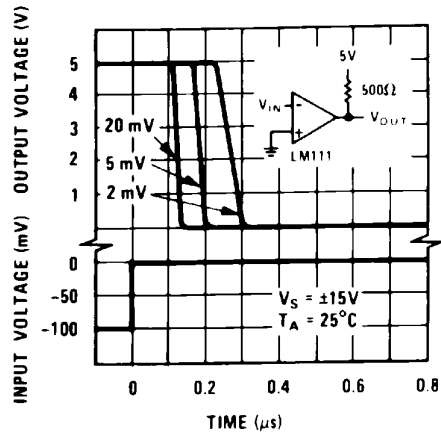

Figure 12.

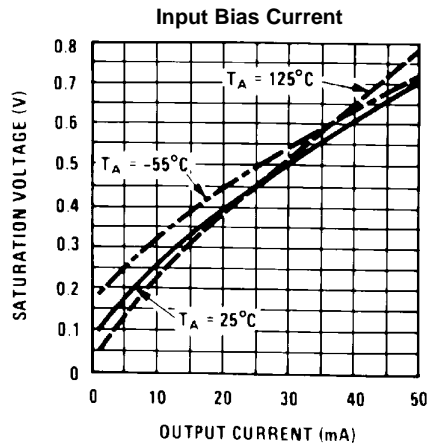

Figure 13.

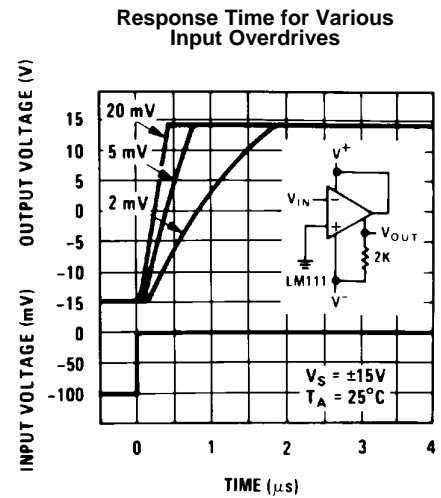

Figure 14.

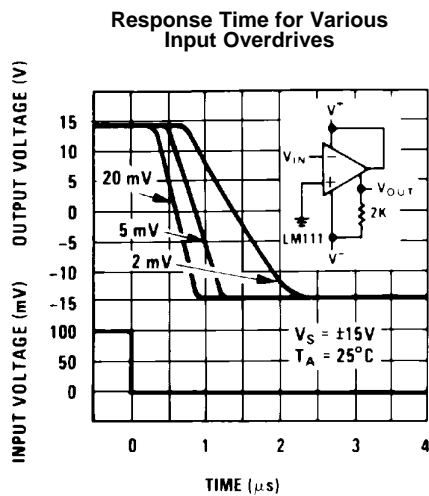

Figure 15.

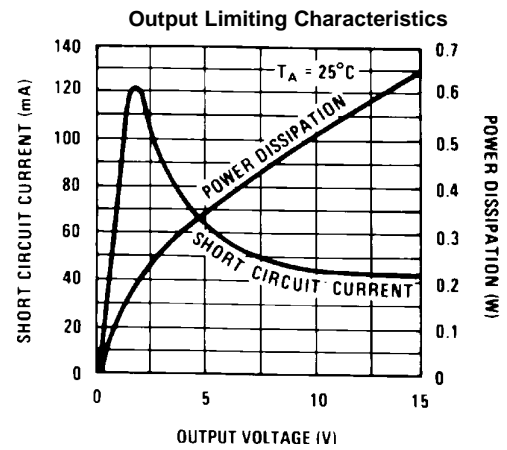

Figure 16.

LM111 Typical Performance Characteristics (continued)

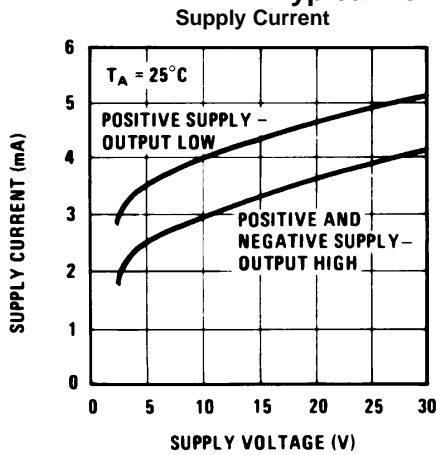

Figure 17.

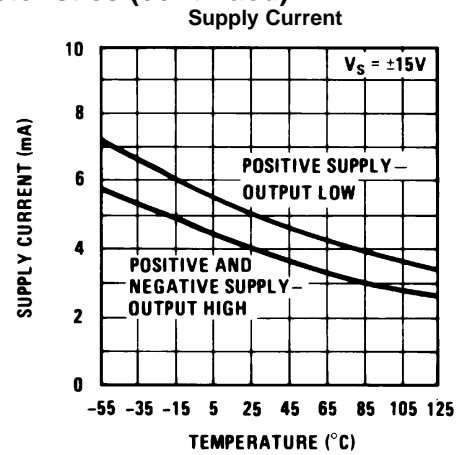

Figure 18.

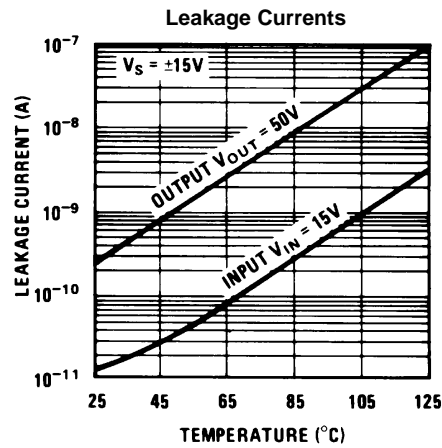

Figure 19.

## APPLICATION HINTS

### CIRCUIT TECHNIQUES FOR AVOIDING OSCILLATIONS IN COMPARATOR APPLICATIONS

When a high-speed comparator such as the LM111 is used with fast input signals and low source impedances, the output response will normally be fast and stable, assuming that the power supplies have been bypassed (with 0.1  $\mu\text{F}$  disc capacitors), and that the output signal is routed well away from the inputs (pins 2 and 3) and also away from pins 5 and 6.

However, when the input signal is a voltage ramp or a slow sine wave, or if the signal source impedance is high (1  $\text{k}\Omega$  to 100  $\text{k}\Omega$ ), the comparator may burst into oscillation near the crossing-point. This is due to the high gain and wide bandwidth of comparators such as the LM111. To avoid oscillation or instability in such a usage, several precautions are recommended, as shown in [Figure 20](#) below.

1. The trim pins (pins 5 and 6) act as unwanted auxiliary inputs. If these pins are not connected to a trim-pot, they should be shorted together. If they are connected to a trim-pot, a 0.01  $\mu\text{F}$  capacitor C1 between pins 5 and 6 will minimize the susceptibility to AC coupling. A smaller capacitor is used if pin 5 is used for positive feedback as in [Figure 20](#).
2. Certain sources will produce a cleaner comparator output waveform if a 100 pF to 1000 pF capacitor C2 is connected directly across the input pins.
3. When the signal source is applied through a resistive network,  $R_S$ , it is usually advantageous to choose an  $R_S'$  of substantially the same value, both for DC and for dynamic (AC) considerations. Carbon, tin-oxide, and metal-film resistors have all been used successfully in comparator input circuitry. Inductive wire wound resistors are not suitable.
4. When comparator circuits use input resistors (e.g. summing resistors), their value and placement are particularly important. In all cases the body of the resistor should be close to the device or socket. In other words there should be very little lead length or printed-circuit foil run between comparator and resistor to radiate or pick up signals. The same applies to capacitors, pots, etc. For example, if  $R_S=10 \text{ k}\Omega$ , as little as 5 inches of lead between the resistors and the input pins can result in oscillations that are very hard to damp. Twisting these input leads tightly is the only (second best) alternative to placing resistors close to the comparator.
5. Since feedback to almost any pin of a comparator can result in oscillation, the printed-circuit layout should be engineered thoughtfully. Preferably there should be a ground plane under the LM111 circuitry, for example, one side of a double-layer circuit card. Ground foil (or, positive supply or negative supply foil) should extend between the output and the inputs, to act as a guard. The foil connections for the inputs should be as small and compact as possible, and should be essentially surrounded by ground foil on all sides, to guard against capacitive coupling from any high-level signals (such as the output). If pins 5 and 6 are not used, they should be shorted together. If they are connected to a trim-pot, the trim-pot should be located, at most, a few inches away from the LM111, and the 0.01  $\mu\text{F}$  capacitor should be installed. If this capacitor cannot be used, a shielding printed-circuit foil may be advisable between pins 6 and 7. The power supply bypass capacitors should be located within a couple inches of the LM111. (Some other comparators require the power-supply bypass to be located immediately adjacent to the comparator.)
6. It is a standard procedure to use hysteresis (positive feedback) around a comparator, to prevent oscillation, and to avoid excessive noise on the output because the comparator is a good amplifier for its own noise. In the circuit of [Figure 21](#), the feedback from the output to the positive input will cause about 3 mV of hysteresis. However, if  $R_S$  is larger than 100 $\Omega$ , such as 50  $\text{k}\Omega$ , it would not be reasonable to simply increase the value of the positive feedback resistor above 510  $\text{k}\Omega$ . The circuit of [Figure 22](#) could be used, but it is rather awkward. See the notes in paragraph 7 below.
7. When both inputs of the LM111 are connected to active signals, or if a high-impedance signal is driving the positive input of the LM111 so that positive feedback would be disruptive, the circuit of [Figure 20](#) is ideal. The positive feedback is to pin 5 (one of the offset adjustment pins). It is sufficient to cause 1 to 2 mV hysteresis and sharp transitions with input triangle waves from a few Hz to hundreds of kHz. The positive-feedback signal across the 82 $\Omega$  resistor swings 240 mV below the positive supply. This signal is centered around the nominal voltage at pin 5, so this feedback does not add to the  $V_{OS}$  of the comparator. As much as 8 mV of  $V_{OS}$  can be trimmed out, using the 5  $\text{k}\Omega$  pot and 3  $\text{k}\Omega$  resistor as shown.
8. These application notes apply specifically to the LM111 and LF111 families of comparators, and are applicable to all high-speed comparators in general, (with the exception that not all comparators have trim pins).

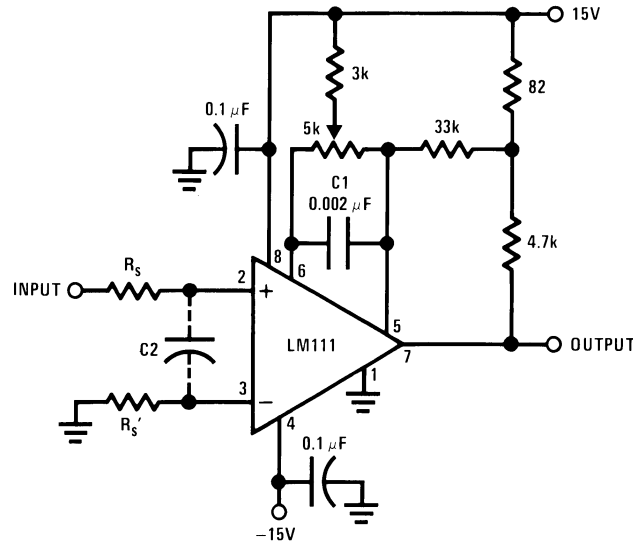

Pin connections shown are for LM111H in the LMC0008C hermetic package

**Figure 20. Improved Positive Feedback**

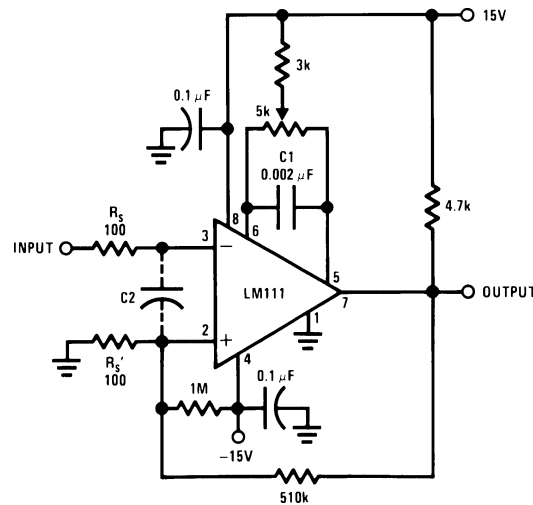

Pin connections shown are for LM111H in the LMC0008C hermetic package

**Figure 21. Conventional Positive Feedback**

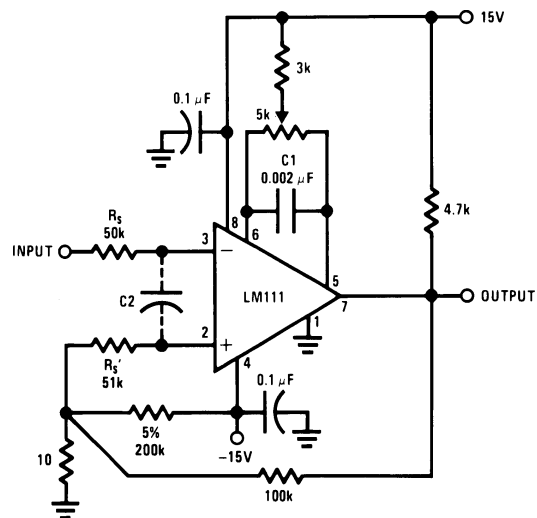

Figure 22. Positive Feedback with High Source Resistance

## Typical Applications

Pin connections shown on schematic diagram and typical applications are for LMC0008C metal can package.

Offset Balancing

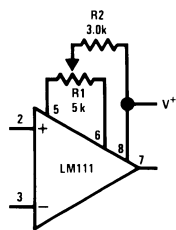
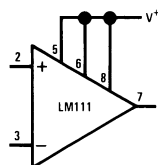

Figure 23.

Increasing Input Stage Current



Note: Increases typical common mode slew from 7.0V/ $\mu$ s to 18V/ $\mu$ s.

Figure 25.

Digital Transmission Isolator

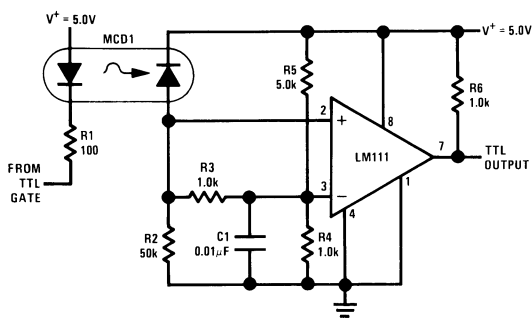
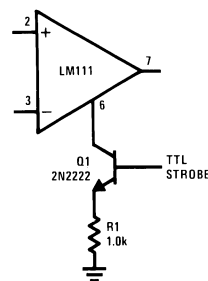

Figure 27.

Strobing



Note: Do Not Ground Strobe Pin. Output is turned off when current is pulled from Strobe Pin.

Figure 24.

Detector for Magnetic Transducer

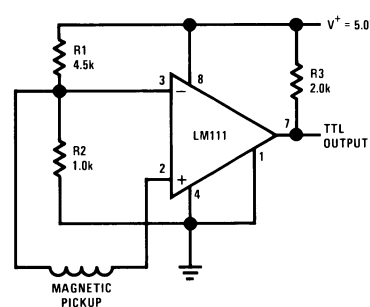
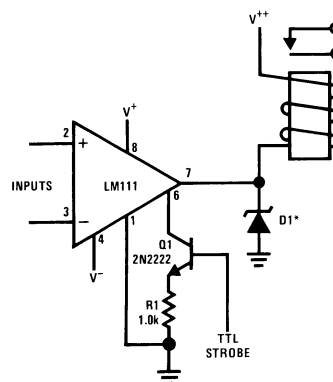

Figure 26.

Relay Driver with Strobe



\*Absorbs inductive kickback of relay and protects IC from severe voltage transients on V<sup>++</sup> line.

Note: Do Not Ground Strobe Pin.

Figure 28.

**Strobing off Both Input and Output Stages**

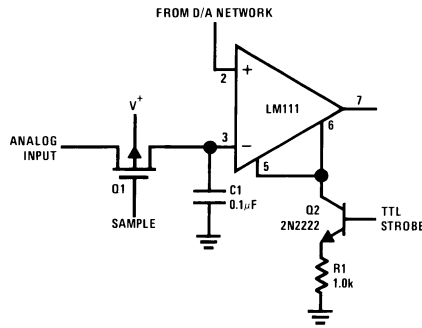

Note: Typical input current is 50 pA with inputs strobed off. **Figure 29.**

**Positive Peak Detector**

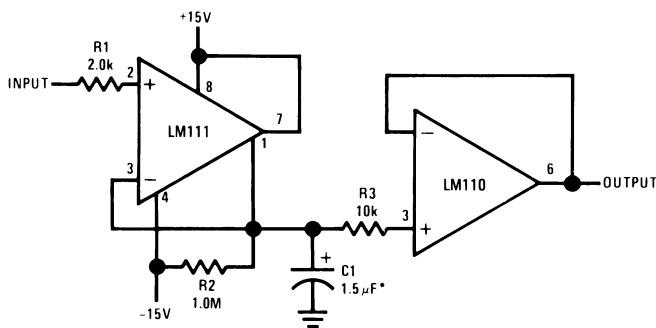

\*Solid tantalum

**Figure 30.**

**Zero Crossing Detector Driving MOS Logic**

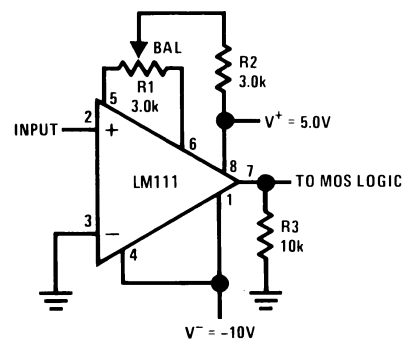
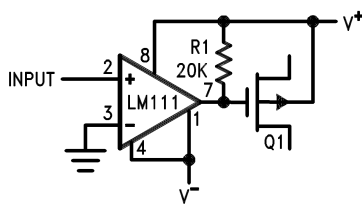

**Figure 31.**

**Typical Applications**

(Pin numbers refer to LMC0008C package)

**Zero Crossing Detector Driving MOS Switch**



**Figure 32.**

**100 kHz Free Running Multivibrator**

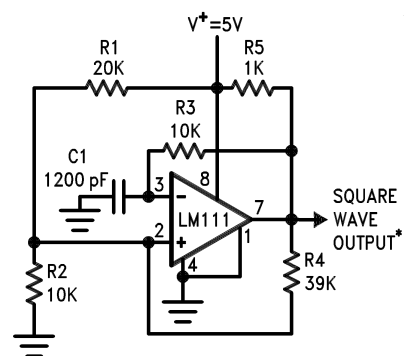

\*TTL or DTL fanout of two

**Figure 33.**

10 Hz to 10 kHz Voltage Controlled Oscillator

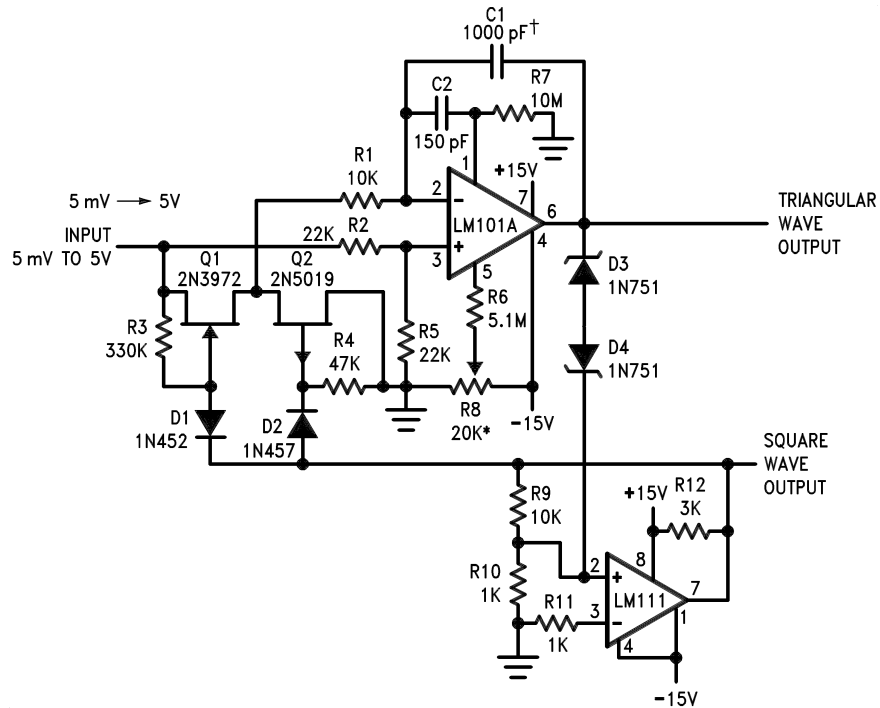

\*Adjust for symmetrical square wave time when  $V_{IN} = 5\text{ mV}$   
 †Minimum capacitance 20 pF Maximum frequency 50 kHz

Figure 34.

Driving Ground-Referred Load

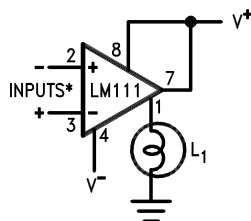

\*Input polarity is reversed when using pin 1 as output.

Figure 35.

Using Clamp Diodes to Improve Response

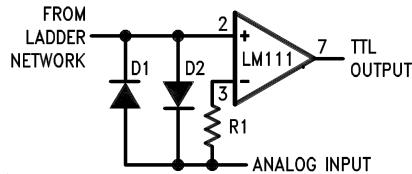
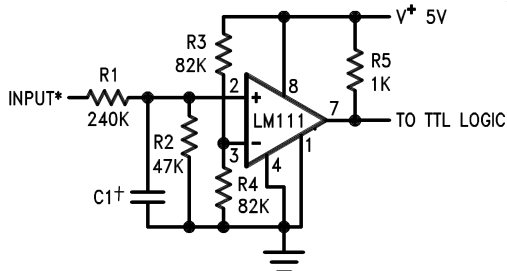

Figure 36.

TTL Interface with High Level Logic



\*Values shown are for a 0 to 30V logic swing and a 15V threshold.  
 †May be added to control speed and reduce susceptibility to noise spikes.

Figure 37.

**Crystal Oscillator**

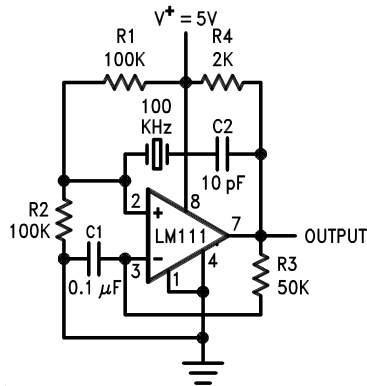

**Figure 38.**

**Comparator and Solenoid Driver**

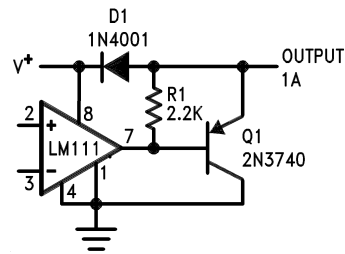

**Figure 39.**

**Precision Squarer**

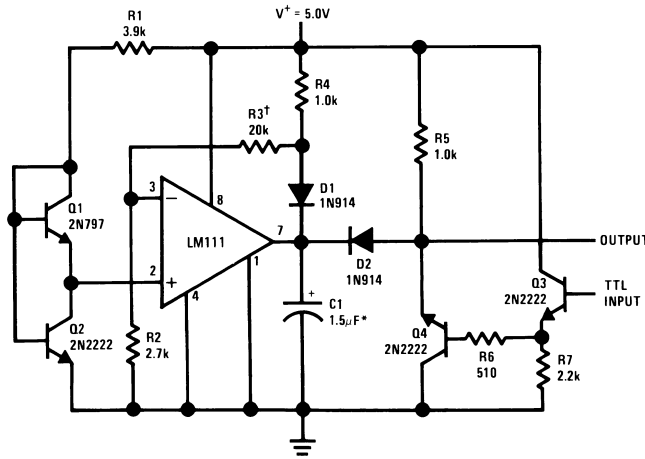

**Figure 40.**

\*Solid tantalum  
†Adjust to set clamp level

**Low Voltage Adjustable Reference Supply**

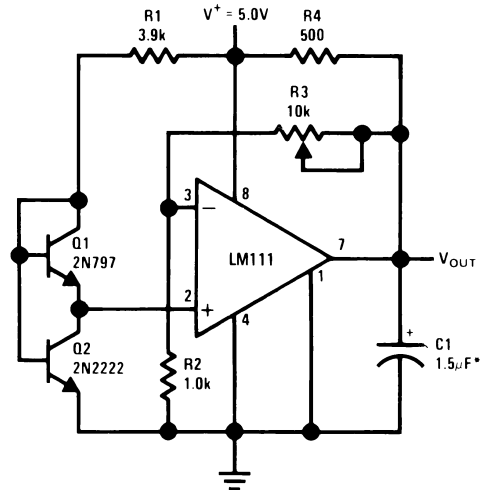

**Figure 41.**

\*Solid tantalum

**Positive Peak Detector**

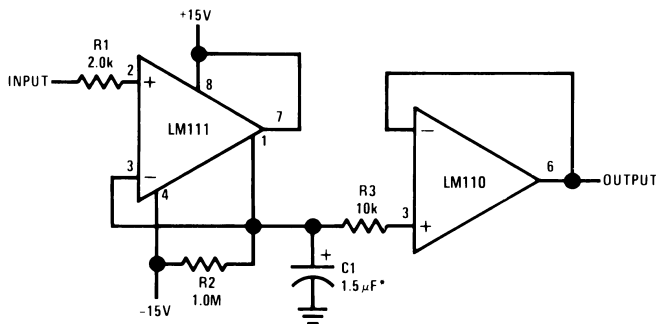

**Figure 42.**

\*Solid tantalum

**Zero Crossing Detector Driving MOS Logic**

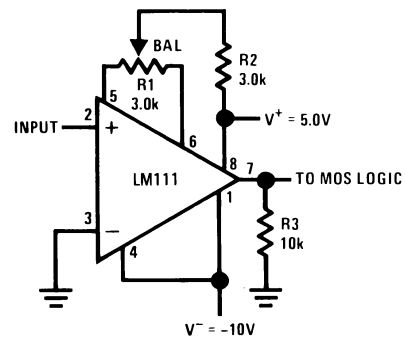

**Figure 43.**

Negative Peak Detector

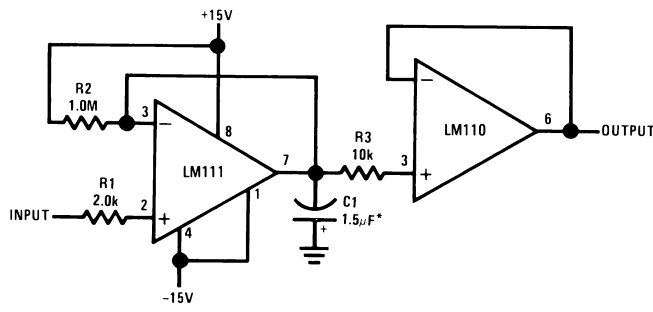

\*Solid tantalum

Figure 44.

Precision Photodiode Comparator

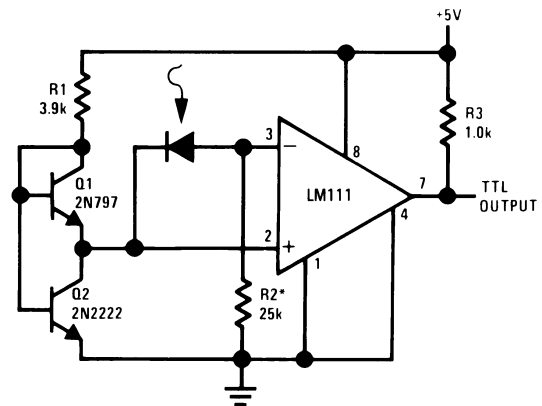

\*R2 sets the comparison level. At comparison, the photodiode has less than 5 mV across it, decreasing leakages by an order of magnitude.

Figure 45.

Switching Power Amplifier

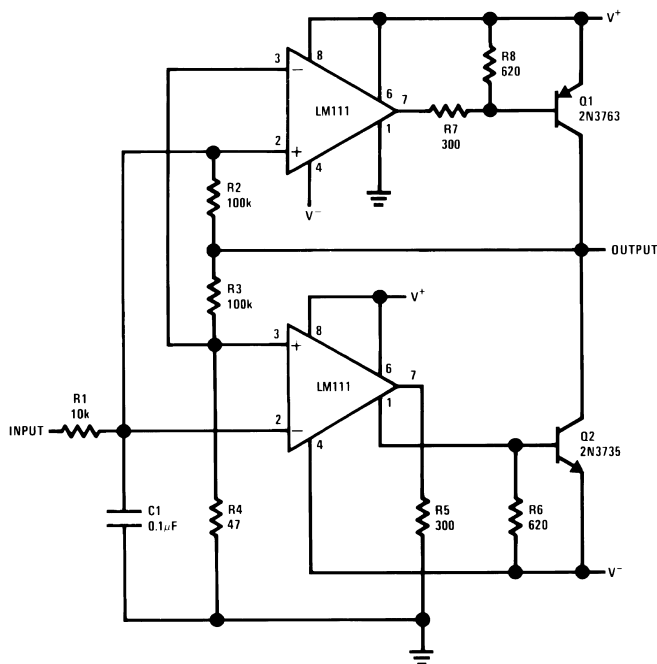

Figure 46.

Switching Power Amplifier

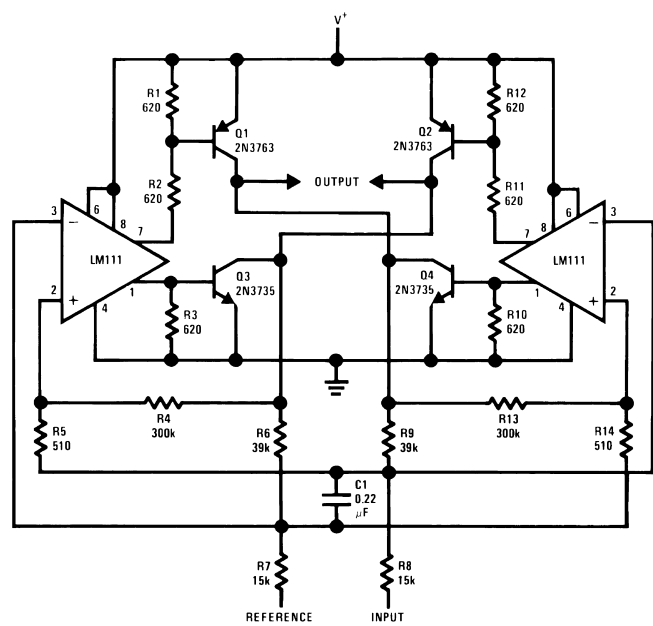

Figure 47.

**REVISION HISTORY SECTION**

Released	Revision	Section	Originator	Changes
05/09/05	A	New Release, Corporate format	L. Lytle	1 MDS data sheets converted into one Corp. data sheet format. MJLM111–X Rev 0D3 will be archived.
03/26/2013	B	All Sections		Changed layout of National Data Sheet to TI format

**PACKAGING INFORMATION**

Orderable Device	Status (1)	Package Type	Package Drawing	Pins	Package Qty	Eco Plan (2)	Lead/Ball Finish	MSL Peak Temp (3)	Op Temp (°C)	Top-Side Markings (4)	Samples
JL111BGA	ACTIVE	TO-99	LMC	8	20	TBD	Call TI	Call TI	-55 to 125	JL111BGA JM38510/10304BGA Q ACO JM38510/10304BGA Q >T	<a href="#">Samples</a>
JM38510/10304BGA	ACTIVE	TO-99	LMC	8	20	TBD	Call TI	Call TI	-55 to 125	JL111BGA JM38510/10304BGA Q ACO JM38510/10304BGA Q >T	<a href="#">Samples</a>
M38510/10304BGA	ACTIVE	TO-99	LMC	8	20	TBD	Call TI	Call TI	-55 to 125	JL111BGA JM38510/10304BGA Q ACO JM38510/10304BGA Q >T	<a href="#">Samples</a>

(1) The marketing status values are defined as follows:

**ACTIVE:** Product device recommended for new designs.

**LIFEBUY:** TI has announced that the device will be discontinued, and a lifetime-buy period is in effect.

**NRND:** Not recommended for new designs. Device is in production to support existing customers, but TI does not recommend using this part in a new design.

**PREVIEW:** Device has been announced but is not in production. Samples may or may not be available.

**OBSOLETE:** TI has discontinued the production of the device.

(2) Eco Plan - The planned eco-friendly classification: Pb-Free (RoHS), Pb-Free (RoHS Exempt), or Green (RoHS & no Sb/Br) - please check <http://www.ti.com/productcontent> for the latest availability information and additional product content details.

**TBD:** The Pb-Free/Green conversion plan has not been defined.

**Pb-Free (RoHS):** TI's terms "Lead-Free" or "Pb-Free" mean semiconductor products that are compatible with the current RoHS requirements for all 6 substances, including the requirement that lead not exceed 0.1% by weight in homogeneous materials. Where designed to be soldered at high temperatures, TI Pb-Free products are suitable for use in specified lead-free processes.

**Pb-Free (RoHS Exempt):** This component has a RoHS exemption for either 1) lead-based flip-chip solder bumps used between the die and package, or 2) lead-based die adhesive used between the die and leadframe. The component is otherwise considered Pb-Free (RoHS compatible) as defined above.

**Green (RoHS & no Sb/Br):** TI defines "Green" to mean Pb-Free (RoHS compatible), and free of Bromine (Br) and Antimony (Sb) based flame retardants (Br or Sb do not exceed 0.1% by weight in homogeneous material)

(3) MSL, Peak Temp. -- The Moisture Sensitivity Level rating according to the JEDEC industry standard classifications, and peak solder temperature.

(4) Multiple Top-Side Markings will be inside parentheses. Only one Top-Side Marking contained in parentheses and separated by a "~" will appear on a device. If a line is indented then it is a continuation of the previous line and the two combined represent the entire Top-Side Marking for that device.

**Important Information and Disclaimer:** The information provided on this page represents TI's knowledge and belief as of the date that it is provided. TI bases its knowledge and belief on information provided by third parties, and makes no representation or warranty as to the accuracy of such information. Efforts are underway to better integrate information from third parties. TI has taken and continues to take reasonable steps to provide representative and accurate information but may not have conducted destructive testing or chemical analysis on incoming materials and chemicals. TI and TI suppliers consider certain information to be proprietary, and thus CAS numbers and other limited information may not be available for release.

In no event shall TI's liability arising out of such information exceed the total purchase price of the TI part(s) at issue in this document sold by TI to Customer on an annual basis.

**OTHER QUALIFIED VERSIONS OF LM111JAN, LM111JAN-SP :**

- Military: [LM111JAN](#)
- Space: [LM111JAN-SP](#)

NOTE: Qualified Version Definitions:

- Military - QML certified for Military and Defense Applications
- Space - Radiation tolerant, ceramic packaging and qualified for use in Space-based application



## IMPORTANT NOTICE

Texas Instruments Incorporated and its subsidiaries (TI) reserve the right to make corrections, enhancements, improvements and other changes to its semiconductor products and services per JESD46, latest issue, and to discontinue any product or service per JESD48, latest issue. Buyers should obtain the latest relevant information before placing orders and should verify that such information is current and complete. All semiconductor products (also referred to herein as "components") are sold subject to TI's terms and conditions of sale supplied at the time of order acknowledgment.

TI warrants performance of its components to the specifications applicable at the time of sale, in accordance with the warranty in TI's terms and conditions of sale of semiconductor products. Testing and other quality control techniques are used to the extent TI deems necessary to support this warranty. Except where mandated by applicable law, testing of all parameters of each component is not necessarily performed.

TI assumes no liability for applications assistance or the design of Buyers' products. Buyers are responsible for their products and applications using TI components. To minimize the risks associated with Buyers' products and applications, Buyers should provide adequate design and operating safeguards.

TI does not warrant or represent that any license, either express or implied, is granted under any patent right, copyright, mask work right, or other intellectual property right relating to any combination, machine, or process in which TI components or services are used. Information published by TI regarding third-party products or services does not constitute a license to use such products or services or a warranty or endorsement thereof. Use of such information may require a license from a third party under the patents or other intellectual property of the third party, or a license from TI under the patents or other intellectual property of TI.

Reproduction of significant portions of TI information in TI data books or data sheets is permissible only if reproduction is without alteration and is accompanied by all associated warranties, conditions, limitations, and notices. TI is not responsible or liable for such altered documentation. Information of third parties may be subject to additional restrictions.

Resale of TI components or services with statements different from or beyond the parameters stated by TI for that component or service voids all express and any implied warranties for the associated TI component or service and is an unfair and deceptive business practice. TI is not responsible or liable for any such statements.

Buyer acknowledges and agrees that it is solely responsible for compliance with all legal, regulatory and safety-related requirements concerning its products, and any use of TI components in its applications, notwithstanding any applications-related information or support that may be provided by TI. Buyer represents and agrees that it has all the necessary expertise to create and implement safeguards which anticipate dangerous consequences of failures, monitor failures and their consequences, lessen the likelihood of failures that might cause harm and take appropriate remedial actions. Buyer will fully indemnify TI and its representatives against any damages arising out of the use of any TI components in safety-critical applications.

In some cases, TI components may be promoted specifically to facilitate safety-related applications. With such components, TI's goal is to help enable customers to design and create their own end-product solutions that meet applicable functional safety standards and requirements. Nonetheless, such components are subject to these terms.

No TI components are authorized for use in FDA Class III (or similar life-critical medical equipment) unless authorized officers of the parties have executed a special agreement specifically governing such use.

Only those TI components which TI has specifically designated as military grade or "enhanced plastic" are designed and intended for use in military/aerospace applications or environments. Buyer acknowledges and agrees that any military or aerospace use of TI components which have **not** been so designated is solely at the Buyer's risk, and that Buyer is solely responsible for compliance with all legal and regulatory requirements in connection with such use.

TI has specifically designated certain components as meeting ISO/TS16949 requirements, mainly for automotive use. In any case of use of non-designated products, TI will not be responsible for any failure to meet ISO/TS16949.

### Products

Audio	<a href="http://www.ti.com/audio">www.ti.com/audio</a>
Amplifiers	<a href="http://amplifier.ti.com">amplifier.ti.com</a>
Data Converters	<a href="http://dataconverter.ti.com">dataconverter.ti.com</a>
DLP® Products	<a href="http://www.dlp.com">www.dlp.com</a>
DSP	<a href="http://dsp.ti.com">dsp.ti.com</a>
Clocks and Timers	<a href="http://www.ti.com/clocks">www.ti.com/clocks</a>
Interface	<a href="http://interface.ti.com">interface.ti.com</a>
Logic	<a href="http://logic.ti.com">logic.ti.com</a>
Power Mgmt	<a href="http://power.ti.com">power.ti.com</a>
Microcontrollers	<a href="http://microcontroller.ti.com">microcontroller.ti.com</a>
RFID	<a href="http://www.ti-rfid.com">www.ti-rfid.com</a>
OMAP Applications Processors	<a href="http://www.ti.com/omap">www.ti.com/omap</a>
Wireless Connectivity	<a href="http://www.ti.com/wirelessconnectivity">www.ti.com/wirelessconnectivity</a>

### Applications

Automotive and Transportation	<a href="http://www.ti.com/automotive">www.ti.com/automotive</a>
Communications and Telecom	<a href="http://www.ti.com/communications">www.ti.com/communications</a>
Computers and Peripherals	<a href="http://www.ti.com/computers">www.ti.com/computers</a>
Consumer Electronics	<a href="http://www.ti.com/consumer-apps">www.ti.com/consumer-apps</a>
Energy and Lighting	<a href="http://www.ti.com/energy">www.ti.com/energy</a>
Industrial	<a href="http://www.ti.com/industrial">www.ti.com/industrial</a>
Medical	<a href="http://www.ti.com/medical">www.ti.com/medical</a>
Security	<a href="http://www.ti.com/security">www.ti.com/security</a>
Space, Avionics and Defense	<a href="http://www.ti.com/space-avionics-defense">www.ti.com/space-avionics-defense</a>
Video and Imaging	<a href="http://www.ti.com/video">www.ti.com/video</a>

### TI E2E Community

[e2e.ti.com](http://e2e.ti.com)