

## LM118JAN Operational Amplifier

Check for Samples: [LM118JAN](#)

### FEATURES

- 15 MHz Small Signal Bandwidth
- Ensured 50V/μs Slew Rate
- Maximum Bias Current of 250 nA
- Operates from Supplies of ±5V to ±20V
- Internal Frequency Compensation
- Input and Output Overload Protected
- Pin Compatible with General Purpose Op Amps

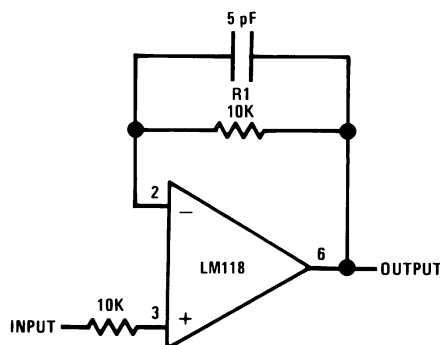
### DESCRIPTION

The LM118 is a precision high speed operational amplifier designed for applications requiring wide bandwidth and high slew rate. It features a factor of ten increase in speed over general purpose devices without sacrificing DC performance.

The LM118 has internal unity gain frequency compensation. This considerably simplifies its application since no external components are necessary for operation. However, unlike most internally compensated amplifiers, external frequency compensation may be added for optimum performance. For inverting applications, feed forward compensation will boost the slew rate to over 150V/μs and almost double the bandwidth. Overcompensation can be used with the amplifier for greater stability when maximum bandwidth is not needed. Further, a single capacitor can be added to reduce the 0.1% settling time to under 1 μs.

The high speed and fast settling time of this op amp makes it useful in A/D converters, oscillators, active filters, sample and hold circuits, or general purpose amplifiers. This device is easy to apply and offers an order of magnitude better AC performance than industry standards such as the LM709.

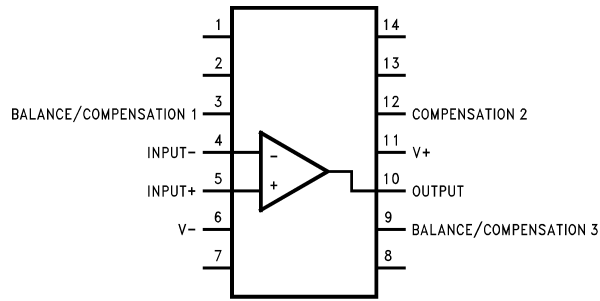
### Fast Voltage Follower


Do not hard-wire as voltage follower ( $R1 \geq 5 \text{ k}\Omega$ )

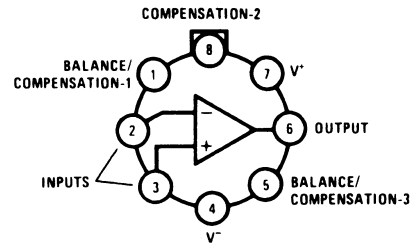

Please be aware that an important notice concerning availability, standard warranty, and use in critical applications of Texas Instruments semiconductor products and disclaimers thereto appears at the end of this data sheet.

All trademarks are the property of their respective owners.

Connection Diagram

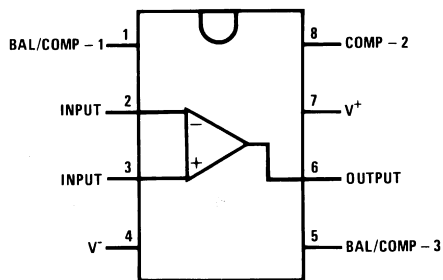


**Figure 1. CDIP Package Top View**  
See Package Number J0014A

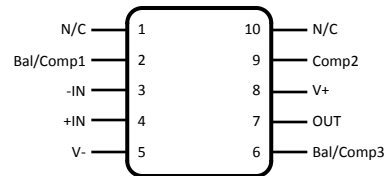


Pin connections shown on schematic diagram and typical applications are for TO-5 package.

**Figure 2. TO Package Top View**  
See Package Number LMC0008C

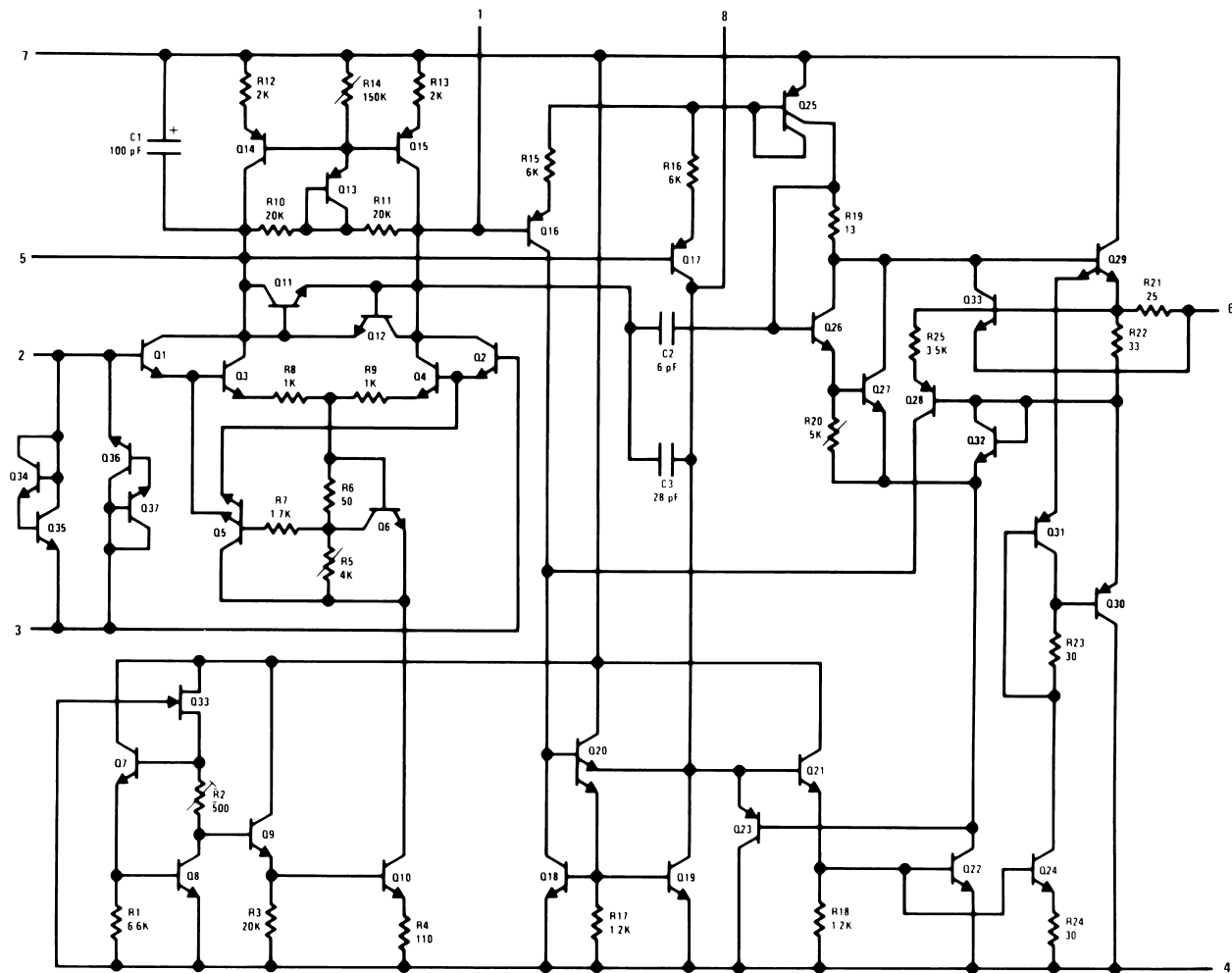


**Figure 3. CDIP Package Top View**  
See Package Number NAB0008A



**Figure 4. CLGA Package Top View**  
See Package Number NAD0010A

**Schematic Diagram**



These devices have limited built-in ESD protection. The leads should be shorted together or the device placed in conductive foam during storage or handling to prevent electrostatic damage to the MOS gates.

**Absolute Maximum Ratings<sup>(1)</sup>**

Supply Voltage		±20V	
Power Dissipation <sup>(2)</sup>	8 LD TO	750mW	
	8LD CDIP	1000mW	
	14LD CDIP	1250mW	
	10LD CLGA	600mW	
Differential Input Current <sup>(3)</sup>		±10 mA	
Input Voltage <sup>(4)</sup>		±15V	
Output Short-Circuit Duration		Continuous	
Operating Temperature Range		-55°C ≤ T <sub>A</sub> ≤ +125°C	
Thermal Resistance	θ <sub>JA</sub>	8 LD TO (Still Air @ 0.5W)	160°C/W
		8 LD TO (500LF / Min Air flow @ 0.5W)	86°C/W
		8LD CDIP (Still Air @ 0.5W)	120°C/W
		8LD CDIP (500LF / Min Air flow @ 0.5W)	66°C/W
		14LD CDIP (Still Air @ 0.5W)	87°C/W
		14LD CDIP (500LF / Min Air flow @ 0.5W)	51°C/W
		10LD CLGA (Still Air @ 0.5W)	198°C/W
		10LD CLGA (500LF / Min Air flow @ 0.5W)	124°C/W
	θ <sub>JC</sub>	8 LD TO	48°C/W
		8LD CDIP	17°C/W
		14LD CDIP	17°C/W
		10LD CLGA	22°C/W
Storage Temperature Range		-65°C ≤ T <sub>A</sub> ≤ +150°C	
Lead Temperature (Soldering, 10 seconds)		300°C	
ESD Tolerance <sup>(5)</sup>		2000V	

- (1) Absolute Maximum Ratings indicate limits beyond which damage to the device may occur. Operating Ratings indicate conditions for which the device is functional, but do not ensure specific performance limits. For ensured specifications and test conditions, see the Electrical Characteristics. The ensured specifications apply only for the test conditions listed. Some performance characteristics may degrade when the device is not operated under the listed test conditions.
- (2) The maximum power dissipation must be derated at elevated temperatures and is dictated by T<sub>Jmax</sub> (maximum junction temperature), θ<sub>JA</sub> (package junction to ambient thermal resistance), and T<sub>A</sub> (ambient temperature). The maximum allowable power dissipation at any temperature is P<sub>Dmax</sub> = (T<sub>Jmax</sub> - T<sub>A</sub>)/θ<sub>JA</sub> or the number given in the Absolute Maximum Ratings, whichever is lower.
- (3) The inputs are shunted with back-to-back diodes for over voltage protection. Therefore, excessive current will flow if a differential input voltage in excess of 1V is applied between the inputs unless some limiting resistance is used.
- (4) For supply voltages less than ±15V, the absolute maximum input voltage is equal to the supply voltage.
- (5) Human body model, 1.5 kΩ in series with 100 pF.

## Quality Conformance Inspection

Mil-Std-883, Method 5005; Group A

Subgroup	Description	Temp°C
1	Static tests at	25
2	Static tests at	125
3	Static tests at	-55
4	Dynamic tests at	25
5	Dynamic tests at	125
6	Dynamic tests at	-55
7	Functional tests at	25
8A	Functional tests at	125
8B	Functional tests at	-55
9	Switching tests at	25
10	Switching tests at	125
11	Switching tests at	-55
12	Settling time at	25
13	Settling time at	125
14	Settling time at	-55

## LM118JAN Electrical Characteristics DC Parameters

The following conditions apply to all the following parameters, unless otherwise specified.

 DC:  $V_{CC} = \pm 20V$ 

Symbol	Parameter	Conditions	Notes	Min	Max	Unit	Sub-groups
$V_{IO}$	Input Offset Voltage	$+V_{CC} = 35V, -V_{CC} = -5V, V_{CM} = -15V$		-4.0	4.0	mV	1
				-6.0	6.0	mV	2, 3
		$+V_{CC} = 5V, -V_{CC} = -35V, V_{CM} = 15V$		-4.0	4.0	mV	1
				-6.0	6.0	mV	2, 3
		$V_{CM} = 0V$		-4.0	4.0	mV	1
				-6.0	6.0	mV	2, 3
$I_{IO}$	Input Offset Current	$+V_{CC} = 35V, -V_{CC} = -5V, V_{CM} = -15V, R_S = 100K\Omega$	See <sup>(1)</sup>	-40	40	nA	1
			See <sup>(1)</sup>	-80	80	nA	2, 3
		$+V_{CC} = 5V, -V_{CC} = -35V, V_{CM} = 15V, R_S = 100K\Omega$	See <sup>(1)</sup>	-40	40	nA	1
			See <sup>(1)</sup>	-80	80	nA	2, 3
		$V_{CM} = 0V, R_S = 100K\Omega$	See <sup>(1)</sup>	-40	40	nA	1
			See <sup>(1)</sup>	-80	80	nA	2, 3
$\pm I_{IB}$	Input Bias Current	$+V_{CC} = 35V, -V_{CC} = -5V, V_{CM} = -15V, R_S = 100K\Omega$	See <sup>(1)</sup>	1.0	250	nA	1, 2
			See <sup>(1)</sup>	1.0	400	nA	3
		$+V_{CC} = 5V, -V_{CC} = -35V, V_{CM} = 15V, R_S = 100K\Omega$	See <sup>(1)</sup>	1.0	250	nA	1, 2
			See <sup>(1)</sup>	1.0	400	nA	3
		$V_{CM} = 0V, R_S = 100K\Omega$	See <sup>(1)</sup>	1.0	250	nA	1, 2
			See <sup>(1)</sup>	1.0	400	nA	3
$+V_{CC} = 5V, -V_{CC} = -5V, V_{CM} = 0V, R_S = 100K\Omega$	See <sup>(1)</sup>	1.0	250	nA	1, 2		
	See <sup>(1)</sup>	1.0	400	nA	3		

 (1) Slash Sheet:  $R_S = 20K\Omega$ , tested with  $R_S = 100K\Omega$  for better resolution.

## LM118JAN Electrical Characteristics DC Parameters (continued)

The following conditions apply to all the following parameters, unless otherwise specified.

DC:  $V_{CC} = \pm 20V$

Symbol	Parameter	Conditions	Notes	Min	Max	Unit	Sub-groups
+PSRR	Power Supply Rejection Ratio	$+V_{CC} = 10V, -V_{CC} = -20V$		-100	100	$\mu V/V$	1
				-150	150	$\mu V/V$	2, 3
-PSRR	Power Supply Rejection Ratio	$+V_{CC} = 20V, -V_{CC} = -10V$		-100	100	$\mu V/V$	1
				-150	150	$\mu V/V$	2, 3
CMRR	Common Mode Rejection Ratio	$V_{CM} = \pm 15V,$ $V_{CC} = \pm 35V$ to $\pm 5V$		80		dB	1, 2, 3
+ $V_{IO}$ adj.	Offset Null			7.0		mV	1, 2, 3
- $V_{IO}$ adj.	Offset Null				-7.0	mV	1, 2, 3
Delta $V_{IO}$ / Delta T	Temperature Coefficient of Input Offset Voltage	$25^\circ C \leq T_A \leq 125^\circ C$	See <sup>(2)</sup>	-50	50	$\mu V/^\circ C$	2
		$-55^\circ C \leq T_A \leq 25^\circ C$	See <sup>(2)</sup>	-50	50	$\mu V/^\circ C$	3
Delta $I_{IO}$ / Delta T	Temperature Coefficient of Input Offset Current	$25^\circ C \leq T_A \leq 125^\circ C$	See <sup>(2)</sup>	-	1000	$pA/^\circ C$	2
		$-55^\circ C \leq T_A \leq 25^\circ C$	See <sup>(2)</sup>	-	1000	$pA/^\circ C$	3
+ $I_{OS}$	Short Circuit Current	$+V_{CC} = 15V, -V_{CC} = -15V,$ $t \leq 25mS, V_{CM} = -15V$		-65		mA	1, 2, 3
- $I_{OS}$	Short Circuit Current	$+V_{CC} = 15V, -V_{CC} = -15V,$ $t \leq 25mS, V_{CM} = 15V$			65	mA	1, 2
					80	mA	3
$I_{CC}$	Power Supply Current	$+V_{CC} = 15V, -V_{CC} = -15V$			8.0	mA	1
					7.0	mA	2
					9.0	mA	3
+ $V_{Opp}$	Output Voltage Swing	$R_L = 10K\Omega, V_{CM} = -20V$		17		V	4, 5, 6
		$R_L = 2K\Omega, V_{CM} = -20V$		16		V	4, 5, 6
- $V_{Opp}$	Output Voltage Swing	$R_L = 10K\Omega, V_{CM} = 20V$			-17	V	4, 5, 6
		$R_L = 2K\Omega, V_{CM} = 20V$			-16	V	4, 5, 6
+ $A_{VS}$	Open Loop Voltage Gain	$V_O = 15V, R_L = 2K\Omega$	See <sup>(3)</sup>	50		V/mV	4
			See <sup>(3)</sup>	32		V/mV	5, 6
		$V_O = 15V, R_L = 10K\Omega$	See <sup>(3)</sup>	50		V/mV	4
			See <sup>(3)</sup>	32		V/mV	5, 6
- $A_{VS}$	Open Loop Voltage Gain	$V_O = -15V, R_L = 2K\Omega$	See <sup>(3)</sup>	50		V/mV	4
			See <sup>(3)</sup>	32		V/mV	5, 6
		$V_O = -15V, R_L = 10K\Omega$	See <sup>(3)</sup>	50		V/mV	4
			See <sup>(3)</sup>	32		V/mV	5, 6
$A_{VS}$	Open Loop Voltage Gain	$\pm V_{CC} = \pm 5V, V_O = \pm 2V,$ $R_L = 2K\Omega$	See <sup>(3)</sup>	10		V/mV	4, 5, 6
		$\pm V_{CC} = \pm 5V, V_O = \pm 2V,$ $R_L = 10K\Omega$	See <sup>(3)</sup>	10		V/mV	4, 5, 6

(2) Calculated parameter.

(3) Datalog in K = V/mV

## LM118JAN Electrical Characteristics AC Parameters

The following conditions apply to all the following parameters, unless otherwise specified.

AC:  $V_{CC} = \pm 20V$

Symbol	Parameter	Conditions	Notes	Min	Max	Unit	Sub-groups
$NI_{BB}$	Noise Input Broadband	$BW = 10Hz \text{ to } 5KHz,$ $R_S = 0\Omega$			25	$\mu V_{RMS}$	7
$NI_{PC}$	Noise Input Popcorn	$BW = 10Hz \text{ to } 5KHz,$ $R_S = 20K\Omega$			80	$\mu V_{PK}$	7
$TR_{IR}$	Transient Response: Rise Time	$V_I = 50mV,$ PRR = 1KHz			40	nS	7, 8A, 8B
$TR_{OS}$	Transient Response: Overshoot	$V_I = 50mV,$ PRR = 1KHz			50	%	7, 8A, 8B
+SR	Slew Rate	$A_V = 1,$ $V_I = -5V \text{ to } +5V$		50		$V/\mu S$	7, 8B
				40		$V/\mu S$	8A
-SR	Slew Rate	$A_V = 1,$ $V_I = +5V \text{ to } -5V$		50		$V/\mu S$	7, 8B
				40		$V/\mu S$	8A
+ $t_s$	Settling Time	$V_I = -5V \text{ to } +5V$	See <sup>(1)</sup>		800	nS	12
			See <sup>(1)</sup>		1200	nS	13, 14
- $t_s$	Settling Time	$V_I = +5V \text{ to } -5V$	See <sup>(1)</sup>		800	nS	12
			See <sup>(1)</sup>		1200	nS	13, 14

(1) Errorband =  $\pm 2\%$ .

## LM118JAN Electrical Characteristics DC Drift Parameters

The following conditions apply to all the following parameters, unless otherwise specified.

DC:  $V_{CC} = \pm 20V$

Delta calculations performed on JAN S devices at group B, subgroup 5 only.

Symbol	Parameter	Conditions	Notes	Min	Max	Unit	Sub-groups
$V_{IO}$	Input Offset Voltage	$V_{CM} = 0V$		-1.0	1.0	mV	1
$\pm I_B$	Input Bias Current	$V_{CM} = 0V,$ $R_S = 100K\Omega$		-25	25	nA	1

### Typical Performance Characteristics

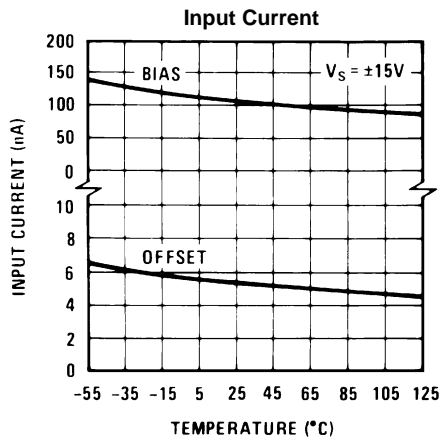


Figure 5.

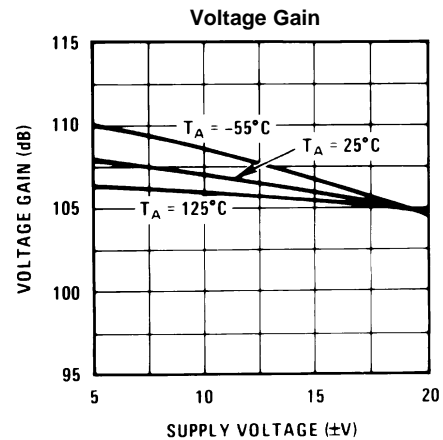


Figure 6.

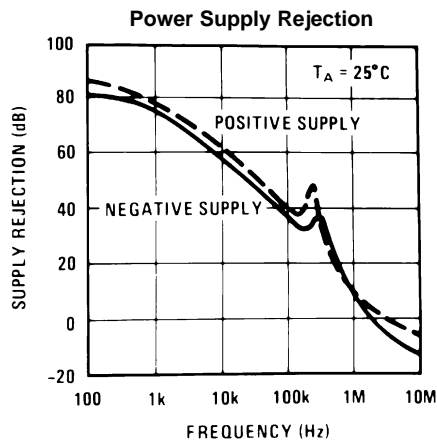


Figure 7.

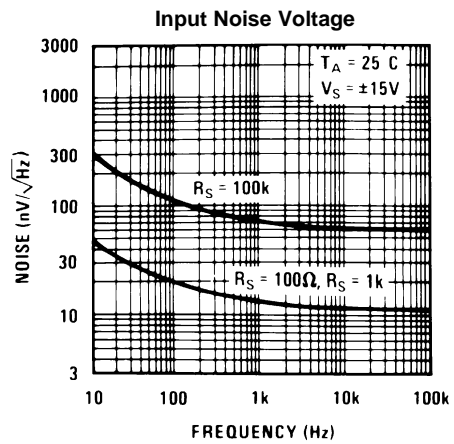


Figure 8.

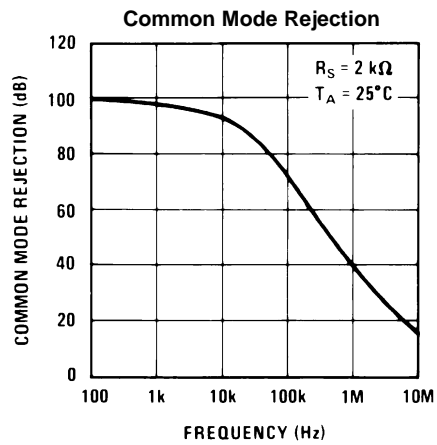


Figure 9.

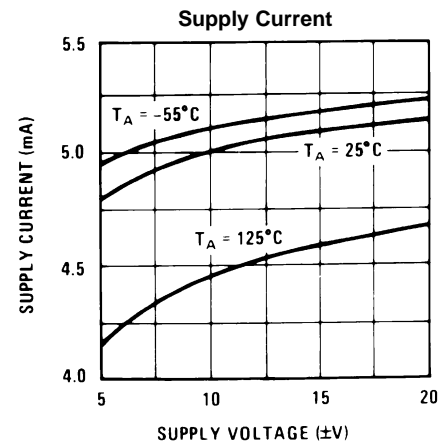


Figure 10.

Typical Performance Characteristics (continued)

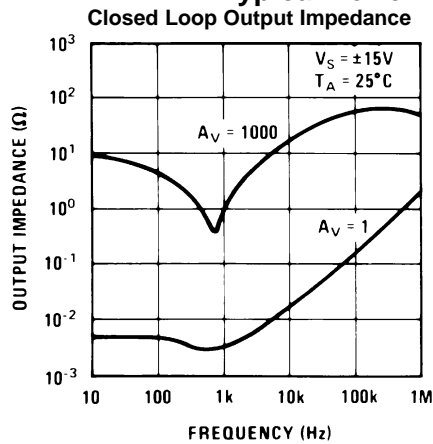


Figure 11.

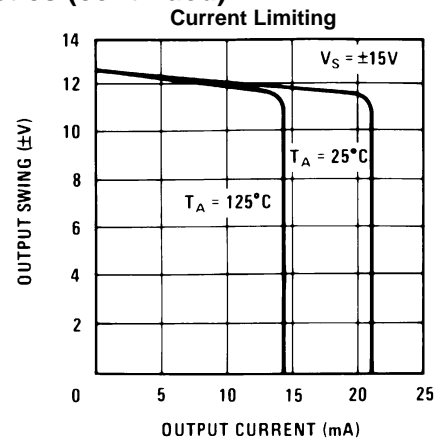


Figure 12.

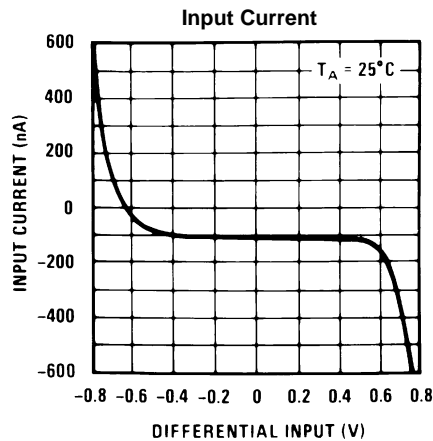


Figure 13.

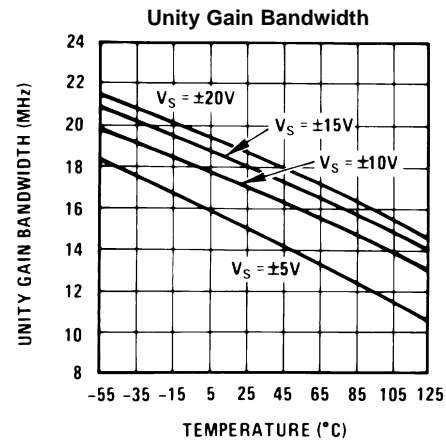


Figure 14.

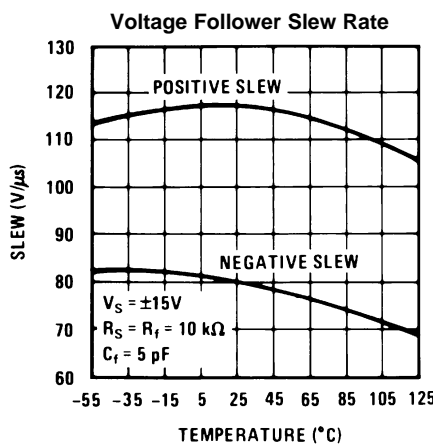


Figure 15.

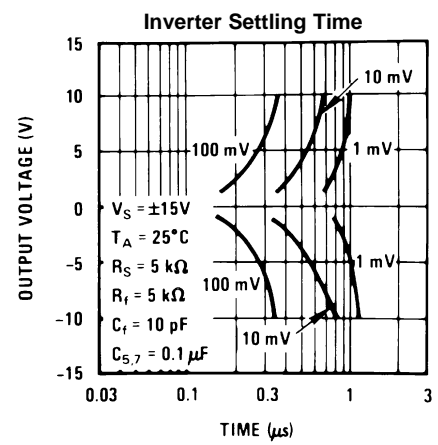
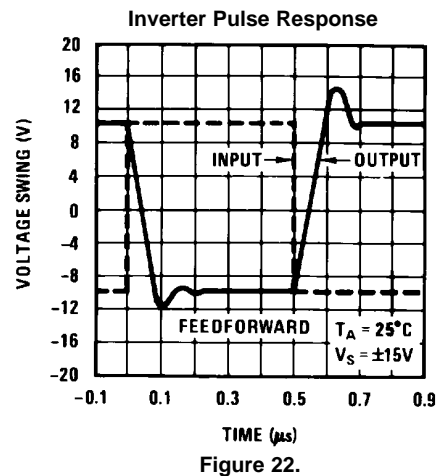
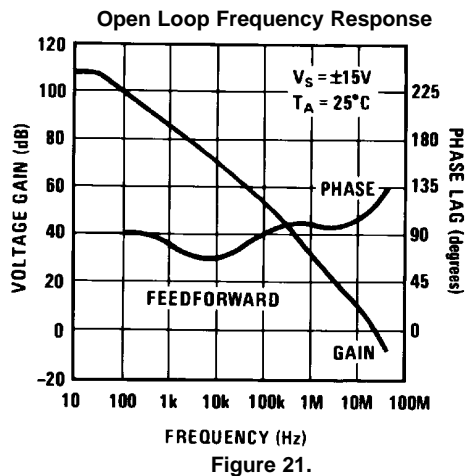
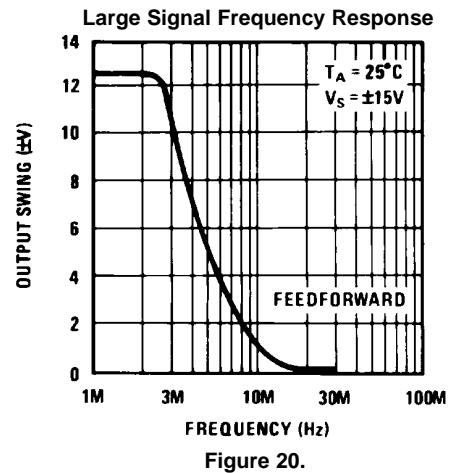
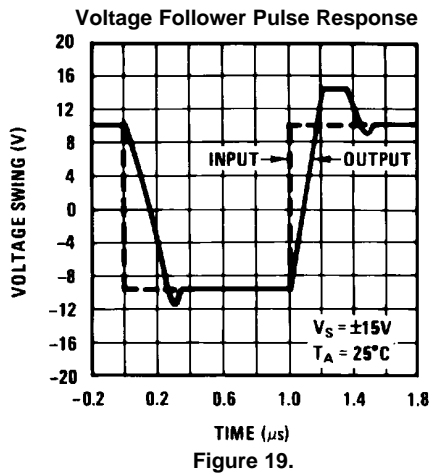
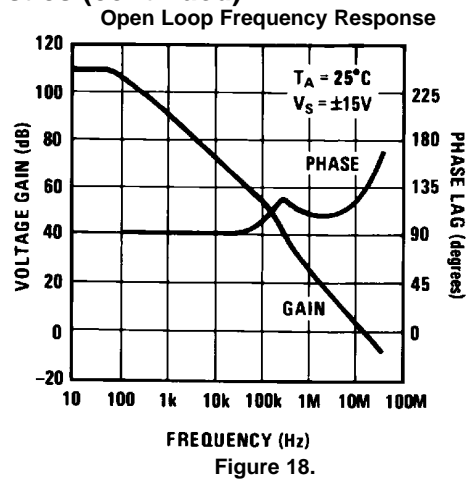
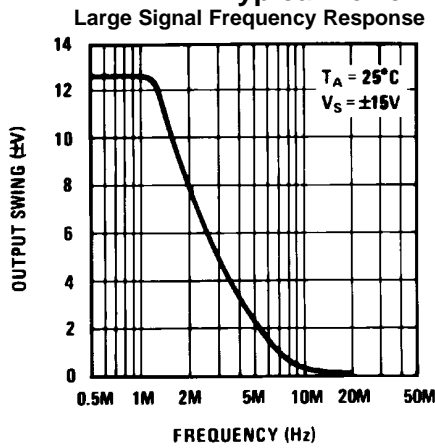


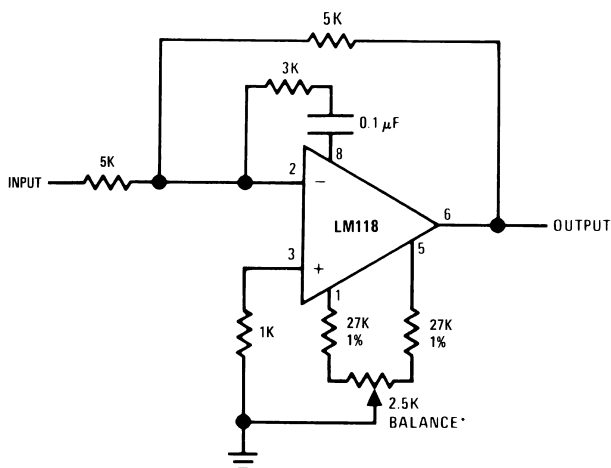
Figure 16.

Typical Performance Characteristics (continued)



AUXILIARY CIRCUITS

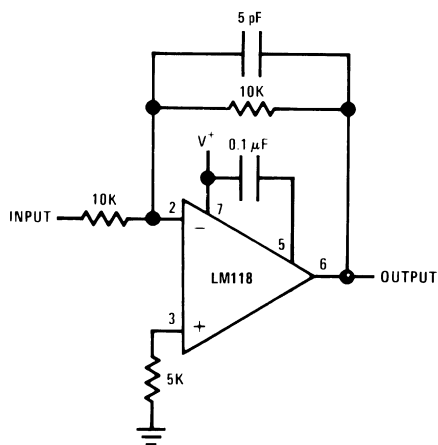
Figure 23. Feedforward Compensation for Greater Inverting Slew Rate



\*Balance circuit necessary for increased slew.

Slew rate typically 150V/μs.

Figure 24. Compensation for Minimum Settling Time



Slew and settling time to 0.1% for a 10V step change is 800 ns.

Figure 25. Offset Balancing

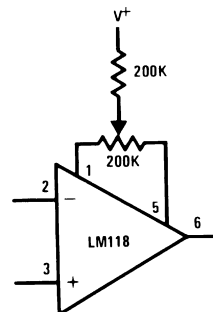


Figure 26. Isolating Large Capacitive Loads

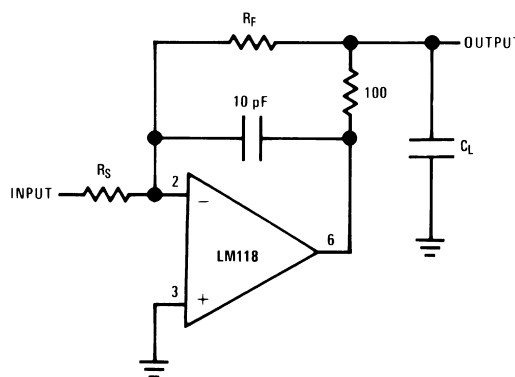
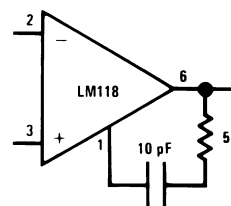


Figure 27. Overcompensation



Typical Applications

Figure 28. Fast Voltage Follower

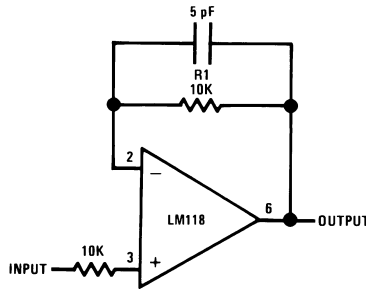
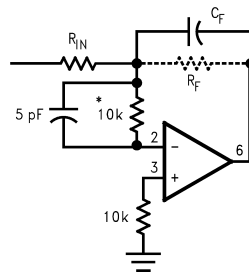


Figure 29. Integrator or Slow Inverter

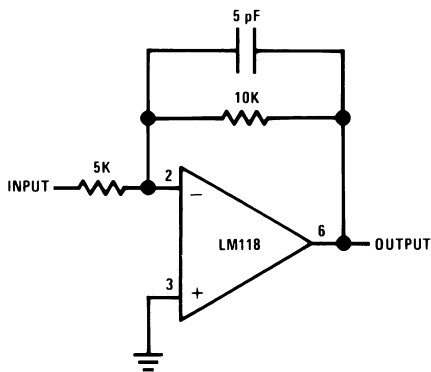


$C_F = \text{Large}$   
 ( $C_F \geq 50 \text{ pF}$ )

\*Do not hard-wire as integrator or slow inverter; insert a 10k-5 pF network in series with the input, to prevent oscillation.

- (1) Do not hard-wire as voltage follower ( $R_1 \geq 5 \text{ k}\Omega$ )

Fast Summing Amplifier



Differential Amplifier

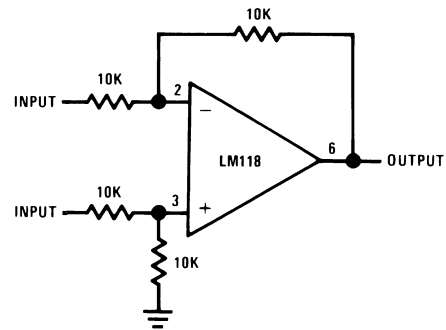


Figure 30. Fast Sample and Hold

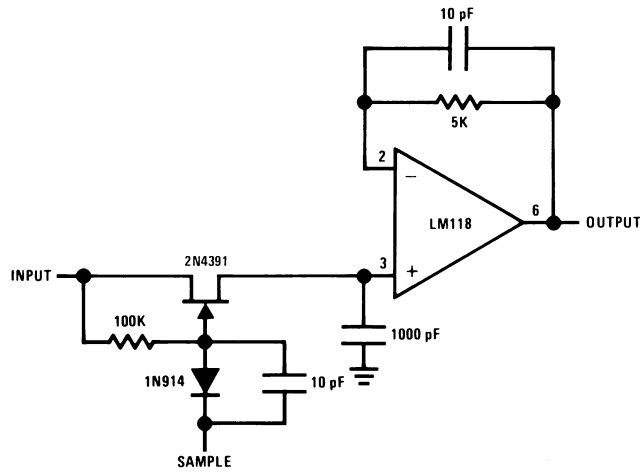
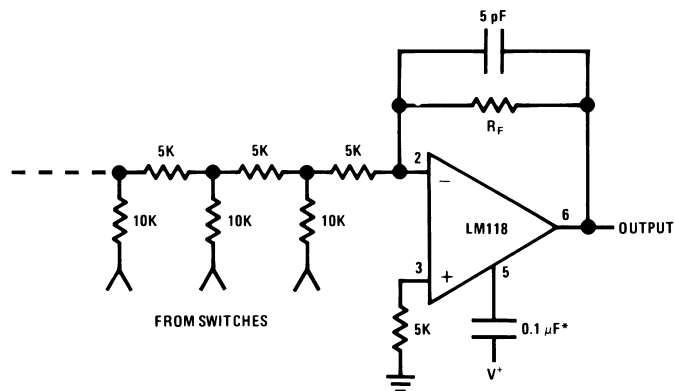
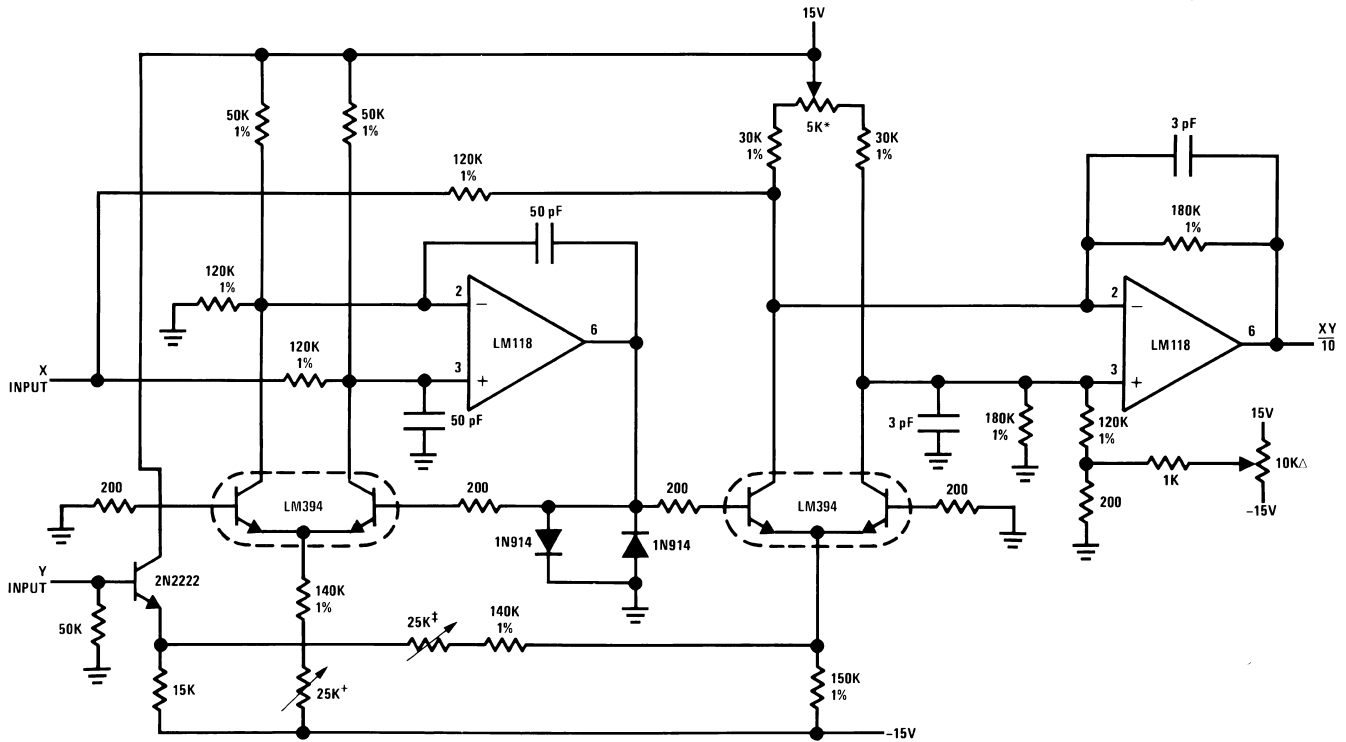


Figure 31. D/A Converter Using Ladder Network



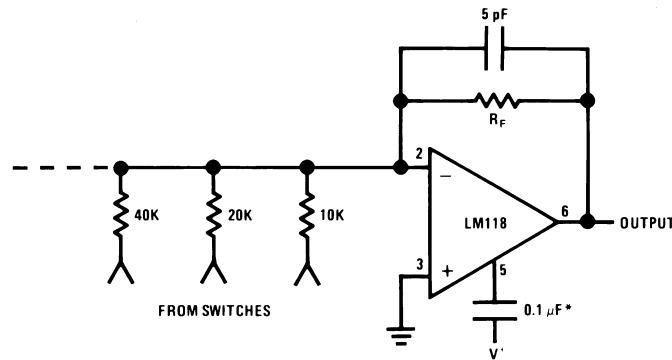
\*Optional—Reduces settling time.

Figure 32. Four Quadrant Multiplier



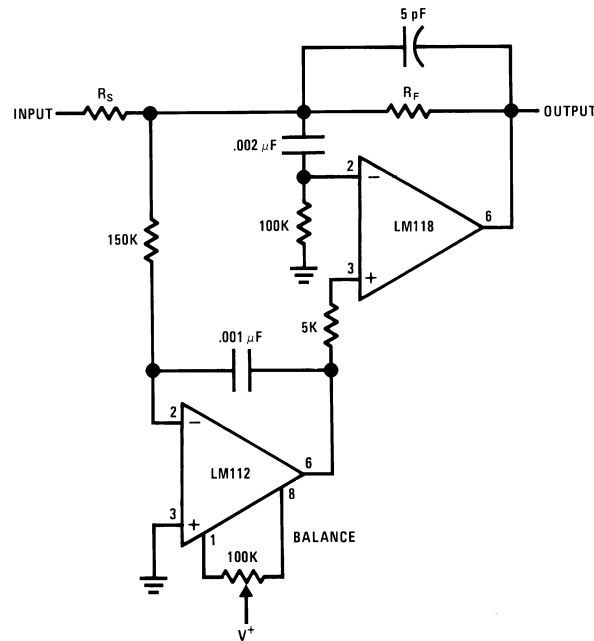
ΔOutput zero.  
 \*"Y" zero  
 + "X" zero  
 ‡Full scale adjust.

Figure 33. D/A Converter Using Binary Weighted Network

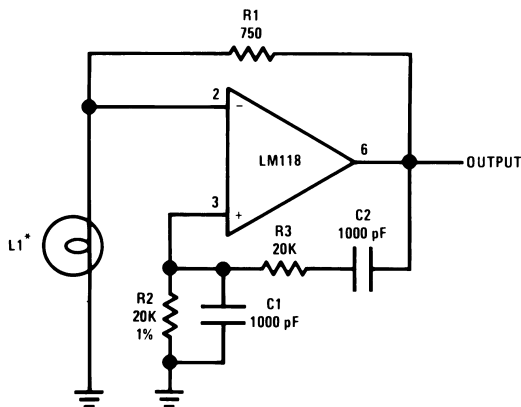


\*Optional—Reduces settling time.

Figure 34. Fast Summing Amplifier with Low Input Current



Wein Bridge Sine Wave Oscillator



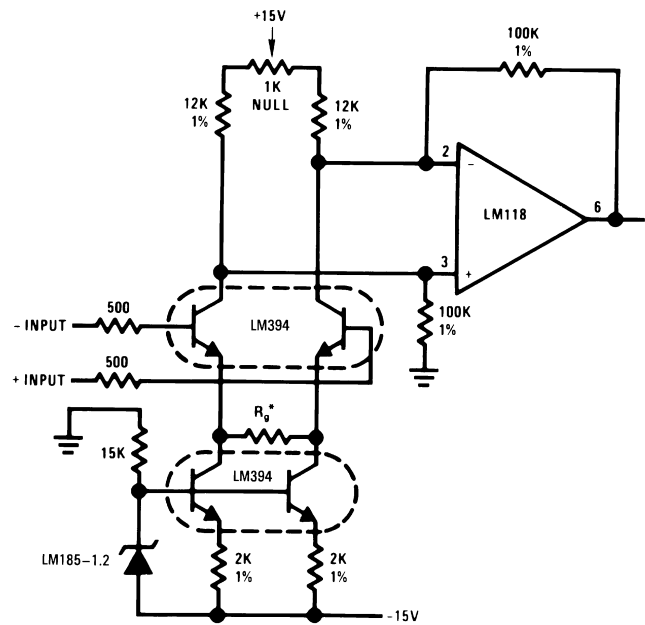
\*L1—10V—14 mA bulb ELDEMA 1869

R1 = R2

C1 = C2

$$f = \frac{1}{2\pi R_2 C_1}$$

Instrumentation Amplifier



$$*Gain \geq \frac{200K}{R_g} \text{ for } 1.5K \leq R_g \leq 200K$$

**REVISION HISTORY SECTION**

<b>Date Released</b>	<b>Revision</b>	<b>Section</b>	<b>Originator</b>	<b>Changes</b>
07/12/05	A	New Release, Corporate format	L. Lytle	1 MDS data sheet, MJLM118–X Rev 0A0 was converted into the Corp. datasheet format. MDS datasheet will be archived.
03/20/2013	A	All Sections		Changed layout of National Data Sheet to TI format

**PACKAGING INFORMATION**

Orderable Device	Status (1)	Package Type	Package Drawing	Pins	Package Qty	Eco Plan (2)	Lead/Ball Finish	MSL Peak Temp (3)	Op Temp (°C)	Top-Side Markings (4)	Samples
JL118BPA	ACTIVE	CDIP	NAB	8	40	TBD	Call TI	Call TI	-55 to 125	JL118BPA Q JM38510/ 10107BPA ACO 10107BPA >T	Samples

(1) The marketing status values are defined as follows:

**ACTIVE:** Product device recommended for new designs.

**LIFEBUY:** TI has announced that the device will be discontinued, and a lifetime-buy period is in effect.

**NRND:** Not recommended for new designs. Device is in production to support existing customers, but TI does not recommend using this part in a new design.

**PREVIEW:** Device has been announced but is not in production. Samples may or may not be available.

**OBSOLETE:** TI has discontinued the production of the device.

(2) Eco Plan - The planned eco-friendly classification: Pb-Free (RoHS), Pb-Free (RoHS Exempt), or Green (RoHS & no Sb/Br) - please check <http://www.ti.com/productcontent> for the latest availability information and additional product content details.

**TBD:** The Pb-Free/Green conversion plan has not been defined.

**Pb-Free (RoHS):** TI's terms "Lead-Free" or "Pb-Free" mean semiconductor products that are compatible with the current RoHS requirements for all 6 substances, including the requirement that lead not exceed 0.1% by weight in homogeneous materials. Where designed to be soldered at high temperatures, TI Pb-Free products are suitable for use in specified lead-free processes.

**Pb-Free (RoHS Exempt):** This component has a RoHS exemption for either 1) lead-based flip-chip solder bumps used between the die and package, or 2) lead-based die adhesive used between the die and leadframe. The component is otherwise considered Pb-Free (RoHS compatible) as defined above.

**Green (RoHS & no Sb/Br):** TI defines "Green" to mean Pb-Free (RoHS compatible), and free of Bromine (Br) and Antimony (Sb) based flame retardants (Br or Sb do not exceed 0.1% by weight in homogeneous material)

(3) MSL, Peak Temp. -- The Moisture Sensitivity Level rating according to the JEDEC industry standard classifications, and peak solder temperature.

(4) Multiple Top-Side Markings will be inside parentheses. Only one Top-Side Marking contained in parentheses and separated by a "~" will appear on a device. If a line is indented then it is a continuation of the previous line and the two combined represent the entire Top-Side Marking for that device.

**Important Information and Disclaimer:** The information provided on this page represents TI's knowledge and belief as of the date that it is provided. TI bases its knowledge and belief on information provided by third parties, and makes no representation or warranty as to the accuracy of such information. Efforts are underway to better integrate information from third parties. TI has taken and continues to take reasonable steps to provide representative and accurate information but may not have conducted destructive testing or chemical analysis on incoming materials and chemicals. TI and TI suppliers consider certain information to be proprietary, and thus CAS numbers and other limited information may not be available for release.

In no event shall TI's liability arising out of such information exceed the total purchase price of the TI part(s) at issue in this document sold by TI to Customer on an annual basis.

**OTHER QUALIFIED VERSIONS OF LM118JAN, LM118JAN-SP :**

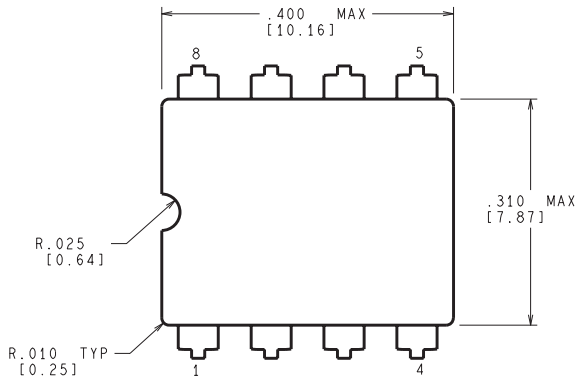
- Military: [LM118JAN](#)

- Space: [LM118JAN-SP](#)

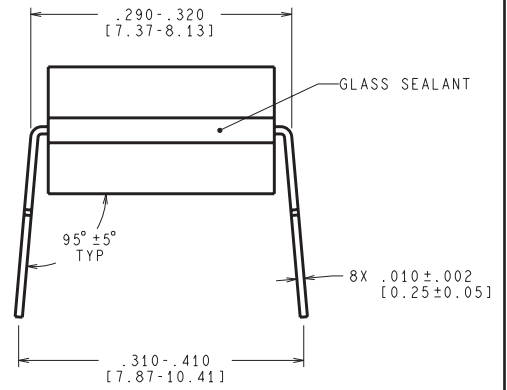
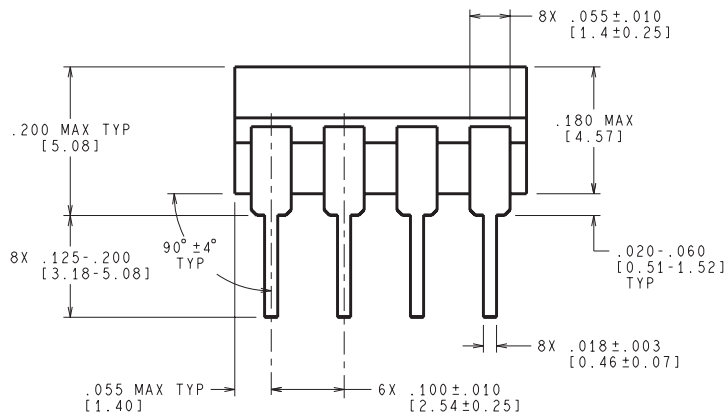
NOTE: Qualified Version Definitions:

- Military - QML certified for Military and Defense Applications
- Space - Radiation tolerant, ceramic packaging and qualified for use in Space-based application

NAB0008A



CONTROLLING DIMENSION IS INCH  
VALUES IN [ ] ARE MILLIMETERS



J08A (Rev M)

## IMPORTANT NOTICE

Texas Instruments Incorporated and its subsidiaries (TI) reserve the right to make corrections, enhancements, improvements and other changes to its semiconductor products and services per JESD46, latest issue, and to discontinue any product or service per JESD48, latest issue. Buyers should obtain the latest relevant information before placing orders and should verify that such information is current and complete. All semiconductor products (also referred to herein as "components") are sold subject to TI's terms and conditions of sale supplied at the time of order acknowledgment.

TI warrants performance of its components to the specifications applicable at the time of sale, in accordance with the warranty in TI's terms and conditions of sale of semiconductor products. Testing and other quality control techniques are used to the extent TI deems necessary to support this warranty. Except where mandated by applicable law, testing of all parameters of each component is not necessarily performed.

TI assumes no liability for applications assistance or the design of Buyers' products. Buyers are responsible for their products and applications using TI components. To minimize the risks associated with Buyers' products and applications, Buyers should provide adequate design and operating safeguards.

TI does not warrant or represent that any license, either express or implied, is granted under any patent right, copyright, mask work right, or other intellectual property right relating to any combination, machine, or process in which TI components or services are used. Information published by TI regarding third-party products or services does not constitute a license to use such products or services or a warranty or endorsement thereof. Use of such information may require a license from a third party under the patents or other intellectual property of the third party, or a license from TI under the patents or other intellectual property of TI.

Reproduction of significant portions of TI information in TI data books or data sheets is permissible only if reproduction is without alteration and is accompanied by all associated warranties, conditions, limitations, and notices. TI is not responsible or liable for such altered documentation. Information of third parties may be subject to additional restrictions.

Resale of TI components or services with statements different from or beyond the parameters stated by TI for that component or service voids all express and any implied warranties for the associated TI component or service and is an unfair and deceptive business practice. TI is not responsible or liable for any such statements.

Buyer acknowledges and agrees that it is solely responsible for compliance with all legal, regulatory and safety-related requirements concerning its products, and any use of TI components in its applications, notwithstanding any applications-related information or support that may be provided by TI. Buyer represents and agrees that it has all the necessary expertise to create and implement safeguards which anticipate dangerous consequences of failures, monitor failures and their consequences, lessen the likelihood of failures that might cause harm and take appropriate remedial actions. Buyer will fully indemnify TI and its representatives against any damages arising out of the use of any TI components in safety-critical applications.

In some cases, TI components may be promoted specifically to facilitate safety-related applications. With such components, TI's goal is to help enable customers to design and create their own end-product solutions that meet applicable functional safety standards and requirements. Nonetheless, such components are subject to these terms.

No TI components are authorized for use in FDA Class III (or similar life-critical medical equipment) unless authorized officers of the parties have executed a special agreement specifically governing such use.

Only those TI components which TI has specifically designated as military grade or "enhanced plastic" are designed and intended for use in military/aerospace applications or environments. Buyer acknowledges and agrees that any military or aerospace use of TI components which have **not** been so designated is solely at the Buyer's risk, and that Buyer is solely responsible for compliance with all legal and regulatory requirements in connection with such use.

TI has specifically designated certain components as meeting ISO/TS16949 requirements, mainly for automotive use. In any case of use of non-designated products, TI will not be responsible for any failure to meet ISO/TS16949.

### Products

Audio	<a href="http://www.ti.com/audio">www.ti.com/audio</a>
Amplifiers	<a href="http://amplifier.ti.com">amplifier.ti.com</a>
Data Converters	<a href="http://dataconverter.ti.com">dataconverter.ti.com</a>
DLP® Products	<a href="http://www.dlp.com">www.dlp.com</a>
DSP	<a href="http://dsp.ti.com">dsp.ti.com</a>
Clocks and Timers	<a href="http://www.ti.com/clocks">www.ti.com/clocks</a>
Interface	<a href="http://interface.ti.com">interface.ti.com</a>
Logic	<a href="http://logic.ti.com">logic.ti.com</a>
Power Mgmt	<a href="http://power.ti.com">power.ti.com</a>
Microcontrollers	<a href="http://microcontroller.ti.com">microcontroller.ti.com</a>
RFID	<a href="http://www.ti-rfid.com">www.ti-rfid.com</a>
OMAP Applications Processors	<a href="http://www.ti.com/omap">www.ti.com/omap</a>
Wireless Connectivity	<a href="http://www.ti.com/wirelessconnectivity">www.ti.com/wirelessconnectivity</a>

### Applications

Automotive and Transportation	<a href="http://www.ti.com/automotive">www.ti.com/automotive</a>
Communications and Telecom	<a href="http://www.ti.com/communications">www.ti.com/communications</a>
Computers and Peripherals	<a href="http://www.ti.com/computers">www.ti.com/computers</a>
Consumer Electronics	<a href="http://www.ti.com/consumer-apps">www.ti.com/consumer-apps</a>
Energy and Lighting	<a href="http://www.ti.com/energy">www.ti.com/energy</a>
Industrial	<a href="http://www.ti.com/industrial">www.ti.com/industrial</a>
Medical	<a href="http://www.ti.com/medical">www.ti.com/medical</a>
Security	<a href="http://www.ti.com/security">www.ti.com/security</a>
Space, Avionics and Defense	<a href="http://www.ti.com/space-avionics-defense">www.ti.com/space-avionics-defense</a>
Video and Imaging	<a href="http://www.ti.com/video">www.ti.com/video</a>

### TI E2E Community

[e2e.ti.com](http://e2e.ti.com)