

QUADRUPLE OPERATIONAL AMPLIFIER

 Check for Samples: [LM124-SP](#), [LM124A-SP](#)

FEATURES

- QML-V Qualified, SMD 5962-7704301VCA, 5962-9950403VCA and 5962-9950403V9B
- Rad-Tolerant: 50 kRad (Si) TID (5962-9950403VCA and 5962-9950403V9B) ⁽¹⁾
 - TID Dose Rate = 0.01 rad/sec (Si)
- Wide Supply Ranges
 - Single Supply: 3 V to 32 V
 - Dual Supplies: ± 1.5 V to ± 16 V
- Low Supply-Current Drain Independent of Supply Voltage: 0.8 mA (Typ)
- Low Input Bias and Offset Parameters
 - Input Offset Voltage: 1 mV Typ
 - Input Offset Current: 2 nA Typ
 - Input Bias Current: 30 nA Typ
- Common-Mode Input Voltage Range Includes Ground, Allowing Direct Sensing Near Ground

- Differential Input Voltage Range Equal to Maximum-Rated Supply Voltage: ± 32 V
- Open-Loop Differential Voltage Amplification: 100 V/mV Typ
- Internal Frequency Compensation

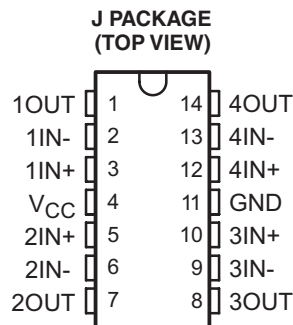

(1) Radiation tolerance is a typical value based upon initial device qualification with dose rate = 0.01 rad/sec. Radiation lot acceptance testing is available - contact factory for details.

DESCRIPTION/ORDERING INFORMATION

These devices consist of four independent high-gain frequency-compensated operational amplifiers that are designed specifically to operate from a single supply over a wide range of voltages. Operation from split supplies also is possible if the difference between the two supplies is 3 V to 32 V, and V_{CC} is at least 1.5 V more positive than the input common-mode voltage. The low supply-current drain is independent of the magnitude of the supply voltage.

Applications include transducer amplifiers, dc amplification blocks, and all the conventional operational-amplifier circuits that now can be more easily implemented in single-supply-voltage systems. For example, the LM124 can be operated directly from the standard 5-V supply that is used in digital systems and provides the required interface electronics, without requiring additional ± 15 -V supplies.

Table 1. ORDERING INFORMATION ⁽¹⁾

T_A	V_{IOmax} AT 25°C	MAX V_{CC}	PACKAGE ⁽²⁾	ORDERABLE PART NUMBER		TOP-SIDE MARKING
–55°C to 125°C	5 mV	30 V	J	LM124	5962-7704301VCA	5962-7704301VCA
	3 mV	30 V		LM124A	5962-9950403VCA ⁽³⁾	5962-9950403VCA
	3 mV	30 V	KGD	5962-9950403V9B ⁽³⁾		N/A

- (1) For the most current package and ordering information, see the Package Option Addendum at the end of this document, or see the TI web site at www.ti.com.
- (2) Package drawings, thermal data, and symbolization are available at www.ti.com/packaging.
- (3) Radiation tolerant



Please be aware that an important notice concerning availability, standard warranty, and use in critical applications of Texas Instruments semiconductor products and disclaimers thereto appears at the end of this data sheet.

BARE DIE INFORMATION

DIE THICKNESS	BACKSIDE FINISH	BACKSIDE POTENTIAL	BON PAD METALLIZATION COMPOSITION	BOND PAD THICKNESS
15 mils	Silicon with backgrind	Floating	AlCu (0.5%)	0.055 mils

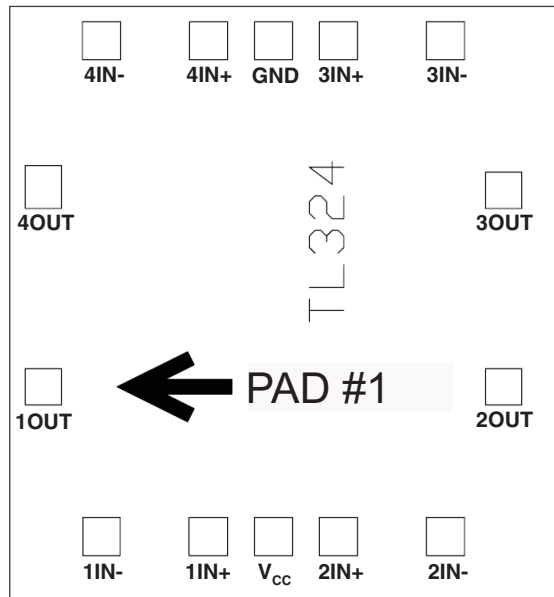
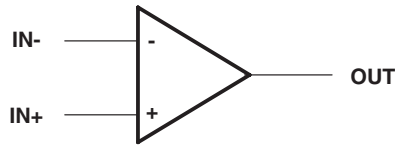

Table 2. Bond Pad Coordinates in Microns

DISCRIPTION	PAD NUMBER	Xmin	Ymin	Xmax	Ymax
1OUT	1	426.72	1249.68	523.24	1346.20
1IN-	2	25.40	1093.47	127	1192.53
1IN+	3	25.40	808.99	127	910.59
V _{CC}	4	25.40	635	127	734.06
2IN+	5	25.40	462.28	127	563.88
2IN-	6	25.40	177.80	127	279.40
2OUT	7	426.72	25.40	523.24	121.92
3OUT	8	949.96	25.40	1046.48	121.92
3IN-	9	1346.20	177.80	1447.80	279.40
3IN+	10	1346.20	462.28	1447.80	563.88
GND	11	1346.20	635	1447.80	736.60
4IN+	12	1346.20	807.72	1447.80	909.32
4IN-	13	1346.20	1092.2	1447.80	1193.80
4OUT	14	949.96	1249.68	1046.48	1346.20

SYMBOL (EACH COMPARATOR)



SCHEMATIC (EACH AMPLIFIER)

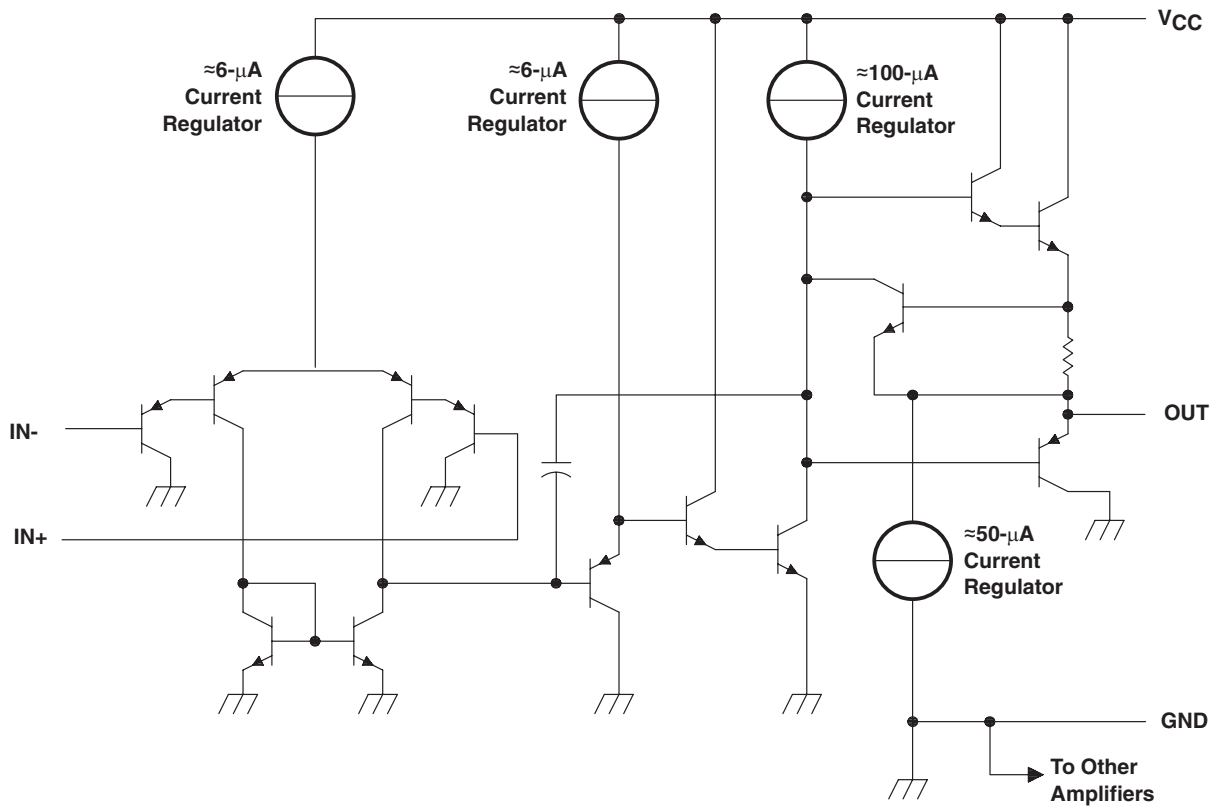

COMPONENT COUNT (total device)	
Epi-FET	1
Transistors	95
Diodes	4
Resistors	11
Capacitors	4

ABSOLUTE MAXIMUM RATINGS⁽¹⁾

over operating free-air temperature range (unless otherwise noted)

		MIN	MAX	UNIT
V _{CC}	Supply voltage ⁽²⁾		±16 or 32	V
V _{ID}	Differential input voltage ⁽³⁾		±32	V
V _I	Input voltage range (either input)	-0.3	32	V
	Duration of output short circuit to ground ⁽⁴⁾		Unlimited	
θ _{JC}	Package thermal impedance, junction to case ^{(5) (6)}		15.05	°C/W
T _J	Operating virtual-junction temperature		150	°C
	Lead temperature 1,6 mm (1/16 in) from case for 60 s		300	°C
T _{stg}	Storage temperature range	-65	150	°C

- (1) Stresses beyond those listed under "absolute maximum ratings" may cause permanent damage to the device. These are stress ratings only, and functional operation of the device at these or any other conditions beyond those indicated under "recommended operating conditions" is not implied. Exposure to absolute-maximum-rated conditions for extended periods may affect device reliability.
- (2) All voltage values, except differential voltages, are with respect to network ground.
- (3) Differential voltages are at IN+ with respect to IN-.
- (4) Short circuits from outputs to V_{CC} can cause excessive heating and eventual destruction.
- (5) Maximum power dissipation is a function of T_J (max), θ_{JC}, and T_C. The maximum allowable power dissipation at any allowable case temperature is P_D = (T_J (max) – T_C)/θ_{JC}. Operating at the absolute maximum T_J of 150°C can affect reliability.
- (6) The package thermal impedance is calculated in accordance with MIL-STD-883.

ELECTRICAL CHARACTERISTICS FOR LM124

 at specified free-air temperature, $V_{CC} = 5\text{ V}$ (unless otherwise noted)

PARAMETER		TEST CONDITIONS ⁽¹⁾		T_A ⁽²⁾	MIN	TYP ⁽³⁾	MAX	UNIT	
V_{IO}	Input offset voltage	$V_{CC} = 5\text{ V to MAX}$, $V_{IC} = V_{ICR\text{ min}}$, $V_O = 1.4\text{ V}$		25°C		3	5	mV	
				Full range			7		
I_{IO}	Input offset current	$V_O = 1.4\text{ V}$		25°C		2	30	nA	
				Full range			100		
I_{IB}	Input bias current	$V_O = 1.4\text{ V}$		25°C		-20	-150	nA	
				Full range			-300		
V_{ICR}	Common-mode input-voltage range	$V_{CC} = 5\text{ V to MAX}$		25°C		0 to $V_{CC} - 1.5$		V	
				Full range			0 to $V_{CC} - 2$		
V_{OH}	High-level output voltage	$R_L = 2\text{ k}\Omega$		25°C		$V_{CC} - 1.5$		V	
		$R_L = 10\text{ k}\Omega$		25°C					
		$V_{CC} = \text{MAX}$	$R_L = 2\text{ k}\Omega$	Full range		26			
			$R_L \geq 10\text{ k}\Omega$	Full range		27	28		
V_{OL}	Low-level output voltage	$R_L \leq 10\text{ k}\Omega$		Full range		5	20	mV	
A_{VD}	Large-signal differential-voltage amplification	$V_{CC} = 15\text{ V}$, $V_O = 1\text{ V to }11\text{ V}$, $R_L \geq 2\text{ k}\Omega$		25°C		50	100	V/mV	
				Full range			25		
CMRR	Common-mode rejection ratio	$V_{IC} = V_{ICR\text{ min}}$		25°C		70	80	dB	
k_{SVR}	Supply-voltage rejection ratio ($\Delta V_{CC}/\Delta V_{IO}$)			25°C		65	100	dB	
V_{O1}/V_{O2}	Crosstalk attenuation	$f = 1\text{ kHz to }20\text{ kHz}$		25°C		120		dB	
I_O	Output current	$V_{CC} = 15\text{ V}$, $V_{ID} = 1\text{ V}$, $V_O = 0$	Source	25°C		-20	-30	-60	mA
				Full range			-10		
		$V_{CC} = 15\text{ V}$, $V_{ID} = -1\text{ V}$, $V_O = 15\text{ V}$	Sink	25°C		10	20		
				Full range			5		
	$V_{ID} = -1\text{ V}$, $V_O = 200\text{ mV}$		25°C			12	30		
I_{OS}	Short-circuit output current	V_{CC} at 5 V, GND at -5 V,	$V_O = 0\text{ V}$	25°C		±40	±60		
I_{CC}	Supply current (four amplifiers)	$V_O = 2.5\text{ V}$,	No load	Full range		0.7	1.2	mA	
		$V_{CC} = \text{MAX}$, $V_O = 0.5 V_{CC}$,	No load	Full range			1.4		3

- (1) All characteristics are measured under open-loop conditions, with zero common-mode input voltage, unless otherwise specified. MAX V_{CC} for testing purposes is 30 V.
 (2) Full range is -55°C to 125°C for LM124.
 (3) All typical values are at $T_A = 25^\circ\text{C}$.

ELECTRICAL CHARACTERISTICS FOR LM124A

at specified free-air temperature, $V_{CC} = 5\text{ V}$ (unless otherwise noted)

PARAMETER		TEST CONDITIONS ⁽¹⁾	T_A ⁽²⁾	MIN	TYP ⁽³⁾	MAX	UNIT
V_{IO}	Input offset voltage	$+V_{CC} = 30\text{ V}$, $-V_{CC} = \text{GND}$, $V_{CM} = 15\text{ V}$	25°C			±3	mV
			Full range			±5	
		$+V_{CC} = 2\text{ V}$, $-V_{CC} = -28\text{ V}$, $V_{CM} = -13\text{ V}$	25°C			±3	mV
			Full range			±5	
		$+V_{CC} = 5\text{ V}$, $-V_{CC} = \text{GND}$, $V_{CM} = 1.4\text{ V}$	25°C			±3	mV
			Full range			±5	
		$+V_{CC} = 2.5\text{ V}$, $-V_{CC} = -2.5\text{ V}$, $V_{CM} = -1.1\text{ V}$	25°C			±3	mV
			Full range			±5	
I_{IO}	Input offset current	$+V_{CC} = 30\text{ V}$, $-V_{CC} = \text{GND}$, $V_{CM} = 15\text{ V}$	25°C			±10	nA
			Full range			±30	
		$+V_{CC} = 2\text{ V}$, $-V_{CC} = -28\text{ V}$, $V_{CM} = -13\text{ V}$	25°C			±10	nA
			Full range			±30	
		$+V_{CC} = 5\text{ V}$, $-V_{CC} = \text{GND}$, $V_{CM} = 1.4\text{ V}$	25°C			±10	nA
			Full range			±30	
		$+V_{CC} = 2.5\text{ V}$, $-V_{CC} = -2.5\text{ V}$, $V_{CM} = -1.1\text{ V}$	25°C			±10	nA
			Full range			±30	
$+I_{IB}$	Input bias current	$+V_{CC} = 30\text{ V}$, $-V_{CC} = \text{GND}$, $V_{CM} = 15\text{ V}$	25°C	-85		0.1	nA
			Full range		-100		
		$+V_{CC} = 2\text{ V}$, $-V_{CC} = -28\text{ V}$, $V_{CM} = -13\text{ V}$	25°C	-50		0.1	nA
			Full range		-100		
		$+V_{CC} = 5\text{ V}$, $-V_{CC} = \text{GND}$, $V_{CM} = 1.4\text{ V}$	25°C	-50		0.1	nA
			Full range		-100		
		$+V_{CC} = 2.5\text{ V}$, $-V_{CC} = -2.5\text{ V}$, $V_{CM} = -1.1\text{ V}$	25°C	-50		0.1	nA
			Full range		-100		
$-I_{IB}$	Input bias current	$+V_{CC} = 30\text{ V}$, $-V_{CC} = \text{GND}$, $V_{CM} = 15\text{ V}$	25°C	-85		0.1	nA
			Full range		-100		
		$+V_{CC} = 2\text{ V}$, $-V_{CC} = -28\text{ V}$, $V_{CM} = -13\text{ V}$	25°C	-50		0.1	nA
			Full range		-100		
		$+V_{CC} = 5\text{ V}$, $-V_{CC} = \text{GND}$, $V_{CM} = -1.4\text{ V}$	25°C	-50		0.1	nA
			Full range		-100		
		$+V_{CC} = 2.5\text{ V}$, $-V_{CC} = -2.5\text{ V}$, $V_{CM} = -1.1\text{ V}$	25°C	-50		0.1	nA
			Full range		-100		
PSRR	Power supply rejection ratio	$-V_{CC} = \text{GND}$, $V_{CM} = 1.4\text{ V}$ $5\text{ V} = V_{CC} = 30\text{ V}$	Full range	-100		100	μV/V
CMRR	Common-mode rejection ratio	$V_{IC} = V_{ICRmin}$	Full range	76			dB
I_{OS}	Short-circuit output current	$+V_{CC} = 30\text{ V}$, $-V_{CC} = \text{GND}$, $V_{OUT} = 25\text{ V}$	Full range	-70			mA

- (1) All characteristics are measured under open-loop conditions, with zero common-mode input voltage, unless otherwise specified. MAX V_{CC} for testing purposes is 30 V.
- (2) Full range is -55°C to 125°C for LM124A.
- (3) All typical values are at $T_A = 25^\circ\text{C}$.

ELECTRICAL CHARACTERISTICS FOR LM124A (continued)

 at specified free-air temperature, $V_{CC} = 5\text{ V}$ (unless otherwise noted)

PARAMETER		TEST CONDITIONS ⁽¹⁾	T_A ⁽²⁾	MIN	TYP ⁽³⁾	MAX	UNIT
I_{CC}	Power supply current	+ $V_{CC} = 30\text{ V}$, - $V_{CC} = \text{GND}$,	125°C			3	mA
			-55°C			4	
$\Delta V_{IO}/\Delta T$	Input offset voltage temperature sensitivity ⁽⁴⁾	+ $V_{CC} = 5\text{ V}$, - $V_{CC} = \text{GND}$, $V_{CM} = 1.4\text{ V}$	125°C, -55°C	-30		30	$\mu\text{V}/^\circ\text{C}$
$\Delta I_{IO}/\Delta T$	Input offset current temperature sensitivity ⁽⁴⁾	+ $V_{CC} = 5\text{ V}$, - $V_{CC} = \text{GND}$, $V_{CM} = 1.4\text{ V}$	125°C	-400		400	$\text{pA}/^\circ\text{C}$
			-55°C	-700		700	
V_{OL}	Low-level output voltage	+ $V_{CC} = 30\text{ V}$, - $V_{CC} = \text{GND}$, $R_L = 10\text{ k}\Omega$	Full range			35	mV
			Full range	+ $V_{CC} = 30\text{ V}$, - $V_{CC} = \text{GND}$, $I_{OL} = 5\text{ mA}$	1.5	V	
					Full range		
V_{OH}	High-level output voltage	+ $V_{CC} = 30\text{ V}$, - $V_{CC} = \text{GND}$, $I_{OH} = 10\text{ mA}$	Full range	27			V
			Full range	2.4			
A_{VS+}	Voltage gain	+ $V_{CC} = 30\text{ V}$, - $V_{CC} = \text{GND}$, $1\text{ V} \leq V_{OUT} \leq 26\text{ V}$ $R_L = 10\text{ k}\Omega$	25°C	50		V/mV	
			Full range	25			
			Full range	+ $V_{CC} = 30\text{ V}$, - $V_{CC} = \text{GND}$, $5\text{ V} \leq V_{OUT} \leq 20\text{ V}$ $R_L = 2\text{ k}\Omega$	25°C		50
Full range	25						
A_{VS}	Voltage gain	+ $V_{CC} = 5\text{ V}$, - $V_{CC} = \text{GND}$, $1\text{ V} \leq V_{OUT} \leq 2.5\text{ V}$ $R_L = 10\text{ k}\Omega$	Full range	10		V/mV	
			Full range	10			
+ V_{OP}	Maximum output voltage swing	+ $V_{CC} = 30\text{ V}$, - $V_{CC} = \text{GND}$, $V_{OUT} = 30\text{ V}$ $R_L = 10\text{ k}\Omega$	Full range	27		V	
			Full range	26			
$TR(t_r)$	Transient response: rise time ⁽⁴⁾	+ $V_{CC} = 30\text{ V}$, - $V_{CC} = \text{GND}$	Full range			1	μs
SR+	Slew rate: rise ⁽⁴⁾	+ $V_{CC} = 30\text{ V}$, - $V_{CC} = \text{GND}$	Full range	0.1			V/ μs
SR-	Slew rate: fall ⁽⁴⁾	+ $V_{CC} = 30\text{ V}$, - $V_{CC} = \text{GND}$	Full range	0.1			V/ μs
NI(BB)	Noise broadband ⁽⁴⁾	+ $V_{CC} = 15\text{ V}$, - $V_{CC} = -15\text{ V}$, BW = 10 Hz to 5 kHz	25°C			15	$\mu\text{V}/\text{rms}$

(4) Parameter characterized over temperature, but not production tested.

ELECTRICAL CHARACTERISTICS FOR LM124A (continued)

at specified free-air temperature, $V_{CC} = 5\text{ V}$ (unless otherwise noted)

PARAMETER		TEST CONDITIONS ⁽¹⁾	T_A ⁽²⁾	MIN	TYP ⁽³⁾	MAX	UNIT
NI(PC)	Noise popcorn ⁽⁵⁾	+VCC = 15 V, -VCC = -15 V, R _S = 20 kΩ, BW = 10 Hz to 5 kHz	25°C			50	μV/peak
CS	Channel separation	+VCC = 30 V, -VCC = GND, R _L = 2 kΩ	25°C	80			dB
		R _L = 2 kΩ, V _{IN} = 1 V and 16 V	25°C	80			

(5) Parameter characterized over temperature, but not production tested.

OPERATING CONDITIONS

$V_{CC} = \pm 15\text{ V}$, $T_A = 25^\circ\text{C}$

PARAMETER		TEST CONDITIONS	TYP	UNIT
SR	Slew rate at unity gain	R _L = 1 MΩ, C _L = 30 pF, V _I = ±10 V (see Figure 1)	0.5	V/μs
B ₁	Unity-gain bandwidth	R _L = 1 MΩ, C _L = 20 pF (see Figure 1)	1.2	MHz
V _n	Equivalent input noise voltage	R _S = 100 Ω, V _I = 0 V, f = 1 kHz (see Figure 2)	35	nV/√Hz

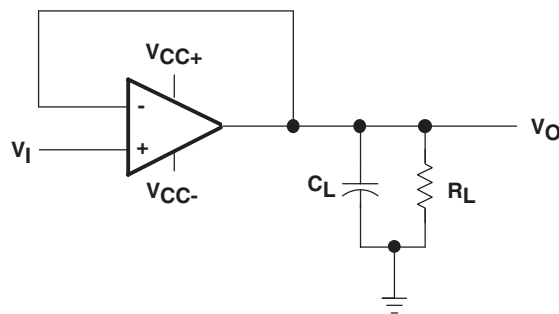

Figure 1. Unity-Gain Amplifier

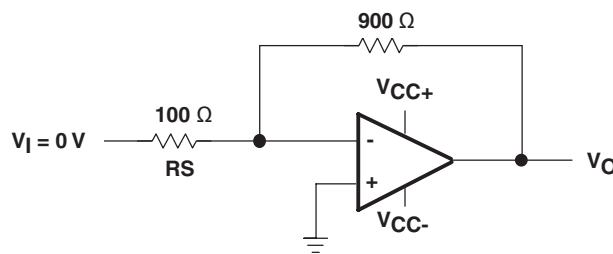

Figure 2. Noise-Test Circuit

PACKAGING INFORMATION

Orderable Device	Status ⁽¹⁾	Package Type	Package Drawing	Pins	Package Qty	Eco Plan ⁽²⁾	Lead/ Ball Finish	MSL Peak Temp ⁽³⁾	Samples (Requires Login)
5962-7704301VCA	ACTIVE	CDIP	J	14	1	TBD	A42	N / A for Pkg Type	
5962-9950403V9B	ACTIVE	XCEPT	KGD	0	100	TBD	Call TI	N / A for Pkg Type	
5962-9950403VCA	ACTIVE	CDIP	J	14	1	TBD	A42	N / A for Pkg Type	

⁽¹⁾ The marketing status values are defined as follows:

ACTIVE: Product device recommended for new designs.

LIFEBUY: TI has announced that the device will be discontinued, and a lifetime-buy period is in effect.

NRND: Not recommended for new designs. Device is in production to support existing customers, but TI does not recommend using this part in a new design.

PREVIEW: Device has been announced but is not in production. Samples may or may not be available.

OBSOLETE: TI has discontinued the production of the device.

⁽²⁾ Eco Plan - The planned eco-friendly classification: Pb-Free (RoHS), Pb-Free (RoHS Exempt), or Green (RoHS & no Sb/Br) - please check <http://www.ti.com/productcontent> for the latest availability information and additional product content details.

TBD: The Pb-Free/Green conversion plan has not been defined.

Pb-Free (RoHS): TI's terms "Lead-Free" or "Pb-Free" mean semiconductor products that are compatible with the current RoHS requirements for all 6 substances, including the requirement that lead not exceed 0.1% by weight in homogeneous materials. Where designed to be soldered at high temperatures, TI Pb-Free products are suitable for use in specified lead-free processes.

Pb-Free (RoHS Exempt): This component has a RoHS exemption for either 1) lead-based flip-chip solder bumps used between the die and package, or 2) lead-based die adhesive used between the die and leadframe. The component is otherwise considered Pb-Free (RoHS compatible) as defined above.

Green (RoHS & no Sb/Br): TI defines "Green" to mean Pb-Free (RoHS compatible), and free of Bromine (Br) and Antimony (Sb) based flame retardants (Br or Sb do not exceed 0.1% by weight in homogeneous material)

⁽³⁾ MSL, Peak Temp. -- The Moisture Sensitivity Level rating according to the JEDEC industry standard classifications, and peak solder temperature.

Important Information and Disclaimer: The information provided on this page represents TI's knowledge and belief as of the date that it is provided. TI bases its knowledge and belief on information provided by third parties, and makes no representation or warranty as to the accuracy of such information. Efforts are underway to better integrate information from third parties. TI has taken and continues to take reasonable steps to provide representative and accurate information but may not have conducted destructive testing or chemical analysis on incoming materials and chemicals. TI and TI suppliers consider certain information to be proprietary, and thus CAS numbers and other limited information may not be available for release.

In no event shall TI's liability arising out of such information exceed the total purchase price of the TI part(s) at issue in this document sold by TI to Customer on an annual basis.

OTHER QUALIFIED VERSIONS OF LM124-SP :

● Catalog: [LM124](#)

● Military: [LM124M](#)

NOTE: Qualified Version Definitions:

- Catalog - TI's standard catalog product
- Military - QML certified for Military and Defense Applications

IMPORTANT NOTICE

Texas Instruments Incorporated and its subsidiaries (TI) reserve the right to make corrections, enhancements, improvements and other changes to its semiconductor products and services per JESD46, latest issue, and to discontinue any product or service per JESD48, latest issue. Buyers should obtain the latest relevant information before placing orders and should verify that such information is current and complete. All semiconductor products (also referred to herein as "components") are sold subject to TI's terms and conditions of sale supplied at the time of order acknowledgment.

TI warrants performance of its components to the specifications applicable at the time of sale, in accordance with the warranty in TI's terms and conditions of sale of semiconductor products. Testing and other quality control techniques are used to the extent TI deems necessary to support this warranty. Except where mandated by applicable law, testing of all parameters of each component is not necessarily performed.

TI assumes no liability for applications assistance or the design of Buyers' products. Buyers are responsible for their products and applications using TI components. To minimize the risks associated with Buyers' products and applications, Buyers should provide adequate design and operating safeguards.

TI does not warrant or represent that any license, either express or implied, is granted under any patent right, copyright, mask work right, or other intellectual property right relating to any combination, machine, or process in which TI components or services are used. Information published by TI regarding third-party products or services does not constitute a license to use such products or services or a warranty or endorsement thereof. Use of such information may require a license from a third party under the patents or other intellectual property of the third party, or a license from TI under the patents or other intellectual property of TI.

Reproduction of significant portions of TI information in TI data books or data sheets is permissible only if reproduction is without alteration and is accompanied by all associated warranties, conditions, limitations, and notices. TI is not responsible or liable for such altered documentation. Information of third parties may be subject to additional restrictions.

Resale of TI components or services with statements different from or beyond the parameters stated by TI for that component or service voids all express and any implied warranties for the associated TI component or service and is an unfair and deceptive business practice. TI is not responsible or liable for any such statements.

Buyer acknowledges and agrees that it is solely responsible for compliance with all legal, regulatory and safety-related requirements concerning its products, and any use of TI components in its applications, notwithstanding any applications-related information or support that may be provided by TI. Buyer represents and agrees that it has all the necessary expertise to create and implement safeguards which anticipate dangerous consequences of failures, monitor failures and their consequences, lessen the likelihood of failures that might cause harm and take appropriate remedial actions. Buyer will fully indemnify TI and its representatives against any damages arising out of the use of any TI components in safety-critical applications.

In some cases, TI components may be promoted specifically to facilitate safety-related applications. With such components, TI's goal is to help enable customers to design and create their own end-product solutions that meet applicable functional safety standards and requirements. Nonetheless, such components are subject to these terms.

No TI components are authorized for use in FDA Class III (or similar life-critical medical equipment) unless authorized officers of the parties have executed a special agreement specifically governing such use.

Only those TI components which TI has specifically designated as military grade or "enhanced plastic" are designed and intended for use in military/aerospace applications or environments. Buyer acknowledges and agrees that any military or aerospace use of TI components which have **not** been so designated is solely at the Buyer's risk, and that Buyer is solely responsible for compliance with all legal and regulatory requirements in connection with such use.

TI has specifically designated certain components which meet ISO/TS16949 requirements, mainly for automotive use. Components which have not been so designated are neither designed nor intended for automotive use; and TI will not be responsible for any failure of such components to meet such requirements.

Products

Audio	www.ti.com/audio
Amplifiers	amplifier.ti.com
Data Converters	dataconverter.ti.com
DLP® Products	www.dlp.com
DSP	dsp.ti.com
Clocks and Timers	www.ti.com/clocks
Interface	interface.ti.com
Logic	logic.ti.com
Power Mgmt	power.ti.com
Microcontrollers	microcontroller.ti.com
RFID	www.ti-rfid.com
OMAP Applications Processors	www.ti.com/omap
Wireless Connectivity	www.ti.com/wirelessconnectivity

Applications

Automotive and Transportation	www.ti.com/automotive
Communications and Telecom	www.ti.com/communications
Computers and Peripherals	www.ti.com/computers
Consumer Electronics	www.ti.com/consumer-apps
Energy and Lighting	www.ti.com/energy
Industrial	www.ti.com/industrial
Medical	www.ti.com/medical
Security	www.ti.com/security
Space, Avionics and Defense	www.ti.com/space-avionics-defense
Video and Imaging	www.ti.com/video

TI E2E Community

e2e.ti.com