

## LM137/LM337-N 3-Terminal Adjustable Negative Regulators

Check for Samples: [LM137](#), [LM337-N](#)

### FEATURES

- **Output Voltage Adjustable from  $-1.2V$  to  $-37V$**
- **1.5A Output Current Specified,  $-55^{\circ}C$  to  $+150^{\circ}C$**
- **Line Regulation Typically 0.01%/V**
- **Load Regulation Typically 0.3%**
- **Excellent Thermal Regulation, 0.002%/W**
- **77 dB Ripple Rejection**
- **Excellent Rejection of Thermal Transients**
- **50 ppm/ $^{\circ}C$  Temperature Coefficient**
- **Temperature-independent Current Limit**
- **Internal Thermal Overload Protection**
- **P<sup>+</sup> Product Enhancement Tested**
- **Standard 3-lead Transistor Package**
- **Output is Short Circuit Protected**

### DESCRIPTION

The LM137/LM337-N are adjustable 3-terminal negative voltage regulators capable of supplying in excess of  $-1.5A$  over an output voltage range of  $-1.2V$  to  $-37V$ . These regulators are exceptionally easy to apply, requiring only 2 external resistors to set the output voltage and 1 output capacitor for frequency compensation. The circuit design has been optimized for excellent regulation and low thermal transients. Further, the LM137 series features internal current limiting, thermal shutdown and safe-area compensation, making them virtually blowout-proof against overloads.

The LM137/LM337-N serve a wide variety of applications including local on-card regulation, programmable-output voltage regulation or precision current regulation. The LM137/LM337-N are ideal complements to the LM117/LM317 adjustable positive regulators.

**Table 1. LM137 Series Packages and Power Capability**

Device	Package	Rated Power Dissipation	Design Load Current
LM137/337-N	TO-3 (K)	20W	1.5A
	TO (NDT)	2W	0.5A
LM337-N	TO-220 (NDE)	15W	1.5A
LM337-N	SOT-223 (DCY)	2W	1A



Please be aware that an important notice concerning availability, standard warranty, and use in critical applications of Texas Instruments semiconductor products and disclaimers thereto appears at the end of this data sheet.

All trademarks are the property of their respective owners.

Typical Applications

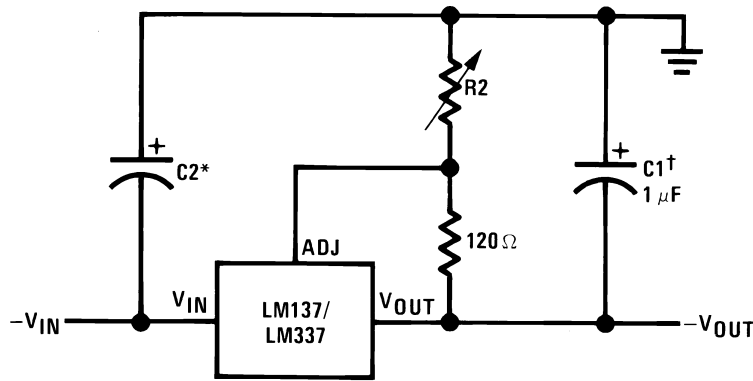

Full output current not available at high input-output voltages

$$-V_{OUT} = -1.25V \left( 1 + \frac{R2}{120} \right) + (-I_{ADJ} \times R2)$$

†C1 = 1 μF solid tantalum or 10 μF aluminum electrolytic required for stability

\*C2 = 1 μF solid tantalum is required only if regulator is more than 4" from power-supply filter capacitor

Output capacitors in the range of 1 μF to 1000 μF of aluminum or tantalum electrolytic are commonly used to provide improved output impedance and rejection of transients

Figure 1. Adjustable Negative Voltage Regulator

Comparison between SOT-223 and D-Pak (TO-252) Packages

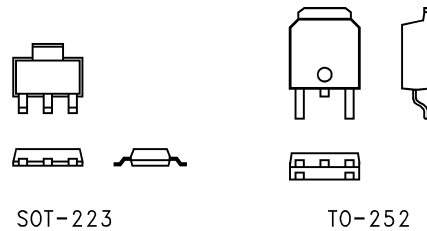

Figure 2. Scale 1:1



These devices have limited built-in ESD protection. The leads should be shorted together or the device placed in conductive foam during storage or handling to prevent electrostatic damage to the MOS gates.

## ABSOLUTE MAXIMUM RATINGS<sup>(1)(2)</sup>

Power Dissipation	Internally Limited
Input-Output Voltage Differential	40V
Operating Junction Temperature Range	
LM137	-55°C to +150°C
LM337-N	0°C to +125°C
LM337I	-40°C to +125°C
Storage Temperature	-65°C to +150°C
Lead Temperature (Soldering, 10 sec.)	300°C
Plastic Package (Soldering, 4 sec.)	260°C
ESD Rating	2k Volts

- (1) Refer to RETS137H drawing for LM137H or RETS137K drawing for LM137K military specifications.  
 (2) Unless otherwise specified, these specifications apply  $-55^{\circ}\text{C} \leq T_j \leq +150^{\circ}\text{C}$  for the LM137,  $0^{\circ}\text{C} \leq T_j \leq +125^{\circ}\text{C}$  for the LM337-N;  $V_{\text{IN}} - V_{\text{OUT}} = 5\text{V}$ ; and  $I_{\text{OUT}} = 0.1\text{A}$  for the TO package and  $I_{\text{OUT}} = 0.5\text{A}$  for the TO-3, SOT-223 and TO-220 packages. Although power dissipation is internally limited, these specifications are applicable for power dissipations of 2W for the TO and SOT-223 (see [APPLICATION HINTS](#)), and 20W for the TO-3, and TO-220.  $I_{\text{MAX}}$  is 1.5A for the TO-3, SOT-223 and TO-220 packages, and 0.2A for the TO package.

## ELECTRICAL CHARACTERISTICS<sup>(1)</sup>

Parameter	Conditions	LM137			LM337			Units
		Min	Typ	Max	Min	Typ	Max	
Line Regulation	$T_j = 25^{\circ}\text{C}$ , $3\text{V} \leq  V_{\text{IN}} - V_{\text{OUT}}  \leq 40\text{V}$ (2) $I_{\text{L}} = 10\text{ mA}$		0.01	0.02		0.01	0.04	%/V
Load Regulation	$T_j = 25^{\circ}\text{C}$ , $10\text{ mA} \leq I_{\text{OUT}} \leq I_{\text{MAX}}$		0.3	0.5		0.3	1.0	%
Thermal Regulation	$T_j = 25^{\circ}\text{C}$ , 10 ms Pulse		0.002	0.02		0.003	0.04	%/W
Adjustment Pin Current			65	100		65	100	$\mu\text{A}$
Adjustment Pin Current Charge	$10\text{ mA} \leq I_{\text{L}} \leq I_{\text{MAX}}$ $3.0\text{V} \leq  V_{\text{IN}} - V_{\text{OUT}}  \leq 40\text{V}$ , $T_{\text{A}} = 25^{\circ}\text{C}$		2	5		2	5	$\mu\text{A}$
Reference Voltage	$T_j = 25^{\circ}\text{C}$ (3)	-1.225	-1.250	-1.275	-1.213	-1.250	-1.287	V
	$3\text{V} \leq  V_{\text{IN}} - V_{\text{OUT}}  \leq 40\text{V}$ , (3) $10\text{ mA} \leq I_{\text{OUT}} \leq I_{\text{MAX}}$ , $P \leq P_{\text{MAX}}$	-1.200	-1.250	-1.300	-1.200	-1.250	-1.300	V
Line Regulation	$3\text{V} \leq  V_{\text{IN}} - V_{\text{OUT}}  \leq 40\text{V}$ , (2)		0.02	0.05		0.02	0.07	%/V
Load Regulation	$10\text{ mA} \leq I_{\text{OUT}} \leq I_{\text{MAX}}$ , (2)		0.3	1		0.3	1.5	%
Temperature Stability	$T_{\text{MIN}} \leq T_j \leq T_{\text{MAX}}$		0.6			0.6		%
Minimum Load Current	$ V_{\text{IN}} - V_{\text{OUT}}  \leq 40\text{V}$		2.5	5		2.5	10	mA
	$ V_{\text{IN}} - V_{\text{OUT}}  \leq 10\text{V}$		1.2	3		1.5	6	mA

- (1) Unless otherwise specified, these specifications apply  $-55^{\circ}\text{C} \leq T_j \leq +150^{\circ}\text{C}$  for the LM137,  $0^{\circ}\text{C} \leq T_j \leq +125^{\circ}\text{C}$  for the LM337-N;  $V_{\text{IN}} - V_{\text{OUT}} = 5\text{V}$ ; and  $I_{\text{OUT}} = 0.1\text{A}$  for the TO package and  $I_{\text{OUT}} = 0.5\text{A}$  for the TO-3, SOT-223 and TO-220 packages. Although power dissipation is internally limited, these specifications are applicable for power dissipations of 2W for the TO and SOT-223 (see [APPLICATION HINTS](#)), and 20W for the TO-3, and TO-220.  $I_{\text{MAX}}$  is 1.5A for the TO-3, SOT-223 and TO-220 packages, and 0.2A for the TO package.  
 (2) Regulation is measured at constant junction temperature, using pulse testing with a low duty cycle. Changes in output voltage due to heating effects are covered under the specification for thermal regulation. Load regulation is measured on the output pin at a point  $\frac{1}{8}$  in. below the base of the TO-3 and TO packages.  
 (3) Selected devices with tightened tolerance reference voltage available.

**ELECTRICAL CHARACTERISTICS<sup>(1)</sup> (continued)**

Parameter	Conditions	LM137			LM337			Units
		Min	Typ	Max	Min	Typ	Max	
Current Limit	$ V_{IN} - V_{OUT}  \leq 15V$							
	K, DCY and NDE Package	1.5	2.2	3.5	1.5	2.2	3.7	A
	NDT Package	0.5	0.8	1.8	0.5	0.8	1.9	A
	$ V_{IN} - V_{OUT}  = 40V, T_j = 25^\circ C$							
	K, DCY and NDE Package	0.24	0.4		0.15	0.4		A
	NDT Package	0.15	0.17		0.10	0.17		A
RMS Output Noise, % of $V_{OUT}$	$T_j = 25^\circ C, 10 \text{ Hz} \leq f \leq 10 \text{ kHz}$		0.003			0.003		%
Ripple Rejection Ratio	$V_{OUT} = -10V, f = 120 \text{ Hz}$		60			60		dB
	$C_{ADJ} = 10 \mu F$	66	77		66	77		dB
Long-Term Stability	$T_j = 125^\circ C, 1000 \text{ Hours}$		0.3	1		0.3	1	%
Thermal Resistance, Junction to Case	NDT Package		12	15		12	15	$^\circ C/W$
	K Package		2.3	3		2.3	3	$^\circ C/W$
	NDE Package					4		$^\circ C/W$
Thermal Resistance, Junction to Ambient (No Heat Sink)	NDT Package		140			140		$^\circ C/W$
	K Package		35			35		$^\circ C/W$
	NDE Package					50		$^\circ C/W$
	DCY Package					170		$^\circ C/W$

**SCHEMATIC DIAGRAM**

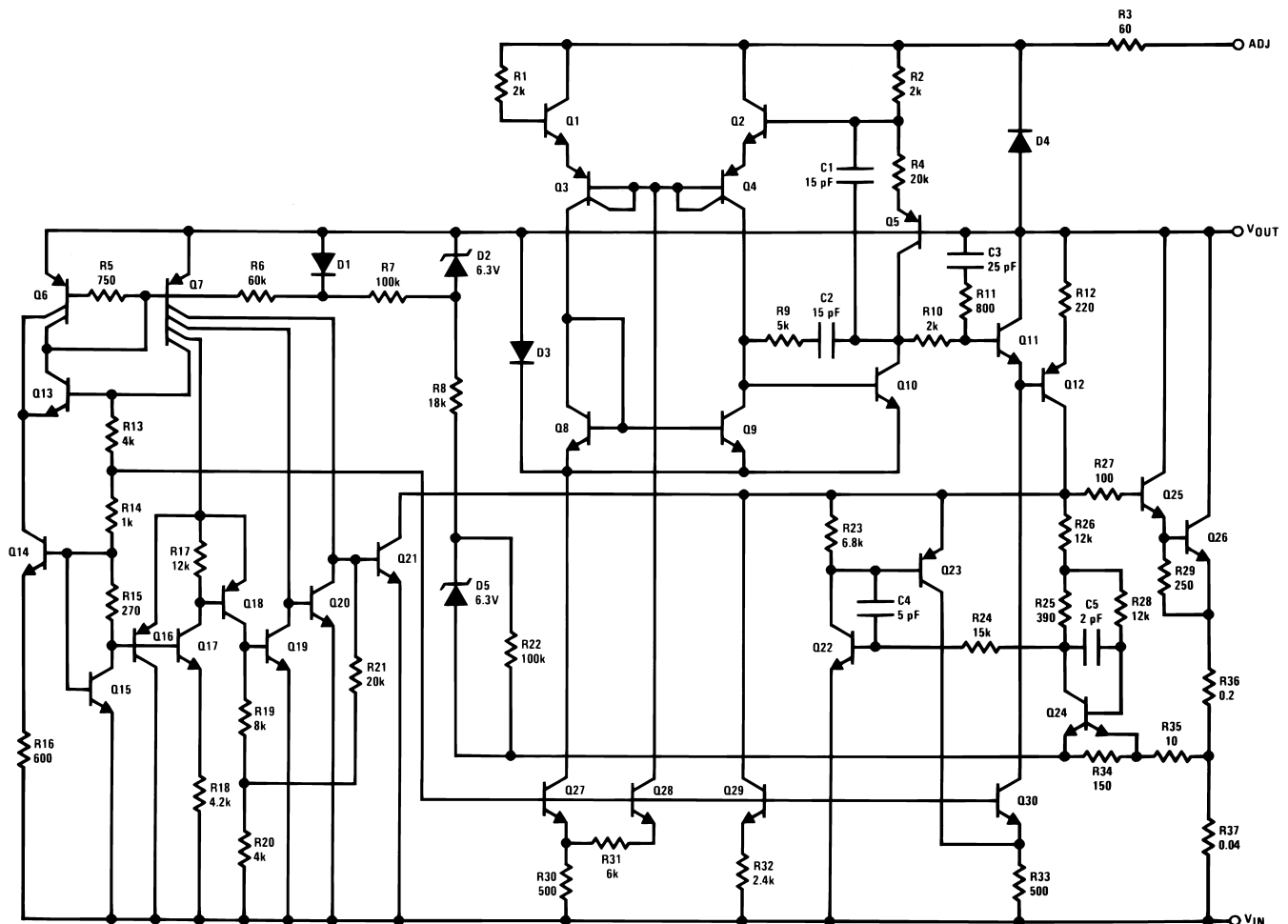

**Thermal Regulation**

When power is dissipated in an IC, a temperature gradient occurs across the IC chip affecting the individual IC circuit components. With an IC regulator, this gradient can be especially severe since power dissipation is large. Thermal regulation is the effect of these temperature gradients on output voltage (in percentage output change) per Watt of power change in a specified time. Thermal regulation error is independent of electrical regulation or temperature coefficient, and occurs within 5 ms to 50 ms after a change in power dissipation. Thermal regulation depends on IC layout as well as electrical design. The thermal regulation of a voltage regulator is defined as the percentage change of  $V_{OUT}$ , per Watt, within the first 10 ms after a step of power is applied. The LM137's specification is 0.02%/W, max.

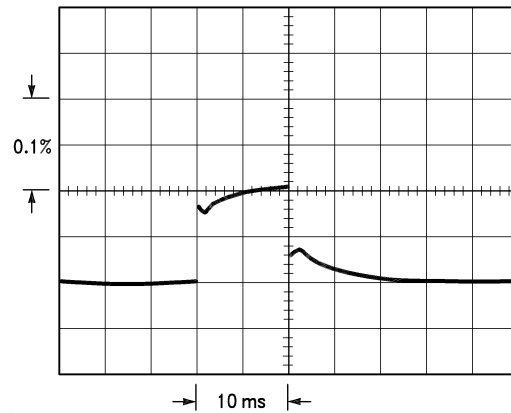

LM137,  $V_{OUT} = -10V$   
 $V_{IN} - V_{OUT} = -40V$   
 $I_{IL} = 0A \rightarrow 0.25A \rightarrow 0A$   
 Vertical sensitivity, 5 mV/div

**Figure 3.**

In [Figure 3](#), a typical LM137's output drifts only 3 mV (or 0.03% of  $V_{OUT} = -10V$ ) when a 10W pulse is applied for 10 ms. This performance is thus well inside the specification limit of  $0.02\%/W \times 10W = 0.2\%$  max. When the 10W pulse is ended, the thermal regulation again shows a 3 mV step at the LM137 chip cools off. Note that the load regulation error of about 8 mV (0.08%) is additional to the thermal regulation error. In [Figure 4](#), when the 10W pulse is applied for 100 ms, the output drifts only slightly beyond the drift in the first 10 ms, and the thermal error stays well within 0.1% (10 mV).

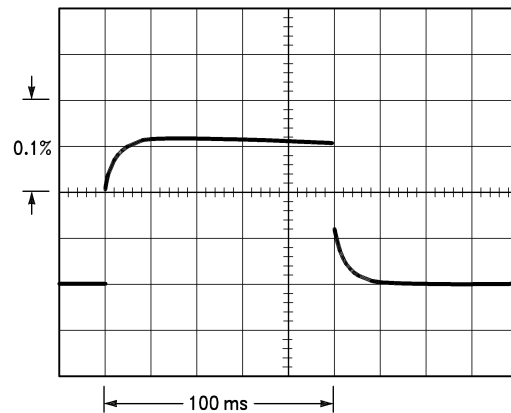

LM137,  $V_{OUT} = -10V$   
 $V_{IN} - V_{OUT} = -40V$   
 $I_L = 0A \rightarrow 0.25A \rightarrow 0A$   
 Horizontal sensitivity, 20 ms/div

**Figure 4.**

Connection Diagrams

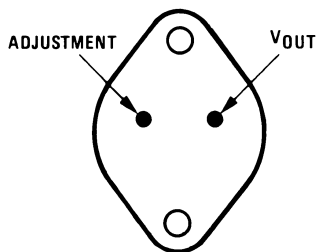

Case is Input

**Figure 5. TO-3  
Metal Can Package  
Bottom View**  
See Package Number K0002C  
See Package Number NDS0002A

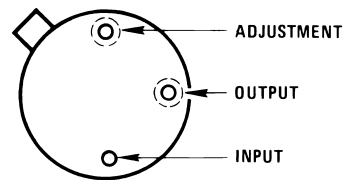

Case Is Input

See STD Mil DWG 5962P99517 for  
Radiation Tolerant Devices

**Figure 6. TO  
Metal Can Package  
Bottom View**  
See Package Number NDT0003A

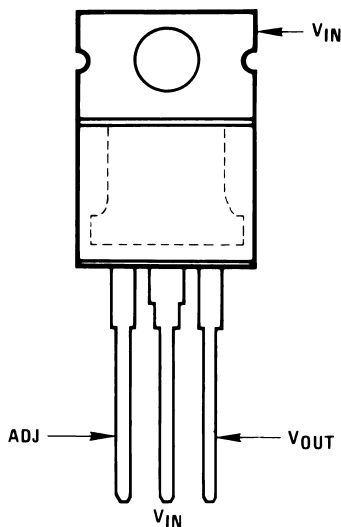

**Figure 7. TO-220  
Plastic Package  
Front View**  
See Package Number NDE0003B

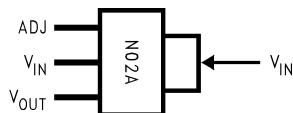

**Figure 8. 3-Lead SOT-223  
Front View**  
Package Marked N02A  
See Package Number DCY0004A

## APPLICATION HINTS

When a value for  $\theta_{(H-A)}$  is found using the equation shown, a heatsink must be selected that has a value that is less than or equal to this number.

### HEATSINKING SOT-223 PACKAGE PARTS

The SOT-223 (“DCY”) packages use a copper plane on the PCB and the PCB itself as a heatsink. To optimize the heat sinking ability of the plane and PCB, solder the tab of the package to the plane.

Figure 9 and Figure 10 show the information for the SOT-223 package. Figure 10 assumes a  $\theta_{(J-A)}$  of 75°C/W for 1 ounce copper and 51°C/W for 2 ounce copper and a maximum junction temperature of 125°C.

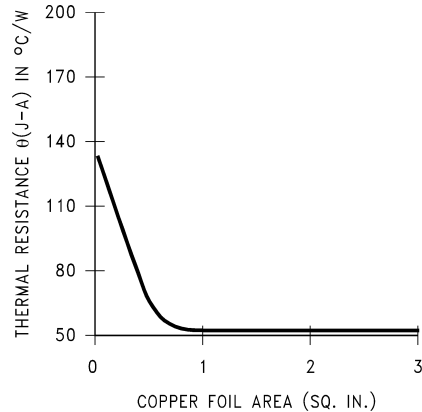

Figure 9.  $\theta_{(J-A)}$  vs Copper (2 ounce) Area for the SOT-223 Package

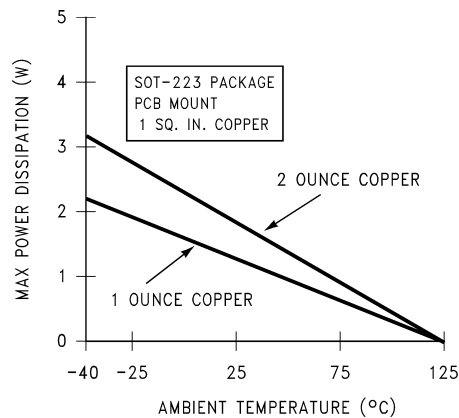
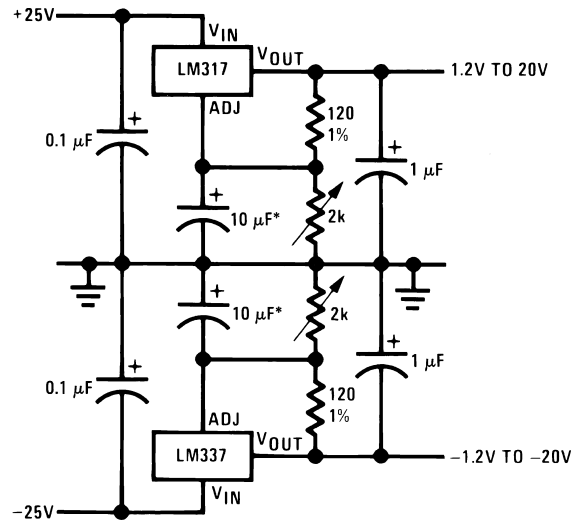

Figure 10. Maximum Power Dissipation vs.  $T_{AMB}$  for the SOT-223 Package

Please see AN-1028 (literature number [SNVA036](#)) for power enhancement techniques to be used with the SOT-223 package.

Typical Applications

Figure 11. Adjustable Lab Voltage Regulator



Full output current not available  
at high input-output voltages

\*The 10 µF capacitors are optional to improve ripple rejection

Figure 12. Current Regulator

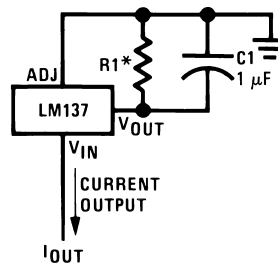

$$I_{OUT} = \frac{1.250V}{R1}$$

\*0.8Ω ≤ R1 ≤ 120Ω

Figure 13. Negative Regulator with Protection Diodes

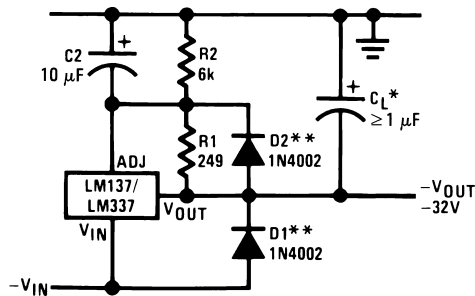

\*When CL is larger than 20 µF, D1 protects the LM137 in case the input supply is shorted

\*\*When C2 is larger than 10 µF and -VOUT is larger than -25V, D2 protects the LM137 in case the output is shorted

Figure 14. -5.2V Regulator with Electronic Shutdown\*

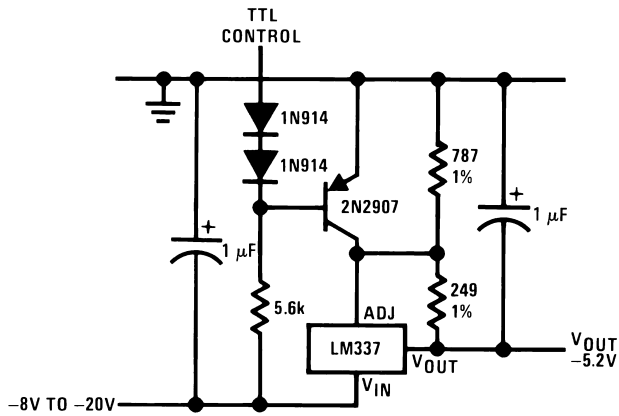

\*Minimum output  $\approx -1.3V$  when control input is low

Figure 15. Adjustable Current Regulator

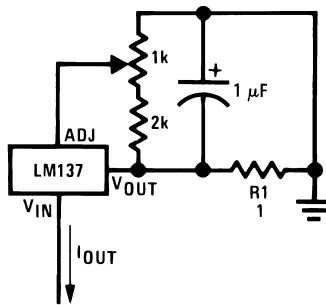

$$I_{OUT} = \left( \frac{1.5V}{R1} \right) \pm 15\% \text{ adjustable}$$

Figure 16. High Stability -10V Regulator

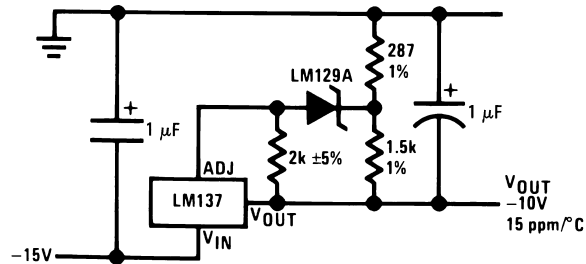

TYPICAL PERFORMANCE CHARACTERISTICS

(K Steel and NDE Packages)

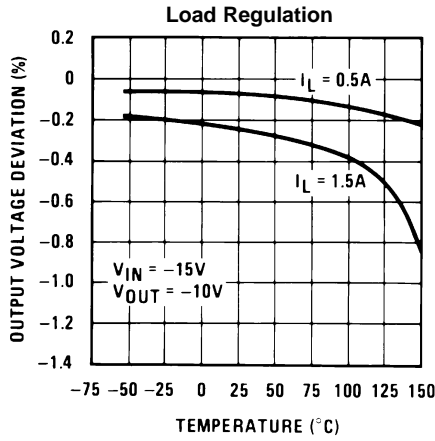

Figure 17.

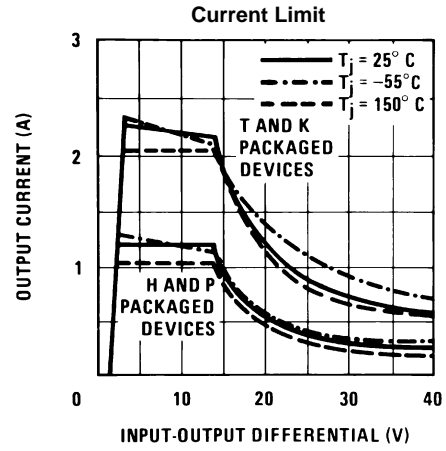

Figure 18.

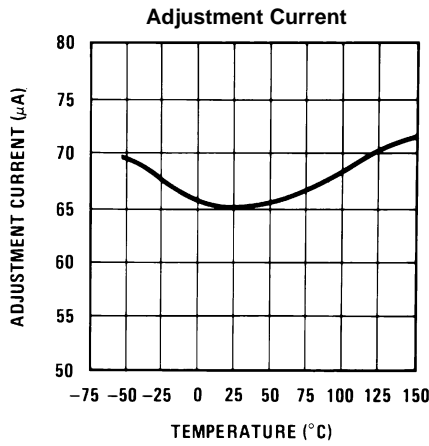

Figure 19.

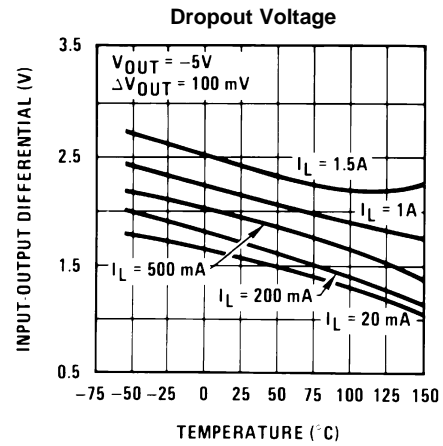

Figure 20.

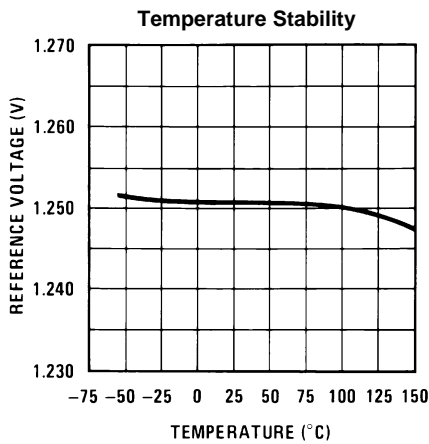

Figure 21.

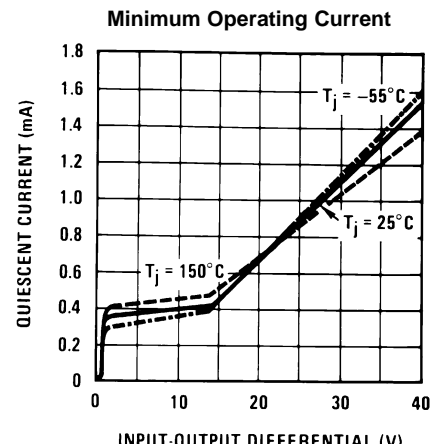

Figure 22.

TYPICAL PERFORMANCE CHARACTERISTICS (continued)

(K Steel and NDE Packages)

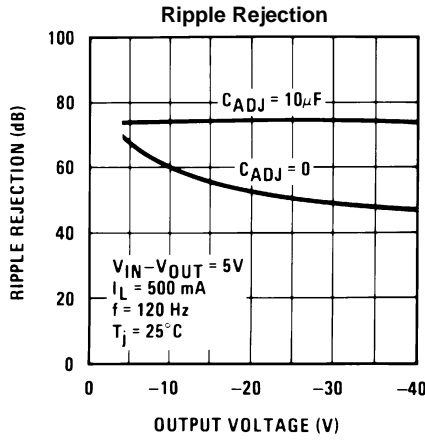

Figure 23.

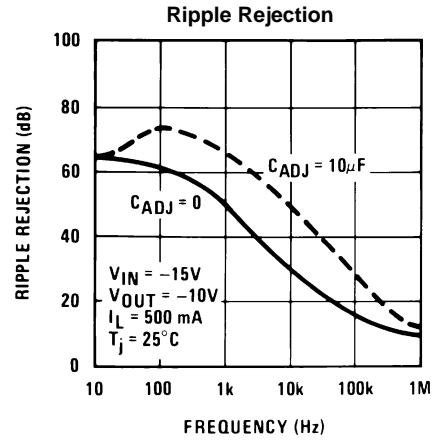

Figure 24.

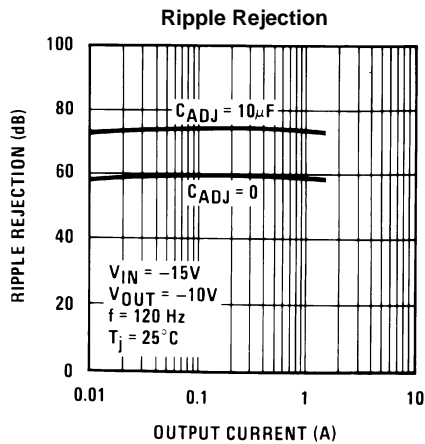

Figure 25.

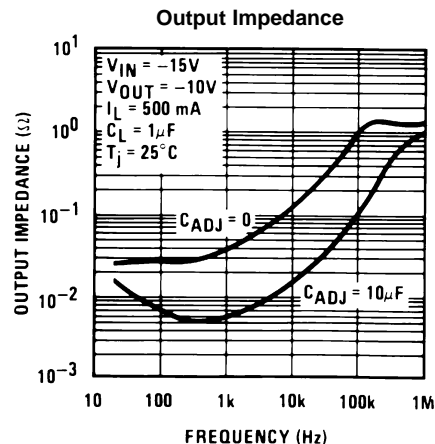

Figure 26.

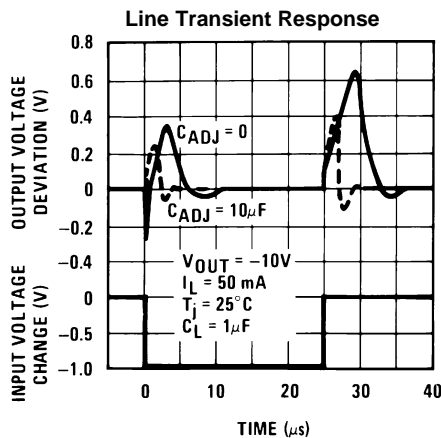

Figure 27.

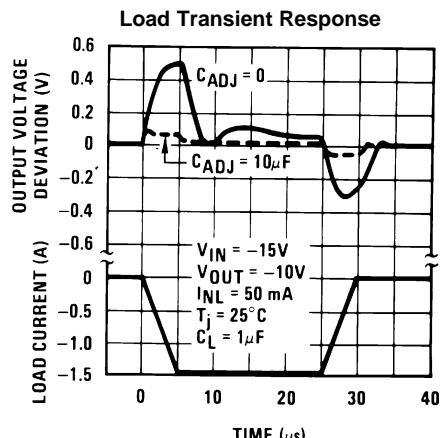

Figure 28.

---

## REVISION HISTORY

Changes from Revision C (April 2013) to Revision D	Page
• Changed layout of National Data Sheet to TI format .....	<a href="#">12</a>

---

**PACKAGING INFORMATION**

Orderable Device	Status (1)	Package Type	Package Drawing	Pins	Package Qty	Eco Plan (2)	Lead/Ball Finish (6)	MSL Peak Temp (3)	Op Temp (°C)	Device Marking (4/5)	Samples
LM137H	ACTIVE	TO	NDT	3	500	Green (RoHS & no Sb/Br)	AU	Level-1-NA-UNLIM	-55 to 150	LM137HP+	<a href="#">Samples</a>
LM137H/NOPB	ACTIVE	TO	NDT	3	500	Green (RoHS & no Sb/Br)	AU	Level-1-NA-UNLIM	-55 to 150	LM137HP+	<a href="#">Samples</a>
LM337H	ACTIVE	TO	NDT	3	500	Green (RoHS & no Sb/Br)	AU	Level-1-NA-UNLIM	-40 to 125	LM337H	<a href="#">Samples</a>
LM337H/NOPB	ACTIVE	TO	NDT	3	500	Green (RoHS & no Sb/Br)	AU	Level-1-NA-UNLIM	-40 to 125	LM337H	<a href="#">Samples</a>
LM337IMP	NRND	SOT-223	DCY	4	1000	TBD	Call TI	Call TI	-40 to 125	N02A	
LM337IMP/NOPB	ACTIVE	SOT-223	DCY	4	1000	Green (RoHS & no Sb/Br)	CU SN	Level-1-260C-UNLIM	-40 to 125	N02A	<a href="#">Samples</a>
LM337IMPX	NRND	SOT-223	DCY	4	2000	TBD	Call TI	Call TI	-40 to 125	N02A	
LM337IMPX/NOPB	ACTIVE	SOT-223	DCY	4	2000	Green (RoHS & no Sb/Br)	CU SN	Level-1-260C-UNLIM	-40 to 125	N02A	<a href="#">Samples</a>
LM337T	NRND	TO-220	NDE	3	45	TBD	Call TI	Call TI	-40 to 125	LM337T P+	
LM337T/LF01	ACTIVE	TO-220	NDG	3	45	Pb-Free (RoHS Exempt)	CU SN	Level-3-245C-168 HR		LM337T P+	<a href="#">Samples</a>
LM337T/NOPB	ACTIVE	TO-220	NDE	3	45	Pb-Free (RoHS Exempt)	CU SN	Level-1-NA-UNLIM	-40 to 125	LM337T P+	<a href="#">Samples</a>

(1) The marketing status values are defined as follows:

**ACTIVE:** Product device recommended for new designs.

**LIFEBUY:** TI has announced that the device will be discontinued, and a lifetime-buy period is in effect.

**NRND:** Not recommended for new designs. Device is in production to support existing customers, but TI does not recommend using this part in a new design.

**PREVIEW:** Device has been announced but is not in production. Samples may or may not be available.

**OBSELETE:** TI has discontinued the production of the device.

(2) Eco Plan - The planned eco-friendly classification: Pb-Free (RoHS), Pb-Free (RoHS Exempt), or Green (RoHS & no Sb/Br) - please check <http://www.ti.com/productcontent> for the latest availability information and additional product content details.

**TBD:** The Pb-Free/Green conversion plan has not been defined.

**Pb-Free (RoHS):** TI's terms "Lead-Free" or "Pb-Free" mean semiconductor products that are compatible with the current RoHS requirements for all 6 substances, including the requirement that lead not exceed 0.1% by weight in homogeneous materials. Where designed to be soldered at high temperatures, TI Pb-Free products are suitable for use in specified lead-free processes.

**Pb-Free (RoHS Exempt):** This component has a RoHS exemption for either 1) lead-based flip-chip solder bumps used between the die and package, or 2) lead-based die adhesive used between the die and leadframe. The component is otherwise considered Pb-Free (RoHS compatible) as defined above.

**Green (RoHS & no Sb/Br):** TI defines "Green" to mean Pb-Free (RoHS compatible), and free of Bromine (Br) and Antimony (Sb) based flame retardants (Br or Sb do not exceed 0.1% by weight in homogeneous material)

- (3) MSL, Peak Temp. - The Moisture Sensitivity Level rating according to the JEDEC industry standard classifications, and peak solder temperature.
- (4) There may be additional marking, which relates to the logo, the lot trace code information, or the environmental category on the device.
- (5) Multiple Device Markings will be inside parentheses. Only one Device Marking contained in parentheses and separated by a "~" will appear on a device. If a line is indented then it is a continuation of the previous line and the two combined represent the entire Device Marking for that device.
- (6) Lead/Ball Finish - Orderable Devices may have multiple material finish options. Finish options are separated by a vertical ruled line. Lead/Ball Finish values may wrap to two lines if the finish value exceeds the maximum column width.

**Important Information and Disclaimer:**The information provided on this page represents TI's knowledge and belief as of the date that it is provided. TI bases its knowledge and belief on information provided by third parties, and makes no representation or warranty as to the accuracy of such information. Efforts are underway to better integrate information from third parties. TI has taken and continues to take reasonable steps to provide representative and accurate information but may not have conducted destructive testing or chemical analysis on incoming materials and chemicals. TI and TI suppliers consider certain information to be proprietary, and thus CAS numbers and other limited information may not be available for release.

In no event shall TI's liability arising out of such information exceed the total purchase price of the TI part(s) at issue in this document sold by TI to Customer on an annual basis.

**TAPE AND REEL INFORMATION**

**QUADRANT ASSIGNMENTS FOR PIN 1 ORIENTATION IN TAPE**

\*All dimensions are nominal

Device	Package Type	Package Drawing	Pins	SPQ	Reel Diameter (mm)	Reel Width W1 (mm)	A0 (mm)	B0 (mm)	K0 (mm)	P1 (mm)	W (mm)	Pin1 Quadrant
LM337IMP	SOT-223	DCY	4	1000	330.0	16.4	7.0	7.5	2.2	12.0	16.0	Q3
LM337IMP/NOPB	SOT-223	DCY	4	1000	330.0	16.4	7.0	7.5	2.2	12.0	16.0	Q3
LM337IMPX	SOT-223	DCY	4	2000	330.0	16.4	7.0	7.5	2.2	12.0	16.0	Q3
LM337IMPX/NOPB	SOT-223	DCY	4	2000	330.0	16.4	7.0	7.5	2.2	12.0	16.0	Q3

**TAPE AND REEL BOX DIMENSIONS**

\*All dimensions are nominal

Device	Package Type	Package Drawing	Pins	SPQ	Length (mm)	Width (mm)	Height (mm)
LM337IMP	SOT-223	DCY	4	1000	367.0	367.0	35.0
LM337IMP/NOPB	SOT-223	DCY	4	1000	367.0	367.0	35.0
LM337IMPX	SOT-223	DCY	4	2000	367.0	367.0	35.0
LM337IMPX/NOPB	SOT-223	DCY	4	2000	367.0	367.0	35.0

NDT0003A

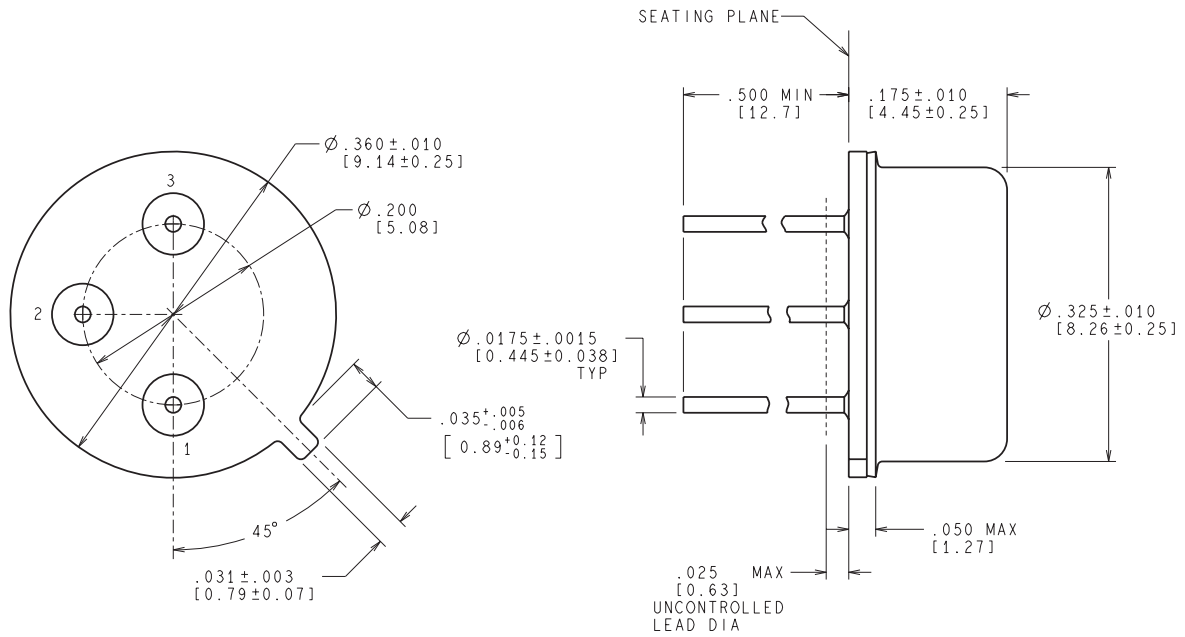

CONTROLLING DIMENSION IS INCH  
VALUES IN [ ] ARE MILLIMETERS

MIL-PRF-38535  
CONFIGURATION CONTROL

H03A (Rev D)

NDE0003B

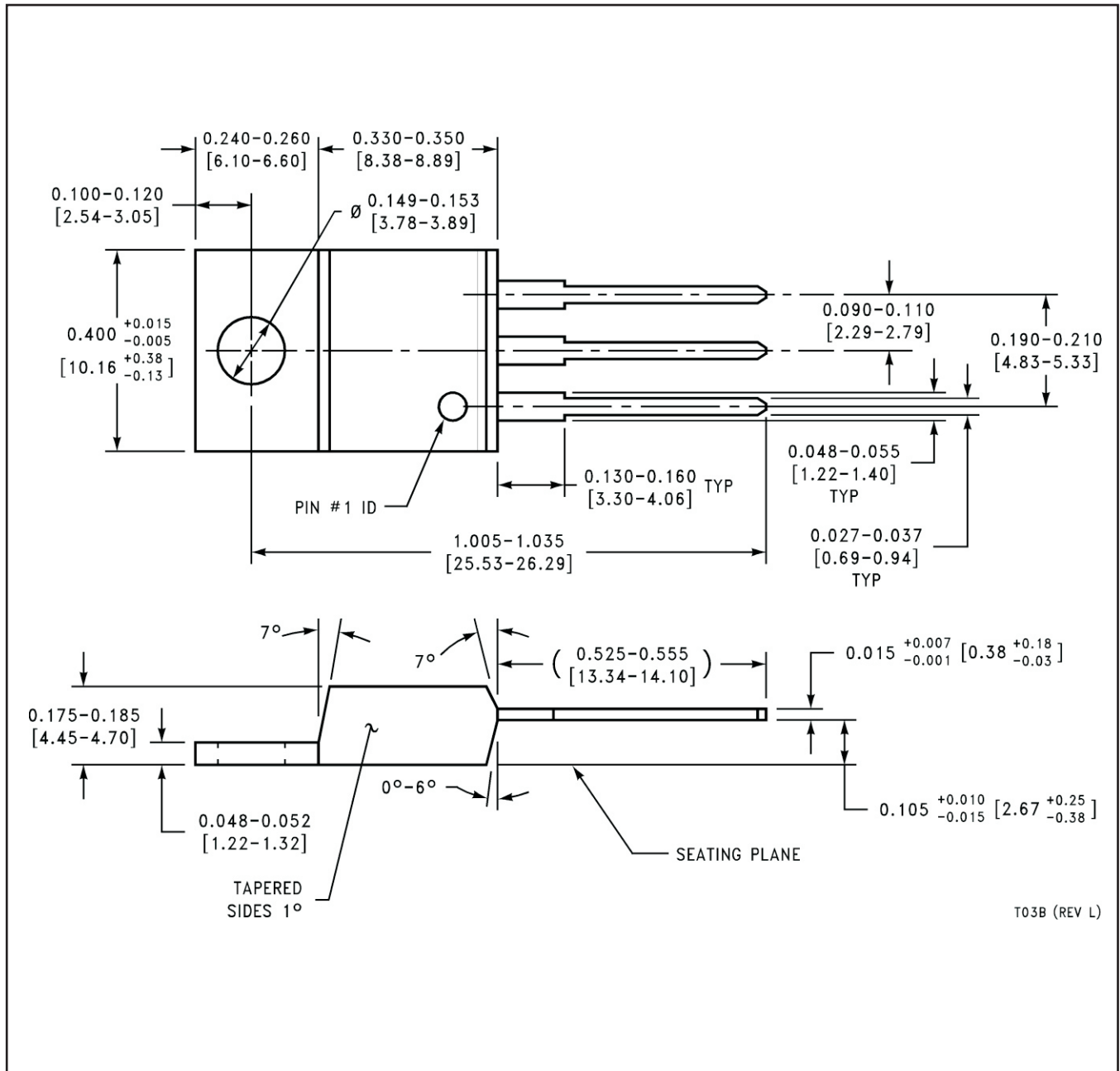

NDG0003F

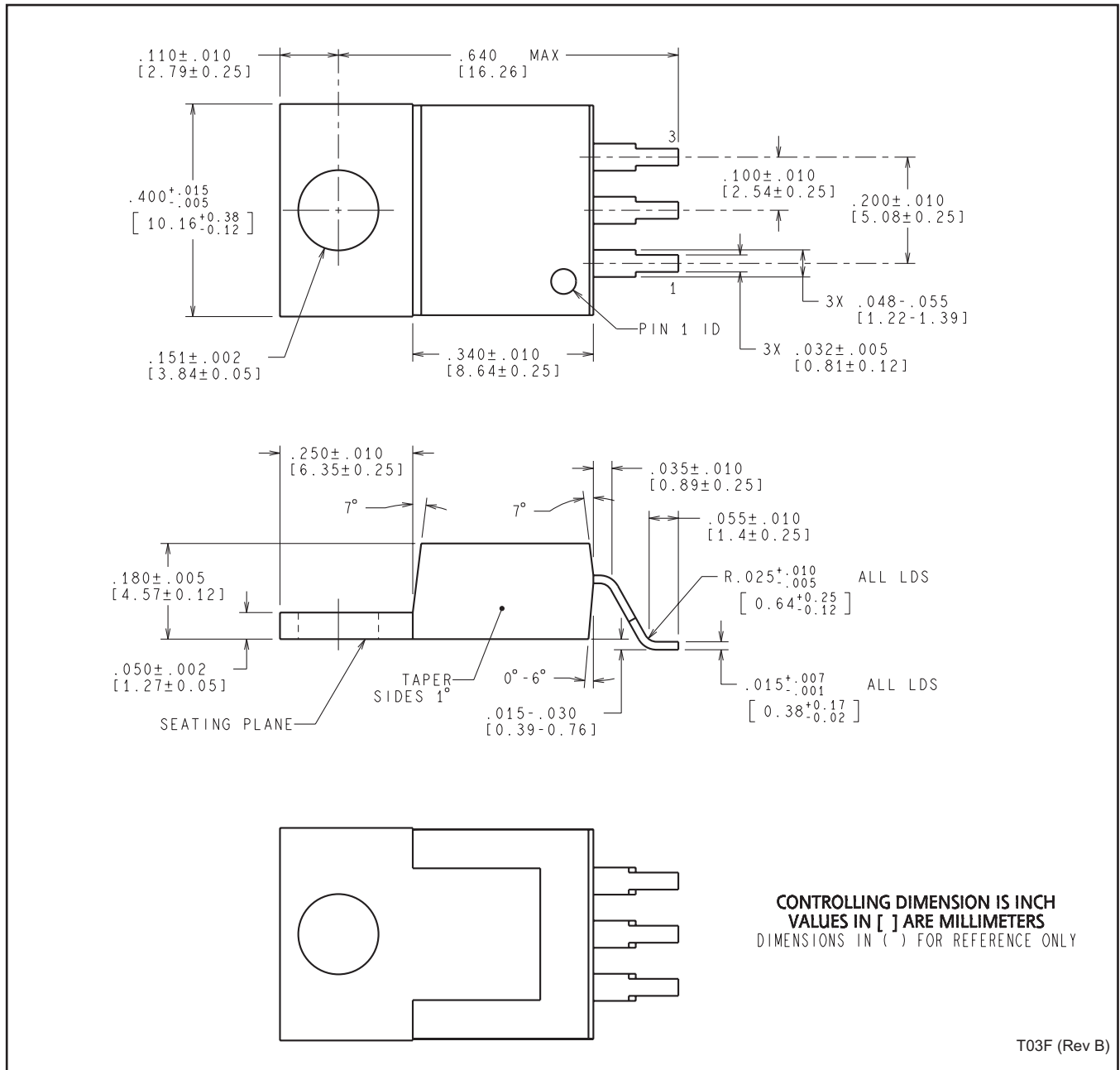

T03F (Rev B)

DCY (R-PDSO-G4)

PLASTIC SMALL-OUTLINE

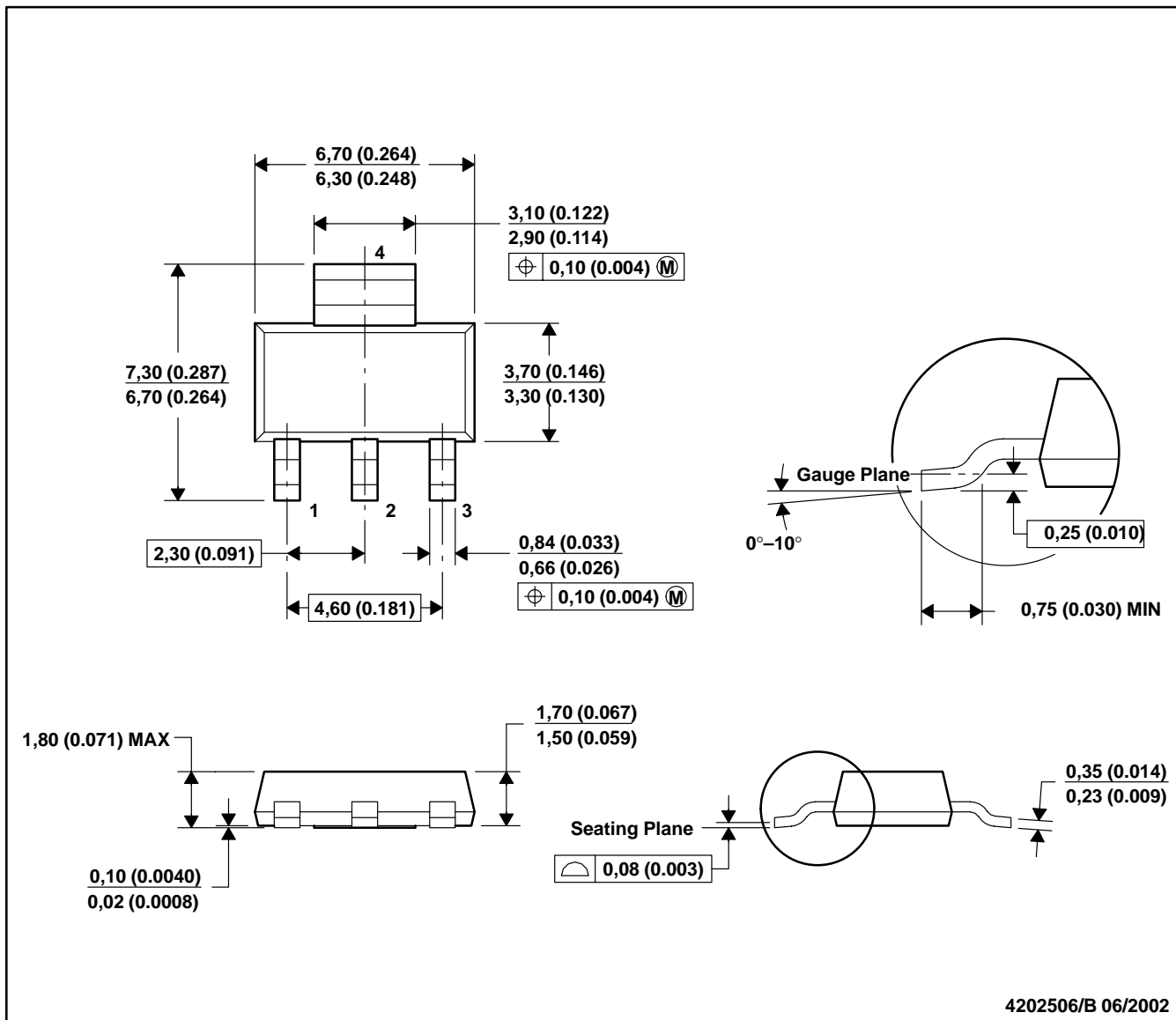

- NOTES: A. All linear dimensions are in millimeters (inches).  
 B. This drawing is subject to change without notice.  
 C. Body dimensions do not include mold flash or protrusion.  
 D. Falls within JEDEC TO-261 Variation AA.

## IMPORTANT NOTICE

Texas Instruments Incorporated and its subsidiaries (TI) reserve the right to make corrections, enhancements, improvements and other changes to its semiconductor products and services per JESD46, latest issue, and to discontinue any product or service per JESD48, latest issue. Buyers should obtain the latest relevant information before placing orders and should verify that such information is current and complete. All semiconductor products (also referred to herein as "components") are sold subject to TI's terms and conditions of sale supplied at the time of order acknowledgment.

TI warrants performance of its components to the specifications applicable at the time of sale, in accordance with the warranty in TI's terms and conditions of sale of semiconductor products. Testing and other quality control techniques are used to the extent TI deems necessary to support this warranty. Except where mandated by applicable law, testing of all parameters of each component is not necessarily performed.

TI assumes no liability for applications assistance or the design of Buyers' products. Buyers are responsible for their products and applications using TI components. To minimize the risks associated with Buyers' products and applications, Buyers should provide adequate design and operating safeguards.

TI does not warrant or represent that any license, either express or implied, is granted under any patent right, copyright, mask work right, or other intellectual property right relating to any combination, machine, or process in which TI components or services are used. Information published by TI regarding third-party products or services does not constitute a license to use such products or services or a warranty or endorsement thereof. Use of such information may require a license from a third party under the patents or other intellectual property of the third party, or a license from TI under the patents or other intellectual property of TI.

Reproduction of significant portions of TI information in TI data books or data sheets is permissible only if reproduction is without alteration and is accompanied by all associated warranties, conditions, limitations, and notices. TI is not responsible or liable for such altered documentation. Information of third parties may be subject to additional restrictions.

Resale of TI components or services with statements different from or beyond the parameters stated by TI for that component or service voids all express and any implied warranties for the associated TI component or service and is an unfair and deceptive business practice. TI is not responsible or liable for any such statements.

Buyer acknowledges and agrees that it is solely responsible for compliance with all legal, regulatory and safety-related requirements concerning its products, and any use of TI components in its applications, notwithstanding any applications-related information or support that may be provided by TI. Buyer represents and agrees that it has all the necessary expertise to create and implement safeguards which anticipate dangerous consequences of failures, monitor failures and their consequences, lessen the likelihood of failures that might cause harm and take appropriate remedial actions. Buyer will fully indemnify TI and its representatives against any damages arising out of the use of any TI components in safety-critical applications.

In some cases, TI components may be promoted specifically to facilitate safety-related applications. With such components, TI's goal is to help enable customers to design and create their own end-product solutions that meet applicable functional safety standards and requirements. Nonetheless, such components are subject to these terms.

No TI components are authorized for use in FDA Class III (or similar life-critical medical equipment) unless authorized officers of the parties have executed a special agreement specifically governing such use.

Only those TI components which TI has specifically designated as military grade or "enhanced plastic" are designed and intended for use in military/aerospace applications or environments. Buyer acknowledges and agrees that any military or aerospace use of TI components which have **not** been so designated is solely at the Buyer's risk, and that Buyer is solely responsible for compliance with all legal and regulatory requirements in connection with such use.

TI has specifically designated certain components as meeting ISO/TS16949 requirements, mainly for automotive use. In any case of use of non-designated products, TI will not be responsible for any failure to meet ISO/TS16949.

### Products

Audio	<a href="http://www.ti.com/audio">www.ti.com/audio</a>
Amplifiers	<a href="http://amplifier.ti.com">amplifier.ti.com</a>
Data Converters	<a href="http://dataconverter.ti.com">dataconverter.ti.com</a>
DLP® Products	<a href="http://www.dlp.com">www.dlp.com</a>
DSP	<a href="http://dsp.ti.com">dsp.ti.com</a>
Clocks and Timers	<a href="http://www.ti.com/clocks">www.ti.com/clocks</a>
Interface	<a href="http://interface.ti.com">interface.ti.com</a>
Logic	<a href="http://logic.ti.com">logic.ti.com</a>
Power Mgmt	<a href="http://power.ti.com">power.ti.com</a>
Microcontrollers	<a href="http://microcontroller.ti.com">microcontroller.ti.com</a>
RFID	<a href="http://www.ti-rfid.com">www.ti-rfid.com</a>
OMAP Applications Processors	<a href="http://www.ti.com/omap">www.ti.com/omap</a>
Wireless Connectivity	<a href="http://www.ti.com/wirelessconnectivity">www.ti.com/wirelessconnectivity</a>

### Applications

Automotive and Transportation	<a href="http://www.ti.com/automotive">www.ti.com/automotive</a>
Communications and Telecom	<a href="http://www.ti.com/communications">www.ti.com/communications</a>
Computers and Peripherals	<a href="http://www.ti.com/computers">www.ti.com/computers</a>
Consumer Electronics	<a href="http://www.ti.com/consumer-apps">www.ti.com/consumer-apps</a>
Energy and Lighting	<a href="http://www.ti.com/energy">www.ti.com/energy</a>
Industrial	<a href="http://www.ti.com/industrial">www.ti.com/industrial</a>
Medical	<a href="http://www.ti.com/medical">www.ti.com/medical</a>
Security	<a href="http://www.ti.com/security">www.ti.com/security</a>
Space, Avionics and Defense	<a href="http://www.ti.com/space-avionics-defense">www.ti.com/space-avionics-defense</a>
Video and Imaging	<a href="http://www.ti.com/video">www.ti.com/video</a>

### TI E2E Community

[e2e.ti.com](http://e2e.ti.com)