

## LM146/LM346 Programmable Quad Operational Amplifiers

Check for Samples: [LM146](#), [LM346](#)

### FEATURES

- ( $I_{SET}=10\ \mu\text{A}$ )
- Programmable Electrical Characteristics
- Battery-Powered Operation
- Low Supply Current: 350  $\mu\text{A}/\text{Amplifier}$
- Ensured Gain Bandwidth Product: 0.8 MHz Min
- Large DC Voltage Gain: 120 dB
- Low Noise Voltage: 28  $\text{nV}/\sqrt{\text{Hz}}$
- Wide Power Supply Range:  $\pm 1.5\text{V}$  to  $\pm 22\text{V}$
- Class AB Output Stage—No Crossover Distortion
- Ideal Pin Out for Biquad Active Filters
- Input Bias Currents are Temperature Compensated

### DESCRIPTION

The LM146 series of quad op amps consists of four independent, high gain, internally compensated, low power, programmable amplifiers. Two external resistors ( $R_{SET}$ ) allow the user to program the gain bandwidth product, slew rate, supply current, input bias current, input offset current and input noise. For example, the user can trade-off supply current for bandwidth or optimize noise figure for a given source resistance. In a similar way, other amplifier characteristics can be tailored to the application. Except for the two programming pins at the end of the package, the LM146 pin-out is the same as the LM124 and LM148.

### Connection Diagram

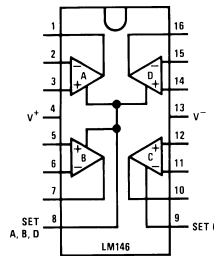

**Figure 1. Dual-In-Line Package - Top View**  
See Package Number NFE0016A, D0016A or N16A

### PROGRAMMING EQUATIONS

**Total Supply Current** = 1.4 mA ( $I_{SET}/10\ \mu\text{A}$ )

**Gain Bandwidth Product** = 1 MHz ( $I_{SET}/10\ \mu\text{A}$ )

**Slew Rate** = 0.4V/ $\mu\text{s}$  ( $I_{SET}/10\ \mu\text{A}$ )

**Input Bias Current**  $\approx$  50 nA ( $I_{SET}/10\ \mu\text{A}$ )

$I_{SET}$  = Current into pin 8, pin 9 (see [Schematic Diagram](#))

$$I_{SET} = \frac{V^+ - V^- - 0.6\text{V}}{R_{SET}}$$

(1)



Please be aware that an important notice concerning availability, standard warranty, and use in critical applications of Texas Instruments semiconductor products and disclaimers thereto appears at the end of this data sheet.

All trademarks are the property of their respective owners.

### Capacitorless Active Filters (Basic Circuit)

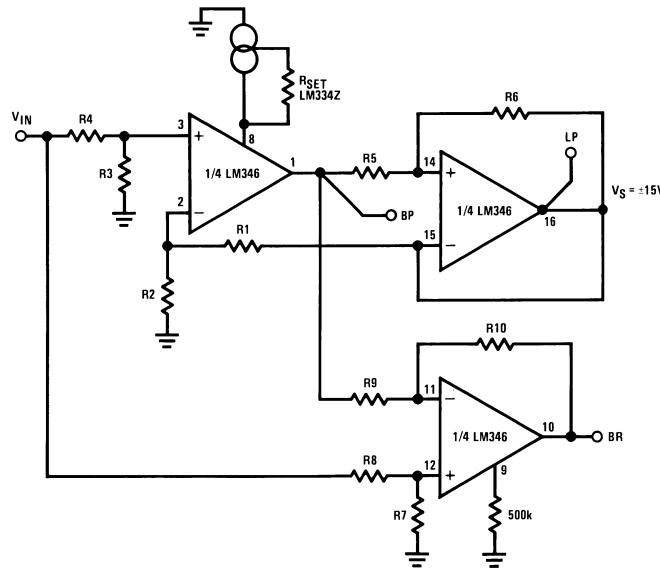

These devices have limited built-in ESD protection. The leads should be shorted together or the device placed in conductive foam during storage or handling to prevent electrostatic damage to the MOS gates.

### ABSOLUTE MAXIMUM RATINGS (1)(2)(3)

			LM146	LM346
Supply Voltage			±22V	±18V
Differential Input Voltage <sup>(2)</sup>			±30V	±30V
CM Input Voltage <sup>(2)</sup>			±15V	±15V
Power Dissipation <sup>(4)</sup>			900 mW	500 mW
Output Short-Circuit Duration <sup>(5)</sup>			Continuous	Continuous
Operating Temperature Range			-55°C to +125°C	0°C to +70°C
Maximum Junction Temperature			150°C	100°C
Storage Temperature Range			-65°C to +150°C	-65°C to +150°C
Lead Temperature (Soldering, 10 seconds)			260°C	260°C
Thermal Resistance ( $\theta_{jA}$ ) <sup>(4)</sup>	CDIP (NFE)	Pd	900 mW	900 mW
		$\theta_{jA}$	100°C/W	100°C/W
	SOIC (D)	$\theta_{jA}$		115°C/W
	PDIP (N)	Pd		500 mW
$\theta_{jA}$			90°C/W	
Soldering Information	Dual-In-Line Package	Soldering (10 seconds)	+260°C	+260°C
	Small Outline Package	Vapor Phase (60 seconds)	+215°C	+215°C
		Infrared (15 seconds)	+220°C	+220°C

ESD rating is to be determined.

- Refer to RETS146X for LM146J military specifications.
- For supply voltages less than ±15V, the absolute maximum input voltage is equal to the supply voltage.
- If Military/Aerospace specified devices are required, please contact the Texas Instruments Sales Office/ Distributors for availability and specifications.
- The maximum power dissipation for these devices must be derated at elevated temperatures and is dictated by  $T_{jMAX}$ ,  $\theta_{jA}$ , and the ambient temperature,  $T_A$ . The maximum available power dissipation at any temperature is  $P_d = (T_{jMAX} - T_A) / \theta_{jA}$  or the 25°C  $P_{dMAX}$ , whichever is less.
- Any of the amplifier outputs can be shorted to ground indefinitely; however, more than one should not be simultaneously shorted as the maximum junction temperature will be exceeded.

## DC ELECTRICAL CHARACTERISTICS

 $(V_S = \pm 15V, I_{SET} = 10 \mu A)^{(1)}$ 

Parameter	Conditions	LM146			LM346			Units
		Min	Typ	Max	Min	Typ	Max	
Input Offset Voltage	$V_{CM}=0V, R_S \leq 50\Omega, T_A=25^\circ C$		0.5	5		0.5	6	mV
Input Offset Current	$V_{CM}=0V, T_A=25^\circ C$		2	20		2	100	nA
Input Bias Current	$V_{CM}=0V, T_A=25^\circ C$		50	100		50	250	nA
Supply Current (4 Op Amps)	$T_A=25^\circ C$		1.4	2.0		1.4	2.5	mA
Large Signal Voltage Gain	$R_L=10 \text{ k}\Omega, \Delta V_{OUT}=\pm 10V, T_A=25^\circ C$	100	1000		50	1000		V/mV
Input CM Range	$T_A=25^\circ C$	$\pm 13.5$	$\pm 14$		$\pm 13.5$	$\pm 14$		V
CM Rejection Ratio	$R_S \leq 10 \text{ k}\Omega, T_A=25^\circ C$	80	100		70	100		dB
Power Supply Rejection Ratio	$R_S \leq 10 \text{ k}\Omega, T_A=25^\circ C, V_S = \pm 5 \text{ to } \pm 15V$	80	100		74	100		dB
Output Voltage Swing	$R_L \geq 10 \text{ k}\Omega, T_A=25^\circ C$	$\pm 12$	$\pm 14$		$\pm 12$	$\pm 14$		V
Short-Circuit	$T_A=25^\circ C$	5	20	35	5	20	35	mA
Gain Bandwidth Product	$T_A=25^\circ C$	0.8	1.2		0.5	1.2		MHz
Phase Margin	$T_A=25^\circ C$		60			60		Deg
Slew Rate	$T_A=25^\circ C$		0.4			0.4		V/ $\mu s$
Input Noise Voltage	$f=1 \text{ kHz}, T_A=25^\circ C$		28			28		8 nV/ $\sqrt{Hz}$
Channel Separation	$R_L=10 \text{ k}\Omega, \Delta V_{OUT}=0V \text{ to } \pm 12V, T_A=25^\circ C$		120			120		dB
Input Resistance	$T_A=25^\circ C$		1.0			1.0		M $\Omega$
Input Capacitance	$T_A=25^\circ C$		2.0			2.0		pF
Input Offset Voltage	$V_{CM}=0V, R_S \leq 50\Omega$		0.5	6		0.5	7.5	mV
Input Offset Current	$V_{CM}=0V$		2	25		2	100	nA
Input Bias Current	$V_{CM}=0V$		50	100		50	250	nA
Supply Current (4 Op Amps)			1.7	2.2		1.7	2.5	mA
Large Signal Voltage Gain	$R_L=10 \text{ k}\Omega, \Delta V_{OUT}=\pm 10V$	50	1000		25	1000		V/mV
Input CM Range		$\pm 13.5$	$\pm 14$		$\pm 13.5$	$\pm 14$		V
CM Rejection Ratio	$R_S \leq 50\Omega$	70	100		70	100		dB
Power Supply Rejection Ratio	$R_S \leq 50\Omega, V_S = \pm 5V \text{ to } \pm 15V$	76	100		74	100		dB
Output Voltage Swing	$R_L \geq 10 \text{ k}\Omega$	$\pm 12$	$\pm 14$		$\pm 12$	$\pm 14$		V

(1) These specifications apply over the absolute maximum operating temperature range unless otherwise noted.

## DC ELECTRICAL CHARACTERISTIC

 $(V_S = \pm 15V, I_{SET} = 10 \mu A)$ 

Parameter	Conditions	LM146			LM346			Units
		Min	Typ	Max	Min	Typ	Max	
Input Offset Voltage	$V_{CM}=0V, R_S \leq 50\Omega, T_A=25^\circ C$		0.5	5		0.5	7	mV
Input Bias Current	$V_{CM}=0V, T_A=25^\circ C$		7.5	20		7.5	100	nA
Supply Current (4 Op Amps)	$T_A=25^\circ C$		140	250		140	300	$\mu A$
Gain Bandwidth Product	$T_A=25^\circ C$	80	100		50	100		kHz

**DC ELECTRICAL CHARACTERISTICS** $(V_S = \pm 1.5V, I_{SET} = 10 \mu A)$ 

Parameter	Conditions	LM146			LM346			Units
		Min	Typ	Max	Min	Typ	Max	
Input Offset Voltage	$V_{CM} = 0V, R_S \leq 50\Omega, T_A = 25^\circ C$		0.5	5		0.5	7	mV
Input CM Range	$T_A = 25^\circ C$	$\pm 0.7$			$\pm 0.7$			V
CM Rejection Ratio	$R_S \leq 50\Omega, T_A = 25^\circ C$		80			80		dB
Output Voltage Swing	$R_L \geq 10 k\Omega, T_A = 25^\circ C$	$\pm 0.6$			$\pm 0.6$			V

TYPICAL PERFORMANCE CHARACTERISTICS

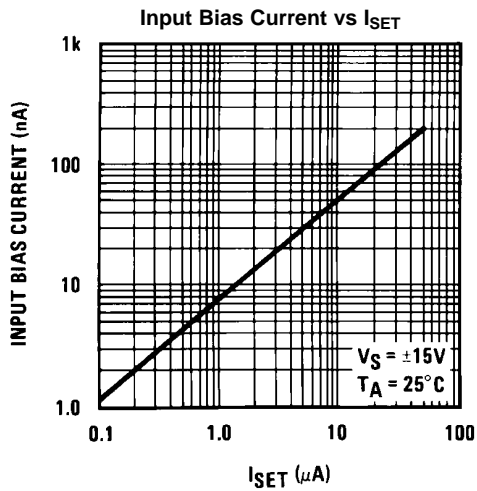

Figure 2.

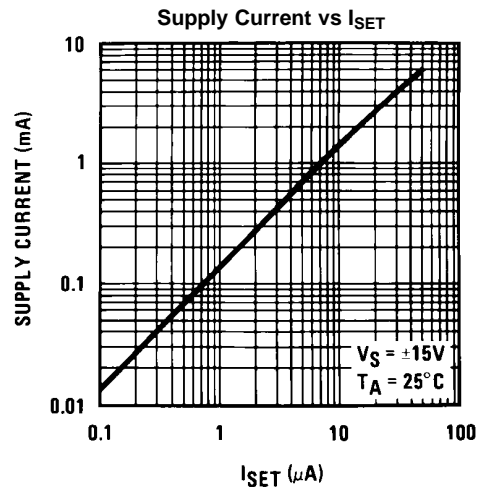

Figure 3.

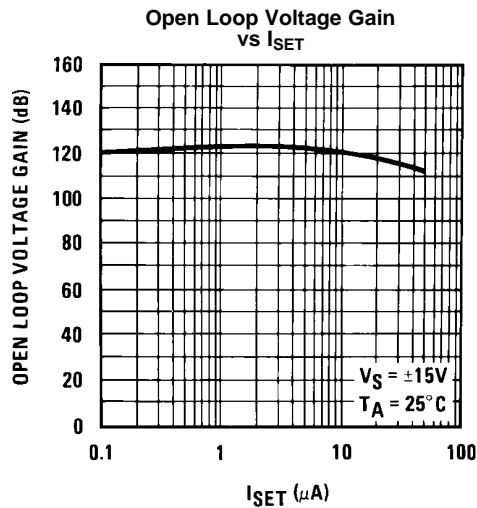

Figure 4.

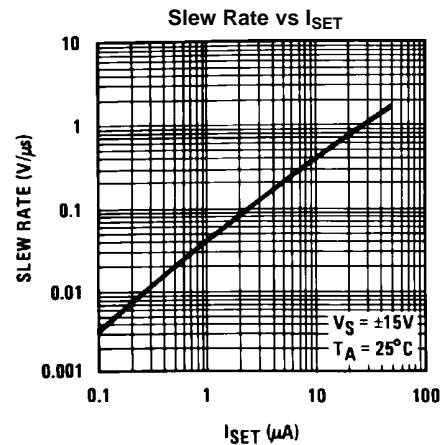

Figure 5.

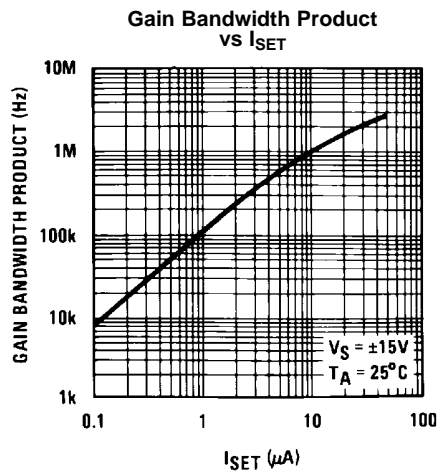

Figure 6.

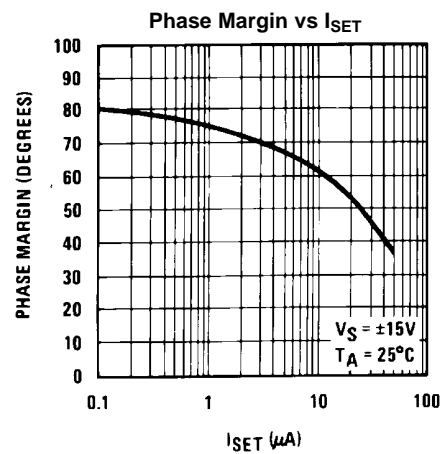
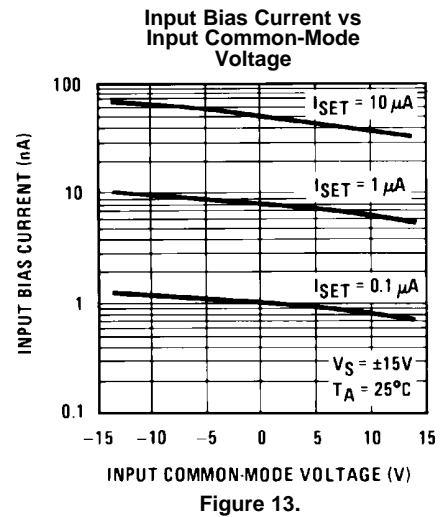
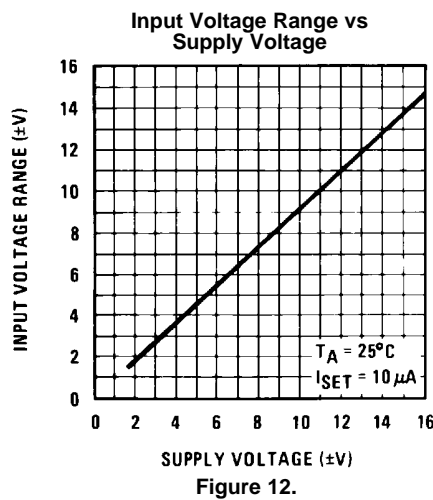
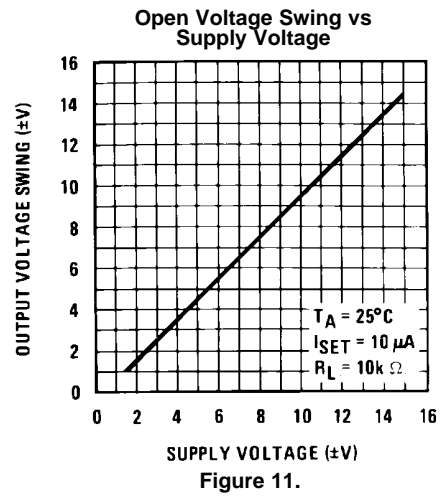
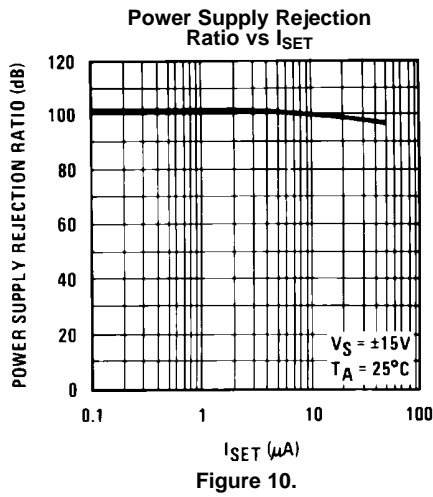
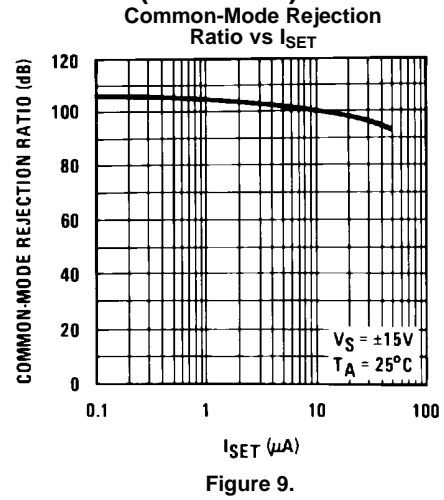
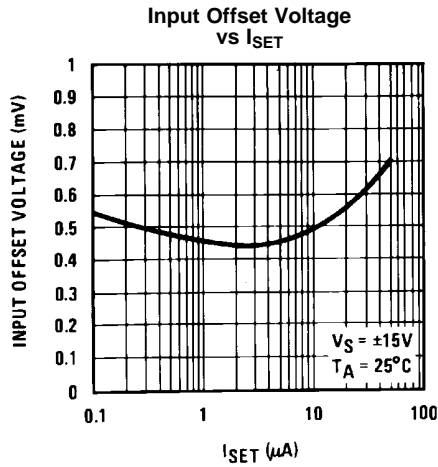
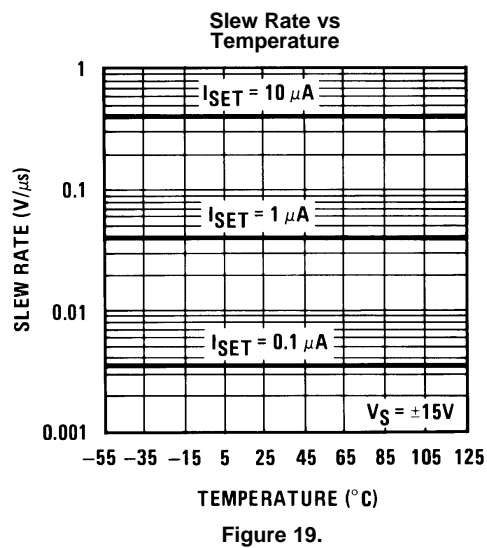
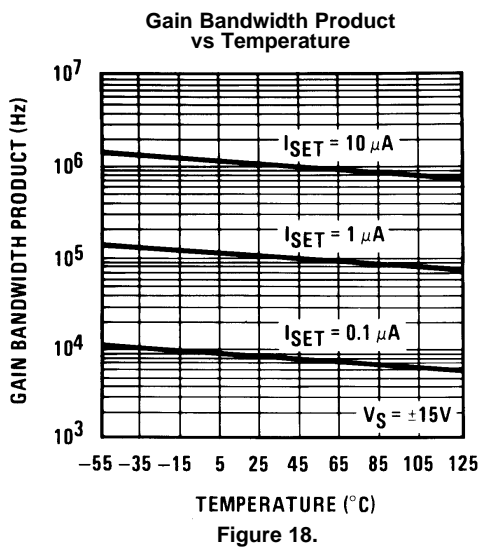
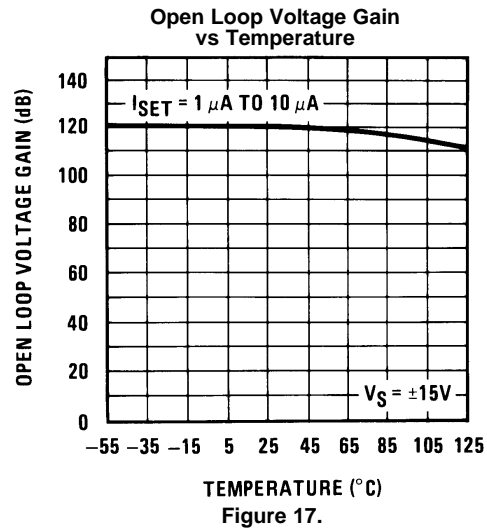
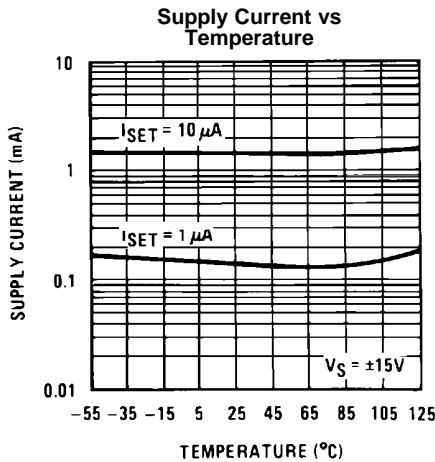
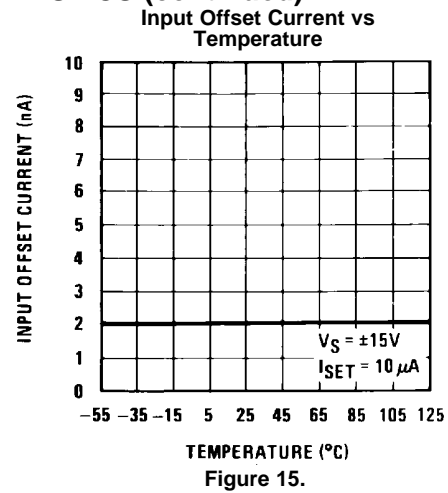
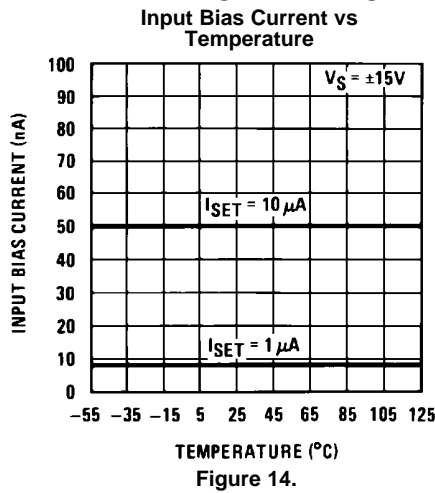

Figure 7.

**TYPICAL PERFORMANCE CHARACTERISTICS (continued)**



**TYPICAL PERFORMANCE CHARACTERISTICS (continued)**



**TYPICAL PERFORMANCE CHARACTERISTICS (continued)**

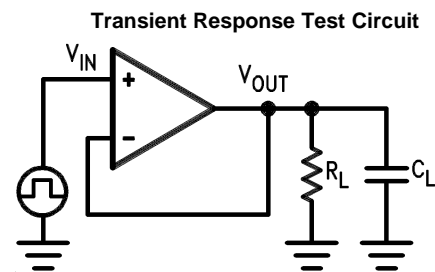
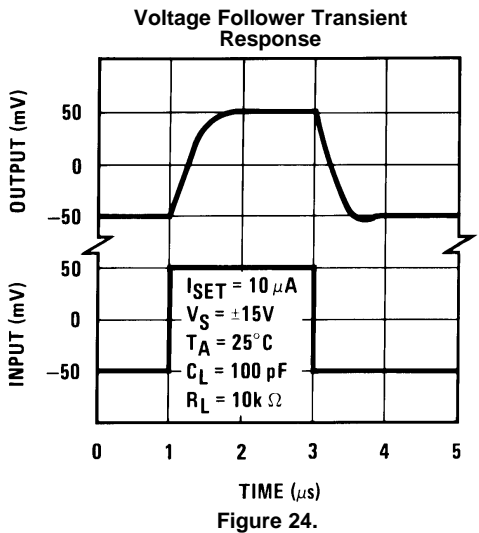
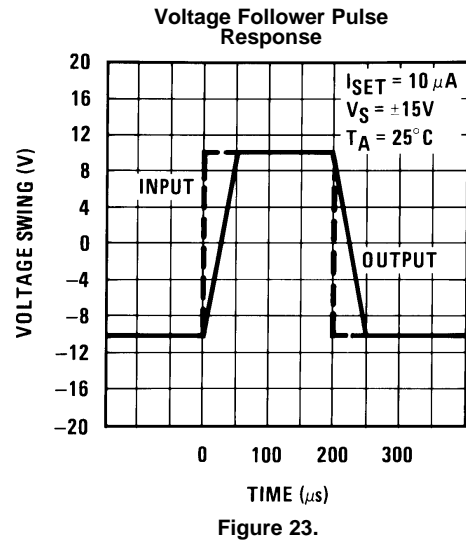
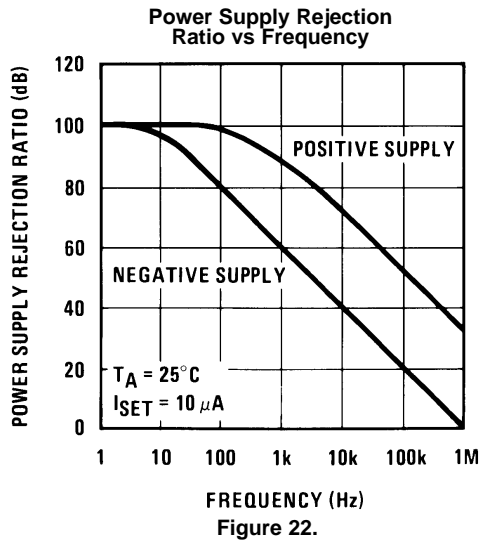
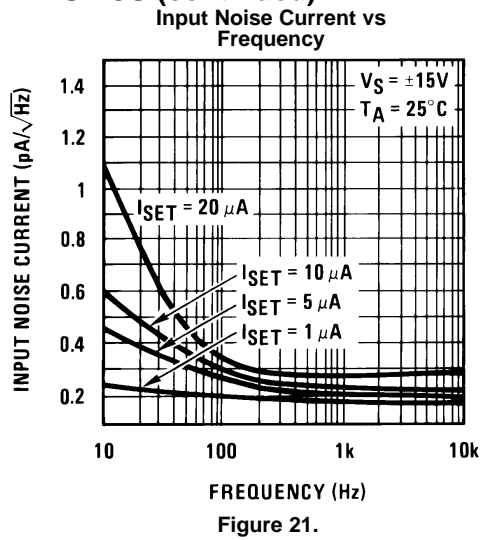
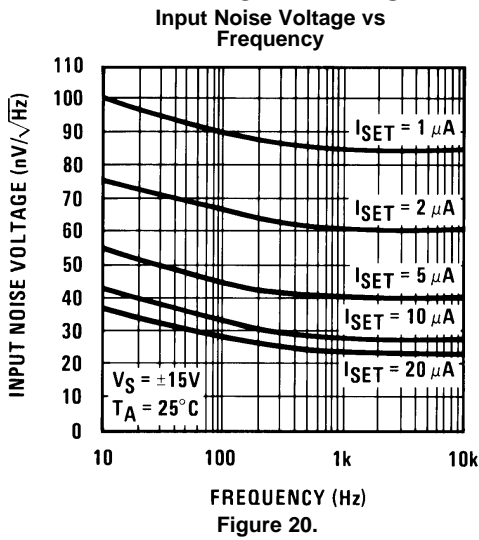

Figure 25.

## APPLICATION HINTS

Avoid reversing the power supply polarity; the device will fail.

### COMMON-MODE INPUT VOLTAGE

The negative common-mode voltage limit is one diode drop above the negative supply voltage. Exceeding this limit on either input will result in an output phase reversal. The positive common-mode limit is typically 1V below the positive supply voltage. No output phase reversal will occur if this limit is exceeded by either input.

### OUTPUT VOLTAGE SWING VS $I_{SET}$

For a desired output voltage swing the value of the minimum load depends on the positive and negative output current capability of the op amp. The maximum available positive output current, ( $I_{CL+}$ ), of the device increases with  $I_{SET}$  whereas the negative output current ( $I_{CL-}$ ) is independent of  $I_{SET}$ . Figure 26 illustrates the above.

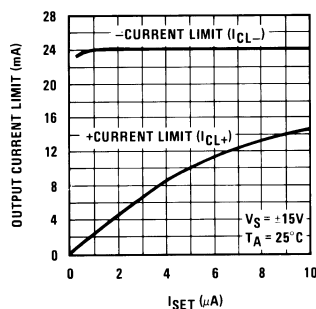

Figure 26. Output Current Limit vs  $I_{SET}$

### INPUT CAPACITANCE

The input capacitance,  $C_{IN}$ , of the LM146 is approximately 2 pF; any stray capacitance,  $C_S$ , (due to external circuit layout) will add to  $C_{IN}$ . When resistive or active feedback is applied, an additional pole is added to the open loop frequency response of the device. For instance with resistive feedback (Figure 27), this pole occurs at  $\frac{1}{2}\pi (R1||R2) (C_{IN} + C_S)$ . Make sure that this pole occurs at least 2 octaves beyond the expected -3 dB frequency corner of the closed loop gain of the amplifier; if not, place a lead capacitor in the feedback such that the time constant of this capacitor and the resistance it parallels is equal to the  $R_1(C_S + C_{IN})$ , where  $R_1$  is the input resistance of the circuit.

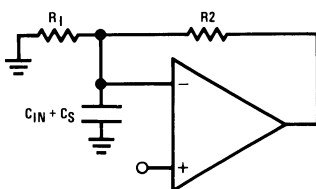

Figure 27. Resistive Feedback Circuit Example

### TEMPERATURE EFFECT ON THE GBW

The GBW (gain bandwidth product), of the LM146 is directly proportional to  $I_{SET}$  and inversely proportional to the absolute temperature. When using resistors to set the bias current,  $I_{SET}$ , of the device, the GBW product will decrease with increasing temperature. Compensation can be provided by creating an  $I_{SET}$  current directly proportional to temperature (see Typical Applications).

### ISOLATION BETWEEN AMPLIFIERS

The LM146 die is isothermally laid out such that crosstalk between all 4 amplifiers is in excess of -105 dB (DC). Optimum isolation (better than -110 dB) occurs between amplifiers A and D, B and C; that is, if amplifier A dissipates power on its output stage, amplifier D is the one which will be affected the least, and vice versa. Same argument holds for amplifiers B and C.

### LM146 TYPICAL PERFORMANCE SUMMARY

The LM146 typical behaviour is shown in Figure 28. The device is fully predictable. As the set current,  $I_{SET}$ , increases, the speed, the bias current, and the supply current increase while the noise power decreases proportionally and the  $V_{OS}$  remains constant. The usable GBW range of the op amp is 10 kHz to 3.5–4 MHz.

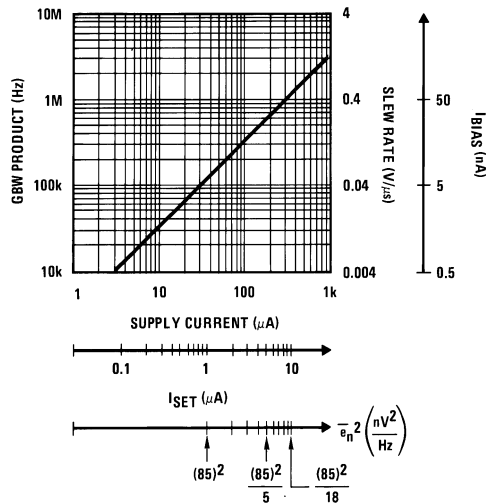

Figure 28. LM146 Typical Characteristics

**Low Power Supply Operation:** The quad op amp operates down to  $\pm 1.3V$  supply. Also, since the internal circuitry is biased through programmable current sources, no degradation of the device speed will occur.

### SPEED VS POWER CONSUMPTION

LM146 vs LM4250 (single programmable). Through Figure 29, we observe that the LM146's power consumption has been optimized for GBW products above 200 kHz, whereas the LM4250 will reach a GBW of no more than 300 kHz. For GBW products below 200 kHz, the LM4250 will consume less power.

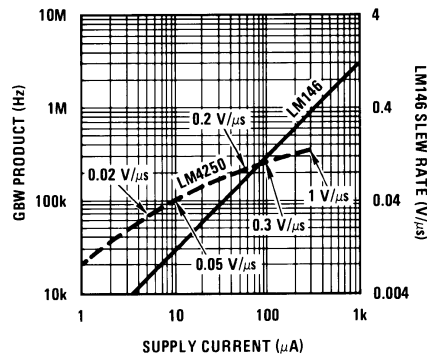
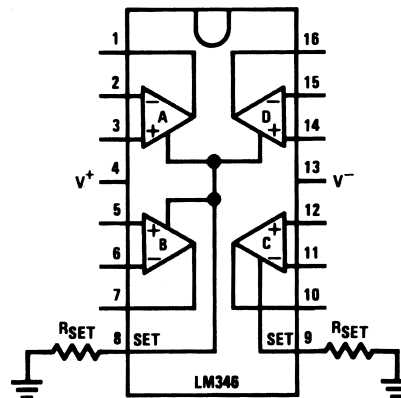

Figure 29. LM146 vs LM4250

Typical Applications



$$I_{SET} \cong \frac{|V^-| - 0.6V}{R_{SET}}$$

Figure 30. Dual Supply or Negative Supply Biasing

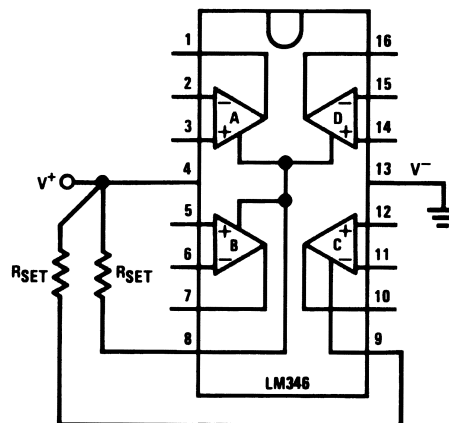

$$I_{SET} \cong \frac{V^+ - 0.6V}{R_{SET}}$$

Figure 31. Single (Positive) Supply Biasing

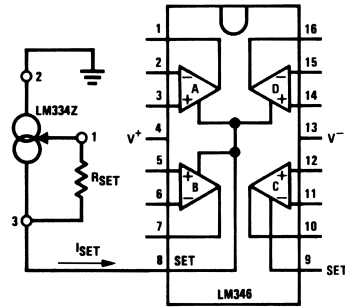

$$I_{SET} = \frac{67.7 \text{ mV}}{R_{SET}}$$

- The LM334 provides an  $I_{SET}$  directly proportional to absolute temperature. This cancels the slight GBW product Temperature coefficient of the LM346.

**Figure 32. Current Source Biasing with Temperature Compensation**

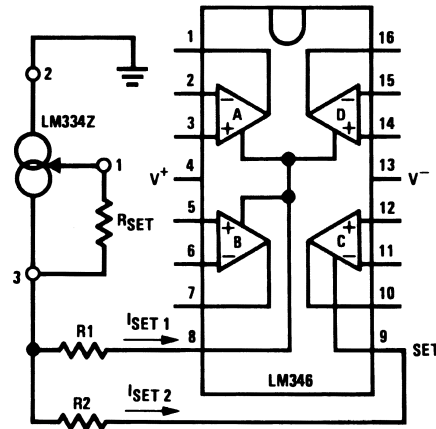

$$\frac{I_{SET1}}{I_{SET2}} = \frac{R2}{R1}, I_{SET1} + I_{SET2} = \frac{67.7 \text{ mV}}{R_{SET}}$$

- For  $I_{SET1} = I_{SET2}$  resistors R1 and R2 are not required if a slight error between the 2 set currents can be tolerated. If not, then use  $R1 = R2$  to create a 100 mV drop across these resistors.

**Figure 33. Biasing all 4 Amplifiers with Single Current Source**

Active Filters Applications

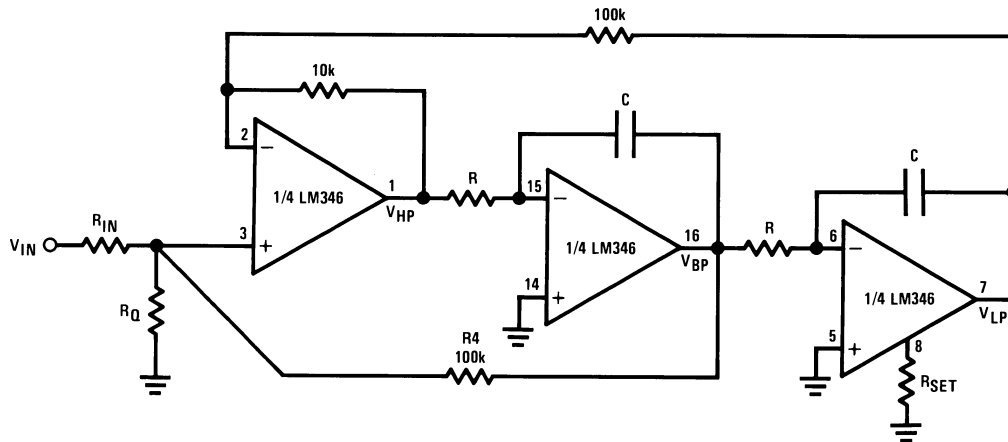

Figure 34. Basic (Non-Inverting “State Variable”) Active Filter Building Block

- The LM146 quad programmable op amp is especially suited for active filters because of their adequate GBW product and low power consumption.

**Circuit synthesis equations** (for circuit analysis equations, consult with the LM148 data sheet).

Need to know desired:  $f_o$  = center frequency measured at the BP output

$Q_o$  = quality factor measured at the BP output

$H_o$  = gain at the output of interest (BP or HP or LP or all of them)

- Relation between different gains:  $H_o(BP) = 0.316 \times Q_o \times H_o(LP)$ ;  $H_o(LP) = 10 \times H_o(HP)$

- $R \times C = \frac{5.033 \times 10^{-2}}{f_o}$  (sec)

- For BP output:  $R_Q = \left( \frac{3.478 Q_o - H_o(BP)}{10^5} - \frac{H_o(BP)}{10^5 \times 3.748 \times Q_o} \right)^{-1}$ ;  $R_{IN} = \frac{\left( \frac{3.478 Q_o - 1}{H_o(BP)} \right)}{\frac{1}{RQ} + 10^{-5}}$

- For HP output:  $R_Q = \frac{1.1 \times 10^5}{3.478 Q_o (1.1 - H_o(HP)) - H_o(HP)}$ ;  $R_{IN} = \frac{\frac{1.1}{H_o(HP)} - 1}{\frac{1}{RQ} + 10^{-5}}$

- For LP output:  $R_Q = \frac{11 \times 10^5}{3.478 Q_o (11 - H_o(LP)) - H_o(LP)}$ ;  $R_{IN} = \frac{\frac{11}{H_o(LP)} - 1}{\frac{1}{RQ} + 10^{-5}}$

- For BR (notch) output: Use the 4th amplifier of the LM146 to sum the LP and HP outputs of the basic filter.

**Note.** All resistor values are given in ohms.

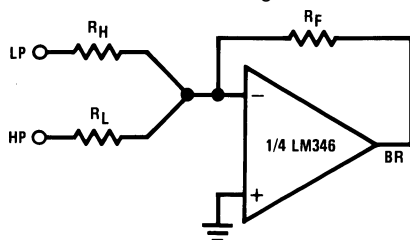

$$\sqrt{\frac{R_H}{R_L}} = 0.316 \frac{f_{notch}}{f_o}$$

Determine  $R_F$  according to the desired gains:  $H_o(BR) \Big|_{f << f_{notch}} = \frac{R_F}{R_L} H_o(LP)$ ,  $H_o(BR) \Big|_{f >> f_{notch}} = \frac{R_F}{R_H} H_o(HP)$

- **Where to use amplifier C:** Examine the above gain relations and determine the dynamics of the filter. Do not allow slew rate limiting in any output ( $V_{HP}$ ,  $V_{BP}$ ,  $V_{LP}$ ), that is:

$$V_{IN(peak)} < 63.66 \times 10^3 \times \frac{I_{SET}}{10 \mu A} \times \frac{1}{f_o \times H_o} \text{ (Volts)}$$

If necessary, use amplifier C, biased at higher  $I_{SET}$ , where you get the largest output swing.

**Deviation from Theoretical Predictions:** Due to the finite GBW products of the op amps the  $f_o$ ,  $Q_o$  will be slightly different from the theoretical predictions.

$$f_{real} \approx \frac{f_o}{1 + \frac{2 f_o}{GBW}}, Q_{real} \approx \frac{Q_o}{1 - \frac{3.2 f_o \times Q_o}{GBW}}$$

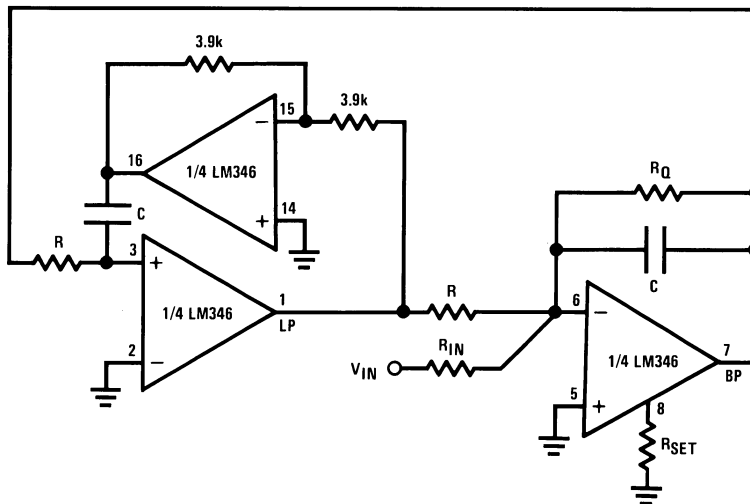

- If resistive biasing is used to set the LM346 performance, the  $Q_o$  of this filter building block is nearly insensitive to the op amp's GBW product temperature drift; it has also better noise performance than the state variable filter.

Figure 35. A Simple-to-Design BP, LP Filter Building Block

**Circuit Synthesis Equations**

$$H_o(BP) = Q_o H_o(LP); R \times C = \frac{0.159}{f_o}; R_Q = Q_o \times R; R_{IN} = \frac{R_Q}{H_o(BP)} = \frac{R}{H_o(LP)}$$

- For the eventual use of amplifier C, see comments above. (2)

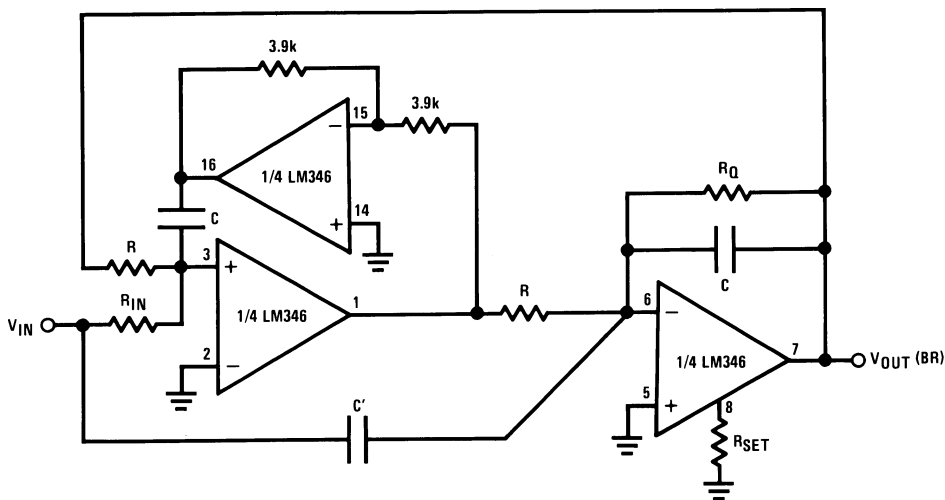

Figure 36. A 3-Amplifier Notch Filter (or Elliptic Filter Building Block)

### Circuit Synthesis Equations

$$R \times C = \frac{0.159}{f_o}; R_o = Q_o \times R; R_{IN} = \frac{0.159 \times f_o}{C' \times f_{notch}^2}$$

$$H_o(BR)|_{f \ll f_{notch}} = \frac{R}{R_{IN}} \quad H_o(BR)|_{f \gg f_{notch}} = \frac{C'}{C}$$

•For nothing but a notch output:  $R_{IN}=R, C'=C$ .

(3)

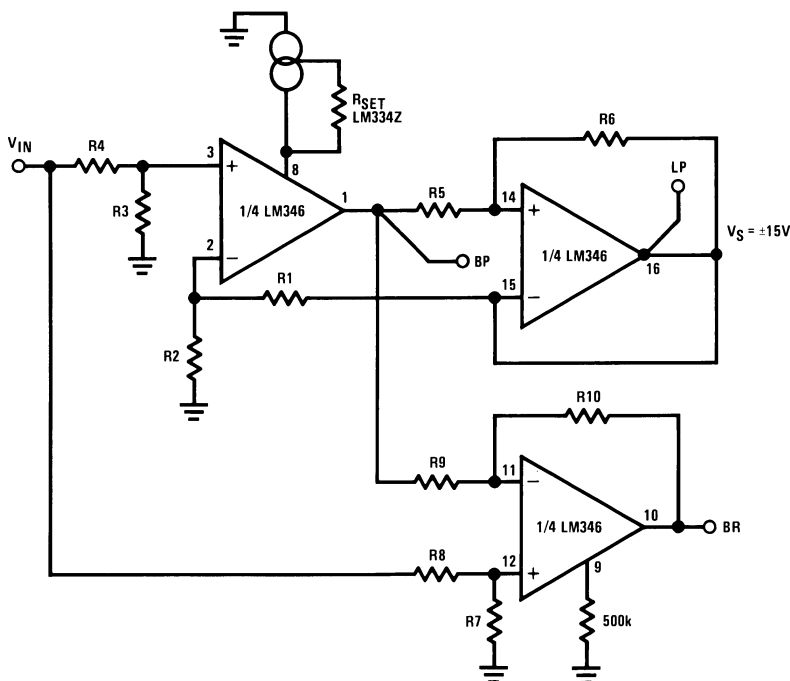

Figure 37. Capacitorless Active Filters (Basic Circuit)

• This is a BP, LP, BR filter. The filter characteristics are created by using the tunable frequency response of the LM346.

• **Limitations:**  $Q_o < 10$ ,  $f_o \times Q_o < 1.5$  MHz, output voltage should not exceed  $V_{peak(out)} \leq \frac{63.66 \times 10^3}{f_o} \times \frac{I_{SET}(\mu A)}{10 \mu A}$  (V)

• Design equations:  $a = \frac{R6 + R5}{R6}$ ,  $b = \frac{R2}{R1 + R2}$ ,  $c = \frac{R3}{R3 + R4}$ ,  $d = \frac{R7}{R8 + R7}$ ,  $e = \frac{R10}{R9 + R10}$ ,  $f_o(BP) = f_u \sqrt{\frac{b}{a}}$ ,  $H_o(BP) = a \times c$ ,  $H_o(LP) = \frac{c}{b}$ ,  $Q_o = \sqrt{a \times b}$

$f_o(BR) = f_o(BP) \left(1 - \frac{c}{b}\right) \cong f_o(BP) (C < 1)$  provided that  $d = H_o(BP) \times e$ ,  $H_o(BR) = \frac{R10}{R9}$ .

• Advantage:  $f_o Q_o$ ,  $H_o$  can be independently adjusted; that is, the filter is extremely easy to tune.

• Tuning procedure (ex. BP tuning)

1. Pick up a convenient value for b; ( $b < 1$ )
2. Adjust  $Q_o$  through R5
3. Adjust  $H_o(BP)$  through R4
4. Adjust  $f_o$  through  $R_{SET}$ . This adjusts the unity gain frequency ( $f_u$ ) of the op amp.

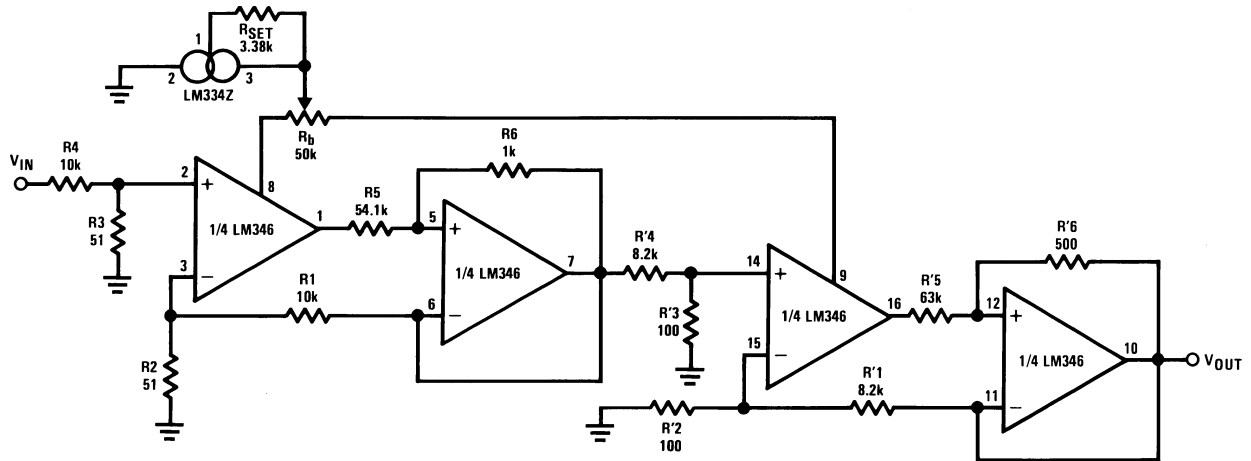

Ex:  $f_c = 20 \text{ kHz}$ ,  $H_o$  (gain of the filter) = 1,  $Q_{o1} = 0.541$ ,  $Q_{o2} = 1.306$ .

• Since for this filter the GBW product of all 4 amplifiers has been designed to be the same (~1 MHz) only one current source can be used to bias the circuit. Fine tuning can be further accomplished through  $R_b$ .

Figure 38. A 4th Order Butterworth Low Pass Capacitorless Filter

### Miscellaneous Applications

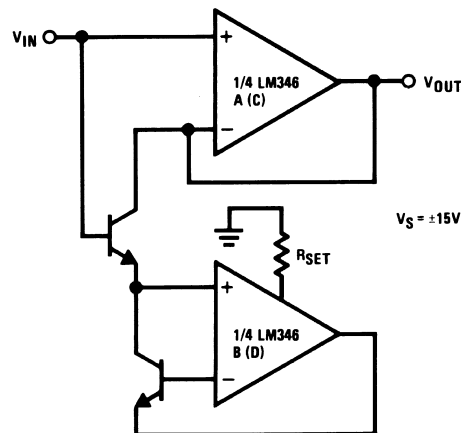

• For better performance, use a matched NPN pair.

Figure 39. A Unity Gain Follower with Bias Current Reduction

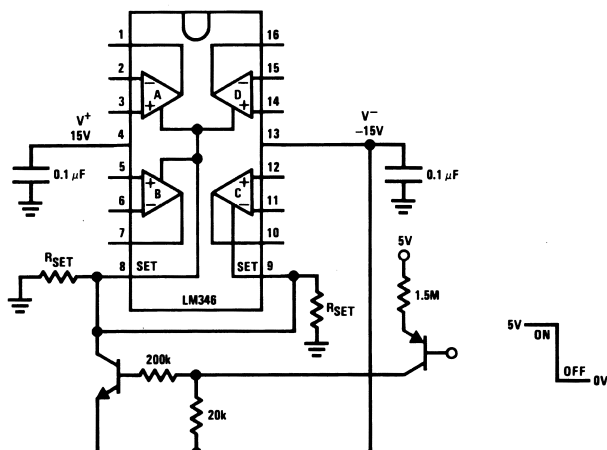

• By pulling the SET pin(s) to V<sup>-</sup> the op amp(s) shuts down and its output goes to a high impedance state. According to this property, the LM346 can be used as a very low speed analog switch.

Figure 40. Circuit Shutdown

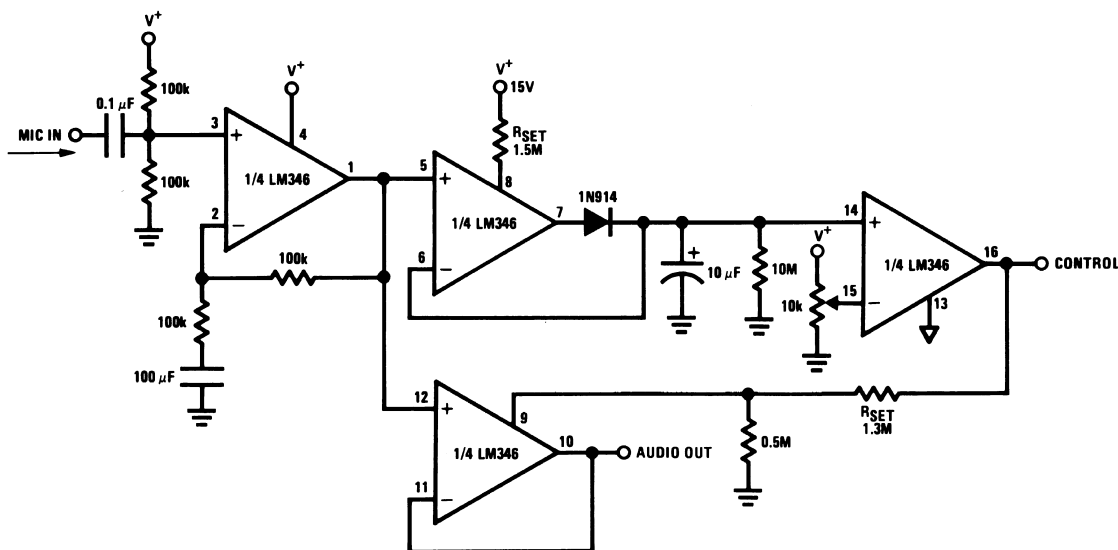
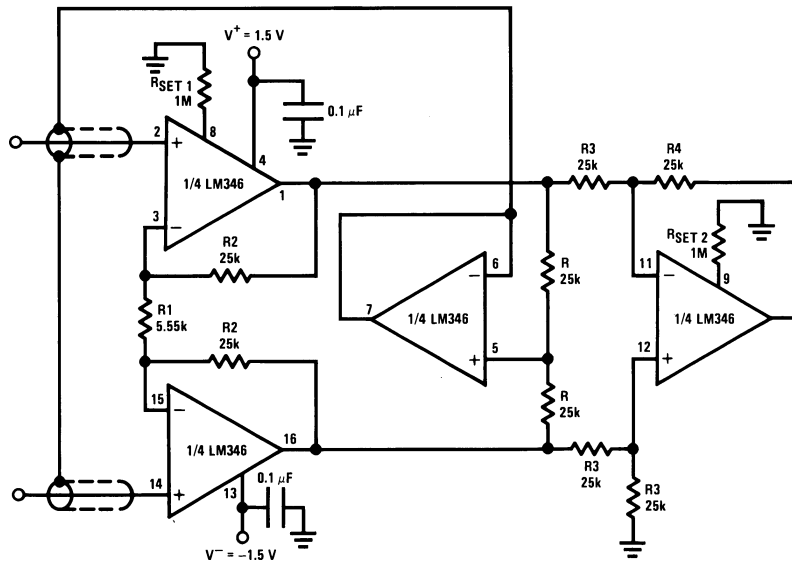

Figure 41. Voice Activated Switch and Amplifier



- CMRR: 100 dB (typ)
- Power dissipation: 0.4 mW

Figure 42. x10 Micropower Instrumentation Amplifier with Buffered Input Guarding

Schematic Diagram

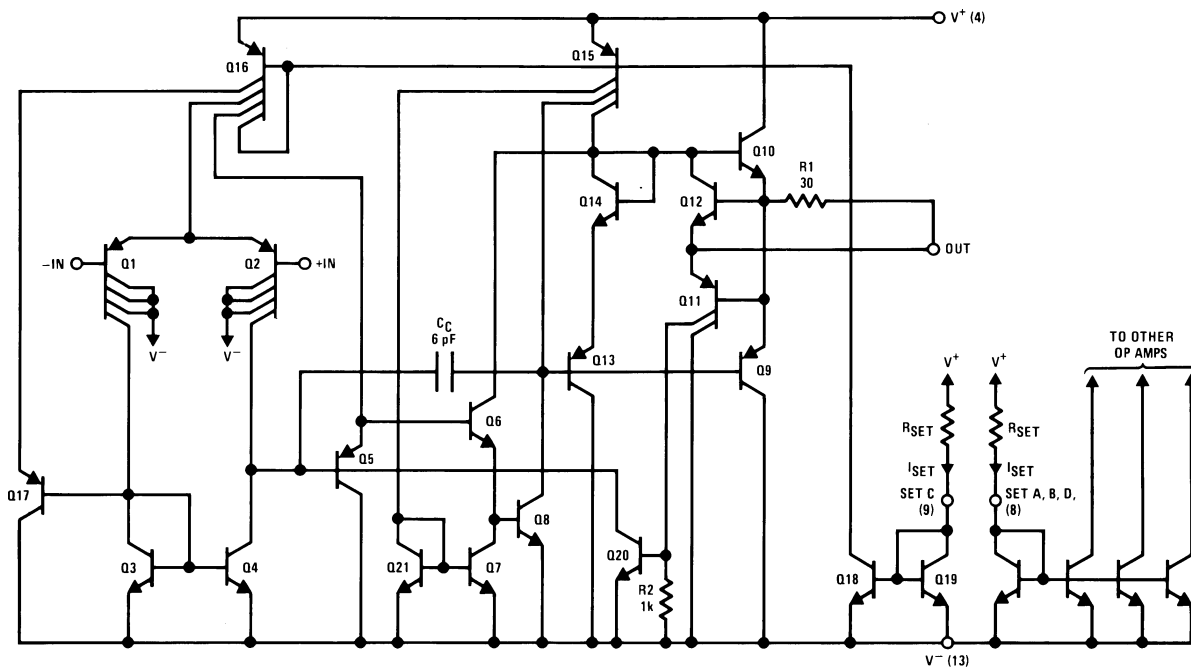

**PACKAGING INFORMATION**

Orderable Device	Status (1)	Package Type	Package Drawing	Pins	Package Qty	Eco Plan (2)	Lead/Ball Finish	MSL Peak Temp (3)	Op Temp (°C)	Top-Side Markings (4)	Samples
LM346M	ACTIVE	SOIC	D	16	48	TBD	Call TI	Call TI	0 to 70	LM346M	<a href="#">Samples</a>
LM346M/NOPB	ACTIVE	SOIC	D	16	48	Green (RoHS & no Sb/Br)	CU SN	Level-1-260C-UNLIM	0 to 70	LM346M	<a href="#">Samples</a>
LM346MX	ACTIVE	SOIC	D	16	2500	TBD	Call TI	Call TI	0 to 70	LM346M	<a href="#">Samples</a>
LM346MX/NOPB	ACTIVE	SOIC	D	16	2500	Green (RoHS & no Sb/Br)	CU SN	Level-1-260C-UNLIM	0 to 70	LM346M	<a href="#">Samples</a>

(1) The marketing status values are defined as follows:

**ACTIVE:** Product device recommended for new designs.

**LIFEBUY:** TI has announced that the device will be discontinued, and a lifetime-buy period is in effect.

**NRND:** Not recommended for new designs. Device is in production to support existing customers, but TI does not recommend using this part in a new design.

**PREVIEW:** Device has been announced but is not in production. Samples may or may not be available.

**OBSOLETE:** TI has discontinued the production of the device.

(2) Eco Plan - The planned eco-friendly classification: Pb-Free (RoHS), Pb-Free (RoHS Exempt), or Green (RoHS & no Sb/Br) - please check <http://www.ti.com/productcontent> for the latest availability information and additional product content details.

**TBD:** The Pb-Free/Green conversion plan has not been defined.

**Pb-Free (RoHS):** TI's terms "Lead-Free" or "Pb-Free" mean semiconductor products that are compatible with the current RoHS requirements for all 6 substances, including the requirement that lead not exceed 0.1% by weight in homogeneous materials. Where designed to be soldered at high temperatures, TI Pb-Free products are suitable for use in specified lead-free processes.

**Pb-Free (RoHS Exempt):** This component has a RoHS exemption for either 1) lead-based flip-chip solder bumps used between the die and package, or 2) lead-based die adhesive used between the die and leadframe. The component is otherwise considered Pb-Free (RoHS compatible) as defined above.

**Green (RoHS & no Sb/Br):** TI defines "Green" to mean Pb-Free (RoHS compatible), and free of Bromine (Br) and Antimony (Sb) based flame retardants (Br or Sb do not exceed 0.1% by weight in homogeneous material)

(3) MSL, Peak Temp. -- The Moisture Sensitivity Level rating according to the JEDEC industry standard classifications, and peak solder temperature.

(4) Multiple Top-Side Markings will be inside parentheses. Only one Top-Side Marking contained in parentheses and separated by a "~" will appear on a device. If a line is indented then it is a continuation of the previous line and the two combined represent the entire Top-Side Marking for that device.

**Important Information and Disclaimer:** The information provided on this page represents TI's knowledge and belief as of the date that it is provided. TI bases its knowledge and belief on information provided by third parties, and makes no representation or warranty as to the accuracy of such information. Efforts are underway to better integrate information from third parties. TI has taken and continues to take reasonable steps to provide representative and accurate information but may not have conducted destructive testing or chemical analysis on incoming materials and chemicals. TI and TI suppliers consider certain information to be proprietary, and thus CAS numbers and other limited information may not be available for release.

In no event shall TI's liability arising out of such information exceed the total purchase price of the TI part(s) at issue in this document sold by TI to Customer on an annual basis.



**TAPE AND REEL INFORMATION**

**QUADRANT ASSIGNMENTS FOR PIN 1 ORIENTATION IN TAPE**

\*All dimensions are nominal

Device	Package Type	Package Drawing	Pins	SPQ	Reel Diameter (mm)	Reel Width W1 (mm)	A0 (mm)	B0 (mm)	K0 (mm)	P1 (mm)	W (mm)	Pin1 Quadrant
LM346MX	SOIC	D	16	2500	330.0	16.4	6.5	10.3	2.3	8.0	16.0	Q1
LM346MX/NOPB	SOIC	D	16	2500	330.0	16.4	6.5	10.3	2.3	8.0	16.0	Q1

**TAPE AND REEL BOX DIMENSIONS**

\*All dimensions are nominal

Device	Package Type	Package Drawing	Pins	SPQ	Length (mm)	Width (mm)	Height (mm)
LM346MX	SOIC	D	16	2500	367.0	367.0	35.0
LM346MX/NOPB	SOIC	D	16	2500	367.0	367.0	35.0

D (R-PDSO-G16)

PLASTIC SMALL OUTLINE



4040047-6/M 06/11

- NOTES:
- A. All linear dimensions are in inches (millimeters).
  - B. This drawing is subject to change without notice.
  -  C. Body length does not include mold flash, protrusions, or gate burrs. Mold flash, protrusions, or gate burrs shall not exceed 0.006 (0,15) each side.
  -  D. Body width does not include interlead flash. Interlead flash shall not exceed 0.017 (0,43) each side.
  - E. Reference JEDEC MS-012 variation AC.

## IMPORTANT NOTICE

Texas Instruments Incorporated and its subsidiaries (TI) reserve the right to make corrections, enhancements, improvements and other changes to its semiconductor products and services per JESD46, latest issue, and to discontinue any product or service per JESD48, latest issue. Buyers should obtain the latest relevant information before placing orders and should verify that such information is current and complete. All semiconductor products (also referred to herein as "components") are sold subject to TI's terms and conditions of sale supplied at the time of order acknowledgment.

TI warrants performance of its components to the specifications applicable at the time of sale, in accordance with the warranty in TI's terms and conditions of sale of semiconductor products. Testing and other quality control techniques are used to the extent TI deems necessary to support this warranty. Except where mandated by applicable law, testing of all parameters of each component is not necessarily performed.

TI assumes no liability for applications assistance or the design of Buyers' products. Buyers are responsible for their products and applications using TI components. To minimize the risks associated with Buyers' products and applications, Buyers should provide adequate design and operating safeguards.

TI does not warrant or represent that any license, either express or implied, is granted under any patent right, copyright, mask work right, or other intellectual property right relating to any combination, machine, or process in which TI components or services are used. Information published by TI regarding third-party products or services does not constitute a license to use such products or services or a warranty or endorsement thereof. Use of such information may require a license from a third party under the patents or other intellectual property of the third party, or a license from TI under the patents or other intellectual property of TI.

Reproduction of significant portions of TI information in TI data books or data sheets is permissible only if reproduction is without alteration and is accompanied by all associated warranties, conditions, limitations, and notices. TI is not responsible or liable for such altered documentation. Information of third parties may be subject to additional restrictions.

Resale of TI components or services with statements different from or beyond the parameters stated by TI for that component or service voids all express and any implied warranties for the associated TI component or service and is an unfair and deceptive business practice. TI is not responsible or liable for any such statements.

Buyer acknowledges and agrees that it is solely responsible for compliance with all legal, regulatory and safety-related requirements concerning its products, and any use of TI components in its applications, notwithstanding any applications-related information or support that may be provided by TI. Buyer represents and agrees that it has all the necessary expertise to create and implement safeguards which anticipate dangerous consequences of failures, monitor failures and their consequences, lessen the likelihood of failures that might cause harm and take appropriate remedial actions. Buyer will fully indemnify TI and its representatives against any damages arising out of the use of any TI components in safety-critical applications.

In some cases, TI components may be promoted specifically to facilitate safety-related applications. With such components, TI's goal is to help enable customers to design and create their own end-product solutions that meet applicable functional safety standards and requirements. Nonetheless, such components are subject to these terms.

No TI components are authorized for use in FDA Class III (or similar life-critical medical equipment) unless authorized officers of the parties have executed a special agreement specifically governing such use.

Only those TI components which TI has specifically designated as military grade or "enhanced plastic" are designed and intended for use in military/aerospace applications or environments. Buyer acknowledges and agrees that any military or aerospace use of TI components which have **not** been so designated is solely at the Buyer's risk, and that Buyer is solely responsible for compliance with all legal and regulatory requirements in connection with such use.

TI has specifically designated certain components as meeting ISO/TS16949 requirements, mainly for automotive use. In any case of use of non-designated products, TI will not be responsible for any failure to meet ISO/TS16949.

### Products

Audio	<a href="http://www.ti.com/audio">www.ti.com/audio</a>
Amplifiers	<a href="http://amplifier.ti.com">amplifier.ti.com</a>
Data Converters	<a href="http://dataconverter.ti.com">dataconverter.ti.com</a>
DLP® Products	<a href="http://www.dlp.com">www.dlp.com</a>
DSP	<a href="http://dsp.ti.com">dsp.ti.com</a>
Clocks and Timers	<a href="http://www.ti.com/clocks">www.ti.com/clocks</a>
Interface	<a href="http://interface.ti.com">interface.ti.com</a>
Logic	<a href="http://logic.ti.com">logic.ti.com</a>
Power Mgmt	<a href="http://power.ti.com">power.ti.com</a>
Microcontrollers	<a href="http://microcontroller.ti.com">microcontroller.ti.com</a>
RFID	<a href="http://www.ti-rfid.com">www.ti-rfid.com</a>
OMAP Applications Processors	<a href="http://www.ti.com/omap">www.ti.com/omap</a>
Wireless Connectivity	<a href="http://www.ti.com/wirelessconnectivity">www.ti.com/wirelessconnectivity</a>

### Applications

Automotive and Transportation	<a href="http://www.ti.com/automotive">www.ti.com/automotive</a>
Communications and Telecom	<a href="http://www.ti.com/communications">www.ti.com/communications</a>
Computers and Peripherals	<a href="http://www.ti.com/computers">www.ti.com/computers</a>
Consumer Electronics	<a href="http://www.ti.com/consumer-apps">www.ti.com/consumer-apps</a>
Energy and Lighting	<a href="http://www.ti.com/energy">www.ti.com/energy</a>
Industrial	<a href="http://www.ti.com/industrial">www.ti.com/industrial</a>
Medical	<a href="http://www.ti.com/medical">www.ti.com/medical</a>
Security	<a href="http://www.ti.com/security">www.ti.com/security</a>
Space, Avionics and Defense	<a href="http://www.ti.com/space-avionics-defense">www.ti.com/space-avionics-defense</a>
Video and Imaging	<a href="http://www.ti.com/video">www.ti.com/video</a>

### TI E2E Community

[e2e.ti.com](http://e2e.ti.com)