

## FEATURES

- **Wide Power-Supply Voltage Range**
  - Single Supply: 3 V to 32 V
  - Dual Supply:  $\pm 1.5$  V to  $\pm 16$  V
- **Low Supply-Current Drain Essentially Independent of Supply Voltage: 600  $\mu$ A**
- **Low Input Biasing Current: 50 nA**
- **Low Input Offset Voltage: 2 mV**
- **Low Input Offset Current: 5 nA**
- **Input Common-Mode Voltage Range Includes Ground**
- **Differential Input Voltage Range Equals Power-Supply Voltage**
- **Additional Operational Amplifier Features**
  - Internally Frequency Compensated for Unity Gain
  - Large DC Voltage Gain: 100 dB
  - Wide Bandwidth (Unity Gain): 1 MHz
  - Large Output Voltage Swing: 0 V to  $V_+ - 1.5$  V

- **Additional Comparator Features**
  - Low Output Saturation Voltage: 250 mV at 4 mA
  - Output Voltage Compatible With All Types of Logic Systems

## ADVANTAGES

- **Eliminates Need for Dual Power Supplies**
- **An Internally Compensated Operational Amplifier and a Precision Comparator in the Same Package**
- **Allows Sensing at or Near Ground**

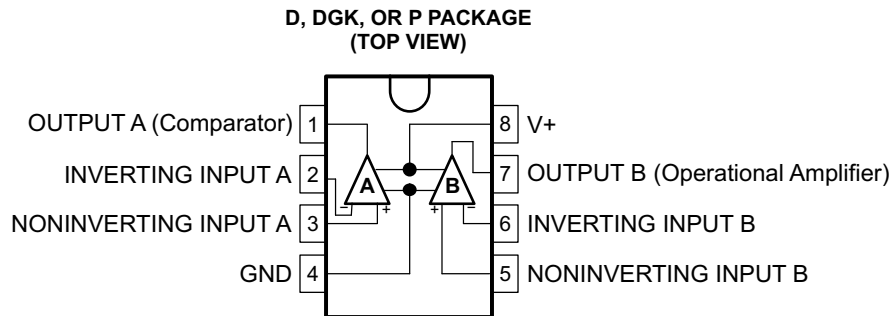

## DESCRIPTION/ORDERING INFORMATION

The LM392 consists of two independent building-block circuits. One is a high-gain internally-frequency-compensated operational amplifier, and the other is a precision voltage comparator. Both the operational amplifier and the voltage comparator are designed to operate from a single power supply over a wide range of voltages. Both circuits have input stages that force the common-mode input down to ground when operating from a single power supply. Operation from split power supplies also is possible, and the low power-supply current is independent of the magnitude of the supply voltage.

Applications include transducer amplifiers with pulse shapers, DC gain blocks with level detectors, and VCOs, as well as all conventional operational amplifier or voltage-comparator circuits. The LM392 can be operated directly from the standard 5-V power-supply voltage used in digital systems, and the output of the comparator interfaces directly with either TTL or CMOS logic. In addition, the low-power drain makes the LM392 extremely useful in the design of portable equipment.



Please be aware that an important notice concerning availability, standard warranty, and use in critical applications of Texas Instruments semiconductor products and disclaimers thereto appears at the end of this data sheet.

**ORDERING INFORMATION**

T <sub>A</sub>	PACKAGE <sup>(1)</sup>		ORDERABLE PART NUMBER	TOP-SIDE MARKING
0°C to 70°C	MSOP – DGK	Reel of 250	LM392DGKT	PREVIEW
		Reel of 2500	LM392DGKR	
	PDIP – P	Tube of 50	LM392P	LM392P
	SOIC – D	Tube of 75	LM392D	LM392
		Reel of 2500	LM392DR	

(1) Package drawings, standard packing quantities, thermal data, symbolization, and PCB design guidelines are available at [www.ti.com/sc/package](http://www.ti.com/sc/package).

**SCHEMATIC DIAGRAM**

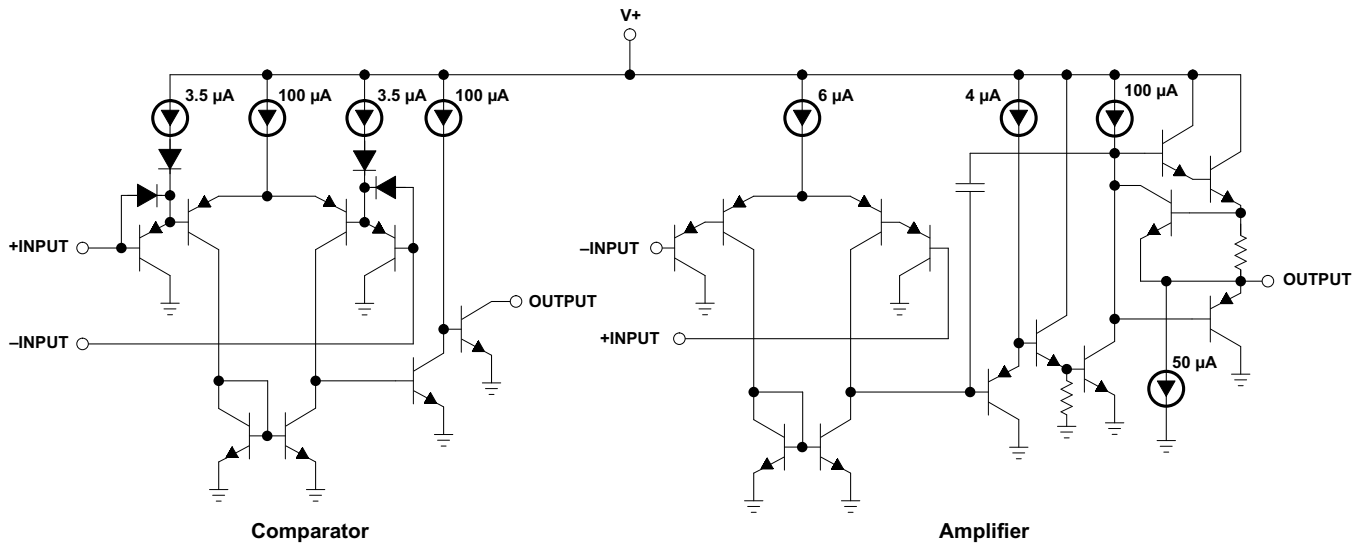

### Absolute Maximum Ratings<sup>(1)</sup>

over operating free-air temperature range (unless otherwise noted)

		MIN	MAX	UNIT
V+	Supply voltage	Single supply	32	V
		Dual supply	±16	
V <sub>ID</sub>	Differential input voltage		32	V
V <sub>IN</sub>	Input voltage range	–0.3	32	V
I <sub>I</sub>	Input current <sup>(2)</sup>	V <sub>IN</sub> < –0.3 V	50	mA
t <sub>short</sub>	Duration of output short circuit to ground <sup>(3)</sup>		Continuous	
θ <sub>JA</sub>	Package thermal impedance, junction to free air <sup>(4)</sup>	D package	97	°C/W
		DGK package	172	
		P package	84	
T <sub>lead</sub>	Lead temperature during soldering	10 s maximum	260	°C
T <sub>stg</sub>	Storage temperature range	–65	150	°C

- (1) Stresses beyond those listed under *Absolute Maximum Ratings* may cause permanent damage to the device. These are stress ratings only, and functional operation of the device at these or any other conditions beyond those indicated under *Recommended Operating Conditions* is not implied. Exposure to absolute-maximum-rated conditions for extended periods may affect device reliability.
- (2) This input current exists only when the voltage at any of the input leads is driven negative. It is due to the collector-base junction of the input PNP transistors becoming forward biased and thereby acting as input diode clamps. In addition to this diode action, there is also lateral NPN parasitic transistor action on the device. This transistor action can cause the output voltages of the amplifiers to go to the V+ voltage level (or to ground for a large overdrive) for the time duration that an input is driven negative. This is not destructive, and normal output states reestablish when the input voltage, which was negative, again returns to a value greater than –0.3 V (at 25°C).
- (3) Short circuits from the output to V+ can cause excessive heating and eventual destruction. When considering short circuits to ground, the maximum output current is approximately 40 mA for the operational amplifier and 30 mA for the comparator, independent of the magnitude of V+. At values of supply voltage in excess of 15 V, continuous short circuits can exceed the power dissipation ratings and cause eventual destruction.
- (4) Package thermal impedance is calculated in accordance with JESD 51-7.

### Recommended Operating Conditions

		MIN	MAX	UNIT	
V+	Supply voltage	Single supply	3	32	V
		Dual supply	±1.5	±16	
T <sub>A</sub>	Operating free-air temperature	0	70	°C	

## Electrical Characteristics

V+ = 5 V (unless otherwise noted)

PARAMETER		TEST CONDITIONS		T <sub>A</sub>	MIN	TYP	MAX	UNIT
V <sub>IO</sub>	Input offset voltage	At output switch point, V <sub>O</sub> ≈ 1.4 V, R <sub>S</sub> = 0 Ω, V+ = 5 V to 30 V, V <sub>CM</sub> = 0 V to (V+ – 1.5 V)		25°C		±2	±5	mV
				0°C to 70°C				
I <sub>IB</sub>	Input bias current	IN(+) or IN(–), V <sub>CM</sub> = 0 V <sup>(1)</sup>		25°C		50	205	nA
		IN(+) or IN(–)		0°C to 70°C			400	
I <sub>IO</sub>	Input offset current	IN(+) – IN(–)		25°C		±5	±50	nA
				0°C to 70°C				
V <sub>CM</sub>	Input common-mode voltage <sup>(2)</sup>	V+ = 30 V		25°C	0		V+ – 1.5	V
				0°C to 70°C	0		V+ – 2	
I+	Supply current	R <sub>L</sub> = ∞	V+ = 30 V	0°C to 70°C		1	2	mA
			V+ = 5 V			0.5	1	
	Amplifier-to-amplifier coupling	f = 1 kHz to 20 kHz, Input referred <sup>(3)</sup>		25°C		–100		dB
V <sub>DI</sub>	Differential input voltage	All V <sub>IN</sub> ≥ 0 V (or V–, if used) <sup>(4)</sup>		0°C to 70°C			32	V

- (1) The direction of the input current is out of the device due to the PNP input stage. This current essentially is constant and independent of the state of the output, so no loading change exists on the input lines.
- (2) The input common-mode voltage or either input signal voltage should not be allowed to go negative by more than 0.3 V. The upper end of the common-mode voltage range is V+ – 1.5 V, but either or both inputs can go to 32 V without damage.
- (3) Due to proximity of external components, ensure that coupling is not originating via the stray capacitance between these external parts. This typically can be detected, as this type of capacitive coupling increases at higher frequencies.
- (4) Positive excursions of input voltage may exceed the power-supply level. As long as the other input voltage remains within the common-mode range, the comparator provides a proper output state. The input voltage to the operational amplifier should not exceed the power-supply level. The input voltage state must not be less than –0.3 V (or 0.3 V below the magnitude of the negative power supply, if used) on either amplifier.

## Electrical Characteristics, Operational Amplifier Only

V+ = 5 V (unless otherwise noted)

PARAMETER		TEST CONDITIONS		T <sub>A</sub>	MIN	TYP	MAX	UNIT
A <sub>VD</sub>	Large signal voltage gain	V+ = 15 V, V <sub>O</sub> swing = 1 V to 11 V, R <sub>L</sub> = 2 kΩ		25°C	25	100		V/mV
V <sub>OS</sub>	Output voltage swing	R <sub>L</sub> = 2 kΩ		25°C	0		V+ – 1.5	V
CMRR	Common-mode rejection ratio	V <sub>CM</sub> = 0 V to (V+ – 1.5 V)		25°C	65	70		dB
k <sub>SVR</sub>	Power-supply rejection ratio			25°C	65	100		dB
I <sub>source</sub>	Output source current	V <sub>IN(+)</sub> = 1 V, V <sub>IN(–)</sub> = 0 V, V+ = 15 V, V <sub>O</sub> = 2 V		25°C	20	40		mA
I <sub>sink</sub>	Output sink current	V <sub>IN(–)</sub> = 1 V, V <sub>IN(+)</sub> = 0 V, V+ = 15 V	V <sub>O</sub> = 2 V	25°C		10	20	mA
			V <sub>O</sub> = 200 mV			12	50	μA
αV <sub>IO</sub>	Input offset voltage drift	R <sub>S</sub> = 0 Ω		0°C to 70°C		7		μV/°C
αI <sub>IO</sub>	Input offset current drift	R <sub>S</sub> = 0 Ω		0°C to 70°C		10		pA/°C

**Electrical Characteristics, Comparator Only**
 $V_+ = 5\text{ V}$  (unless otherwise noted)

PARAMETER		TEST CONDITIONS	$T_A$	MIN	TYP	MAX	UNIT
$V_G$	Voltage gain	$R_L \geq 15\text{ k}\Omega$ , $V_+ = 15\text{ V}$	25°C	50	200		V/mV
$t_{LSR}$	Large signal response time	$V_{IN} = \text{TTL logic swing}$ , $V_{REF} = 1.4\text{ V}$ , $V_{RL} = 5\text{ V}$ , $R_L = 5.1\text{ k}\Omega$	25°C		300		ns
$t_R$	Response time	$V_{RL} = 5\text{ V}$ , $R_L = 5.1\text{ k}\Omega$	25°C		1.3		$\mu\text{s}$
$I_{SINK}$	Output sink current	$V_{IN(-)} = 1\text{ V}$ , $V_{IN(+)} = 0\text{ V}$ , $V_O \geq 1.5\text{ V}$	25°C	6	16		mA
$V_S$	Saturation voltage	$V_{IN(-)} \geq 1\text{ V}$ , $V_{IN(+)} = 0$ , $I_{SINK} \leq 4\text{ mA}$	25°C		250	400	mV
			0°C to 70°C			700	
$I_{LO}$	Output leakage current	$V_{IN(-)} = 0$ , $V_{IN(+)} \geq 1\text{ V}$	$V_O = 5\text{ V}$	25°C		0.1	nA
			$V_O = 30\text{ V}$	0°C to 70°C			1

**PACKAGING INFORMATION**

Orderable Device	Status (1)	Package Type	Package Drawing	Pins	Package Qty	Eco Plan (2)	Lead/Ball Finish	MSL Peak Temp (3)	Op Temp (°C)	Top-Side Markings (4)	Samples
LM392D	ACTIVE	SOIC	D	8	75	Green (RoHS & no Sb/Br)	CU NIPDAU	Level-1-260C-UNLIM	0 to 70	LM392	<a href="#">Samples</a>
LM392DG4	ACTIVE	SOIC	D	8	75	Green (RoHS & no Sb/Br)	CU NIPDAU	Level-1-260C-UNLIM	0 to 70	LM392	<a href="#">Samples</a>
LM392DGKR	ACTIVE	VSSOP	DGK	8	2500	Green (RoHS & no Sb/Br)	CU NIPDAU	Level-1-260C-UNLIM	0 to 70	M7L	<a href="#">Samples</a>
LM392DGKRG4	ACTIVE	VSSOP	DGK	8	2500	Green (RoHS & no Sb/Br)	CU NIPDAU	Level-1-260C-UNLIM	0 to 70	M7L	<a href="#">Samples</a>
LM392DGKT	ACTIVE	VSSOP	DGK	8	250	Green (RoHS & no Sb/Br)	CU NIPDAU	Level-1-260C-UNLIM	0 to 70	M7L	<a href="#">Samples</a>
LM392DGKTG4	ACTIVE	VSSOP	DGK	8	250	Green (RoHS & no Sb/Br)	CU NIPDAU	Level-1-260C-UNLIM	0 to 70	M7L	<a href="#">Samples</a>
LM392DR	ACTIVE	SOIC	D	8	2500	Green (RoHS & no Sb/Br)	CU NIPDAU	Level-1-260C-UNLIM	0 to 70	LM392	<a href="#">Samples</a>
LM392DRG4	ACTIVE	SOIC	D	8	2500	Green (RoHS & no Sb/Br)	CU NIPDAU	Level-1-260C-UNLIM	0 to 70	LM392	<a href="#">Samples</a>
LM392P	ACTIVE	PDIP	P	8	50	Pb-Free (RoHS)	CU NIPDAU	N / A for Pkg Type	0 to 70	LM392P	<a href="#">Samples</a>
LM392PE4	ACTIVE	PDIP	P	8	50	Pb-Free (RoHS)	CU NIPDAU	N / A for Pkg Type	0 to 70	LM392P	<a href="#">Samples</a>

(1) The marketing status values are defined as follows:

**ACTIVE:** Product device recommended for new designs.

**LIFEBUY:** TI has announced that the device will be discontinued, and a lifetime-buy period is in effect.

**NRND:** Not recommended for new designs. Device is in production to support existing customers, but TI does not recommend using this part in a new design.

**PREVIEW:** Device has been announced but is not in production. Samples may or may not be available.

**OBSOLETE:** TI has discontinued the production of the device.

(2) Eco Plan - The planned eco-friendly classification: Pb-Free (RoHS), Pb-Free (RoHS Exempt), or Green (RoHS & no Sb/Br) - please check <http://www.ti.com/productcontent> for the latest availability information and additional product content details.

**TBD:** The Pb-Free/Green conversion plan has not been defined.

**Pb-Free (RoHS):** TI's terms "Lead-Free" or "Pb-Free" mean semiconductor products that are compatible with the current RoHS requirements for all 6 substances, including the requirement that lead not exceed 0.1% by weight in homogeneous materials. Where designed to be soldered at high temperatures, TI Pb-Free products are suitable for use in specified lead-free processes.

**Pb-Free (RoHS Exempt):** This component has a RoHS exemption for either 1) lead-based flip-chip solder bumps used between the die and package, or 2) lead-based die adhesive used between the die and leadframe. The component is otherwise considered Pb-Free (RoHS compatible) as defined above.

**Green (RoHS & no Sb/Br):** TI defines "Green" to mean Pb-Free (RoHS compatible), and free of Bromine (Br) and Antimony (Sb) based flame retardants (Br or Sb do not exceed 0.1% by weight in homogeneous material)

(3) MSL, Peak Temp. -- The Moisture Sensitivity Level rating according to the JEDEC industry standard classifications, and peak solder temperature.

(4) Multiple Top-Side Markings will be inside parentheses. Only one Top-Side Marking contained in parentheses and separated by a "~" will appear on a device. If a line is indented then it is a continuation of the previous line and the two combined represent the entire Top-Side Marking for that device.

**Important Information and Disclaimer:**The information provided on this page represents TI's knowledge and belief as of the date that it is provided. TI bases its knowledge and belief on information provided by third parties, and makes no representation or warranty as to the accuracy of such information. Efforts are underway to better integrate information from third parties. TI has taken and continues to take reasonable steps to provide representative and accurate information but may not have conducted destructive testing or chemical analysis on incoming materials and chemicals. TI and TI suppliers consider certain information to be proprietary, and thus CAS numbers and other limited information may not be available for release.

In no event shall TI's liability arising out of such information exceed the total purchase price of the TI part(s) at issue in this document sold by TI to Customer on an annual basis.

## TAPE AND REEL INFORMATION



### QUADRANT ASSIGNMENTS FOR PIN 1 ORIENTATION IN TAPE



\*All dimensions are nominal

Device	Package Type	Package Drawing	Pins	SPQ	Reel Diameter (mm)	Reel Width W1 (mm)	A0 (mm)	B0 (mm)	K0 (mm)	P1 (mm)	W (mm)	Pin1 Quadrant
LM392DGKR	VSSOP	DGK	8	2500	330.0	12.4	5.3	3.4	1.4	8.0	12.0	Q1
LM392DGKT	VSSOP	DGK	8	250	177.8	12.4	5.3	3.4	1.4	8.0	12.0	Q1
LM392DR	SOIC	D	8	2500	330.0	12.4	6.4	5.2	2.1	8.0	12.0	Q1
LM392DRG4	SOIC	D	8	2500	330.0	12.4	6.4	5.2	2.1	8.0	12.0	Q1

**TAPE AND REEL BOX DIMENSIONS**

\*All dimensions are nominal

Device	Package Type	Package Drawing	Pins	SPQ	Length (mm)	Width (mm)	Height (mm)
LM392DGKR	VSSOP	DGK	8	2500	358.0	335.0	35.0
LM392DGKT	VSSOP	DGK	8	250	202.0	201.0	28.0
LM392DR	SOIC	D	8	2500	340.5	338.1	20.6
LM392DRG4	SOIC	D	8	2500	340.5	338.1	20.6

P (R-PDIP-T8)

PLASTIC DUAL-IN-LINE PACKAGE

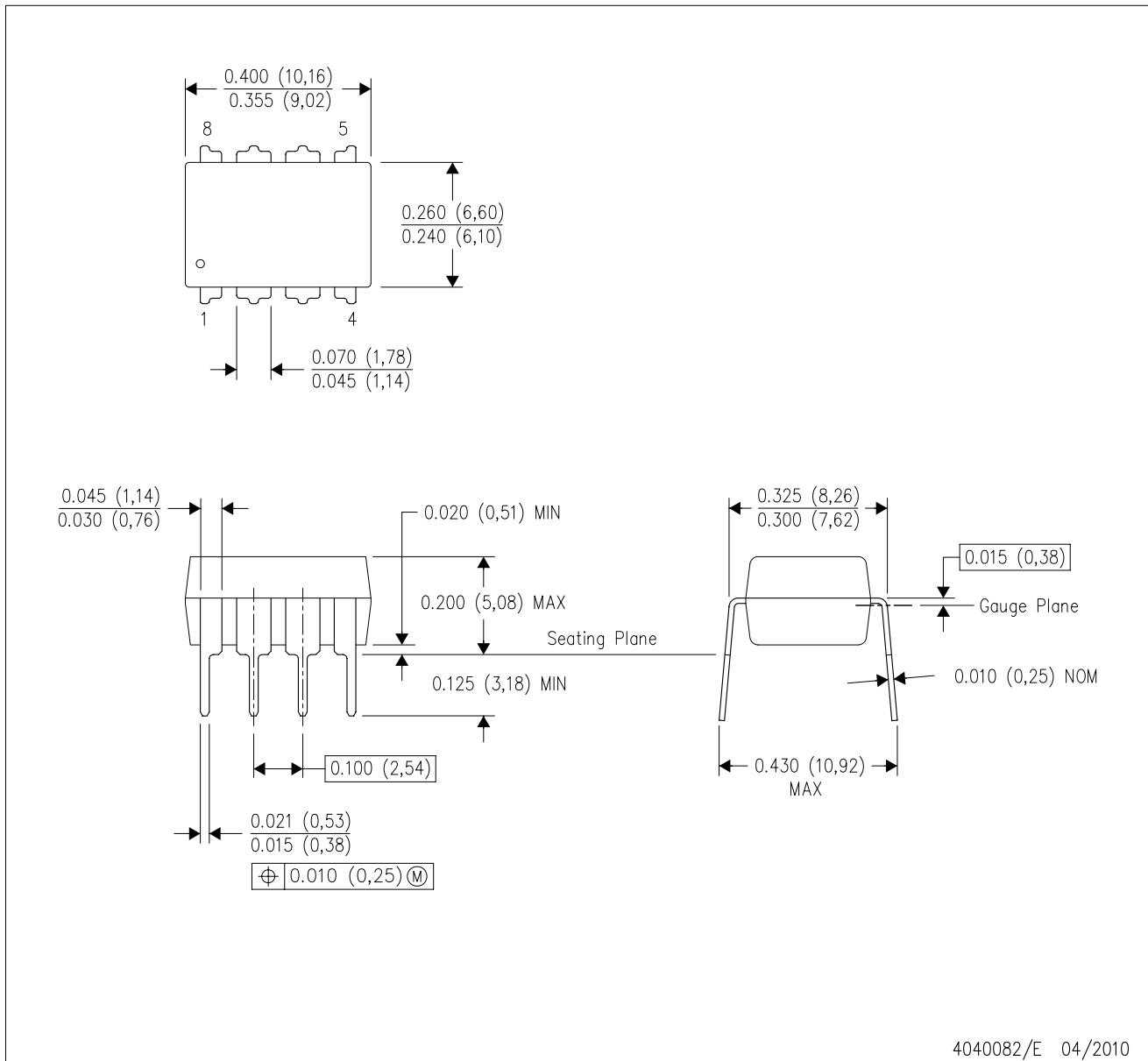

- NOTES:
- A. All linear dimensions are in inches (millimeters).
  - B. This drawing is subject to change without notice.
  - C. Falls within JEDEC MS-001 variation BA.

DGK (S-PDSO-G8)

PLASTIC SMALL-OUTLINE PACKAGE

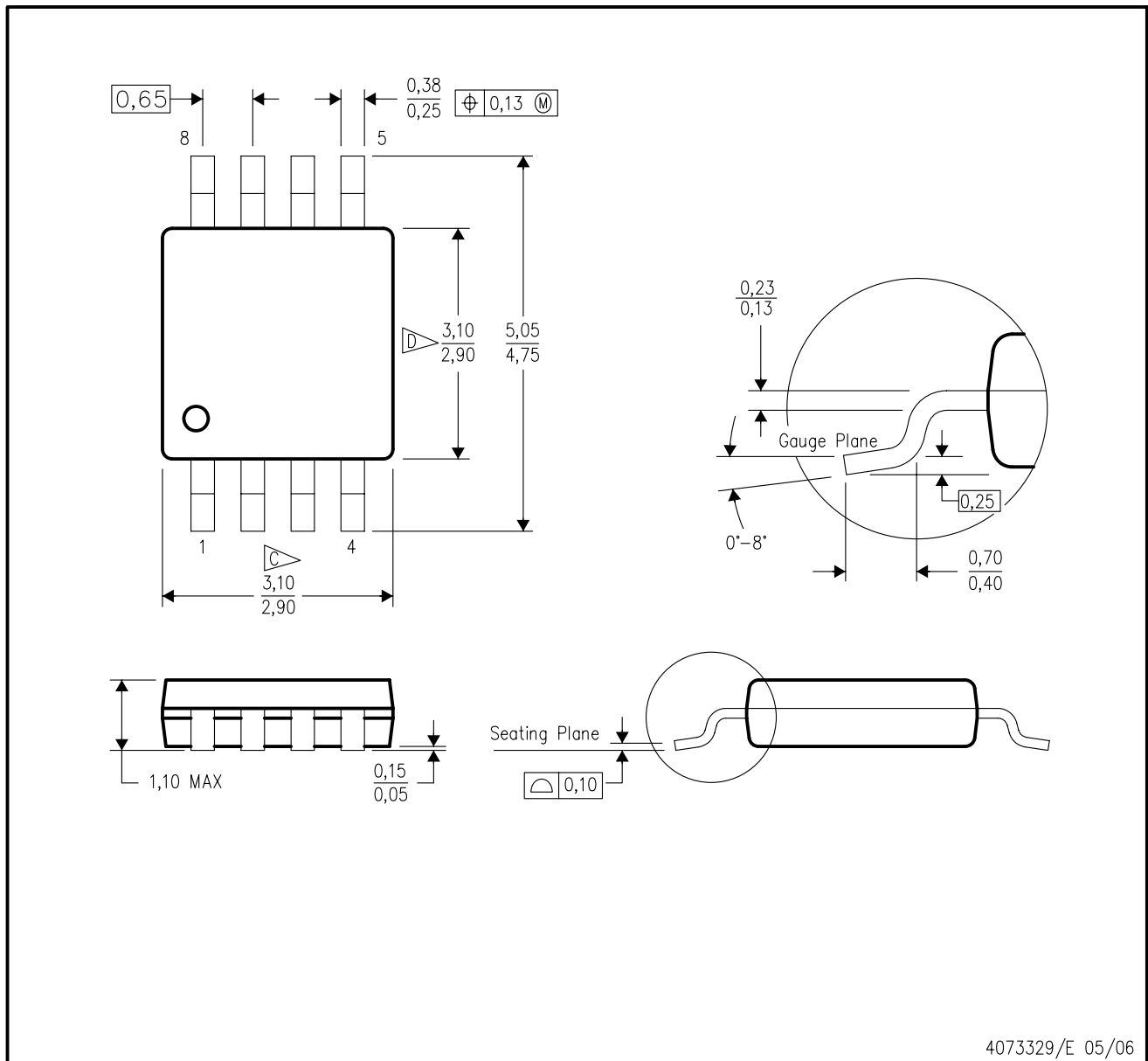

- NOTES:
- A. All linear dimensions are in millimeters.
  - B. This drawing is subject to change without notice.
  - C. Body length does not include mold flash, protrusions, or gate burrs. Mold flash, protrusions, or gate burrs shall not exceed 0.15 per end.
  - D. Body width does not include interlead flash. Interlead flash shall not exceed 0.50 per side.
  - E. Falls within JEDEC MO-187 variation AA, except interlead flash.



D (R-PDSO-G8)

PLASTIC SMALL OUTLINE

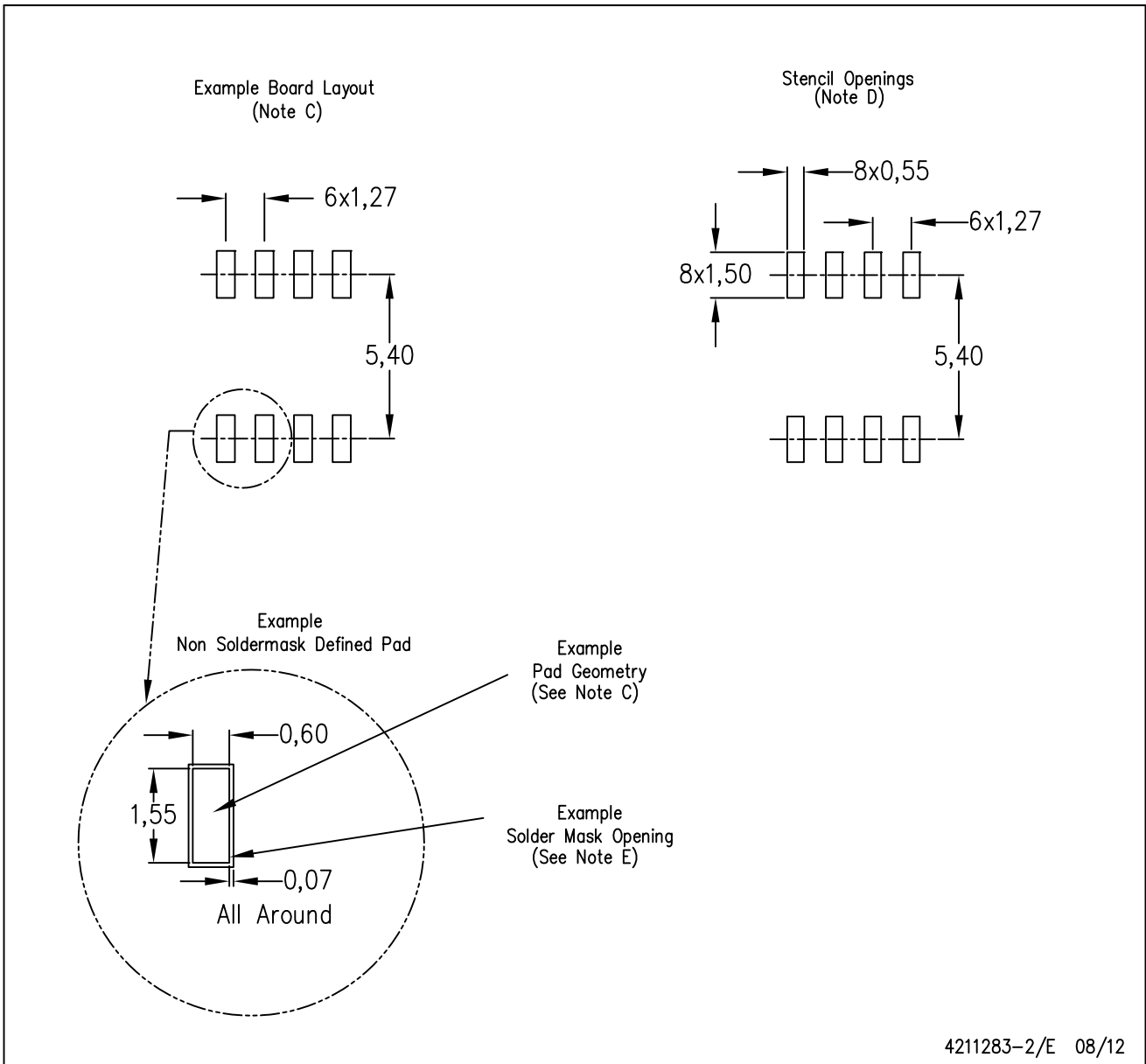

4211283-2/E 08/12

- NOTES:
- A. All linear dimensions are in millimeters.
  - B. This drawing is subject to change without notice.
  - C. Publication IPC-7351 is recommended for alternate designs.
  - D. Laser cutting apertures with trapezoidal walls and also rounding corners will offer better paste release. Customers should contact their board assembly site for stencil design recommendations. Refer to IPC-7525 for other stencil recommendations.
  - E. Customers should contact their board fabrication site for solder mask tolerances between and around signal pads.

## IMPORTANT NOTICE

Texas Instruments Incorporated and its subsidiaries (TI) reserve the right to make corrections, enhancements, improvements and other changes to its semiconductor products and services per JESD46, latest issue, and to discontinue any product or service per JESD48, latest issue. Buyers should obtain the latest relevant information before placing orders and should verify that such information is current and complete. All semiconductor products (also referred to herein as "components") are sold subject to TI's terms and conditions of sale supplied at the time of order acknowledgment.

TI warrants performance of its components to the specifications applicable at the time of sale, in accordance with the warranty in TI's terms and conditions of sale of semiconductor products. Testing and other quality control techniques are used to the extent TI deems necessary to support this warranty. Except where mandated by applicable law, testing of all parameters of each component is not necessarily performed.

TI assumes no liability for applications assistance or the design of Buyers' products. Buyers are responsible for their products and applications using TI components. To minimize the risks associated with Buyers' products and applications, Buyers should provide adequate design and operating safeguards.

TI does not warrant or represent that any license, either express or implied, is granted under any patent right, copyright, mask work right, or other intellectual property right relating to any combination, machine, or process in which TI components or services are used. Information published by TI regarding third-party products or services does not constitute a license to use such products or services or a warranty or endorsement thereof. Use of such information may require a license from a third party under the patents or other intellectual property of the third party, or a license from TI under the patents or other intellectual property of TI.

Reproduction of significant portions of TI information in TI data books or data sheets is permissible only if reproduction is without alteration and is accompanied by all associated warranties, conditions, limitations, and notices. TI is not responsible or liable for such altered documentation. Information of third parties may be subject to additional restrictions.

Resale of TI components or services with statements different from or beyond the parameters stated by TI for that component or service voids all express and any implied warranties for the associated TI component or service and is an unfair and deceptive business practice. TI is not responsible or liable for any such statements.

Buyer acknowledges and agrees that it is solely responsible for compliance with all legal, regulatory and safety-related requirements concerning its products, and any use of TI components in its applications, notwithstanding any applications-related information or support that may be provided by TI. Buyer represents and agrees that it has all the necessary expertise to create and implement safeguards which anticipate dangerous consequences of failures, monitor failures and their consequences, lessen the likelihood of failures that might cause harm and take appropriate remedial actions. Buyer will fully indemnify TI and its representatives against any damages arising out of the use of any TI components in safety-critical applications.

In some cases, TI components may be promoted specifically to facilitate safety-related applications. With such components, TI's goal is to help enable customers to design and create their own end-product solutions that meet applicable functional safety standards and requirements. Nonetheless, such components are subject to these terms.

No TI components are authorized for use in FDA Class III (or similar life-critical medical equipment) unless authorized officers of the parties have executed a special agreement specifically governing such use.

Only those TI components which TI has specifically designated as military grade or "enhanced plastic" are designed and intended for use in military/aerospace applications or environments. Buyer acknowledges and agrees that any military or aerospace use of TI components which have **not** been so designated is solely at the Buyer's risk, and that Buyer is solely responsible for compliance with all legal and regulatory requirements in connection with such use.

TI has specifically designated certain components as meeting ISO/TS16949 requirements, mainly for automotive use. In any case of use of non-designated products, TI will not be responsible for any failure to meet ISO/TS16949.

### Products

Audio	<a href="http://www.ti.com/audio">www.ti.com/audio</a>
Amplifiers	<a href="http://amplifier.ti.com">amplifier.ti.com</a>
Data Converters	<a href="http://dataconverter.ti.com">dataconverter.ti.com</a>
DLP® Products	<a href="http://www.dlp.com">www.dlp.com</a>
DSP	<a href="http://dsp.ti.com">dsp.ti.com</a>
Clocks and Timers	<a href="http://www.ti.com/clocks">www.ti.com/clocks</a>
Interface	<a href="http://interface.ti.com">interface.ti.com</a>
Logic	<a href="http://logic.ti.com">logic.ti.com</a>
Power Mgmt	<a href="http://power.ti.com">power.ti.com</a>
Microcontrollers	<a href="http://microcontroller.ti.com">microcontroller.ti.com</a>
RFID	<a href="http://www.ti-rfid.com">www.ti-rfid.com</a>
OMAP Applications Processors	<a href="http://www.ti.com/omap">www.ti.com/omap</a>
Wireless Connectivity	<a href="http://www.ti.com/wirelessconnectivity">www.ti.com/wirelessconnectivity</a>

### Applications

Automotive and Transportation	<a href="http://www.ti.com/automotive">www.ti.com/automotive</a>
Communications and Telecom	<a href="http://www.ti.com/communications">www.ti.com/communications</a>
Computers and Peripherals	<a href="http://www.ti.com/computers">www.ti.com/computers</a>
Consumer Electronics	<a href="http://www.ti.com/consumer-apps">www.ti.com/consumer-apps</a>
Energy and Lighting	<a href="http://www.ti.com/energy">www.ti.com/energy</a>
Industrial	<a href="http://www.ti.com/industrial">www.ti.com/industrial</a>
Medical	<a href="http://www.ti.com/medical">www.ti.com/medical</a>
Security	<a href="http://www.ti.com/security">www.ti.com/security</a>
Space, Avionics and Defense	<a href="http://www.ti.com/space-avionics-defense">www.ti.com/space-avionics-defense</a>
Video and Imaging	<a href="http://www.ti.com/video">www.ti.com/video</a>

### TI E2E Community

[e2e.ti.com](http://e2e.ti.com)