

LM341/LM78MXX Series 3-Terminal Positive Voltage Regulators

 Check for Samples: [LM341/LM78MXX](#)

FEATURES

- Output Current in Excess of 0.5A
- No External Components
- Internal Thermal Overload Protection
- Internal Short Circuit Current-Limiting
- Output Transistor Safe-Area Compensation
- Available in TO-220, TO, and PFM D-PAK Packages
- Output Voltages of 5V, 12V, and 15V

DESCRIPTION

The LM341 and LM78MXX series of three-terminal positive voltage regulators employ built-in current limiting, thermal shutdown, and safe-operating area protection which makes them virtually immune to damage from output overloads.

With adequate heatsinking, they can deliver in excess of 0.5A output current. Typical applications would include local (on-card) regulators which can eliminate the noise and degraded performance associated with single-point regulation.

Connection Diagram

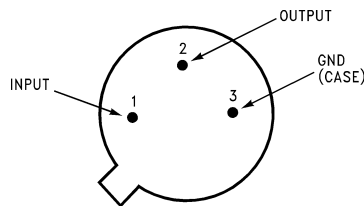

Figure 1. TO Metal Can Package (NDT) - Bottom View
See Package Number NDT0003A

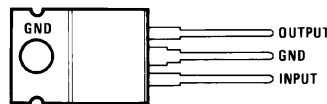

Figure 2. TO-220 Power Package (NDE) - Top View
See Package Number NDE0003B

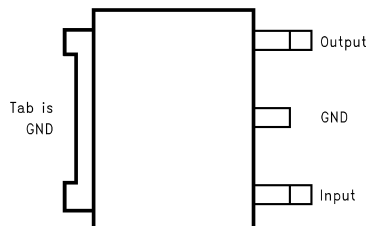

Figure 3. PFM - Top View
See Package Number NDP0003B



These devices have limited built-in ESD protection. The leads should be shorted together or the device placed in conductive foam during storage or handling to prevent electrostatic damage to the MOS gates.



Please be aware that an important notice concerning availability, standard warranty, and use in critical applications of Texas Instruments semiconductor products and disclaimers thereto appears at the end of this data sheet.

All trademarks are the property of their respective owners.

ABSOLUTE MAXIMUM RATINGS⁽¹⁾⁽²⁾

Lead Temperature (Soldering, 10 seconds)	TO Package (NDT)	300°C
	TO-220 Package (NDE)	260°C
Storage Temperature Range		-65°C to +150°C
Operating Junction Temperature Range		-40°C to +125°C
Power Dissipation ⁽³⁾		Internally Limited
Input Voltage $5V \leq V_O \leq 15V$		35V
ESD Susceptibility		TBD

- (1) Absolute maximum ratings indicate limits beyond which damage to the component may occur. Electrical specifications do not apply when operating the device outside of its rated operating conditions.
- (2) If Military/Aerospace specified devices are required, please contact the Texas Instruments Sales Office/ Distributors for availability and specifications.
- (3) The typical thermal resistance of the three package types is: **NDE** (TO-220) package: $\theta_{(JA)} = 60 \text{ }^\circ\text{C/W}$, $\theta_{(JC)} = 5 \text{ }^\circ\text{C/W}$ **NDT** (TO) package: $\theta_{(JA)} = 120 \text{ }^\circ\text{C/W}$, $\theta_{(JC)} = 18 \text{ }^\circ\text{C/W}$ **NDP** (PFM) package: $\theta_{(JA)} = 92 \text{ }^\circ\text{C/W}$, $\theta_{(JC)} = 10 \text{ }^\circ\text{C/W}$

LM341-5.0, LM78M05C ELECTRICAL CHARACTERISTICS

Unless otherwise specified: $V_{IN} = 10V$, $C_{IN} = 0.33 \mu\text{F}$, $C_O = 0.1 \mu\text{F}$

Limits in standard typeface are for $T_J = 25^\circ\text{C}$, and limits in **boldface type** apply over the -40°C to $+125^\circ\text{C}$ operating temperature range. Limits are specified by production testing or correlation techniques using standard Statistical Quality Control (SQC) methods.

Symbol	Parameter	Conditions	Min	Typ	Max	Units
V_O	Output Voltage	$I_L = 500 \text{ mA}$	4.8	5.0	5.2	V
		$5 \text{ mA} \leq I_L \leq 500 \text{ mA}$ $P_D \leq 7.5W$, $7.5V \leq V_{IN} \leq 20V$	4.75	5.0	5.25	
$V_{R \text{ LINE}}$	Line Regulation	$7.2V \leq V_{IN} \leq 25V$	$I_L = 100 \text{ mA}$		50	mV
			$I_L = 500 \text{ mA}$		100	
$V_{R \text{ LOAD}}$	Load Regulation	$5 \text{ mA} \leq I_L \leq 500 \text{ mA}$			100	
I_Q	Quiescent Current	$I_L = 500 \text{ mA}$		4	10.0	mA
ΔI_Q	Quiescent Current Change	$5 \text{ mA} \leq I_L \leq 500 \text{ mA}$			0.5	
		$7.5V \leq V_{IN} \leq 25V$, $I_L = 500 \text{ mA}$			1.0	
V_n	Output Noise Voltage	$f = 10 \text{ Hz to } 100 \text{ kHz}$		40		μV
$\Delta V_{IN}/\Delta V_O$	Ripple Rejection	$f = 120 \text{ Hz}$, $I_L = 500 \text{ mA}$		78		dB
V_{IN}	Input Voltage Required to Maintain Line Regulation	$I_L = 500 \text{ mA}$	7.2			V
ΔV_O	Long Term Stability	$I_L = 500 \text{ mA}$			20	mV/khrs

LM341-12, LM78M12C ELECTRICAL CHARACTERISTICS

Unless otherwise specified: $V_{IN} = 19V$, $C_{IN} = 0.33 \mu F$, $C_O = 0.1 \mu F$

Limits in standard typeface are for $T_J = 25^\circ C$, and limits in **boldface type** apply over the $-40^\circ C$ to $+125^\circ C$ operating temperature range. Limits are specified by production testing or correlation techniques using standard Statistical Quality Control (SQC) methods.

Symbol	Parameter	Conditions	Min	Typ	Max	Units
V_O	Output Voltage	$I_L = 500 \text{ mA}$	11.5	12	12.5	V
		$5 \text{ mA} \leq I_L \leq 500 \text{ mA}$ $P_D \leq 7.5W, 14.8V \leq V_{IN} \leq 27V$	11.4	12	12.6	
$V_{R \text{ LINE}}$	Line Regulation	$14.5V \leq V_{IN} \leq 30V$	$I_L = 100 \text{ mA}$		120	mV
			$I_L = 500 \text{ mA}$		240	
$V_{R \text{ LOAD}}$	Load Regulation	$5 \text{ mA} \leq I_L \leq 500 \text{ mA}$			240	
I_Q	Quiescent Current	$I_L = 500 \text{ mA}$		4	10.0	mA
ΔI_Q	Quiescent Current Change	$5 \text{ mA} \leq I_L \leq 500 \text{ mA}$			0.5	
		$14.8V \leq V_{IN} \leq 30V, I_L = 500 \text{ mA}$			1.0	
V_n	Output Noise Voltage	$f = 10 \text{ Hz to } 100 \text{ kHz}$		75		μV
$\Delta V_{IN}/\Delta V_O$	Ripple Rejection	$f = 120 \text{ Hz}, I_L = 500 \text{ mA}$		71		dB
V_{IN}	Input Voltage Required to Maintain Line Regulation	$I_L = 500 \text{ mA}$	14.5			V
ΔV_O	Long Term Stability	$I_L = 500 \text{ mA}$			48	mV/khrs

LM341-15, LM78M15C ELECTRICAL CHARACTERISTICS

Unless otherwise specified: $V_{IN} = 23V$, $C_{IN} = 0.33 \mu F$, $C_O = 0.1 \mu F$

Limits in standard typeface are for $T_J = 25^\circ C$, and limits in **boldface type** apply over the $-40^\circ C$ to $+125^\circ C$ operating temperature range. Limits are specified by production testing or correlation techniques using standard Statistical Quality Control (SQC) methods.

Symbol	Parameter	Conditions	Min	Typ	Max	Units
V_O	Output Voltage	$I_L = 500 \text{ mA}$	14.4	15	15.6	V
		$5 \text{ mA} \leq I_L \leq 500 \text{ mA}$ $P_D \leq 7.5W, 18V \leq V_{IN} \leq 30V$	14.25	15	15.75	
$V_{R \text{ LINE}}$	Line Regulation	$17.6V \leq V_{IN} \leq 30V$	$I_L = 100 \text{ mA}$		150	mV
			$I_L = 500 \text{ mA}$		300	
$V_{R \text{ LOAD}}$	Load Regulation	$5 \text{ mA} \leq I_L \leq 500 \text{ mA}$			300	
I_Q	Quiescent Current	$I_L = 500 \text{ mA}$		4	10.0	mA
ΔI_Q	Quiescent Current Change	$5 \text{ mA} \leq I_L \leq 500 \text{ mA}$			0.5	
		$18V \leq V_{IN} \leq 30V, I_L = 500 \text{ mA}$			1.0	
V_n	Output Noise Voltage	$f = 10 \text{ Hz to } 100 \text{ kHz}$		90		μV
$\Delta V_{IN}/\Delta V_O$	Ripple Rejection	$f = 120 \text{ Hz}, I_L = 500 \text{ mA}$		69		dB
V_{IN}	Input Voltage Required to Maintain Line Regulation	$I_L = 500 \text{ mA}$	17.6			V
ΔV_O	Long Term Stability	$I_L = 500 \text{ mA}$			60	mV/khrs

SCHMATIC DIAGRAM

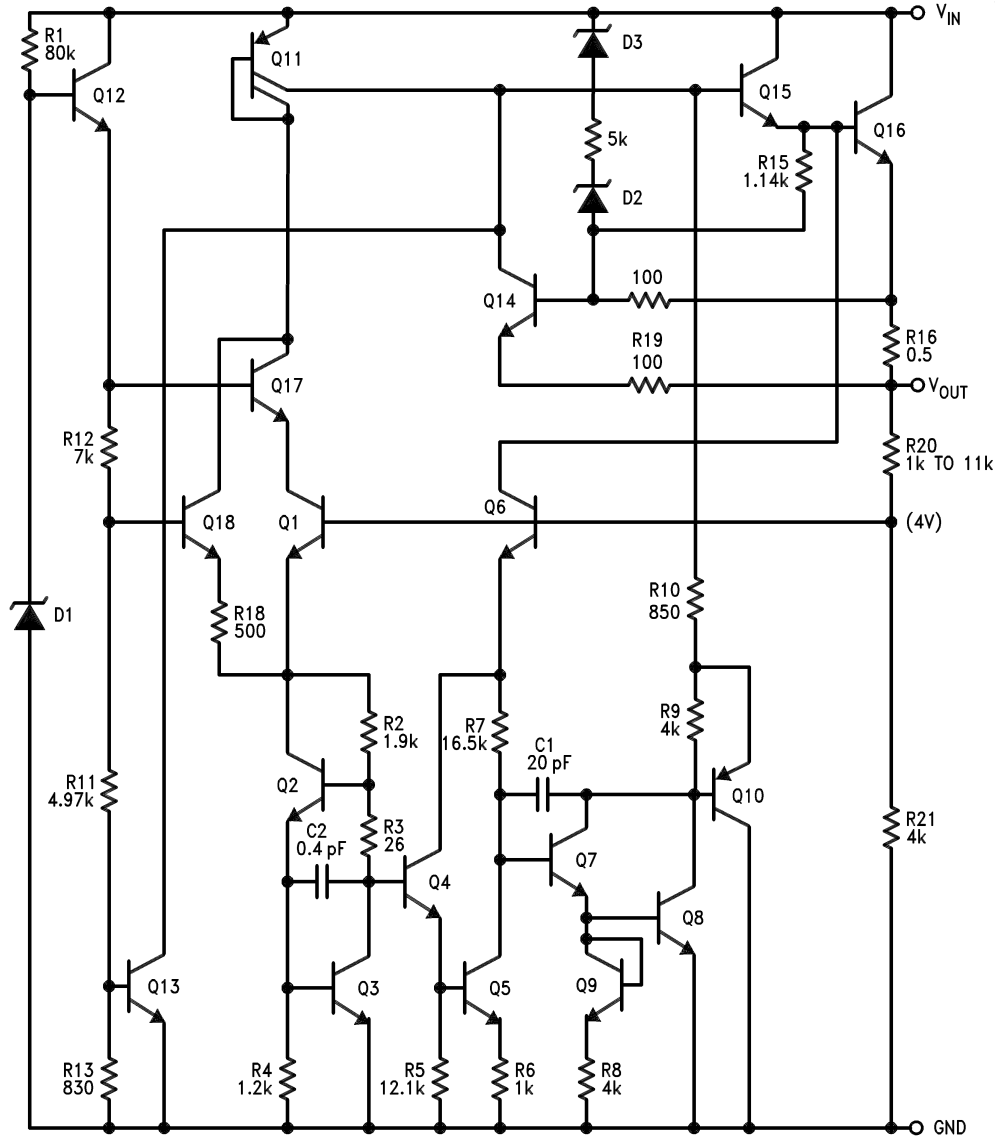

TYPICAL PERFORMANCE CHARACTERISTICS

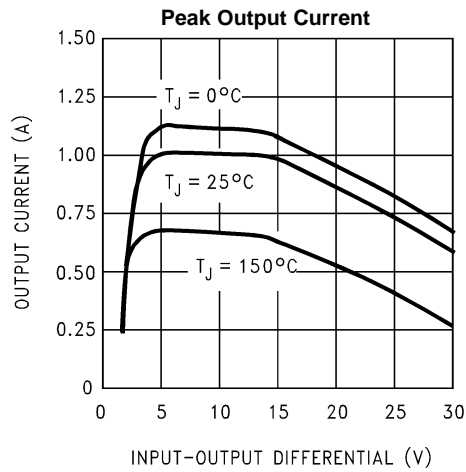

Figure 4.

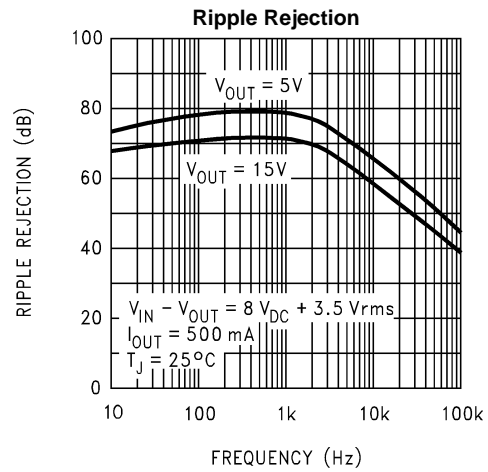

Figure 5.

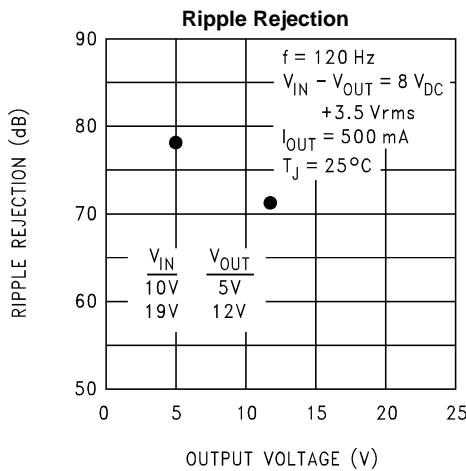

Figure 6.

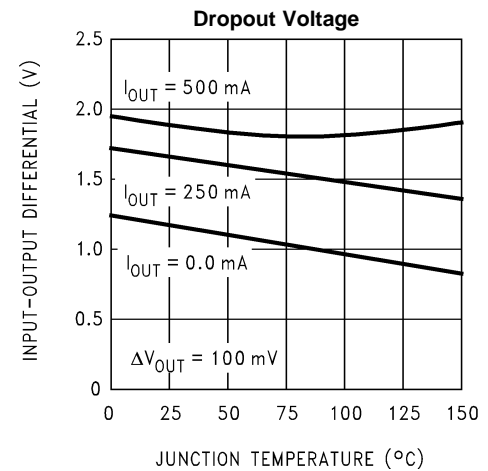

Figure 7.

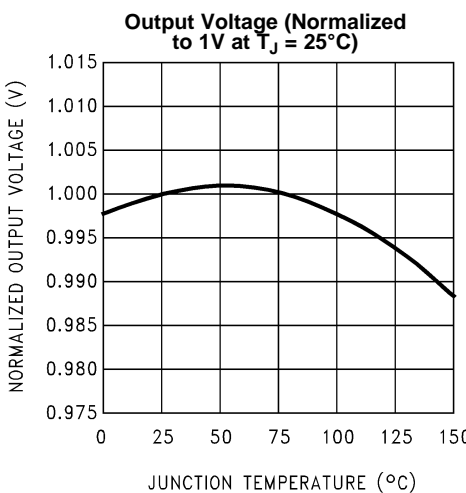

Figure 8.

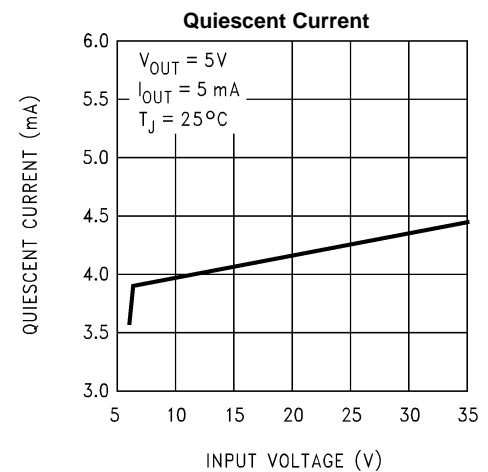

Figure 9.

TYPICAL PERFORMANCE CHARACTERISTICS (continued)

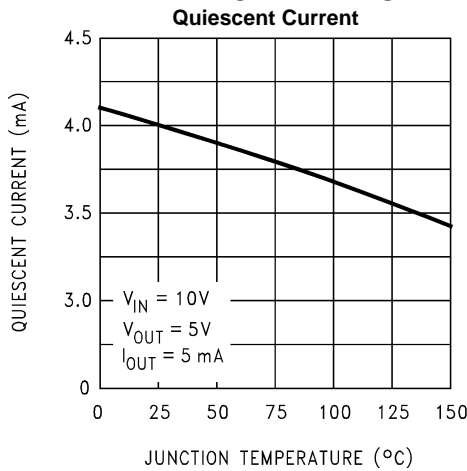

Figure 10.

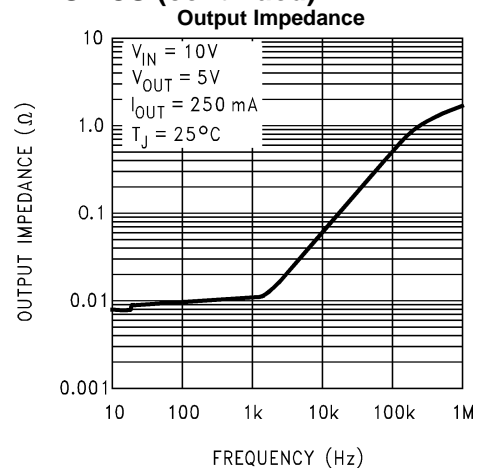

Figure 11.

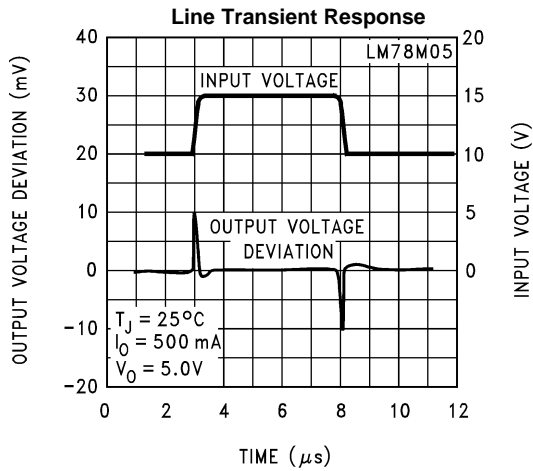

Figure 12.

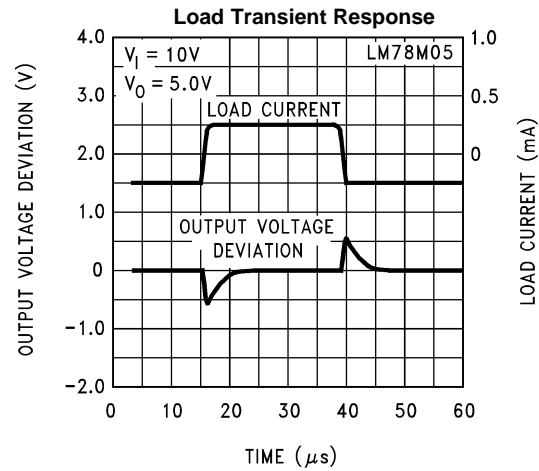

Figure 13.

DESIGN CONSIDERATIONS

The LM78MXX/LM341XX fixed voltage regulator series has built-in thermal overload protection which prevents the device from being damaged due to excessive junction temperature.

The regulators also contain internal short-circuit protection which limits the maximum output current, and safe-area protection for the pass transistor which reduces the short-circuit current as the voltage across the pass transistor is increased.

Although the internal power dissipation is automatically limited, the maximum junction temperature of the device must be kept below +125°C in order to meet data sheet specifications. An adequate heatsink should be provided to assure this limit is not exceeded under worst-case operating conditions (maximum input voltage and load current) if reliable performance is to be obtained).

HEATSINK CONSIDERATIONS

When an integrated circuit operates with appreciable current, its junction temperature is elevated. It is important to quantify its thermal limits in order to achieve acceptable performance and reliability. This limit is determined by summing the individual parts consisting of a series of temperature rises from the semiconductor junction to the operating environment. A one-dimension steady-state model of conduction heat transfer is demonstrated in [Figure 14](#). The heat generated at the device junction flows through the die to the die attach pad, through the lead frame to the surrounding case material, to the printed circuit board, and eventually to the ambient environment. Below is a list of variables that may affect the thermal resistance and in turn the need for a heatsink.

R_{θJC} (Component Variables)	R_{θCA} (Application Variables)
Leadframe Size & Material	Mounting Pad Size, Material, & Location
No. of Conduction Pins	Placement of Mounting Pad
Die Size	PCB Size & Material
Die Attach Material	Traces Length & Width
Molding Compound Size and Material	Adjacent Heat Sources
	Volume of Air
	Air Flow
	Ambient Temperature
	Shape of Mounting Pad

APPLICATION INFORMATION

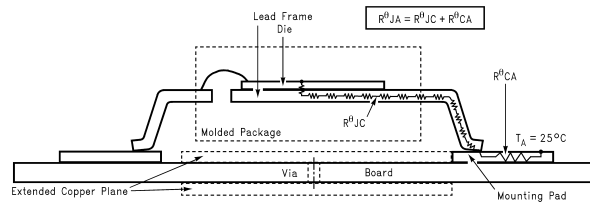

Note that the case temperature is measured at the point where the leads contact with the mounting pad surface

Figure 14. Cross-sectional view of Integrated Circuit Mounted on a printed circuit board.

The LM78MXX/LM341XX regulators have internal thermal shutdown to protect the device from over-heating. Under all possible operating conditions, the junction temperature of the LM78MXX/LM341XX must be within the range of 0°C to 125°C. A heatsink may be required depending on the maximum power dissipation and maximum ambient temperature of the application. To determine if a heatsink is needed, the power dissipated by the regulator, P_D , must be calculated:

$$I_{IN} = I_L + I_G \quad (1)$$

$$P_D = (V_{IN} - V_{OUT}) I_L + V_{IN} I_G \quad (2)$$

Figure 15 shows the voltages and currents which are present in the circuit.

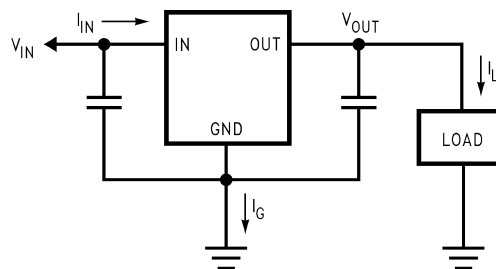

Figure 15. Power Dissipation Diagram

The next parameter which must be calculated is the maximum allowable temperature rise, $T_R(\max)$:

$$\theta_{JA} = T_R(\max) / P_D \quad (3)$$

If the maximum allowable value for θ_{JA} °C/W is found to be $\geq 60^\circ\text{C/W}$ for TO-220 package or $\geq 92^\circ\text{C/W}$ for PFM package, no heatsink is needed since the package alone will dissipate enough heat to satisfy these requirements. If the calculated value for θ_{JA} fall below these limits, a heatsink is required.

As a design aid, Table 1 shows the value of the θ_{JA} of PFM for different heatsink area. The copper patterns that we used to measure these θ_{JA} are shown at the end of the Application Note Section. Figure 16 reflects the same test results as what are in the Table 1

Figure 17 shows the maximum allowable power dissipation vs. ambient temperature for the TO-252 device. Figure 18 shows the maximum allowable power dissipation vs. copper area (in²) for the TO-252 device. Please see AN-1028 (SNVA036) for power enhancement techniques to be used with TO-252 package.

Table 1. θ_{JA} Different Heatsink Area

Layout	Copper Area		Thermal Resistance (θ_{JA} , °C/W) TO-252
	Top Side (in ²) ⁽¹⁾	Bottom Side (in ²)	
1	0.0123	0	103
2	0.066	0	87
3	0.3	0	60
4	0.53	0	54
5	0.76	0	52
6	1	0	47
7	0	0.2	84
8	0	0.4	70
9	0	0.6	63
10	0	0.8	57
11	0	1	57
12	0.066	0.066	89
13	0.175	0.175	72
14	0.284	0.284	61
15	0.392	0.392	55
16	0.5	0.5	53

(1) Tab of device attached to topside copper

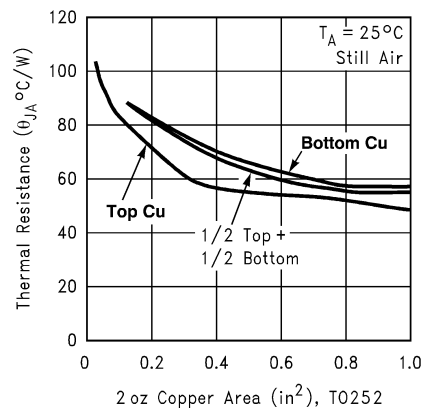

Figure 16. θ_{JA} vs. 2oz Copper Area for TO-252

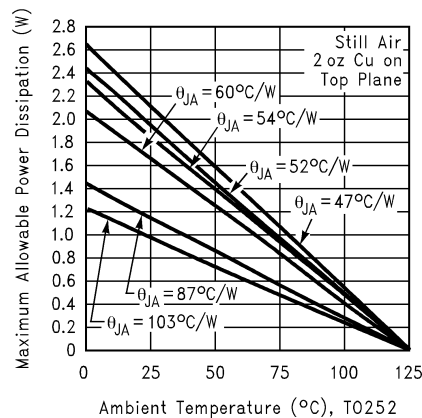

Figure 17. Maximum Allowable Power Dissipation vs. Ambient Temperature for TO-252

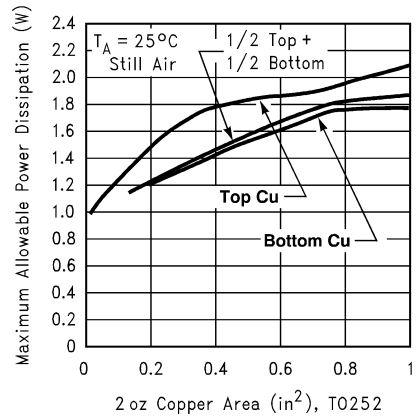
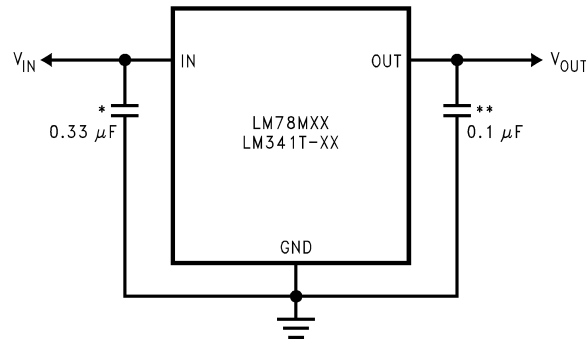

Figure 18. Maximum Allowable Power Dissipation vs. 2oz. Copper Area for TO-252

Typical Application



*Required if regulator input is more than 4 inches from input filter capacitor (or if no input filter capacitor is used).
 **Optional for improved transient response.

Figure 19. Typical Application

PACKAGING INFORMATION

Orderable Device	Status (1)	Package Type	Package Drawing	Pins	Package Qty	Eco Plan (2)	Lead/Ball Finish (6)	MSL Peak Temp (3)	Op Temp (°C)	Device Marking (4/5)	Samples
LM341T-15	NRND	TO-220	NDE	3	45	TBD	Call TI	Call TI	-40 to 125	LM341T-15 LM78M15CT	
LM341T-15/NOPB	ACTIVE	TO-220	NDE	3	45	Green (RoHS & no Sb/Br)	CU SN	Level-1-NA-UNLIM	-40 to 125	LM341T-15 LM78M15CT	Samples
LM341T-5.0	NRND	TO-220	NDE	3	45	TBD	Call TI	Call TI	-40 to 125	LM341T-5.0 LM78M05CT	
LM341T-5.0/NOPB	ACTIVE	TO-220	NDE	3	45	Green (RoHS & no Sb/Br)	CU SN	Level-1-NA-UNLIM	-40 to 125	LM341T-5.0 LM78M05CT	Samples
LM78M05CDT	NRND	TO-252	NDP	3	75	TBD	Call TI	Call TI	-40 to 125	LM78M05 CDT	
LM78M05CDT/NOPB	ACTIVE	TO-252	NDP	3	75	Green (RoHS & no Sb/Br)	CU SN	Level-2-260C-1 YEAR	-40 to 125	LM78M05 CDT	Samples
LM78M05CDTX	NRND	TO-252	NDP	3	2500	TBD	Call TI	Call TI	-40 to 125	LM78M05 CDT	
LM78M05CDTX/NOPB	ACTIVE	TO-252	NDP	3	2500	Green (RoHS & no Sb/Br)	CU SN	Level-2-260C-1 YEAR	-40 to 125	LM78M05 CDT	Samples
LM78M05CH	ACTIVE	TO	NDT	3	500	Green (RoHS & no Sb/Br)	AU	Level-1-NA-UNLIM	-40 to 125	LM78M05CH	Samples
LM78M05CH/NOPB	ACTIVE	TO	NDT	3	500	Green (RoHS & no Sb/Br)	AU	Level-1-NA-UNLIM	-40 to 125	LM78M05CH	Samples
LM78M05CT	NRND	TO-220	NDE	3	45	TBD	Call TI	Call TI	-40 to 125	LM341T-5.0 LM78M05CT	
LM78M05CT/NOPB	ACTIVE	TO-220	NDE	3	45	Green (RoHS & no Sb/Br)	CU SN	Level-1-NA-UNLIM	-40 to 125	LM341T-5.0 LM78M05CT	Samples

(1) The marketing status values are defined as follows:

ACTIVE: Product device recommended for new designs.

LIFEBUY: TI has announced that the device will be discontinued, and a lifetime-buy period is in effect.

NRND: Not recommended for new designs. Device is in production to support existing customers, but TI does not recommend using this part in a new design.

PREVIEW: Device has been announced but is not in production. Samples may or may not be available.

OBSELETE: TI has discontinued the production of the device.

(2) Eco Plan - The planned eco-friendly classification: Pb-Free (RoHS), Pb-Free (RoHS Exempt), or Green (RoHS & no Sb/Br) - please check <http://www.ti.com/productcontent> for the latest availability information and additional product content details.

TBD: The Pb-Free/Green conversion plan has not been defined.

Pb-Free (RoHS): TI's terms "Lead-Free" or "Pb-Free" mean semiconductor products that are compatible with the current RoHS requirements for all 6 substances, including the requirement that lead not exceed 0.1% by weight in homogeneous materials. Where designed to be soldered at high temperatures, TI Pb-Free products are suitable for use in specified lead-free processes.

Pb-Free (RoHS Exempt): This component has a RoHS exemption for either 1) lead-based flip-chip solder bumps used between the die and package, or 2) lead-based die adhesive used between the die and leadframe. The component is otherwise considered Pb-Free (RoHS compatible) as defined above.

Green (RoHS & no Sb/Br): TI defines "Green" to mean Pb-Free (RoHS compatible), and free of Bromine (Br) and Antimony (Sb) based flame retardants (Br or Sb do not exceed 0.1% by weight in homogeneous material)

⁽³⁾ MSL, Peak Temp. - The Moisture Sensitivity Level rating according to the JEDEC industry standard classifications, and peak solder temperature.

⁽⁴⁾ There may be additional marking, which relates to the logo, the lot trace code information, or the environmental category on the device.

⁽⁵⁾ Multiple Device Markings will be inside parentheses. Only one Device Marking contained in parentheses and separated by a "~" will appear on a device. If a line is indented then it is a continuation of the previous line and the two combined represent the entire Device Marking for that device.

⁽⁶⁾ Lead/Ball Finish - Orderable Devices may have multiple material finish options. Finish options are separated by a vertical ruled line. Lead/Ball Finish values may wrap to two lines if the finish value exceeds the maximum column width.

Important Information and Disclaimer:The information provided on this page represents TI's knowledge and belief as of the date that it is provided. TI bases its knowledge and belief on information provided by third parties, and makes no representation or warranty as to the accuracy of such information. Efforts are underway to better integrate information from third parties. TI has taken and continues to take reasonable steps to provide representative and accurate information but may not have conducted destructive testing or chemical analysis on incoming materials and chemicals. TI and TI suppliers consider certain information to be proprietary, and thus CAS numbers and other limited information may not be available for release.

In no event shall TI's liability arising out of such information exceed the total purchase price of the TI part(s) at issue in this document sold by TI to Customer on an annual basis.

TAPE AND REEL INFORMATION



QUADRANT ASSIGNMENTS FOR PIN 1 ORIENTATION IN TAPE



*All dimensions are nominal

Device	Package Type	Package Drawing	Pins	SPQ	Reel Diameter (mm)	Reel Width W1 (mm)	A0 (mm)	B0 (mm)	K0 (mm)	P1 (mm)	W (mm)	Pin1 Quadrant
LM78M05CDTX	TO-252	NDP	3	2500	330.0	16.4	6.9	10.5	2.7	8.0	16.0	Q2
LM78M05CDTX/NOPB	TO-252	NDP	3	2500	330.0	16.4	6.9	10.5	2.7	8.0	16.0	Q2

TAPE AND REEL BOX DIMENSIONS



*All dimensions are nominal

Device	Package Type	Package Drawing	Pins	SPQ	Length (mm)	Width (mm)	Height (mm)
LM78M05CDTX	TO-252	NDP	3	2500	367.0	367.0	35.0
LM78M05CDTX/NOPB	TO-252	NDP	3	2500	367.0	367.0	38.0

NDT0003A

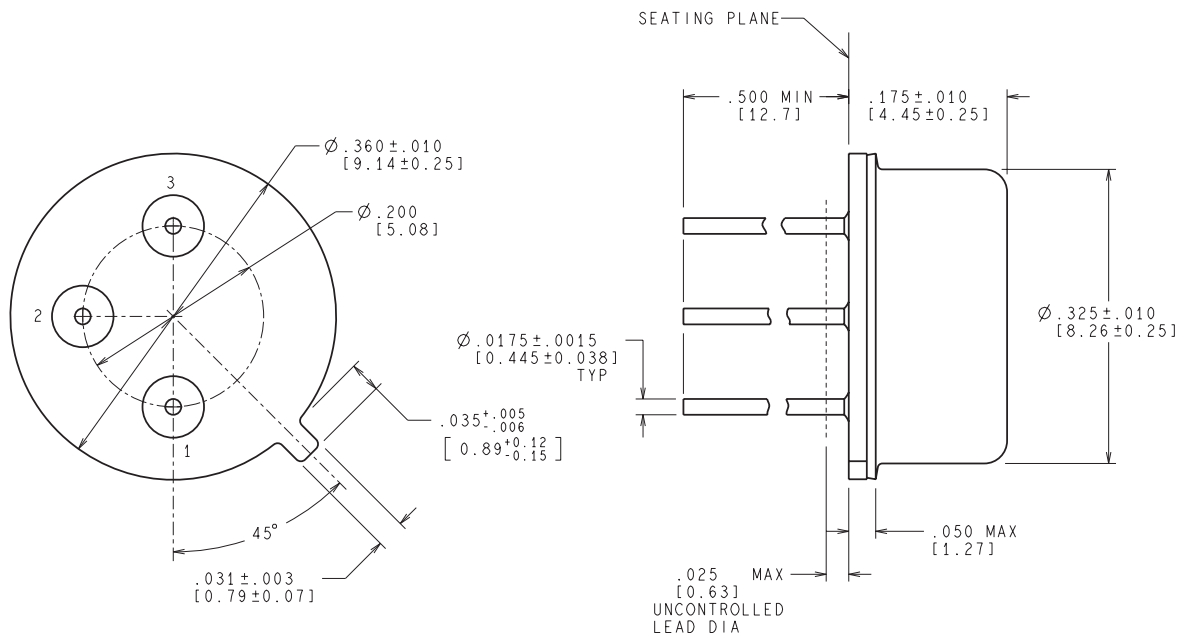

CONTROLLING DIMENSION IS INCH
VALUES IN [] ARE MILLIMETERS

MIL-PRF-38535
CONFIGURATION CONTROL

H03A (Rev D)

NDE0003B

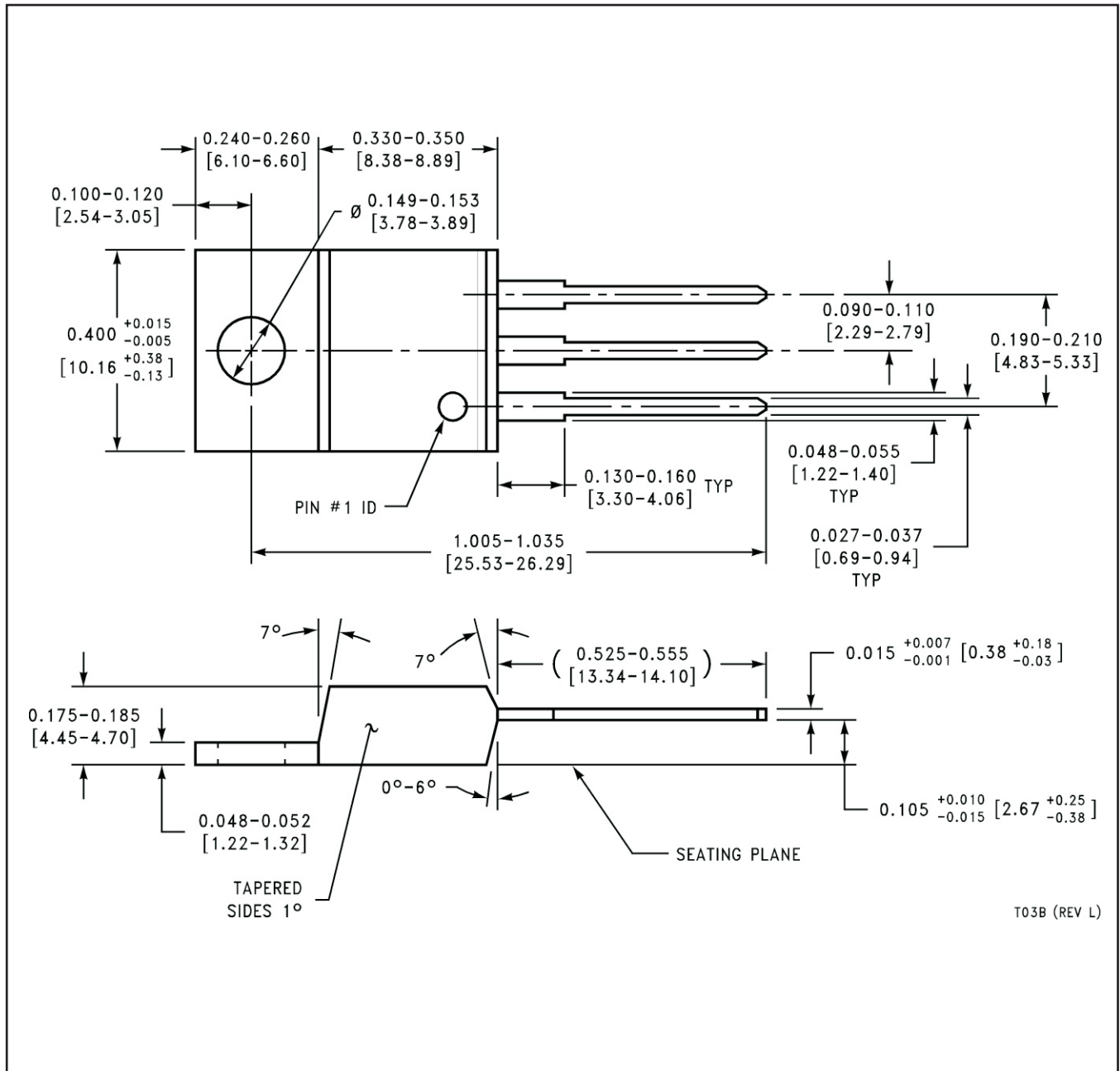

NDP0003B

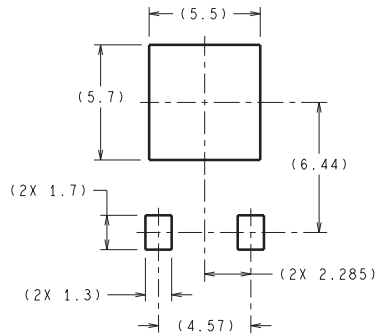

DIMENSIONS ARE IN MILLIMETERS
DIMENSIONS IN () FOR REFERENCE ONLY

LAND PATTERN RECOMMENDATION

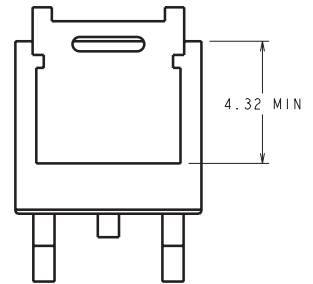
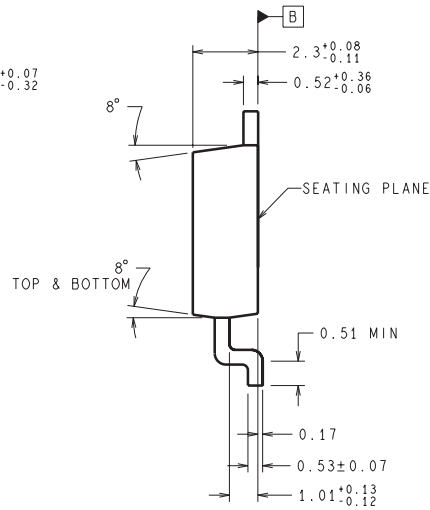
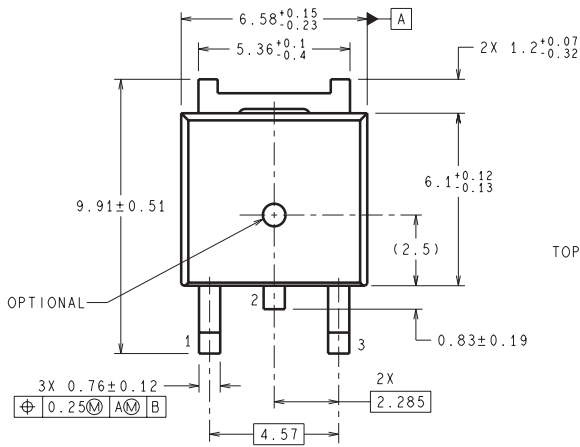

TD03B (Rev F)

IMPORTANT NOTICE

Texas Instruments Incorporated and its subsidiaries (TI) reserve the right to make corrections, enhancements, improvements and other changes to its semiconductor products and services per JESD46, latest issue, and to discontinue any product or service per JESD48, latest issue. Buyers should obtain the latest relevant information before placing orders and should verify that such information is current and complete. All semiconductor products (also referred to herein as "components") are sold subject to TI's terms and conditions of sale supplied at the time of order acknowledgment.

TI warrants performance of its components to the specifications applicable at the time of sale, in accordance with the warranty in TI's terms and conditions of sale of semiconductor products. Testing and other quality control techniques are used to the extent TI deems necessary to support this warranty. Except where mandated by applicable law, testing of all parameters of each component is not necessarily performed.

TI assumes no liability for applications assistance or the design of Buyers' products. Buyers are responsible for their products and applications using TI components. To minimize the risks associated with Buyers' products and applications, Buyers should provide adequate design and operating safeguards.

TI does not warrant or represent that any license, either express or implied, is granted under any patent right, copyright, mask work right, or other intellectual property right relating to any combination, machine, or process in which TI components or services are used. Information published by TI regarding third-party products or services does not constitute a license to use such products or services or a warranty or endorsement thereof. Use of such information may require a license from a third party under the patents or other intellectual property of the third party, or a license from TI under the patents or other intellectual property of TI.

Reproduction of significant portions of TI information in TI data books or data sheets is permissible only if reproduction is without alteration and is accompanied by all associated warranties, conditions, limitations, and notices. TI is not responsible or liable for such altered documentation. Information of third parties may be subject to additional restrictions.

Resale of TI components or services with statements different from or beyond the parameters stated by TI for that component or service voids all express and any implied warranties for the associated TI component or service and is an unfair and deceptive business practice. TI is not responsible or liable for any such statements.

Buyer acknowledges and agrees that it is solely responsible for compliance with all legal, regulatory and safety-related requirements concerning its products, and any use of TI components in its applications, notwithstanding any applications-related information or support that may be provided by TI. Buyer represents and agrees that it has all the necessary expertise to create and implement safeguards which anticipate dangerous consequences of failures, monitor failures and their consequences, lessen the likelihood of failures that might cause harm and take appropriate remedial actions. Buyer will fully indemnify TI and its representatives against any damages arising out of the use of any TI components in safety-critical applications.

In some cases, TI components may be promoted specifically to facilitate safety-related applications. With such components, TI's goal is to help enable customers to design and create their own end-product solutions that meet applicable functional safety standards and requirements. Nonetheless, such components are subject to these terms.

No TI components are authorized for use in FDA Class III (or similar life-critical medical equipment) unless authorized officers of the parties have executed a special agreement specifically governing such use.

Only those TI components which TI has specifically designated as military grade or "enhanced plastic" are designed and intended for use in military/aerospace applications or environments. Buyer acknowledges and agrees that any military or aerospace use of TI components which have **not** been so designated is solely at the Buyer's risk, and that Buyer is solely responsible for compliance with all legal and regulatory requirements in connection with such use.

TI has specifically designated certain components as meeting ISO/TS16949 requirements, mainly for automotive use. In any case of use of non-designated products, TI will not be responsible for any failure to meet ISO/TS16949.

Products

Audio	www.ti.com/audio
Amplifiers	amplifier.ti.com
Data Converters	dataconverter.ti.com
DLP® Products	www.dlp.com
DSP	dsp.ti.com
Clocks and Timers	www.ti.com/clocks
Interface	interface.ti.com
Logic	logic.ti.com
Power Mgmt	power.ti.com
Microcontrollers	microcontroller.ti.com
RFID	www.ti-rfid.com
OMAP Applications Processors	www.ti.com/omap
Wireless Connectivity	www.ti.com/wirelessconnectivity

Applications

Automotive and Transportation	www.ti.com/automotive
Communications and Telecom	www.ti.com/communications
Computers and Peripherals	www.ti.com/computers
Consumer Electronics	www.ti.com/consumer-apps
Energy and Lighting	www.ti.com/energy
Industrial	www.ti.com/industrial
Medical	www.ti.com/medical
Security	www.ti.com/security
Space, Avionics and Defense	www.ti.com/space-avionics-defense
Video and Imaging	www.ti.com/video

TI E2E Community

e2e.ti.com