

LMC6024 Low Power CMOS Quad Operational Amplifier

 Check for Samples: [LMC6024](#)

FEATURES

- Specified for 100 k Ω and 5 k Ω Loads
- High Voltage Gain 120 dB
- Low Offset Voltage Drift 2.5 $\mu\text{V}/^\circ\text{C}$
- Ultra Low Input Bias Current 40 fA
- Input Common-mode Range Includes V^-
- Operating Range from +5V to +15V Supply
- Low Distortion 0.01% at 1 kHz
- Slew Rate 0.11 V/ μs
- Micropower Operation 1 mW

APPLICATIONS

- High-impedance Buffer or Preamplifier
- Current-to-voltage Converter
- Long-term Integrator
- Sample-and-hold Circuit
- Peak Detector
- Medical Instrumentation
- Industrial Controls

Connection Diagram

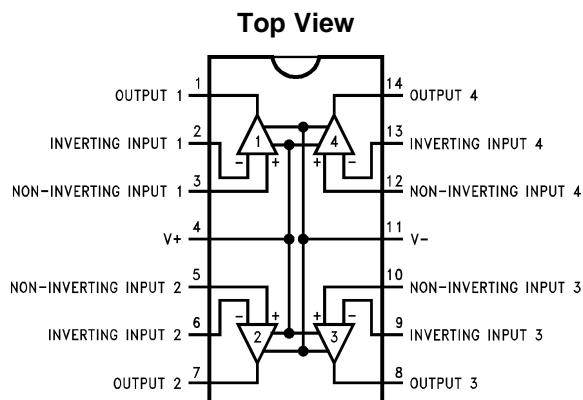

Figure 1. 14-Pin DIP and SOIC Package
See Package Number D0014A



These devices have limited built-in ESD protection. The leads should be shorted together or the device placed in conductive foam during storage or handling to prevent electrostatic damage to the MOS gates.



Please be aware that an important notice concerning availability, standard warranty, and use in critical applications of Texas Instruments semiconductor products and disclaimers thereto appears at the end of this data sheet.

All trademarks are the property of their respective owners.

Absolute Maximum Ratings ⁽¹⁾⁽²⁾

Differential Input Voltage		±Supply Voltage
Supply Voltage (V ⁺ - V ⁻)		16V
Lead Temperature	Soldering, 10 sec.	260°C
Storage Temperature Range		-65°C to +150°C
Voltage at Output/Input Pin		(V ⁺) + 0.3V, (V ⁻) - 0.3V
Current at Input Pin		±5 mA
Current at Output Pin		±18 mA
Current at Power Supply Pin		35 mA
Output Short Circuit to V ⁺		See ⁽³⁾
Output Short Circuit to V ⁻		See ⁽⁴⁾
Junction Temperature		150°C
ESD Tolerance ⁽⁵⁾		1000V
Power Dissipation		See ⁽⁶⁾

- (1) Absolute Maximum Ratings indicate limits beyond which damage to the component may occur. Operating Ratings indicate conditions for which the device is intended to be functional, but do not guarantee specific performance limits. For guaranteed specifications and test conditions, see the Electrical Characteristics. The guaranteed specifications apply only for the test conditions listed.
- (2) If Military/Aerospace specified devices are required, please contact the Texas Instruments Sales Office/ Distributors for availability and specifications.
- (3) Do not connect output to V⁺ when V⁺ is greater than 13V or reliability may be adversely affected.
- (4) Applies to both single-supply and split-supply operation. Continuous short circuit operation at elevated ambient temperature and/or multiple Op Amp shorts can result in exceeding the maximum allowed junction temperature of 150°C. Output currents in excess of ±30 mA over long term may adversely affect reliability.
- (5) Human body model, 100 pF discharge through a 1.5 kΩ resistor.
- (6) The maximum power dissipation is a function of T_{J(max)}, θ_{JA}, and T_A. The maximum allowable power dissipation at any ambient temperature is P_D = (T_{J(max)} - T_A)/θ_{JA}.

Operating Ratings

Temperature Range		-40°C ≤ T _J ≤ +85°C
Supply Voltage Range		4.75V to 15.5V
Power Dissipation		See ⁽¹⁾
Thermal Resistance (θ _{JA}) ⁽²⁾	14-Pin DIP	85°C/W
	14-Pin SOIC	115°C/W

- (1) For operating at elevated temperatures the device must be derated based on the thermal resistance θ_{JA} with P_D = (T_J - T_A)/θ_{JA}.
- (2) All numbers apply for packages soldered directly into a PC board.

DC Electrical Characteristics

The following specifications apply for $V^+ = 5V$, $V^- = 0V$, $V_{CM} = 1.5V$, $V_O = 2.5V$, and $R_L = 1M$ unless otherwise noted.

Boldface limits apply at the temperature extremes; all other limits $T_J = 25^\circ C$.

Parameter		Test Conditions		Typical ⁽¹⁾	LMC6024I Limit ⁽²⁾	Units		
V_{OS}	Input Offset Voltage			1	9	mV		
					11	Max		
$\Delta V_{OS}/\Delta T$	Input Offset Voltage Average Drift			2.5		$\mu V/^\circ C$		
I_B	Input Bias Current			0.04		pA		
					200	Max		
I_{OS}	Input Offset Current			0.01	100	pA Max		
R_{IN}	Input Resistance			>1		Tera Ω		
CMRR	Common Mode Rejection Ratio	$0V \leq V_{CM} \leq 12V$		83	63	dB Min		
		$V^+ = 15V$			61			
+PSRR	Positive Power Supply Rejection Ratio	$5V \leq V^+ \leq 15V$		83	63	dB Min		
					61			
-PSRR	Negative Power Supply Rejection Ratio	$0V \leq V^- \leq -10V$		94	74	dB Min		
					73			
V_{CM}	Input Common-Mode Voltage Range	$V^+ = 5V$ and $15V$ For CMRR ≥ 50 DB		-0.4	-0.1	V Max		
					0			
				$V^+ - 1.9$	$V^+ - 2.3$	V Min		
					$V^+ - 2.5$			
A_V	Large Signal Voltage Gain	$R_L = 100\text{ k}\Omega^{(3)}$	Sourcing	1000	200	V/mV Min		
					100			
			Sinking	500	90	V/mV Min		
					40			
		$R_L = 5\text{ k}\Omega^{(3)}$	Sourcing	1000	100	V/mV Min		
					75			
			Sinking	250	50	V/mV Min		
					20			
V_O	Output Voltage Swing	$V^+ = 5V$ $R_L = 100\text{ k}\Omega$ to $2.5V$		4.987	4.40	V Min		
					4.43			
				0.004	0.06	V Max		
					0.09			
				$V^+ = 5V$ $R_L = 5\text{ k}\Omega$ to $2.5V$		4.940	4.20	V Min
							4.00	
		0.040	0.25			V Max		
			0.35					
		$V^+ = 15V$ $R_L = 100\text{ k}\Omega$ to $7.5V$		14.970	14.00	V Min		
					13.90			
				0.007	0.06	V Max		
					0.09			
$V^+ = 15V$ $R_L = 5\text{ k}\Omega$ to $7.5V$		14.840	13.70	V Min				
			13.50					
		0.110	0.32	V Max				
			0.40					

(1) Typical values represent the most likely parametric norm.

(2) All limits are guaranteed by testing or correlation.

(3) $V^+ = 15V$, $V_{CM} = 7.5V$, and R_L connected to $7.5V$. For Sourcing tests, $7.5V \leq V_O \leq 11.5V$. For Sinking tests, $2.5V \leq V_O \leq 7.5V$.

DC Electrical Characteristics (continued)

The following specifications apply for $V^+ = 5V$, $V^- = 0V$, $V_{CM} = 1.5V$, $V_O = 2.5V$, and $R_L = 1M$ unless otherwise noted.

Boldface limits apply at the temperature extremes; all other limits $T_J = 25^\circ C$.

Parameter		Test Conditions	Typical ⁽¹⁾	LMC6024I Limit ⁽²⁾	Units
I_O	Output Current	$V^+ = 5V$ Sourcing, $V_O = 0V$ Sinking $V_O = 5V$ ⁽⁴⁾	22	13	mA Min
				9	
			21	13	mA Min
				9	
		$V^+ = 15V$ Sourcing, $V_O = 0V$ Sinking, $V_O = 13V$ ⁽⁵⁾	40	23	mA Min
				15	
		39	23	mA Min	
			15		
I_S	Supply Current	All Four Amplifiers $V_O = 1.5V$	160	240	μA Max
				280	

(4) Applies to both single-supply and split-supply operation. Continuous short circuit operation at elevated ambient temperature and/or multiple Op Amp shorts can result in exceeding the maximum allowed junction temperature of $150^\circ C$. Output currents in excess of ± 30 mA over long term may adversely affect reliability.

(5) Do not connect output to V^+ when V^+ is greater than 13V or reliability may be adversely affected.

AC Electrical Characteristics

The following specifications apply for $V^+ = 5V$, $V^- = 0V$, $V_{CM} = 1.5V$, $V_O = 2.5V$, and $R_L = 1M$ unless otherwise noted.

Boldface limits apply at the temperature extremes; all other limits $T_J = 25^\circ C$.

Parameter		Test Conditions	Typical ⁽¹⁾	LMC6024I Limit ⁽²⁾	Units
SR	Slew Rate	See ⁽³⁾	0.11	0.05	V/ μs Min
				0.03	
GBW	Gain-Bandwidth Product		0.35		MHz
θ_M	Phase Margin		50		Deg
G_M	Gain Margin		17		dB
	Amp-to-Amp Isolation	See ⁽⁴⁾	130		dB
e_n	Input-Referred Voltage Noise	$F = 1$ kHz	42		nV/ \sqrt{Hz}
i_n	Input-Referred Current Noise	$F = 1$ kHz	0.0002		pA/ \sqrt{Hz}

(1) Typical values represent the most likely parametric norm.

(2) All limits are guaranteed by testing or correlation.

(3) $V^+ = 15V$. Connected as Voltage Follower with 10V step input. Number specified is the slower of the positive and negative slew rates.

(4) Input referred, $V^+ = 15V$ and $R_L = 100$ k Ω connected to 7.5V. Each amp excited in turn with 1 kHz to produce $V_O = 13$ V_{PP}.

Typical Performance Characteristics

$V_S = \pm 7.5V$, $T_A = 25^\circ C$ unless otherwise specified

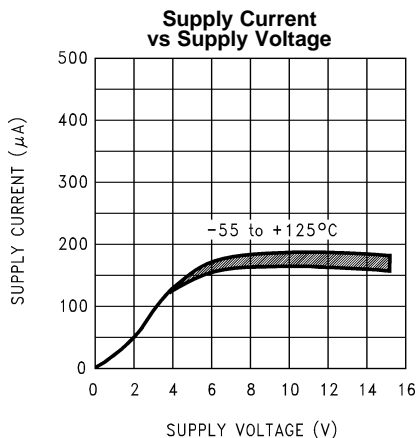

Figure 2.

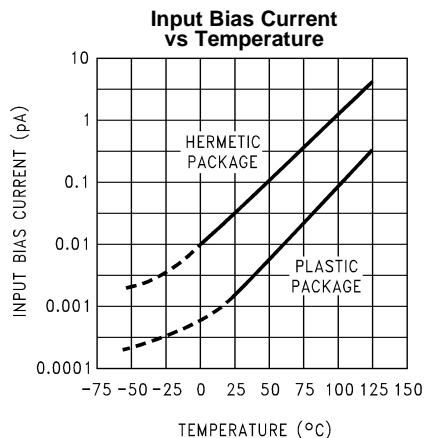

Figure 3.

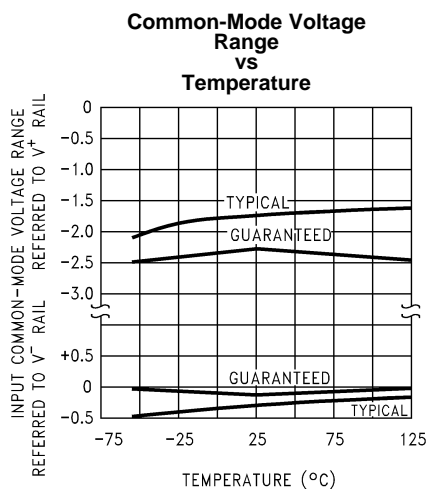

Figure 4.

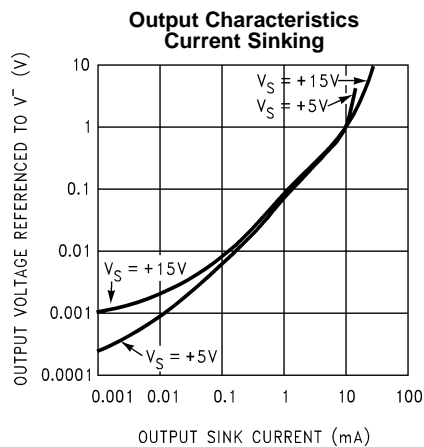

Figure 5.

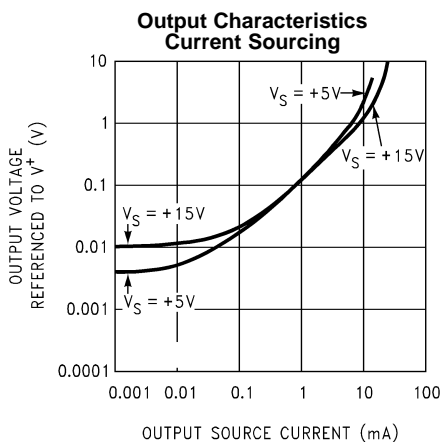

Figure 6.

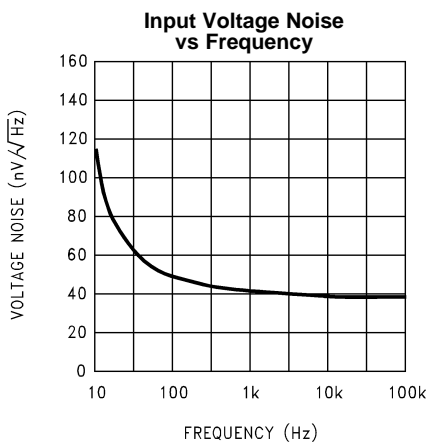

Figure 7.

Typical Performance Characteristics (continued)

$V_S = \pm 7.5V$, $T_A = 25^\circ C$ unless otherwise specified

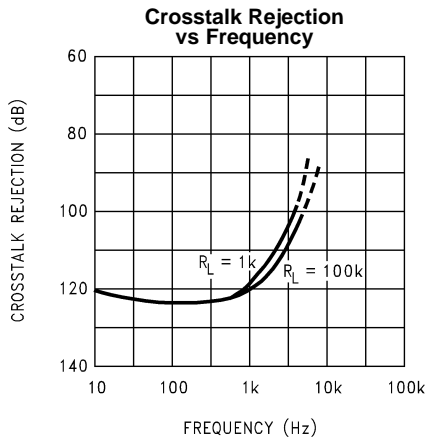

Figure 8.

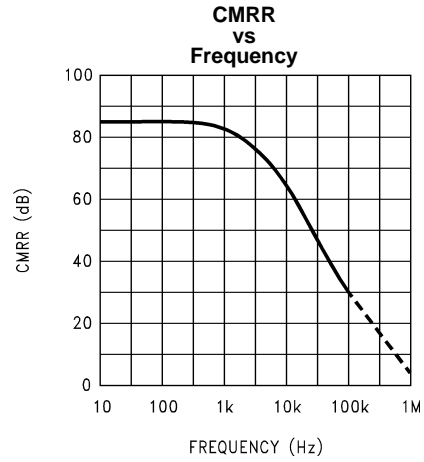

Figure 9.

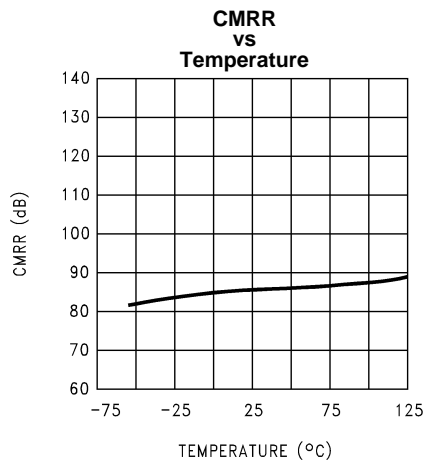

Figure 10.

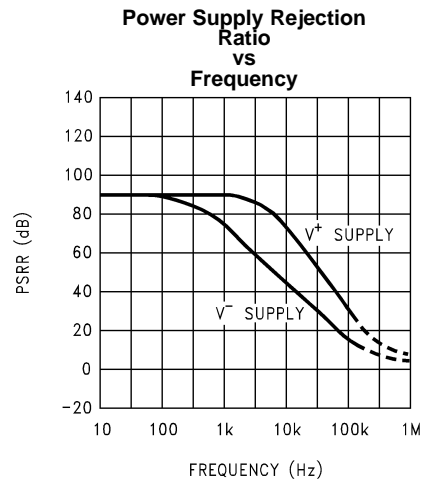

Figure 11.

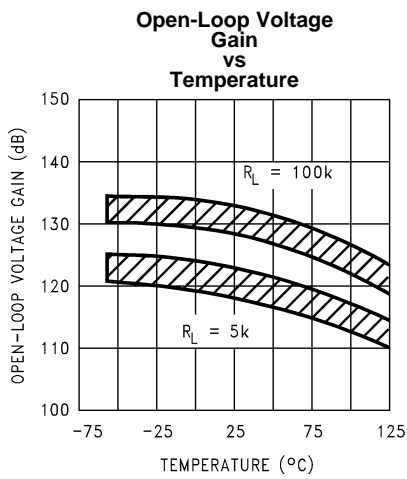

Figure 12.

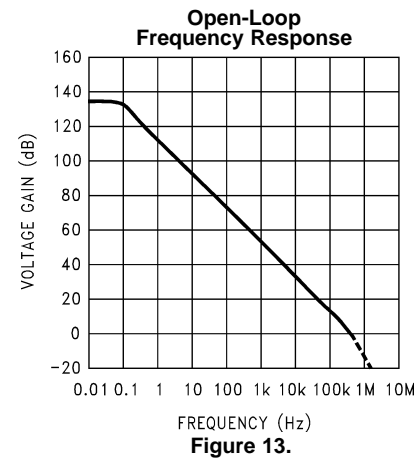

Figure 13.

Typical Performance Characteristics (continued)

$V_S = \pm 7.5V$, $T_A = 25^\circ C$ unless otherwise specified

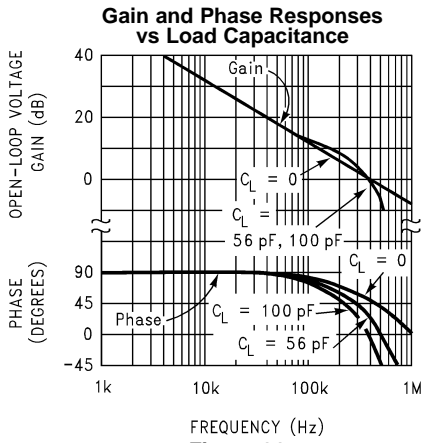

Figure 14.

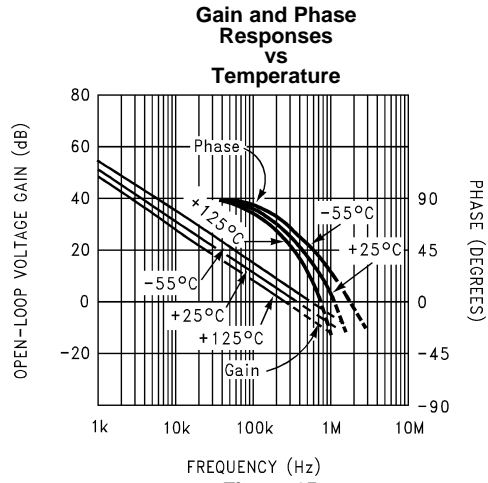

Figure 15.

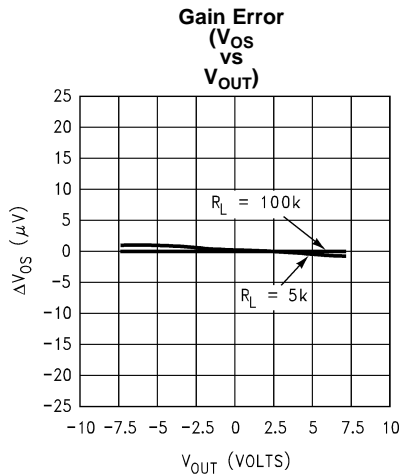

Figure 16.

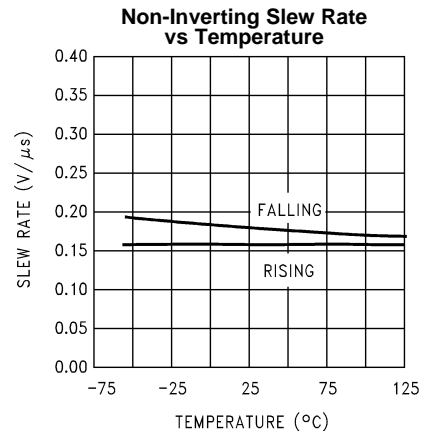

Figure 17.

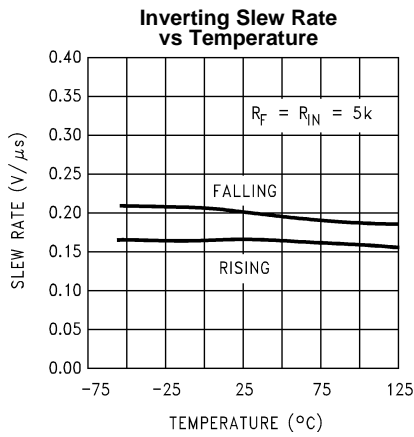

Figure 18.

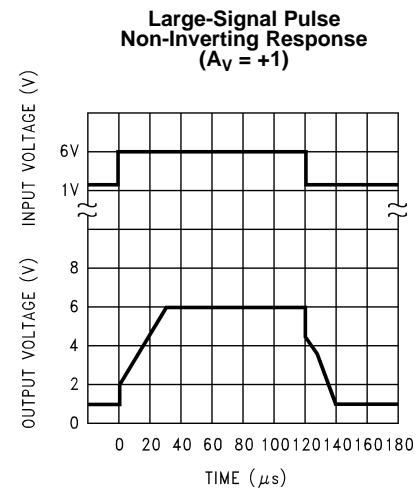

Figure 19.

Typical Performance Characteristics (continued)

$V_S = \pm 7.5V$, $T_A = 25^\circ C$ unless otherwise specified

Non-Inverting Small Signal Pulse Response ($A_V = +1$)

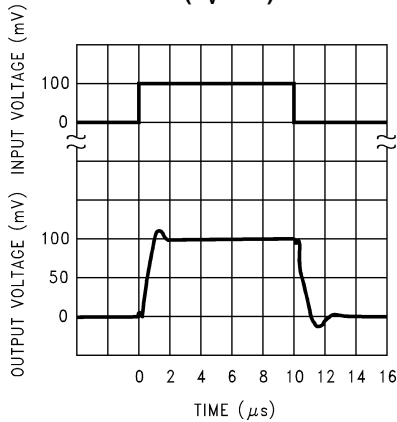

Figure 20.

Inverting Large-Signal Pulse Response

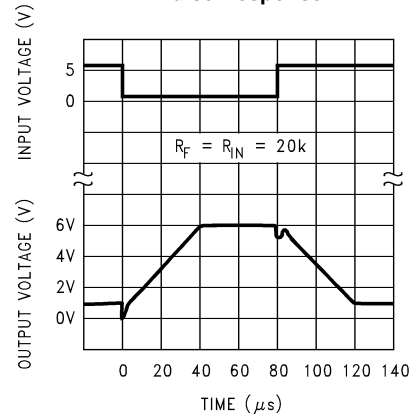

Figure 21.

Inverting Small-Signal Pulse Response

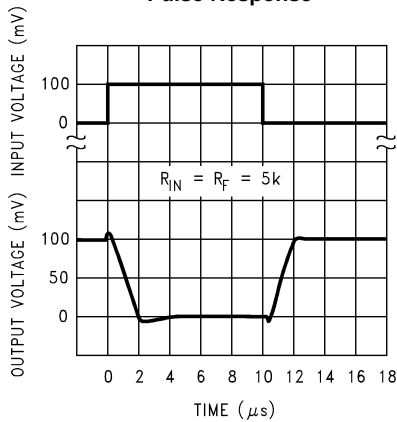
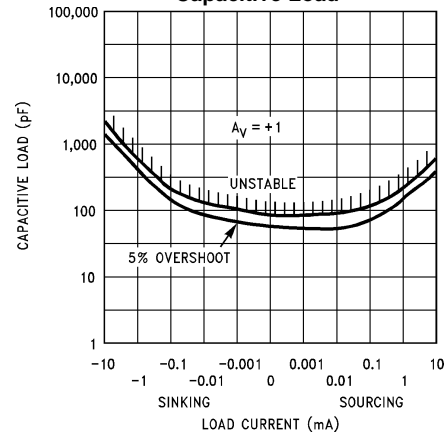

Figure 22.

Stability vs Capacitive Load



Avoid resistive loads of less than 500Ω , as they may cause instability.

Figure 23.

Stability vs Capacitive Load

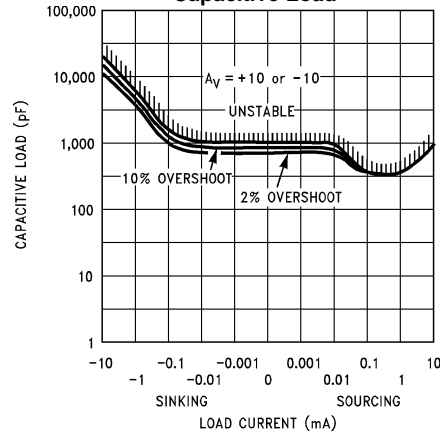

Figure 24.

APPLICATION HINTS

AMPLIFIER TOPOLOGY

The topology chosen for the LMC6024 is unconventional (compared to general-purpose op amps) in that the traditional unity-gain buffer output stage is not used; instead, the output is taken directly from the output of the integrator, to allow rail-to-rail output swing. Since the buffer traditionally delivers the power to the load, while maintaining high op amp gain and stability, and must withstand shorts to either rail, these tasks now fall to the integrator.

As a result of these demands, the integrator is a compound affair with an embedded gain stage that is doubly fed forward (via C_f and C_{ff}) by a dedicated unity-gain compensation driver. In addition, the output portion of the integrator is a push-pull configuration for delivering heavy loads. While sinking current the whole amplifier path consists of three gain stages with one stage fed forward, whereas while sourcing the path contains four gain stages with two fed forward.

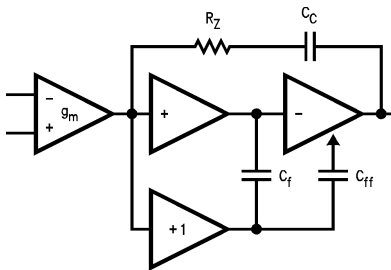

Figure 25. LMC6024 Circuit Topology (Each Amplifier)

The large signal voltage gain while sourcing is comparable to traditional bipolar op amps, for load resistance of at least 5 k Ω . The gain while sinking is higher than most CMOS op amps, due to the additional gain stage; however, when driving load resistance of 5 k Ω or less, the gain will be reduced as indicated in the Electrical Characteristics. The op amp can drive load resistance as low as 500 Ω without instability.

COMPENSATING INPUT CAPACITANCE

Refer to the LMC660 or LMC662 datasheets to determine whether or not a feedback capacitor will be necessary for compensation and what the value of that capacitor would be.

CAPACITIVE LOAD TOLERANCE

Like many other op amps, the LMC6024 may oscillate when its applied load appears capacitive. The threshold of oscillation varies both with load and circuit gain. The configuration most sensitive to oscillation is a unity-gain follower. See the [Typical Performance Characteristics](#).

The load capacitance interacts with the op amp's output resistance to create an additional pole. If this pole frequency is sufficiently low, it will degrade the op amp's phase margin so that the amplifier is no longer stable at low gains. The addition of a small resistor (50 Ω to 100 Ω) in series with the op amp's output, and a capacitor (5 pF to 10 pF) from inverting input to output pins, returns the phase margin to a safe value without interfering with lower-frequency circuit operation. Thus, larger values of capacitance can be tolerated without oscillation. Note that in all cases, the output will ring heavily when the load capacitance is near the threshold for oscillation.

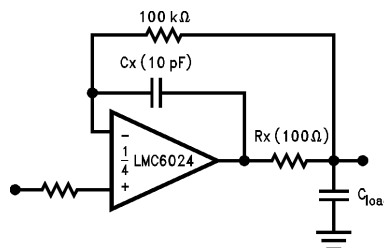

Figure 26. Rx, Cx Improve Capacitive Load Tolerance

Capacitive load driving capability is enhanced by using a pull up resistor to V^+ (Figure 27). Typically a pull up resistor conducting $50\ \mu\text{A}$ or more will significantly improve capacitive load responses. The value of the pull up resistor must be determined based on the current sinking capability of the amplifier with respect to the desired output swing. Open loop gain of the amplifier can also be affected by the pull up resistor (see [DC Electrical Characteristics](#)).

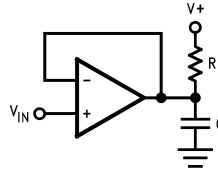

Figure 27. Compensating for Large Capacitive Loads with a Pull Up Resistor

PRINTED-CIRCUIT-BOARD LAYOUT FOR HIGH-IMPEDANCE WORK

It is generally recognized that any circuit which must operate with less than $1000\ \text{pA}$ of leakage current requires special layout of the PC board. When one wishes to take advantage of the ultra-low bias current of the LMC6024, typically less than $0.04\ \text{pA}$, it is essential to have an excellent layout. Fortunately, the techniques for obtaining low leakages are quite simple. First, the user must not ignore the surface leakage of the PC board, even though it may sometimes appear acceptably low, because under conditions of high humidity or dust or contamination, the surface leakage will be appreciable.

To minimize the effect of any surface leakage, lay out a ring of foil completely surrounding the LMC6024's inputs and the terminals of capacitors, diodes, conductors, resistors, relay terminals, etc. connected to the op-amp's inputs. See Figure 28. To have a significant effect, guard rings should be placed on both the top and bottom of the PC board. This PC foil must then be connected to a voltage which is at the same voltage as the amplifier inputs, since no leakage current can flow between two points at the same potential. For example, a PC board trace-to-pad resistance of 10^{12} ohms, which is normally considered a very large resistance, could leak $5\ \text{pA}$ if the trace were a 5V bus adjacent to the pad of an input. This would cause a 100 times degradation from the LMC6024's actual performance. However, if a guard ring is held within $5\ \text{mV}$ of the inputs, then even a resistance of 10^{11} ohms would cause only $0.05\ \text{pA}$ of leakage current, or perhaps a minor (2:1) degradation of the amplifier's performance. See Figure 28, Figure 30, and Figure 31 for typical connections of guard rings for standard op-amp configurations. If both inputs are active and at high impedance, the guard can be tied to ground and still provide some protection; see Figure 32.

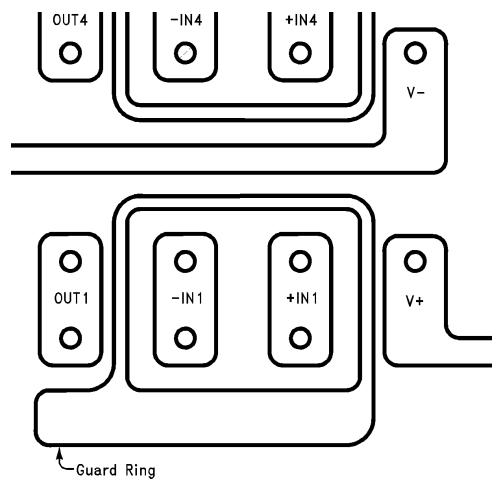

Figure 28. Example of Guard Ring in P.C. Board Layout (Using the LMC6024)

Guard Ring Connections

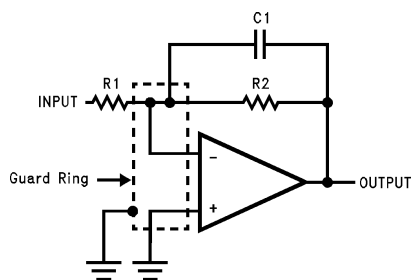

Figure 29. Inverting Amplifier Guard Ring Connections

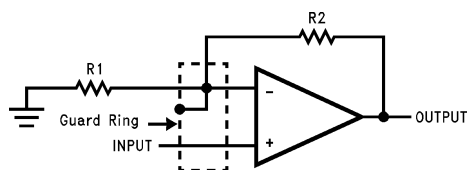

Figure 30. Non-Inverting Amplifier Guard Ring Connections

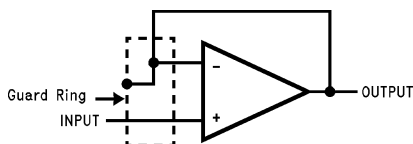

Figure 31. Follower Guard Ring Connections

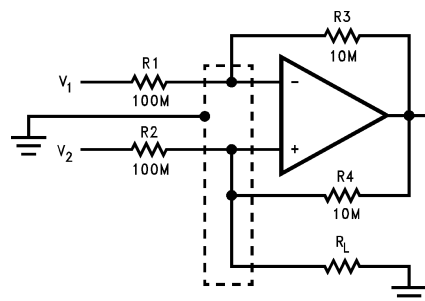
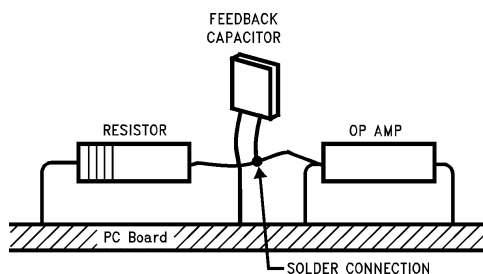

Figure 32. Howland Current Pump Guard Ring Connections

The designer should be aware that when it is inappropriate to lay out a PC board for the sake of just a few circuits, there is another technique which is even better than a guard ring on a PC board: Don't insert the amplifier's input pin into the board at all, but bend it up in the air and use only air as an insulator. Air is an excellent insulator. In this case you may have to forego some of the advantages of PC board construction, but the advantages are sometimes well worth the effort of using point-to-point up-in-the-air wiring. See [Figure 33](#).



(Input pins are lifted out of PC board and soldered directly to components. All other pins connected to PC board.)

Figure 33. Air Wiring

BIAS CURRENT TESTING

The test method of [Figure 34](#) is appropriate for bench-testing bias current with reasonable accuracy. To understand its operation, first close switch S2 momentarily. When S2 is opened, then

$$I^- = \frac{dV_{OUT}}{dt} \times C2. \quad (1)$$

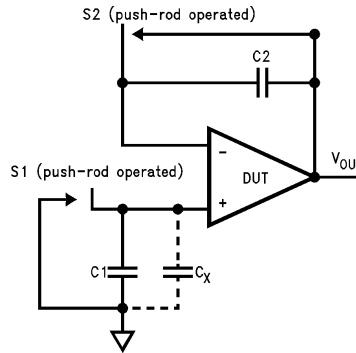

Figure 34. Simple Input Bias Current Test Circuit

A suitable capacitor for C2 would be a 5 pF or 10 pF silver mica, NPO ceramic, or air-dielectric. When determining the magnitude of I^- , the leakage of the capacitor and socket must be taken into account. Switch S2 should be left shorted most of the time, or else the dielectric absorption of the capacitor C2 could cause errors.

Similarly, if S1 is shorted momentarily (while leaving S2 shorted)

$$I^+ = \frac{dV_{OUT}}{dt} \times (C1 + C_x) \quad (2)$$

where C_x is the stray capacitance at the +input.

Typical Single-Supply Applications

($V^+ = 5.0 V_{DC}$)

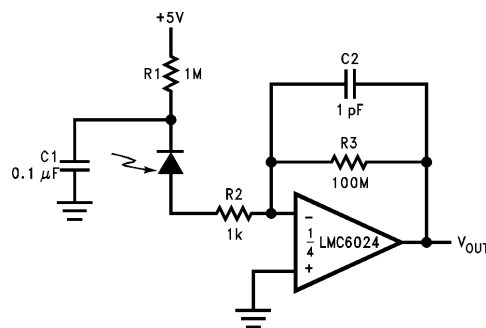

A 5V bias on the photodiode can cut its capacitance by a factor of 2 or 3, leading to improved response and lower noise. However, this bias on the photodiode will cause photodiode leakage (also known as its dark current).

Figure 35. Photodiode Current-to-Voltage Converter

($V^+ = 5.0 V_{DC}$)

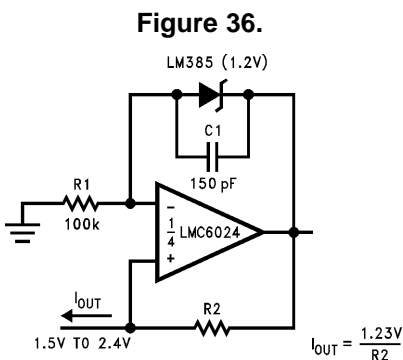

(Upper limit of output range dictated by input common-mode range; lower limit dictated by minimum current requirement of LM385.)

Figure 37. Micropower Current Source

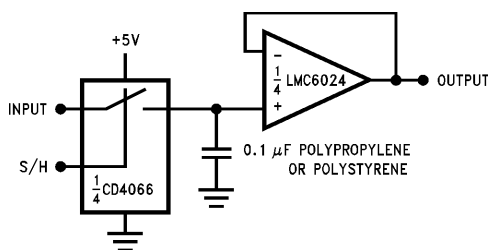
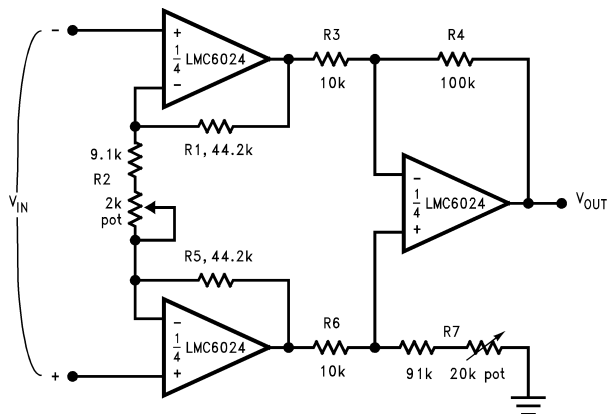

Figure 38. Low-Leakage Sample-and-Hold



If $R1 = R5$, $R3 = R6$, and $R4 = R7$;

Then

$$\frac{V_{OUT}}{V_{IN}} = \frac{R2 + 2R1}{R2} \times \frac{R4}{R3}$$

$\therefore A_v \approx 100$ for circuit shown.

For good CMRR over temperature, low drift resistors should be used. Matching of $R3$ to $R6$ and $R4$ to $R7$ affects CMRR. Gain may be adjusted through $R2$. CMRR may be adjusted through $R7$.

Figure 39. Instrumentation Amplifier

($V^+ = 5.0 V_{DC}$)

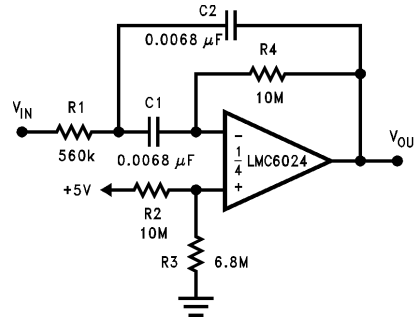

$f_0 = 10 \text{ Hz}$
 $Q = 2.1$
 Gain = -8.8

Figure 40. 10 Hz Bandpass Filter

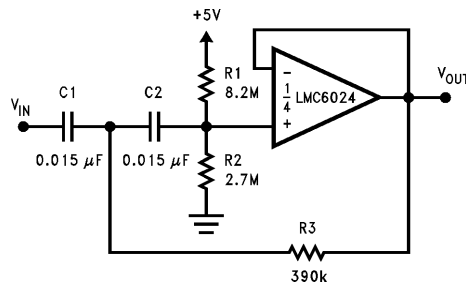

$f_c = 10 \text{ Hz}$
 $d = 0.895$
 Gain = 1

Figure 41. 10 Hz High-Pass Filter (2 dB Dip)

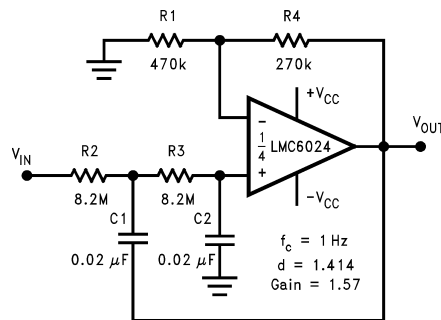

$f_c = 1 \text{ Hz}$
 $d = 1.414$
 Gain = 1.57

Figure 42. 1 Hz Low-Pass Filter (Maximally Flat, Dual Supply Only)

($V^+ = 5.0 V_{DC}$)

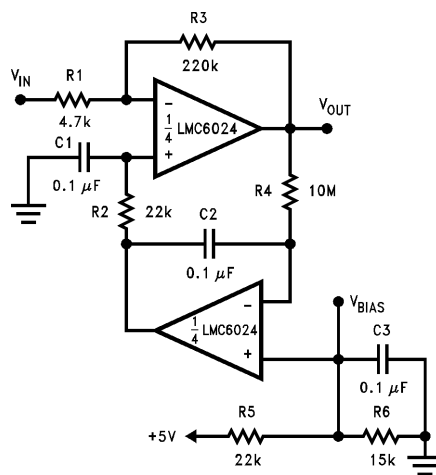

Gain = -46.8
 Output offset voltage reduced to the level of the input offset voltage of the bottom amplifier (typically 1 mV), referred to V_{BIAS} .

Figure 43. High Gain Amplifier with Offset Voltage Reduction

REVISION HISTORY

Changes from Revision C (March 2013) to Revision D	Page
• Changed layout of National Data Sheet to TI format	15

PACKAGING INFORMATION

Orderable Device	Status (1)	Package Type	Package Drawing	Pins	Package Qty	Eco Plan (2)	Lead/Ball Finish	MSL Peak Temp (3)	Op Temp (°C)	Top-Side Markings (4)	Samples
LMC6024IM	ACTIVE	SOIC	D	14	55	TBD	Call TI	Call TI	-40 to 85	LMC6024IM	Samples
LMC6024IM/NOPB	ACTIVE	SOIC	D	14	55	Green (RoHS & no Sb/Br)	CU SN	Level-1-260C-UNLIM	-40 to 85	LMC6024IM	Samples
LMC6024IMX	ACTIVE	SOIC	D	14	2500	TBD	Call TI	Call TI	-40 to 85	LMC6024IM	Samples
LMC6024IMX/NOPB	ACTIVE	SOIC	D	14	2500	Green (RoHS & no Sb/Br)	CU SN	Level-1-260C-UNLIM	-40 to 85	LMC6024IM	Samples

(1) The marketing status values are defined as follows:

ACTIVE: Product device recommended for new designs.

LIFEBUY: TI has announced that the device will be discontinued, and a lifetime-buy period is in effect.

NRND: Not recommended for new designs. Device is in production to support existing customers, but TI does not recommend using this part in a new design.

PREVIEW: Device has been announced but is not in production. Samples may or may not be available.

OBSOLETE: TI has discontinued the production of the device.

(2) Eco Plan - The planned eco-friendly classification: Pb-Free (RoHS), Pb-Free (RoHS Exempt), or Green (RoHS & no Sb/Br) - please check <http://www.ti.com/productcontent> for the latest availability information and additional product content details.

TBD: The Pb-Free/Green conversion plan has not been defined.

Pb-Free (RoHS): TI's terms "Lead-Free" or "Pb-Free" mean semiconductor products that are compatible with the current RoHS requirements for all 6 substances, including the requirement that lead not exceed 0.1% by weight in homogeneous materials. Where designed to be soldered at high temperatures, TI Pb-Free products are suitable for use in specified lead-free processes.

Pb-Free (RoHS Exempt): This component has a RoHS exemption for either 1) lead-based flip-chip solder bumps used between the die and package, or 2) lead-based die adhesive used between the die and leadframe. The component is otherwise considered Pb-Free (RoHS compatible) as defined above.

Green (RoHS & no Sb/Br): TI defines "Green" to mean Pb-Free (RoHS compatible), and free of Bromine (Br) and Antimony (Sb) based flame retardants (Br or Sb do not exceed 0.1% by weight in homogeneous material)

(3) MSL, Peak Temp. -- The Moisture Sensitivity Level rating according to the JEDEC industry standard classifications, and peak solder temperature.

(4) Multiple Top-Side Markings will be inside parentheses. Only one Top-Side Marking contained in parentheses and separated by a "~" will appear on a device. If a line is indented then it is a continuation of the previous line and the two combined represent the entire Top-Side Marking for that device.

Important Information and Disclaimer: The information provided on this page represents TI's knowledge and belief as of the date that it is provided. TI bases its knowledge and belief on information provided by third parties, and makes no representation or warranty as to the accuracy of such information. Efforts are underway to better integrate information from third parties. TI has taken and continues to take reasonable steps to provide representative and accurate information but may not have conducted destructive testing or chemical analysis on incoming materials and chemicals. TI and TI suppliers consider certain information to be proprietary, and thus CAS numbers and other limited information may not be available for release.

In no event shall TI's liability arising out of such information exceed the total purchase price of the TI part(s) at issue in this document sold by TI to Customer on an annual basis.

TAPE AND REEL INFORMATION



QUADRANT ASSIGNMENTS FOR PIN 1 ORIENTATION IN TAPE



*All dimensions are nominal

Device	Package Type	Package Drawing	Pins	SPQ	Reel Diameter (mm)	Reel Width W1 (mm)	A0 (mm)	B0 (mm)	K0 (mm)	P1 (mm)	W (mm)	Pin1 Quadrant
LMC6024IMX	SOIC	D	14	2500	330.0	16.4	6.5	9.35	2.3	8.0	16.0	Q1
LMC6024IMX/NOPB	SOIC	D	14	2500	330.0	16.4	6.5	9.35	2.3	8.0	16.0	Q1

TAPE AND REEL BOX DIMENSIONS

*All dimensions are nominal

Device	Package Type	Package Drawing	Pins	SPQ	Length (mm)	Width (mm)	Height (mm)
LMC6024IMX	SOIC	D	14	2500	367.0	367.0	35.0
LMC6024IMX/NOPB	SOIC	D	14	2500	367.0	367.0	35.0

D (R-PDSO-G14)

PLASTIC SMALL OUTLINE



- NOTES:
- A. All linear dimensions are in inches (millimeters).
 - B. This drawing is subject to change without notice.
 - Body length does not include mold flash, protrusions, or gate burrs. Mold flash, protrusions, or gate burrs shall not exceed 0.006 (0,15) each side.
 - Body width does not include interlead flash. Interlead flash shall not exceed 0.017 (0,43) each side.
 - E. Reference JEDEC MS-012 variation AB.

IMPORTANT NOTICE

Texas Instruments Incorporated and its subsidiaries (TI) reserve the right to make corrections, enhancements, improvements and other changes to its semiconductor products and services per JESD46, latest issue, and to discontinue any product or service per JESD48, latest issue. Buyers should obtain the latest relevant information before placing orders and should verify that such information is current and complete. All semiconductor products (also referred to herein as "components") are sold subject to TI's terms and conditions of sale supplied at the time of order acknowledgment.

TI warrants performance of its components to the specifications applicable at the time of sale, in accordance with the warranty in TI's terms and conditions of sale of semiconductor products. Testing and other quality control techniques are used to the extent TI deems necessary to support this warranty. Except where mandated by applicable law, testing of all parameters of each component is not necessarily performed.

TI assumes no liability for applications assistance or the design of Buyers' products. Buyers are responsible for their products and applications using TI components. To minimize the risks associated with Buyers' products and applications, Buyers should provide adequate design and operating safeguards.

TI does not warrant or represent that any license, either express or implied, is granted under any patent right, copyright, mask work right, or other intellectual property right relating to any combination, machine, or process in which TI components or services are used. Information published by TI regarding third-party products or services does not constitute a license to use such products or services or a warranty or endorsement thereof. Use of such information may require a license from a third party under the patents or other intellectual property of the third party, or a license from TI under the patents or other intellectual property of TI.

Reproduction of significant portions of TI information in TI data books or data sheets is permissible only if reproduction is without alteration and is accompanied by all associated warranties, conditions, limitations, and notices. TI is not responsible or liable for such altered documentation. Information of third parties may be subject to additional restrictions.

Resale of TI components or services with statements different from or beyond the parameters stated by TI for that component or service voids all express and any implied warranties for the associated TI component or service and is an unfair and deceptive business practice. TI is not responsible or liable for any such statements.

Buyer acknowledges and agrees that it is solely responsible for compliance with all legal, regulatory and safety-related requirements concerning its products, and any use of TI components in its applications, notwithstanding any applications-related information or support that may be provided by TI. Buyer represents and agrees that it has all the necessary expertise to create and implement safeguards which anticipate dangerous consequences of failures, monitor failures and their consequences, lessen the likelihood of failures that might cause harm and take appropriate remedial actions. Buyer will fully indemnify TI and its representatives against any damages arising out of the use of any TI components in safety-critical applications.

In some cases, TI components may be promoted specifically to facilitate safety-related applications. With such components, TI's goal is to help enable customers to design and create their own end-product solutions that meet applicable functional safety standards and requirements. Nonetheless, such components are subject to these terms.

No TI components are authorized for use in FDA Class III (or similar life-critical medical equipment) unless authorized officers of the parties have executed a special agreement specifically governing such use.

Only those TI components which TI has specifically designated as military grade or "enhanced plastic" are designed and intended for use in military/aerospace applications or environments. Buyer acknowledges and agrees that any military or aerospace use of TI components which have **not** been so designated is solely at the Buyer's risk, and that Buyer is solely responsible for compliance with all legal and regulatory requirements in connection with such use.

TI has specifically designated certain components as meeting ISO/TS16949 requirements, mainly for automotive use. In any case of use of non-designated products, TI will not be responsible for any failure to meet ISO/TS16949.

Products

Audio	www.ti.com/audio
Amplifiers	amplifier.ti.com
Data Converters	dataconverter.ti.com
DLP® Products	www.dlp.com
DSP	dsp.ti.com
Clocks and Timers	www.ti.com/clocks
Interface	interface.ti.com
Logic	logic.ti.com
Power Mgmt	power.ti.com
Microcontrollers	microcontroller.ti.com
RFID	www.ti-rfid.com
OMAP Applications Processors	www.ti.com/omap
Wireless Connectivity	www.ti.com/wirelessconnectivity

Applications

Automotive and Transportation	www.ti.com/automotive
Communications and Telecom	www.ti.com/communications
Computers and Peripherals	www.ti.com/computers
Consumer Electronics	www.ti.com/consumer-apps
Energy and Lighting	www.ti.com/energy
Industrial	www.ti.com/industrial
Medical	www.ti.com/medical
Security	www.ti.com/security
Space, Avionics and Defense	www.ti.com/space-avionics-defense
Video and Imaging	www.ti.com/video

TI E2E Community

e2e.ti.com