

LMV821 SINGLE, LMV822 DUAL, LMV824 QUAD LOW-VOLTAGE, RAIL-TO-RAIL OUTPUT OPERATIONAL AMPLIFIERS

SLOS434F – FEBRUARY 2004 – REVISED OCTOBER 2004

- 2.5-V, 2.7-V, and 5-V Performance
- –40°C to 125°C Operation
- No Crossover Distortion
- Low Supply Current at $V_{CC+} = 5\text{ V}$:
 LMV821 . . . 0.3 mA Typ
 LMV822 . . . 0.5 mA Typ
 LMV824 . . . 1 mA Typ
- Rail-to-Rail Output Swing
- Gain Bandwidth of 5.5 MHz Typ at 5 V
- Slew Rate of 1.9 V/ μs Typ at 5 V

description/ordering information

The LMV821, LMV822, and LMV824 single, dual, and quad devices are low-voltage (2.5 V to 5.5 V), low-power commodity operational amplifiers. Electrical characteristics are very similar to the LMV3xx operational amplifiers (low supply current, rail-to-rail outputs, input common-mode range, which includes ground). However, the LMV8XX devices offer a higher bandwidth (5.5 MHz typical) and faster slew rate (1.9 V/ μs typical).

The LMV8xx devices are cost-effective solutions for applications requiring low-voltage/low-power operation and space-saving considerations. The LMV821 is available in the ultra-small DCK package, which is approximately half the size of SOT23-5. The DCK package saves space on printed circuit boards and enables the design of small portable electronic devices (cordless and cellular phones, laptops, PDAs, PC/MIA). It also allows the designer to place the device closer to the signal source to reduce noise pickup and increase signal integrity.

The LMV8xx devices are characterized for operation from –40°C to 85°C. The LMV8xxI devices are characterized for operation from –40°C to 125°C.

LMV824 . . . D, DGV, OR PW PACKAGE
(TOP VIEW)

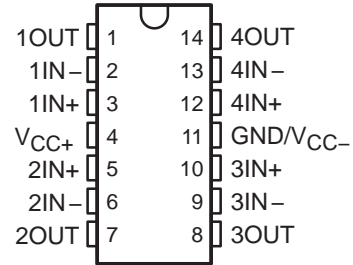

LMV822 . . . D OR DGK PACKAGE
(TOP VIEW)

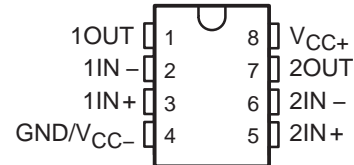

LMV821 . . . DBV OR DCK PACKAGE
(TOP VIEW)

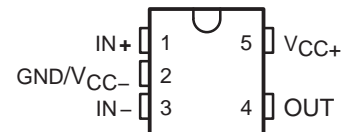

Please be aware that an important notice concerning availability, standard warranty, and use in critical applications of Texas Instruments semiconductor products and disclaimers thereto appears at the end of this data sheet.

PRODUCTION DATA information is current as of publication date. Products conform to specifications per the terms of Texas Instruments standard warranty. Production processing does not necessarily include testing of all parameters.



POST OFFICE BOX 655303 • DALLAS, TEXAS 75265

Copyright © 2004, Texas Instruments Incorporated

LMV821 SINGLE, LMV822 DUAL, LMV824 QUAD LOW-VOLTAGE, RAIL-TO-RAIL OUTPUT OPERATIONAL AMPLIFIERS

SLOS434F – FEBRUARY 2004 – REVISED OCTOBER 2004

ORDERING INFORMATION

T _A	PACKAGE†		ORDERABLE PART NUMBER	TOP-SIDE MARKING‡	
-40°C to 85°C	Single	SC-70 (DCKR)	Reel of 3000	LMV821DCKR	RY_
		SC-70 (DCKT)	Reel of 250	LMV821DCKT	
		SOT-23 (DBVR)	Reel of 3000	LMV821DBVR	RB8_
		SOT-23 (DBVT)	Reel of 250	LMV821DBVT	
	Dual	SOIC (D)	Tube of 75	LMV822D	MV822
			Reel of 2500	LMV822DR	
		MSOP/VSSOP (DGK)	Tube of 100	LMV822DGK	RAB
			Reel of 2500	LMV822DGKR	
	Quad	SOIC (D)	Tube of 50	LMV824D	LMV824
			Reel of 2500	LMV824DR	
		TSSOP (PW)	Tube of 90	LMV824PW	MV824
			Reel of 2000	LMV824PWR	
TVSOP (DGV)		Reel of 2000	LMV824DGVR	MV824	
-40°C to 125°C		Single	SC-70 (DCKR)	Reel of 3000	LMV821IDCKR
	SC-70 (DCKT)		Reel of 250	LMV821IDCKT	
	SOT-23 (DBVR)		Reel of 3000	LMV821IDBVR	RB1_
	SOT-23 (DBVT)		Reel of 250	LMV821IDBVT	
	Dual	SOIC (D)	Tube of 75	LMV822ID	MV822I
			Reel of 2500	LMV822IDR	
		MSOP/VSSOP (DGK)	Tube of 100	LMV822IDGK	R8_
			Reel of 2500	LMV822IDGKR	
	Quad	SOIC (D)	Tube of 50	LMV824ID	LMV824I
			Reel of 2500	LMV824IDR	
		TSSOP (PW)	Tube of 90	LMV824IPW	MV824I
			Reel of 2000	LMV824IPWR	
TVSOP (DGV)		Reel of 2000	LMV824IDGVR	MV824I	

† Package drawings, standard packing quantities, thermal data, symbolization, and PCB design guidelines are available at www.ti.com/sc/package.

‡ DBV/DCK: The actual top-side marking has one additional character that designates the assembly/test site.

symbol (each amplifier)

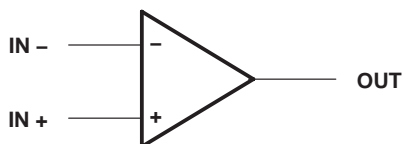

LMV821 SINGLE, LMV822 DUAL, LMV824 QUAD LOW-VOLTAGE, RAIL-TO-RAIL OUTPUT OPERATIONAL AMPLIFIERS

SLOS434F – FEBRUARY 2004 – REVISED OCTOBER 2004

LMV824 simplified schematic

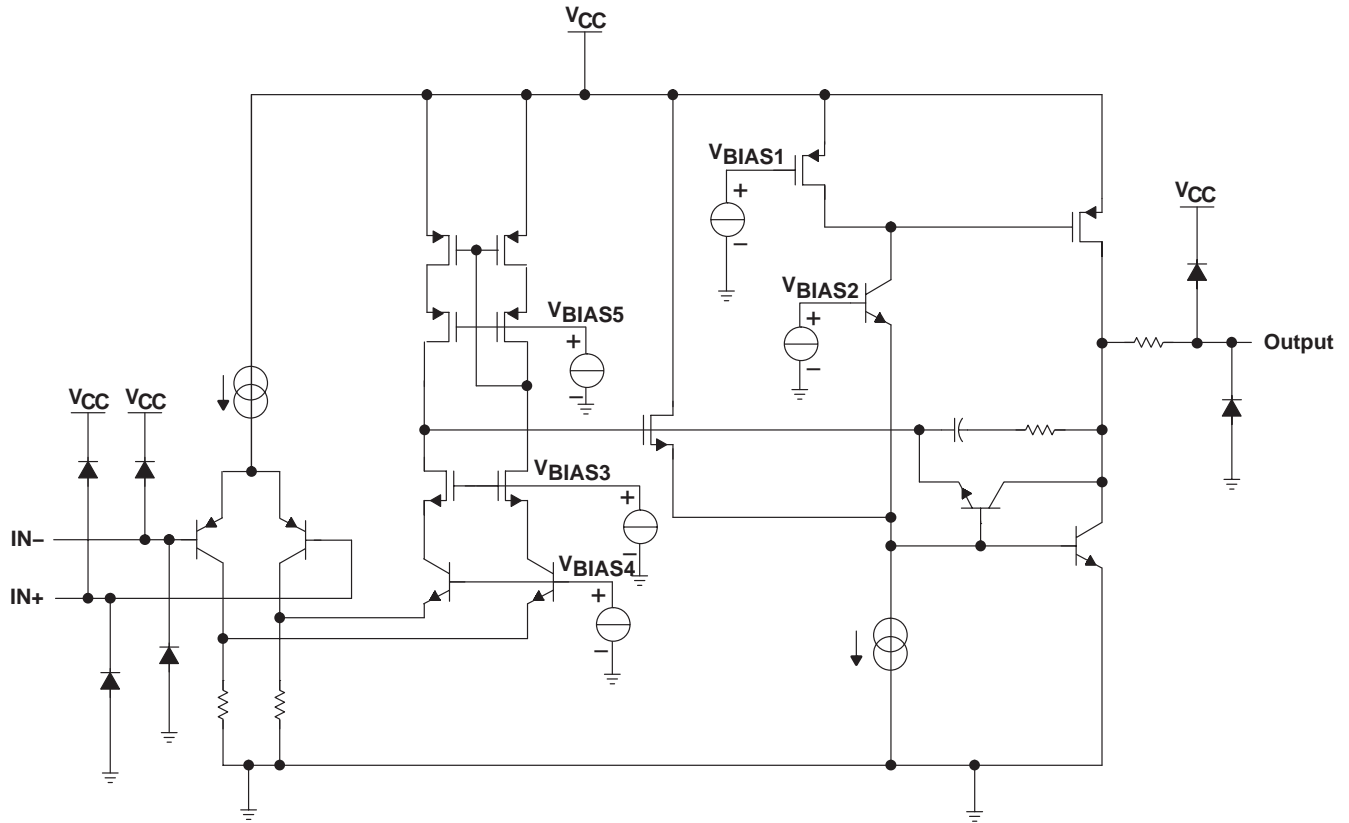

absolute maximum ratings over operating free-air temperature range (unless otherwise noted)†

Supply voltage, V_{CC} (see Note 1)	5.5 V
Differential input voltage V_{ID} (see Note 2)	$\pm V_{CC}$
Input voltage range, V_I (either input)	V_{CC-} to V_{CC+}
Duration of output short circuit (one amplifier) to ground at (or below), $T_A = 25^\circ\text{C}$, $V_{CC} \leq 5.5\text{ V}$ (see Note 3)	Unlimited
Package thermal impedance, θ_{JA} (see Notes 4 and 5):	
D (8-pin) package	97°C/W
D (14-pin) package	86°C/W
DBV package	206°C/W
DCK package	252°C/W
DGK package	172°C/W
DGV package	127°C/W
PW package	113°C/W
Operating virtual junction temperature, T_J	150°C
Storage temperature range, T_{Stg}	-65°C to 150°C

† Stresses beyond those listed under “absolute maximum ratings” may cause permanent damage to the device. These are stress ratings only, and functional operation of the device at these or any other conditions beyond those indicated under “recommended operating conditions” is not implied. Exposure to absolute-maximum-rated conditions for extended periods may affect device reliability.

- NOTES:
1. All voltage values (except differential voltages and V_{CC} specified for the measurement of I_{OS}) are with respect to the network GND.
 2. Differential voltages are at IN+ with respect to IN-.
 3. Short circuits from outputs to V_{CC} can cause excessive heating and eventual destruction.
 4. Maximum power dissipation is a function of $T_J(\text{max})$, θ_{JA} , and T_A . The maximum allowable power dissipation at any allowable ambient temperature is $P_D = (T_J(\text{max}) - T_A)/\theta_{JA}$. Selecting the maximum of 150°C can affect reliability.
 5. The package thermal impedance is calculated in accordance with JESD 51-7.



LMV821 SINGLE, LMV822 DUAL, LMV824 QUAD LOW-VOLTAGE, RAIL-TO-RAIL OUTPUT OPERATIONAL AMPLIFIERS

SLOS434F – FEBRUARY 2004 – REVISED OCTOBER 2004

recommended operating conditions

		MIN	MAX	UNIT	
V _{CC}	Supply voltage (single-supply operation)	2.5	5	V	
T _A	Operating free-air temperature	LMV8xxl	-40	125	°C
		LMV8xx	-40	85	°C

**2.5-V electrical characteristics, T_A = -40°C to 85°C,
V_{CC+} = 2.5 V, V_{CC-} = 0 V, V_{IC} = 1 V, V_O = 1.25 V, and R_L > 1 MΩ (unless otherwise noted)**

PARAMETER	TEST CONDITIONS	T _A	LMV8xx			UNIT
			MIN	TYP	MAX	
V _{IO} Input offset voltage		25°C	1		3.5	mV
		-40°C to 85°C			4	
V _O Output swing	V _{CC+} = 2.5 V, R _L = 600 Ω to 1.25 V	High level	25°C	2.30	2.37	V
			-40°C to 85°C	2.20		
		Low level	25°C	0.13		
		-40°C to 85°C			0.30	
	V _{CC+} = 2.5 V, R _L = 2 kΩ to 1.25 V	High level	25°C	2.40	2.46	
			-40°C to 85°C	2.30		
Low level		25°C	0.08		0.12	
		-40°C to 85°C			0.20	

**2.5-V electrical characteristics, T_A = -40°C to 125°C,
V_{CC+} = 2.5 V, V_{CC-} = 0 V, V_{IC} = 1 V, V_O = 1.25 V, and R_L > 1 MΩ (unless otherwise noted)**

PARAMETER	TEST CONDITIONS	T _A	LMV8xxl			UNIT
			MIN	TYP	MAX	
V _{IO} Input offset voltage		25°C	1		3.5	mV
		-40°C to 125°C			5.5	
V _O Output swing	V _{CC+} = 2.5 V, R _L = 600 Ω to 1.25 V	High level	25°C	2.28	2.37	V
			-40°C to 125°C	2.18		
		Low level	25°C	0.13		
		-40°C to 125°C			0.32	
	V _{CC+} = 2.5 V, R _L = 2 kΩ to 1.25 V	High level	25°C	2.38	2.46	
			-40°C to 125°C	2.28		
Low level		25°C	0.08		0.14	
		-40°C to 125°C			0.22	



LMV821 SINGLE, LMV822 DUAL, LMV824 QUAD LOW-VOLTAGE, RAIL-TO-RAIL OUTPUT OPERATIONAL AMPLIFIERS

SLOS434F – FEBRUARY 2004 – REVISED OCTOBER 2004

**2.7-V electrical characteristics, $T_A = -40^\circ\text{C}$ to 85°C ,
 $V_{CC+} = 2.7\text{ V}$, $V_{CC-} = 0\text{ V}$, $V_{IC} = 1\text{ V}$, $V_O = 1.35\text{ V}$, and $R_L > 1\text{ M}\Omega$ (unless otherwise noted)**

PARAMETER	TEST CONDITIONS	T_A	LMV8xx			UNIT
			MIN	TYP	MAX	
V_{IO} Input offset voltage		25°C	1	3.5	mV	
		-40°C to 85°C	4			
α_{VIO} Average temperature coefficient of input offset voltage		25°C	1		$\mu\text{V}/^\circ\text{C}$	
I_{IB} Input bias current		25°C	30	90	nA	
		-40°C to 85°C	140			
I_{IO} Input offset current		25°C	0.5	30	nA	
		-40°C to 85°C	50			
CMRR Common-mode rejection ratio	$V_{IC} = 0$ to 1.7 V	25°C	70	85	dB	
		-40°C to 85°C	68			
+kSVR Positive supply-voltage rejection ratio	$V_{CC+} = 1.7\text{ V}$ to 4 V, $V_{CC-} = -1\text{ V}$, $V_O = 0$, $V_{IC} = 0$	25°C	75	85	dB	
		-40°C to 85°C	70			
-kSVR Negative supply-voltage rejection ratio	$V_{CC+} = 1.7\text{ V}$, $V_{CC-} = -1\text{ V}$ to -3.3 V, $V_O = 0$, $V_{IC} = 0$	25°C	73	85	dB	
		-40°C to 85°C	70			
V_{ICR} Common-mode input voltage range	CMRR ≥ 50 dB	25°C	-0.2 to 1.9	-0.3 to 2	V	
A_V Large-signal voltage amplification	$R_L = 600\ \Omega$ to 1.35 V, $V_O = 1.35\text{ V}$ to 2.2 V	Sourcing	25°C	90	100	dB
			-40°C to 85°C	85		
	$R_L = 600\ \Omega$ to 1.35 V, $V_O = 1.35\text{ V}$ to 0.5 V	Sinking	25°C	85	90	
			-40°C to 85°C	80		
$R_L = 2\text{ k}\Omega$ to 1.35 V, $V_O = 1.35\text{ V}$ to 2.2 V	Sourcing	25°C	95	100		
		-40°C to 85°C	90			
$R_L = 2\text{ k}\Omega$ to 1.35 V, $V_O = 1.35\text{ V}$ to 0.5 V	Sinking	25°C	90	95		
		-40°C to 85°C	85			
V_O Output swing	$V_{CC+} = 2.7\text{ V}$, $R_L = 600\ \Omega$ to 1.35 V	High level	25°C	2.50	2.58	V
			-40°C to 85°C	2.40		
	Low level	25°C	0.13	0.20		
		-40°C to 85°C	0.30			
	$V_{CC+} = 2.7\text{ V}$, $R_L = 2\text{ k}\Omega$ to 1.35 V	High level	25°C	2.60	2.66	
			-40°C to 85°C	2.50		
Low level	25°C	0.08	0.120			
	-40°C to 85°C	0.200				
I_O Output current	$V_O = 0\text{ V}$	Sourcing	25°C	12	16	mA
	$V_O = 2.7\text{ V}$	Sinking	25°C	12	26	



LMV821 SINGLE, LMV822 DUAL, LMV824 QUAD LOW-VOLTAGE, RAIL-TO-RAIL OUTPUT OPERATIONAL AMPLIFIERS

SLOS434F – FEBRUARY 2004 – REVISED OCTOBER 2004

2.7-V electrical characteristics, $T_A = -40^\circ\text{C}$ to 85°C ,
 $V_{CC+} = 2.7\text{ V}$, $V_{CC-} = 0\text{ V}$, $V_{IC} = 1\text{ V}$, $V_O = 1.35\text{ V}$, and $R_L > 1\text{ M}\Omega$ (unless otherwise noted)
 (continued)

PARAMETER	TEST CONDITIONS	T_A	LMV8xx			UNIT
			MIN	TYP	MAX	
I_{CC} Supply current	LMV821	25°C	0.22	0.3	mA	
		-40°C to 85°C	0.5			
	LMV822 (both amplifiers)	25°C	0.45	0.6		
		-40°C to 85°C	0.8			
	LMV824 (all four amplifiers)	25°C	0.72	1.0		
		-40°C to 85°C	1.2			
SR Slew rate†		25°C	1.7		V/ μs	
GBW Gain-bandwidth product	See Note 6	25°C	5		MHz	
ϕ_m Phase margin	See Note 6	25°C	60		deg	
Gain margin	See Note 6	25°C	8.6		dB	
Amplifier-to-amplifier isolation	$V_{CC+} = 5\text{ V}$, $R_L = 100\text{ k}\Omega$ to $2.5\text{ V}\ddagger$	25°C	135		dB	
V_n Equivalent input noise voltage	$f = 1\text{ kHz}$, $V_{IC} = 1\text{ V}$	25°C	45		nV/ $\sqrt{\text{Hz}}$	
I_n Equivalent input noise current	$f = 1\text{ kHz}$	25°C	0.18		pA/ $\sqrt{\text{Hz}}$	
THD Total harmonic distortion	$f = 1\text{ kHz}$, $A_V = -2$, $R_L = 10\text{ k}\Omega$, $V_O = 4.1\text{ V}_{p-p}$	25°C	0.01		%	

† Connected as voltage follower with 1-V step input. Value specified is the slower of the positive and negative slew rates.

‡ Each amplifier excited in turn with 1 kHz to produce $V_O = 3\text{ V}_{p-p}$

NOTE 6: 40-dB closed-loop dc gain, $C_L = 22\text{ pF}$

LMV821 SINGLE, LMV822 DUAL, LMV824 QUAD LOW-VOLTAGE, RAIL-TO-RAIL OUTPUT OPERATIONAL AMPLIFIERS

SLOS434F – FEBRUARY 2004 – REVISED OCTOBER 2004

2.7-V electrical characteristics, $T_A = -40^\circ\text{C}$ to 125°C , $V_{CC+} = 2.7\text{ V}$, $V_{CC-} = 0\text{ V}$, $V_{IC} = 1\text{ V}$, $V_O = 1.35\text{ V}$, and $R_L > 1\text{ M}\Omega$ (unless otherwise noted)

PARAMETER	TEST CONDITIONS	T_A	LMV8xxI			UNIT
			MIN	TYP	MAX	
V_{IO} Input offset voltage		25°C	1	3.5	mV	
		-40°C to 125°C		5.5		
α_{VIO} Average temperature coefficient of input offset voltage		25°C	1		$\mu\text{V}/^\circ\text{C}$	
I_{IB} Input bias current		25°C	30	90	nA	
		-40°C to 125°C		140		
I_{IO} Input offset current		25°C	0.5	30	nA	
		-40°C to 125°C		50		
CMRR Common-mode rejection ratio	$V_{IC} = 0$ to 1.7 V	25°C	70	85	dB	
		-40°C to 125°C	68			
+kSVR Positive supply-voltage rejection ratio	$V_{CC+} = 1.7\text{ V}$ to 4 V, $V_{CC-} = -1\text{ V}$, $V_O = 0$, $V_{IC} = 0$	25°C	75	85	dB	
		-40°C to 125°C	70			
-kSVR Negative supply-voltage rejection ratio	$V_{CC+} = 1.7\text{ V}$, $V_{CC-} = -1\text{ V}$ to -3.3 V, $V_O = 0$, $V_{IC} = 0$	25°C	73	85	dB	
		-40°C to 125°C	70			
V_{ICR} Common-mode input voltage range	CMRR ≥ 50 dB	25°C	-0.2 to 1.9	-0.3 to 2	V	
A_V Large-signal voltage amplification	$R_L = 600\ \Omega$ to 1.35 V, $V_O = 1.35\text{ V}$ to 2.2 V	Sourcing	25°C	90	100	dB
			-40°C to 125°C	85		
	$R_L = 600\ \Omega$ to 1.35 V, $V_O = 1.35\text{ V}$ to 0.5 V	Sinking	25°C	85	90	
			-40°C to 125°C	80		
	$R_L = 2\text{ k}\Omega$ to 1.35 V, $V_O = 1.35\text{ V}$ to 2.2 V	Sourcing	25°C	95	100	
			-40°C to 125°C	90		
	$R_L = 2\text{ k}\Omega$ to 1.35 V, $V_O = 1.35\text{ V}$ to 0.5 V	Sinking	25°C	90	95	
			-40°C to 125°C	85		
V_O Output swing	$V_{CC+} = 2.7\text{ V}$, $R_L = 600\ \Omega$ to 1.35 V	High level	25°C	2.50	2.58	V
			-40°C to 125°C	2.40		
		Low level	25°C	0.13	0.20	
			-40°C to 125°C		0.30	
	$V_{CC+} = 2.7\text{ V}$, $R_L = 2\text{ k}\Omega$ to 1.35 V	High level	25°C	2.60	2.66	
			-40°C to 125°C	2.50		
		Low level	25°C	0.08	0.120	
			-40°C to 125°C		0.200	
I_O Output current	$V_O = 0\text{ V}$	Sourcing	25°C	12	16	mA
	$V_O = 2.7\text{ V}$			Sinking	12	



LMV821 SINGLE, LMV822 DUAL, LMV824 QUAD LOW-VOLTAGE, RAIL-TO-RAIL OUTPUT OPERATIONAL AMPLIFIERS

SLOS434F – FEBRUARY 2004 – REVISED OCTOBER 2004

2.7-V electrical characteristics, $T_A = -40^\circ\text{C}$ to 125°C ,
 $V_{CC+} = 2.7\text{ V}$, $V_{CC-} = 0\text{ V}$, $V_{IC} = 1\text{ V}$, $V_O = 1.35\text{ V}$, and $R_L > 1\text{ M}\Omega$ (unless otherwise noted)
 (continued)

PARAMETER	TEST CONDITIONS	T_A	LMV8xxI			UNIT
			MIN	TYP	MAX	
I_{CC} Supply current	LMV821	25°C	0.22	0.3	mA	
		-40°C to 125°C		0.5		
	LMV822 (both amplifiers)	25°C	0.45	0.6		
		-40°C to 125°C		0.8		
	LMV824 (all four amplifiers)	25°C	0.72	1.0		
		-40°C to 125°C		1.2		
SR Slew rate†		25°C	1.7		V/ μs	
GBW Gain-bandwidth product	See Note 6	25°C	5		MHz	
ϕ_m Phase margin	See Note 6	25°C	60		deg	
Gain margin	See Note 6	25°C	8.6		dB	
Amplifier-to-amplifier isolation	$V_{CC+} = 5\text{ V}$, $R_L = 100\text{ k}\Omega$ to $2.5\text{ V}\ddagger$	25°C	135		dB	
V_n Equivalent input noise voltage	$f = 1\text{ kHz}$, $V_{IC} = 1\text{ V}$	25°C	45		nV/ $\sqrt{\text{Hz}}$	
I_n Equivalent input noise current	$f = 1\text{ kHz}$	25°C	0.18		pA/ $\sqrt{\text{Hz}}$	
THD Total harmonic distortion	$f = 1\text{ kHz}$, $A_V = -2$, $R_L = 10\text{ k}\Omega$, $V_O = 4.1\text{ V}_{p-p}$	25°C	0.01		%	

† Connected as voltage follower with 1-V step input. Value specified is the slower of the positive and negative slew rates.

‡ Each amplifier excited in turn with 1 kHz to produce $V_O = 3\text{ V}_{p-p}$

NOTE 6: 40-dB closed-loop dc gain, $C_L = 22\text{ pF}$

LMV821 SINGLE, LMV822 DUAL, LMV824 QUAD LOW-VOLTAGE, RAIL-TO-RAIL OUTPUT OPERATIONAL AMPLIFIERS

SLOS434F – FEBRUARY 2004 – REVISED OCTOBER 2004

**5-V electrical characteristics, $T_A = -40^\circ\text{C}$ to 85°C ,
 $V_{CC+} = 5\text{ V}$, $V_{CC-} = 0\text{ V}$, $V_{IC} = 2\text{ V}$, $V_O = 2.5\text{ V}$, and $R_L > 1\text{ M}\Omega$ (unless otherwise noted)**

PARAMETER	TEST CONDITIONS	T_A	LMV8xx			UNIT	
			MIN	TYP	MAX		
V_{IO} Input offset voltage		25°C		1	3.5	mV	
		-40°C to 85°C			4		
α_{VIO} Average temperature coefficient of input offset voltage		25°C		1		$\mu\text{V}/^\circ\text{C}$	
I_{IB} Input bias current		25°C		40	100	nA	
		-40°C to 85°C			150		
I_{IO} Input offset current		25°C		0.5	30	nA	
		-40°C to 85°C			50		
CMRR Common-mode rejection ratio	$V_{IC} = 0$ to 4 V	25°C		72	90	dB	
		-40°C to 85°C			70		
+kSVR Positive supply-voltage rejection ratio	$V_{CC+} = 1.7\text{ V}$ to 4 V, $V_{CC-} = -1\text{ V}$, $V_O = 0$, $V_{IC} = 0$	25°C		75	85	dB	
		-40°C to 85°C			70		
-kSVR Negative supply-voltage rejection ratio	$V_{CC+} = 1.7\text{ V}$, $V_{CC-} = -1\text{ V}$ to -3.3 V, $V_O = 0$, $V_{IC} = 0$	25°C		73	85	dB	
		-40°C to 85°C			70		
V_{ICR} Common-mode input voltage range	CMRR ≥ 50 dB	25°C		-0.2 to 4.2	-0.3 to 4.3	V	
A_V Large-signal voltage amplification	$R_L = 600\ \Omega$ to 2.5 V, $V_O = 2.5\text{ V}$ to 4.5 V	Sourcing	25°C		95	105	dB
			-40°C to 85°C			90	
	$R_L = 600\ \Omega$ to 2.5 V, $V_O = 2.5\text{ V}$ to 0.5 V	Sinking	25°C		95	105	
			-40°C to 85°C			90	
$R_L = 2\text{ k}\Omega$ to 2.5 V, $V_O = 2.5\text{ V}$ to 4.5 V	Sourcing	25°C		95	105		
		-40°C to 85°C			90		
$R_L = 2\text{ k}\Omega$ to 2.5 V, $V_O = 2.5\text{ V}$ to 0.5 V	Sinking	25°C		95	105		
		-40°C to 85°C			90		
V_O Output swing	$V_{CC+} = 5\text{ V}$, $R_L = 600\ \Omega$ to 2.5 V	High level	25°C		4.75	4.84	V
			-40°C to 85°C			4.70	
	Low level	25°C		0.17	0.250		
		-40°C to 85°C			0.30		
	$V_{CC+} = 5\text{ V}$, $R_L = 2\text{ k}\Omega$ to 2.5 V	High level	25°C		4.85	4.90	
			-40°C to 85°C			4.80	
Low level	25°C		0.10	0.15			
	-40°C to 85°C			0.20			
I_O Output current	$V_O = 0\text{ V}$	Sourcing	25°C		20	45	mA
			-40°C to 85°C			15	
	$V_O = 5\text{ V}$	Sinking	25°C		20	40	
			-40°C to 85°C			15	



LMV821 SINGLE, LMV822 DUAL, LMV824 QUAD LOW-VOLTAGE, RAIL-TO-RAIL OUTPUT OPERATIONAL AMPLIFIERS

SLOS434F – FEBRUARY 2004 – REVISED OCTOBER 2004

5-V electrical characteristics, $T_A = -40^\circ\text{C}$ to 85°C ,
 $V_{CC+} = 5\text{ V}$, $V_{CC-} = 0\text{ V}$, $V_{IC} = 2\text{ V}$, $V_O = 2.5\text{ V}$, and $R_L > 1\text{ M}\Omega$ (unless otherwise noted) (continued)

PARAMETER	TEST CONDITIONS	T_A	LMV8xx			UNIT
			MIN	TYP	MAX	
I_{CC} Supply current	LMV821	25°C	0.30	0.4	mA	
		-40°C to 85°C		0.6		
	LMV822 (both amplifiers)	25°C	0.5	0.7		
		-40°C to 85°C		0.9		
	LMV824 (all four amplifiers)	25°C	1.0	1.3		
		-40°C to 85°C		1.5		
SR Slew rate†		25°C	1.4	1.9	V/ μs	
GBW Gain-bandwidth product	See Note 6	25°C	5.5		MHz	
ϕ_m Phase margin	See Note 6	25°C	64.2		deg	
Gain margin	See Note 6	25°C	8.7		dB	
Amplifier-to-amplifier isolation	$V_{CC+} = 5\text{ V}$, $R_L = 100\text{ k}\Omega$ to $2.5\text{ V}\ddagger$	25°C	135		dB	
V_n Equivalent input noise voltage	$f = 1\text{ kHz}$, $V_{IC} = 1\text{ V}$	25°C	42		nV/ $\sqrt{\text{Hz}}$	
I_n Equivalent input noise current	$f = 1\text{ kHz}$	25°C	0.20		pA/ $\sqrt{\text{Hz}}$	
THD Total harmonic distortion	$f = 1\text{ kHz}$, $A_V = -2$, $R_L = 10\text{ k}\Omega$, $V_O = 4.1\text{ V}_{p-p}$	25°C	0.01		%	

† Connected as voltage follower with 3-V step input. Value specified is the slower of the positive and negative slew rates.

‡ Each amplifier excited in turn with 1 kHz to produce $V_O = 3\text{ V}_{p-p}$

NOTE 6: 40-dB closed-loop dc gain, $C_L = 22\text{ pF}$



LMV821 SINGLE, LMV822 DUAL, LMV824 QUAD LOW-VOLTAGE, RAIL-TO-RAIL OUTPUT OPERATIONAL AMPLIFIERS

SLOS434F – FEBRUARY 2004 – REVISED OCTOBER 2004

**5-V electrical characteristics, $T_A = -40^\circ\text{C}$ to 125°C ,
 $V_{CC+} = 5\text{ V}$, $V_{CC-} = 0\text{ V}$, $V_{IC} = 2\text{ V}$, $V_O = 2.5\text{ V}$, and $R_L > 1\text{ M}\Omega$ (unless otherwise noted)**

PARAMETER	TEST CONDITIONS	T_A	LMV8xxI			UNIT
			MIN	TYP	MAX	
V_{IO} Input offset voltage		25°C	1	3.5	mV	
		-40°C to 125°C	5.5			
α_{VIO} Average temperature coefficient of input offset voltage		25°C	1		$\mu\text{V}/^\circ\text{C}$	
I_{IB} Input bias current		25°C	40	100	nA	
		-40°C to 125°C	150			
I_{IO} Input offset current		25°C	0.5	30	nA	
		-40°C to 125°C	50			
CMRR Common-mode rejection ratio	$V_{IC} = 0$ to 4 V	25°C	72	90	dB	
		-40°C to 125°C	70			
+kSVR Positive supply-voltage rejection ratio	$V_{CC+} = 1.7\text{ V}$ to 4 V, $V_{CC-} = -1\text{ V}$, $V_O = 0$, $V_{IC} = 0$	25°C	75	85	dB	
-kSVR Negative supply-voltage rejection ratio	$V_{CC+} = 1.7\text{ V}$, $V_{CC-} = -1\text{ V}$ to -3.3 V, $V_O = 0$, $V_{IC} = 0$	25°C	73	85		
		-40°C to 125°C	70			
V_{ICR} Common-mode input voltage range	CMRR ≥ 50 dB	25°C	-0.2 to 4.2	-0.3 to 4.3	V	
A_V Large-signal voltage amplification	$R_L = 600\ \Omega$ to 2.5 V, $V_O = 2.5\text{ V}$ to 4.5 V	Sourcing	25°C	95	105	dB
			-40°C to 125°C	90		
	Sinking	25°C	95	105		
		-40°C to 125°C	90			
$R_L = 2\text{ k}\Omega$ to 2.5 V, $V_O = 2.5\text{ V}$ to 4.5 V	Sourcing	25°C	95	105		
		-40°C to 125°C	90			
$R_L = 2\text{ k}\Omega$ to 2.5 V, $V_O = 2.5\text{ V}$ to 0.5 V	Sinking	25°C	95	105		
		-40°C to 125°C	90			
V_O Output swing	$V_{CC+} = 5\text{ V}$, $R_L = 600\ \Omega$ to 2.5 V	High level	25°C	4.75	4.84	V
			-40°C to 125°C	4.60		
	Low level	25°C	0.17	0.250		
		-40°C to 125°C	0.30			
	$V_{CC+} = 5\text{ V}$, $R_L = 2\text{ k}\Omega$ to 2.5 V	High level	25°C	4.85	4.90	
			-40°C to 125°C	4.80		
Low level	25°C	0.10	0.15			
	-40°C to 125°C	0.20				
I_O Output current	$V_O = 0\text{ V}$	Sourcing	25°C	20	45	mA
			-40°C to 125°C	15		
	$V_O = 5\text{ V}$	Sinking	25°C	20	40	
			-40°C to 125°C	15		



LMV821 SINGLE, LMV822 DUAL, LMV824 QUAD LOW-VOLTAGE, RAIL-TO-RAIL OUTPUT OPERATIONAL AMPLIFIERS

SLOS434F – FEBRUARY 2004 – REVISED OCTOBER 2004

5-V electrical characteristics, $T_A = -40^\circ\text{C}$ to 125°C ,
 $V_{CC+} = 5\text{ V}$, $V_{CC-} = 0\text{ V}$, $V_{IC} = 2\text{ V}$, $V_O = 2.5\text{ V}$, and $R_L > 1\text{ M}\Omega$ (unless otherwise noted) (continued)

PARAMETER	TEST CONDITIONS	T_A	LMV8xxI			UNIT
			MIN	TYP	MAX	
I_{CC} Supply current	LMV821	25°C	0.3	0.4	mA	
		-40°C to 125°C		0.6		
	LMV822 (both amplifiers)	25°C	0.5	0.7		
		-40°C to 125°C		0.9		
	LMV824 (all four amplifiers)	25°C	1	1.3		
		-40°C to 125°C		1.5		
SR Slew rate	$V_{CC+} = 5\text{ V}^\dagger$	25°C	1.4	1.9	V/ μs	
GBW Gain-bandwidth product	See Note 6	25°C	5.5		MHz	
ϕ_m Phase margin	See Note 6	25°C	64.2		deg	
Gain margin	See Note 6	25°C	8.7		dB	
Amp-to-amp isolation	$V_{CC+} = 5\text{ V}$, $R_L = 100\text{ k}\Omega$ to 2.5 V^\ddagger	25°C	135		dB	
V_n Equivalent input noise voltage	$f = 1\text{ kHz}$, $V_{IC} = 1\text{ V}$	25°C	42		nV/ $\sqrt{\text{Hz}}$	
I_n Equivalent input noise current	$f = 1\text{ kHz}$	25°C	0.20		pA/ $\sqrt{\text{Hz}}$	
THD Total harmonic distortion	$f = 1\text{ kHz}$, $A_V = -2$, $R_L = 10\text{ k}\Omega$, $V_O = 4.1\text{ V}_{p-p}$	25°C	0.01		%	

† Connected as voltage follower with 3-V step input. Value specified is the slower of the positive and negative slew rates.

‡ Each amplifier excited in turn with 1 kHz to produce $V_O = 3\text{ V}_{p-p}$

NOTE 6: 40-dB closed-loop dc gain, $C_L = 22\text{ pF}$



LMV821 SINGLE, LMV822 DUAL, LMV824 QUAD LOW-VOLTAGE, RAIL-TO-RAIL OUTPUT OPERATIONAL AMPLIFIERS

SLOS434F – FEBRUARY 2004 – REVISED OCTOBER 2004

TYPICAL CHARACTERISTICS ($T_A = 25^\circ\text{C}$, $V_{CC+} = 5\text{-V}$ Single Supply, Unless Otherwise Noted)

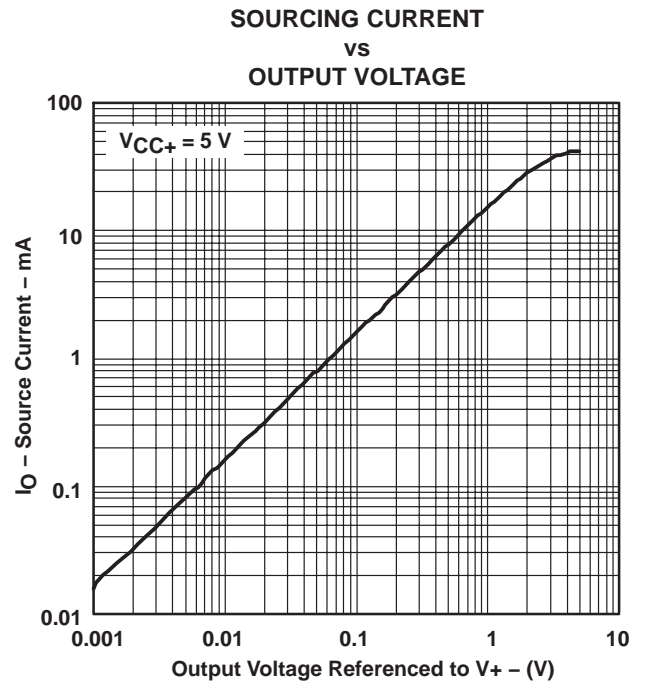
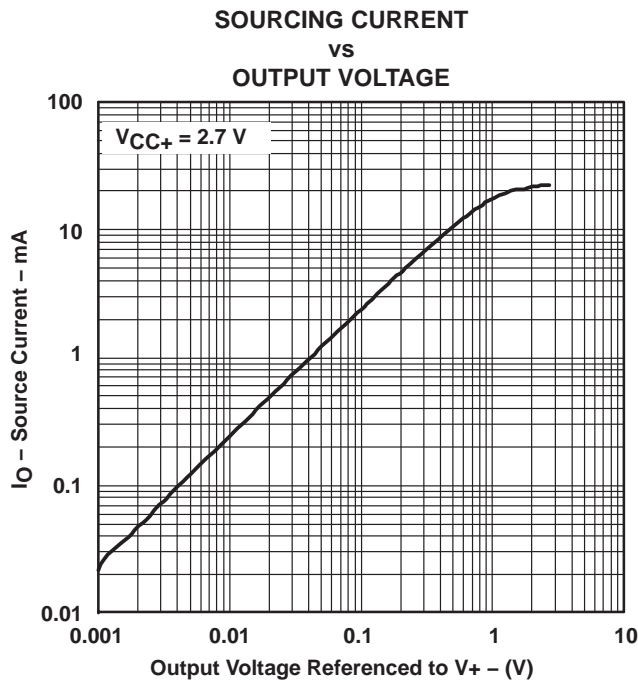
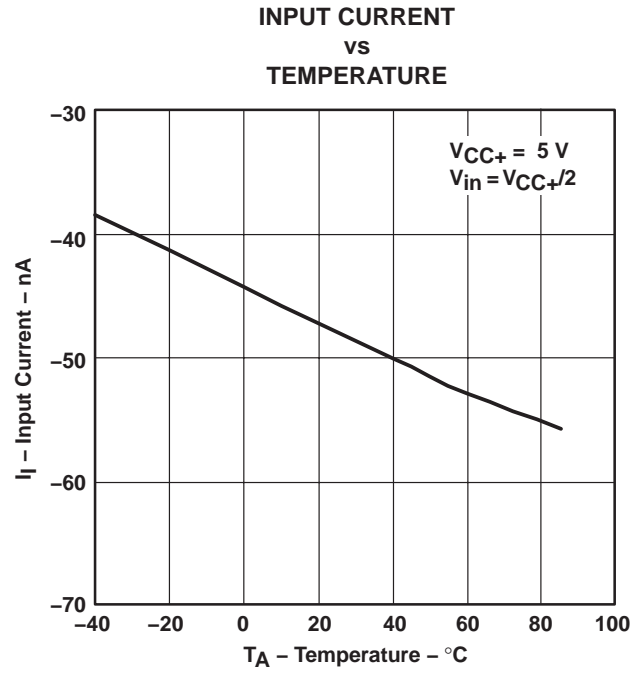
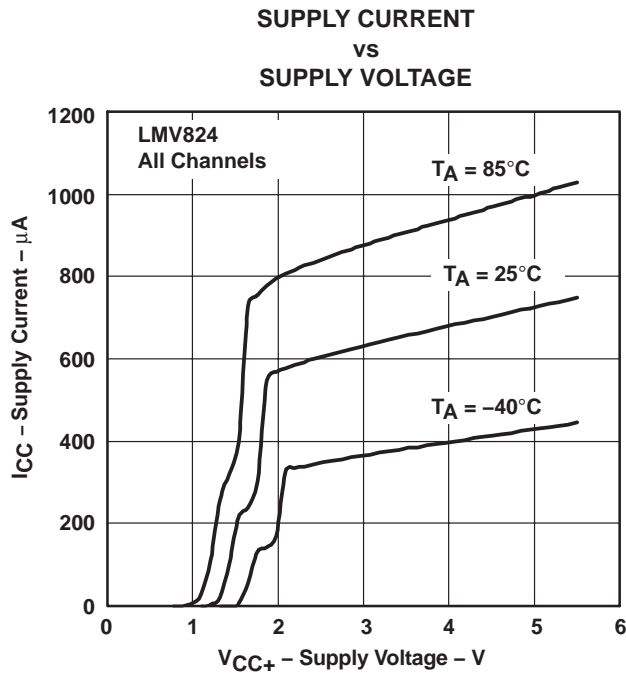

LMV821 SINGLE, LMV822 DUAL, LMV824 QUAD LOW-VOLTAGE, RAIL-TO-RAIL OUTPUT OPERATIONAL AMPLIFIERS

SLOS434F – FEBRUARY 2004 – REVISED OCTOBER 2004

TYPICAL CHARACTERISTICS ($T_A = 25^\circ\text{C}$, $V_{CC+} = 5\text{-V}$ Single Supply, Unless Otherwise Noted)

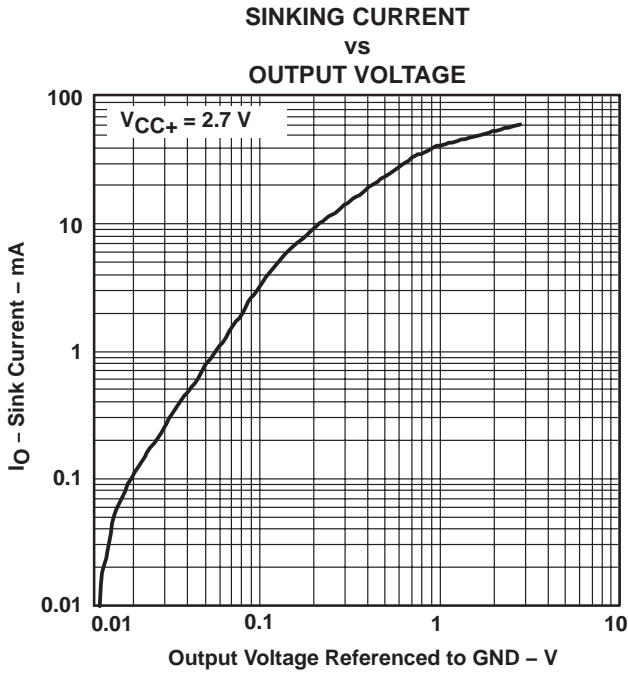

Figure 5

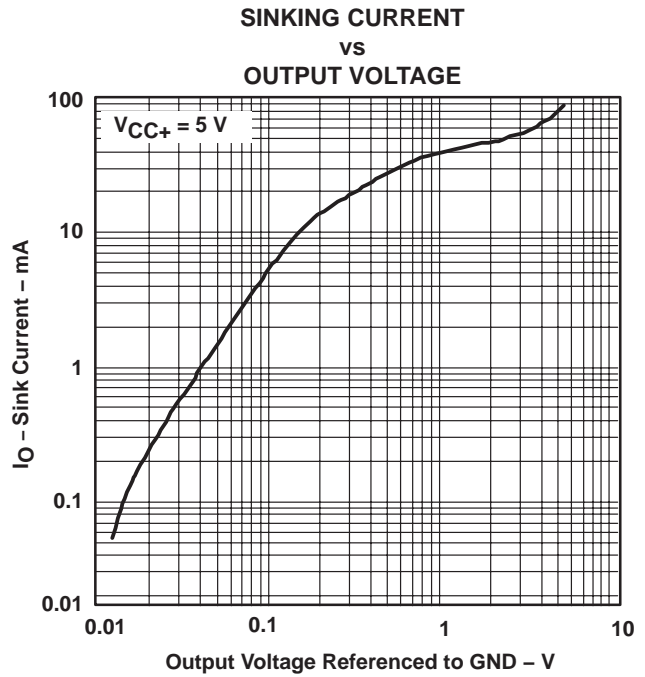

Figure 6

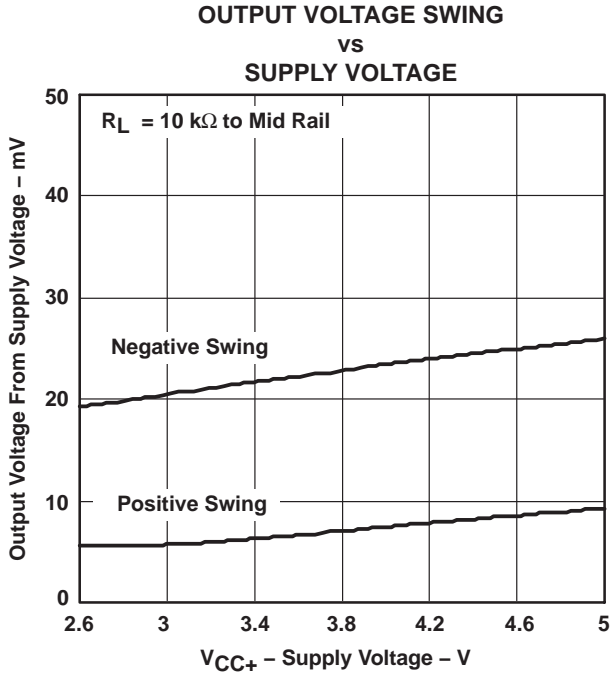

Figure 7

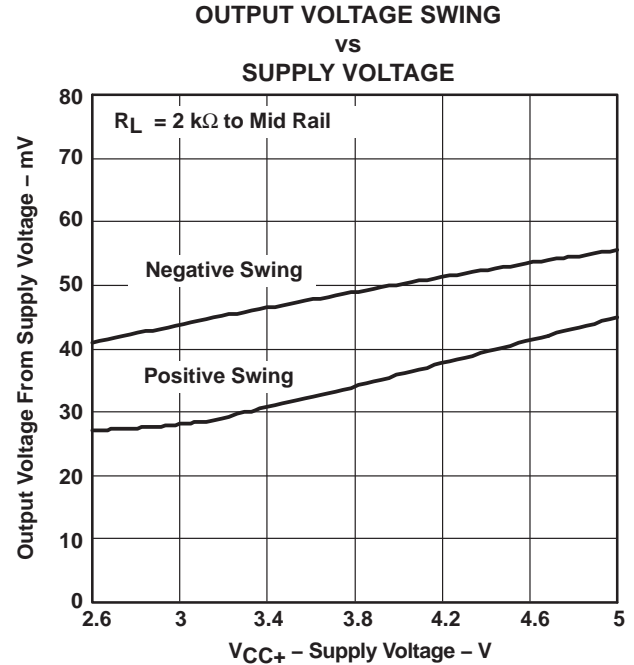

Figure 8



LMV821 SINGLE, LMV822 DUAL, LMV824 QUAD LOW-VOLTAGE, RAIL-TO-RAIL OUTPUT OPERATIONAL AMPLIFIERS

SLOS434F – FEBRUARY 2004 – REVISED OCTOBER 2004

TYPICAL CHARACTERISTICS ($T_A = 25^\circ\text{C}$, $V_{CC+} = 5\text{-V}$ Single Supply, Unless Otherwise Noted)

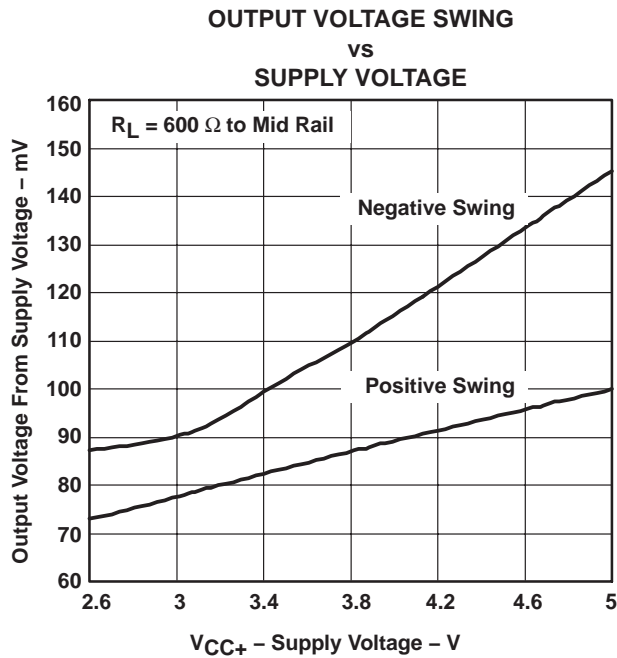

Figure 9

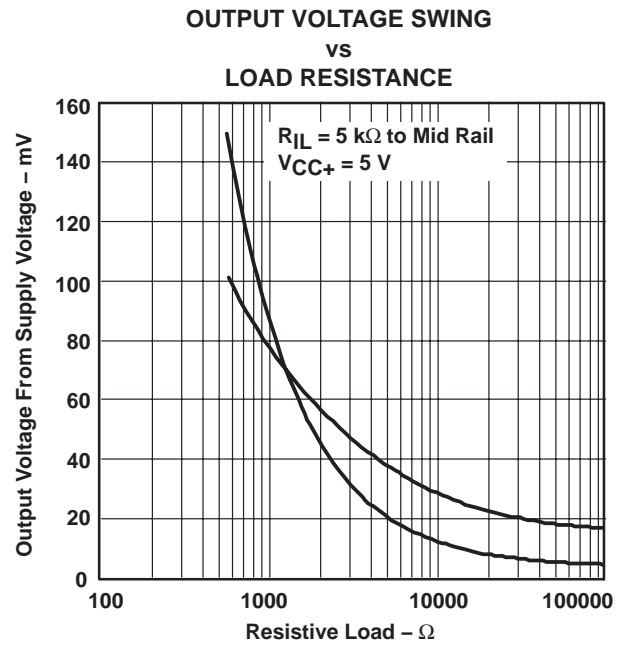

Figure 10

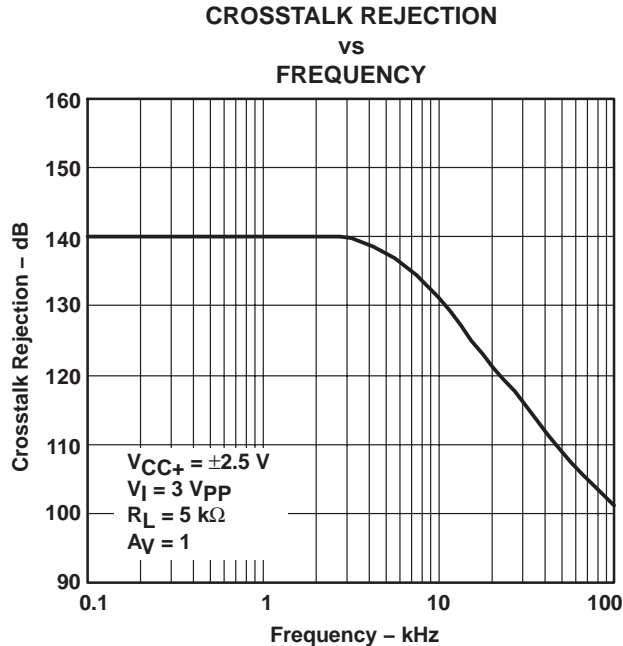

Figure 11

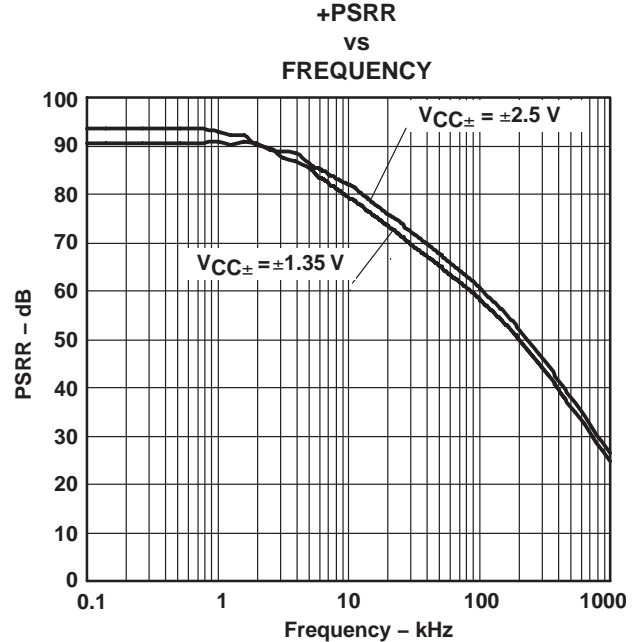
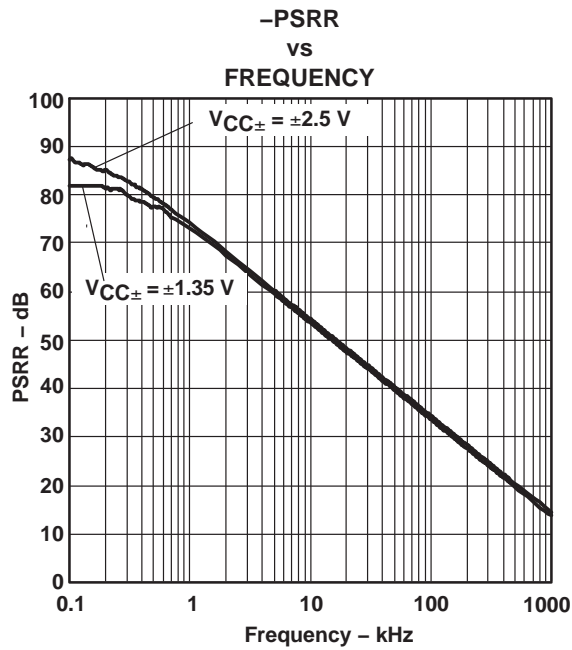

Figure 12

LMV821 SINGLE, LMV822 DUAL, LMV824 QUAD LOW-VOLTAGE, RAIL-TO-RAIL OUTPUT OPERATIONAL AMPLIFIERS

SLOS434F – FEBRUARY 2004 – REVISED OCTOBER 2004

TYPICAL CHARACTERISTICS
($T_A = 25^\circ\text{C}$, $V_{CC+} = 5\text{-V}$ Single Supply, Unless Otherwise Noted)



LMV821 SINGLE, LMV822 DUAL, LMV824 QUAD LOW-VOLTAGE, RAIL-TO-RAIL OUTPUT OPERATIONAL AMPLIFIERS

SLOS434F – FEBRUARY 2004 – REVISED OCTOBER 2004

TYPICAL CHARACTERISTICS

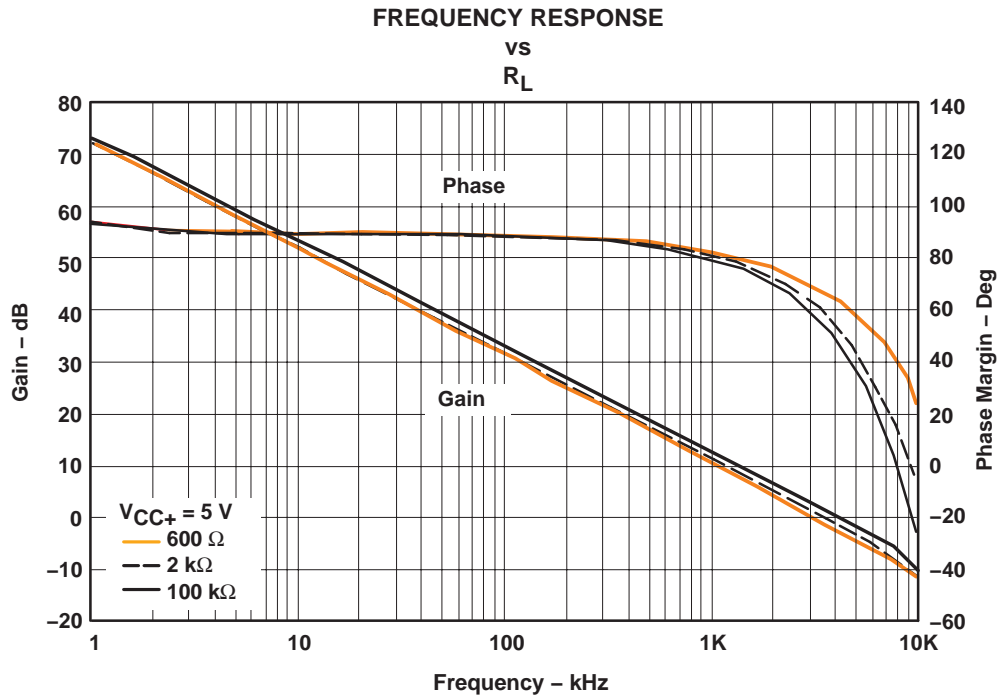

Figure 14

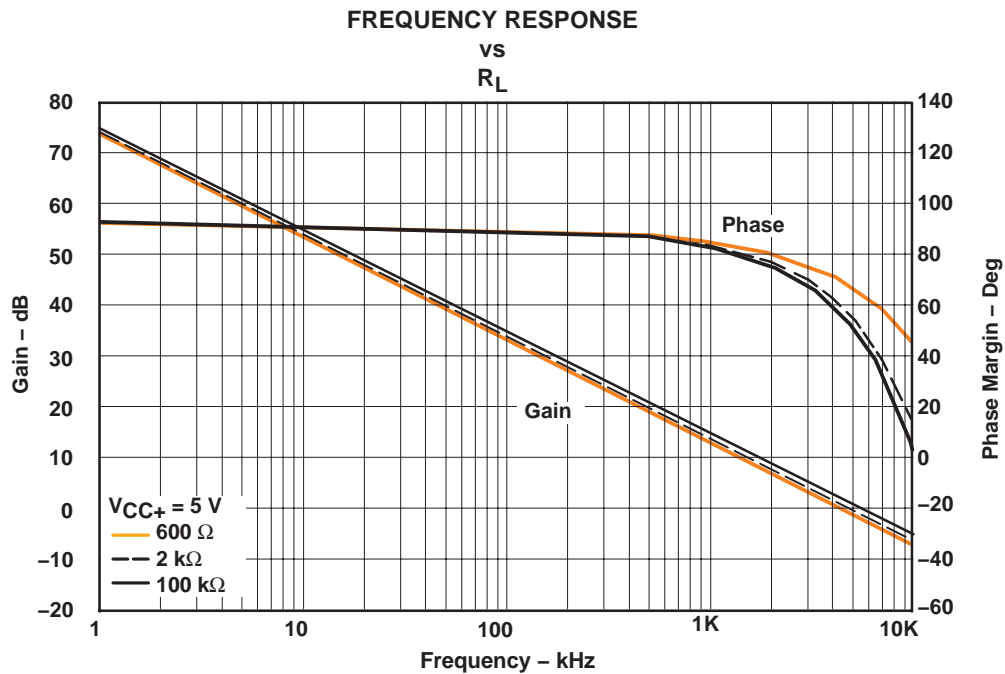
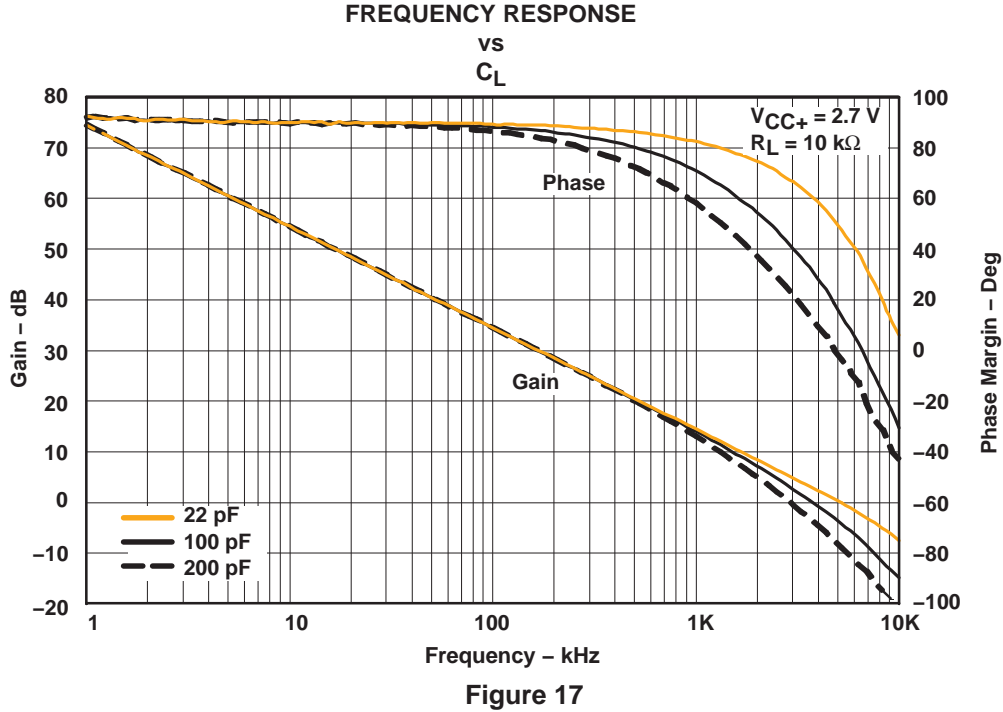
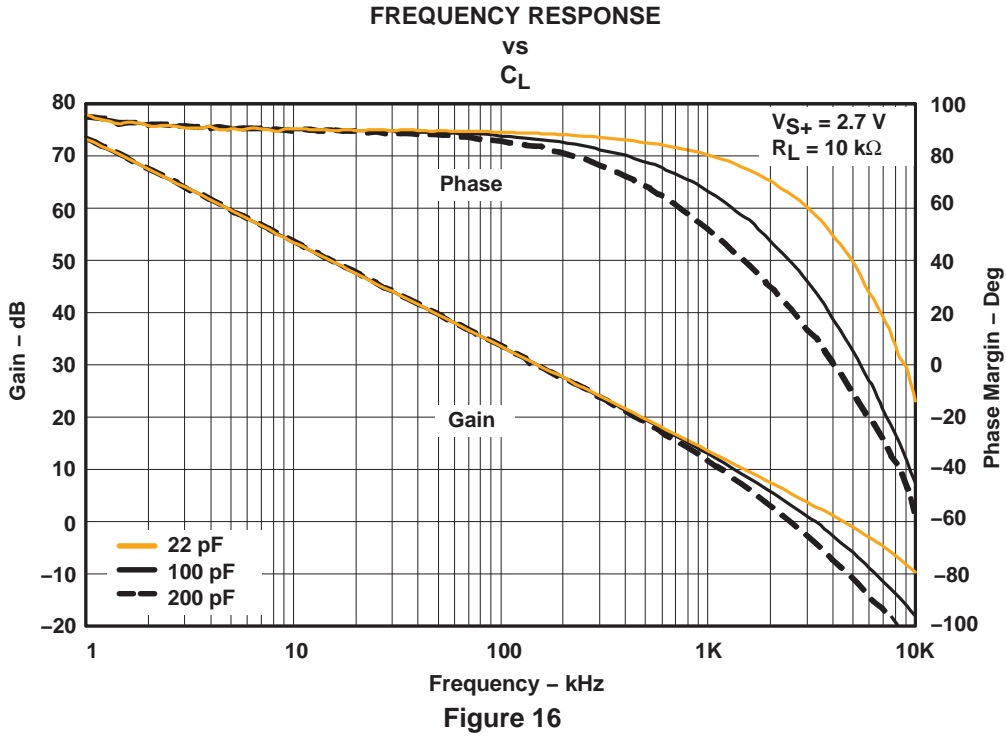

Figure 15

LMV821 SINGLE, LMV822 DUAL, LMV824 QUAD LOW-VOLTAGE, RAIL-TO-RAIL OUTPUT OPERATIONAL AMPLIFIERS

SLOS434F – FEBRUARY 2004 – REVISED OCTOBER 2004

TYPICAL CHARACTERISTICS



LMV821 SINGLE, LMV822 DUAL, LMV824 QUAD LOW-VOLTAGE, RAIL-TO-RAIL OUTPUT OPERATIONAL AMPLIFIERS

SLOS434F – FEBRUARY 2004 – REVISED OCTOBER 2004

TYPICAL CHARACTERISTICS

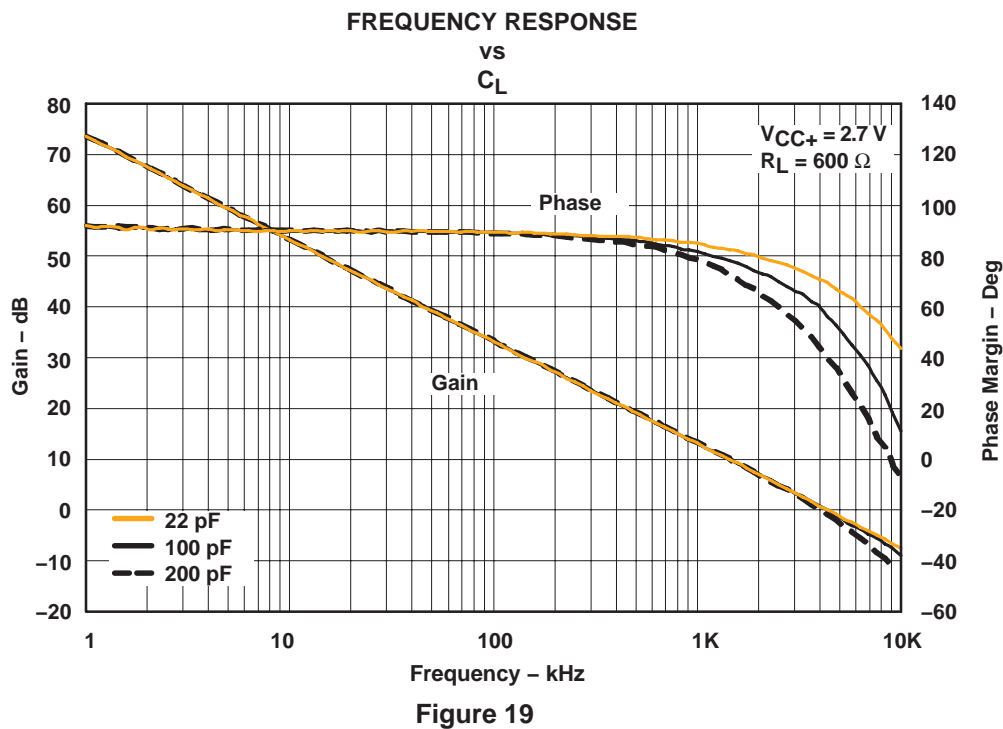
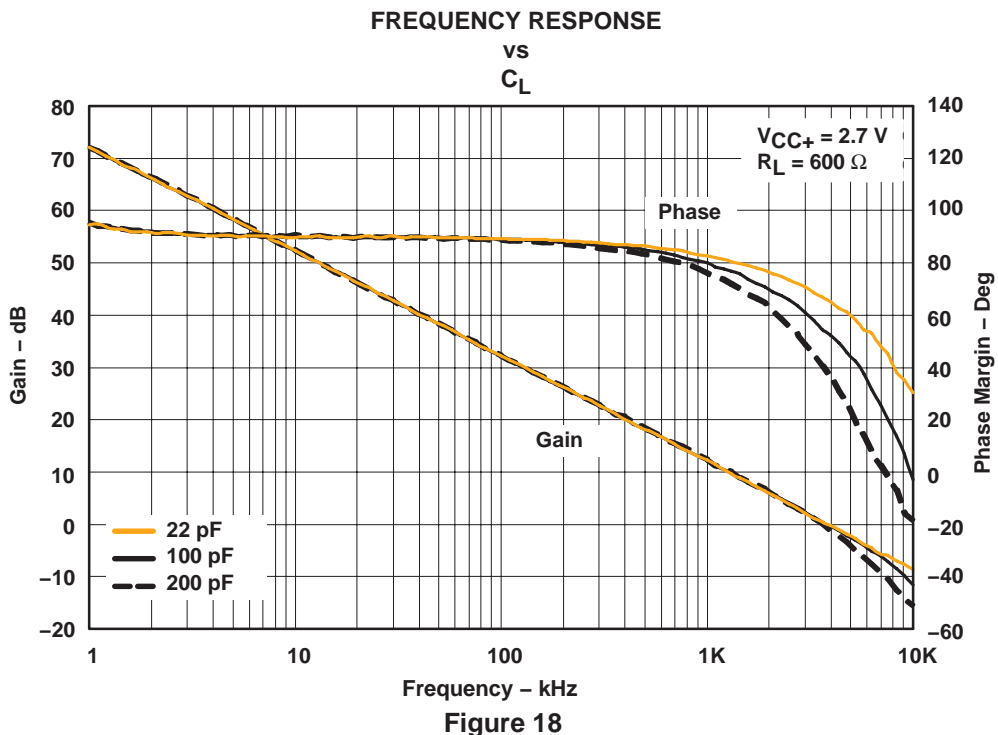

PACKAGING INFORMATION

Orderable Device	Status ⁽¹⁾	Package Type	Package Drawing	Pins	Package Qty	Eco Plan ⁽²⁾	Lead/Ball Finish	MSL Peak Temp ⁽³⁾
LMV821DBVR	ACTIVE	SOT-23	DBV	5	3000	Green (RoHS & no Sb/Br)	CU NIPDAU	Level-1-260C-UNLIM
LMV821DBVT	ACTIVE	SOT-23	DBV	5	250	Green (RoHS & no Sb/Br)	CU NIPDAU	Level-1-260C-UNLIM
LMV821DCKR	ACTIVE	SC70	DCK	5	3000	Green (RoHS & no Sb/Br)	CU NIPDAU	Level-1-260C-UNLIM
LMV821DCKT	ACTIVE	SC70	DCK	5	250	Green (RoHS & no Sb/Br)	CU NIPDAU	Level-1-260C-UNLIM
LMV821DBVR	ACTIVE	SOT-23	DBV	5	3000	Green (RoHS & no Sb/Br)	CU NIPDAU	Level-1-260C-UNLIM
LMV821DBVT	ACTIVE	SOT-23	DBV	5	250	Green (RoHS & no Sb/Br)	CU NIPDAU	Level-1-260C-UNLIM
LMV821DCKR	ACTIVE	SC70	DCK	5	3000	Green (RoHS & no Sb/Br)	CU NIPDAU	Level-1-260C-UNLIM
LMV821DCKT	ACTIVE	SC70	DCK	5	250	Green (RoHS & no Sb/Br)	CU NIPDAU	Level-1-260C-UNLIM
LMV822D	ACTIVE	SOIC	D	8	75	Pb-Free (RoHS)	CU NIPDAU	Level-2-260C-1 YEAR/ Level-1-235C-UNLIM
LMV822DGKR	ACTIVE	MSOP	DGK	8	2500	Green (RoHS & no Sb/Br)	CU NIPDAU	Level-2-260C-1YEAR
LMV822DR	ACTIVE	SOIC	D	8	2500	Pb-Free (RoHS)	CU NIPDAU	Level-2-260C-1 YEAR/ Level-1-235C-UNLIM
LMV822ID	ACTIVE	SOIC	D	8	75	Pb-Free (RoHS)	CU NIPDAU	Level-2-260C-1 YEAR/ Level-1-235C-UNLIM
LMV822IDGKR	ACTIVE	MSOP	DGK	8	2500	Green (RoHS & no Sb/Br)	CU NIPDAU	Level-2-260C-1YEAR
LMV822IDR	ACTIVE	SOIC	D	8	2500	Pb-Free (RoHS)	CU NIPDAU	Level-2-260C-1 YEAR/ Level-1-235C-UNLIM
LMV824D	ACTIVE	SOIC	D	14	50	Pb-Free (RoHS)	CU NIPDAU	Level-2-260C-1 YEAR/ Level-1-235C-UNLIM
LMV824DGVR	ACTIVE	TVSOP	DGV	14	2000	Pb-Free (RoHS)	CU NIPDAU	Level-1-250C-UNLIM
LMV824DR	ACTIVE	SOIC	D	14	2500	Pb-Free (RoHS)	CU NIPDAU	Level-2-260C-1 YEAR/ Level-1-235C-UNLIM
LMV824ID	ACTIVE	SOIC	D	14	50	Pb-Free (RoHS)	CU NIPDAU	Level-2-260C-1 YEAR/ Level-1-235C-UNLIM
LMV824IDGVR	ACTIVE	TVSOP	DGV	14	2000	Pb-Free (RoHS)	CU NIPDAU	Level-1-250C-UNLIM
LMV824IDR	ACTIVE	SOIC	D	14	2500	Pb-Free (RoHS)	CU NIPDAU	Level-2-260C-1 YEAR/ Level-1-235C-UNLIM
LMV824IPW	ACTIVE	TSSOP	PW	14	90	Pb-Free (RoHS)	CU NIPDAU	Level-1-250C-UNLIM
LMV824IPWR	ACTIVE	TSSOP	PW	14	2000	Pb-Free (RoHS)	CU NIPDAU	Level-1-250C-UNLIM
LMV824PW	ACTIVE	TSSOP	PW	14	90	Pb-Free (RoHS)	CU NIPDAU	Level-1-250C-UNLIM
LMV824PWR	ACTIVE	TSSOP	PW	14	2000	Pb-Free (RoHS)	CU NIPDAU	Level-1-250C-UNLIM

⁽¹⁾ The marketing status values are defined as follows:

ACTIVE: Product device recommended for new designs.

LIFEBUY: TI has announced that the device will be discontinued, and a lifetime-buy period is in effect.

NRND: Not recommended for new designs. Device is in production to support existing customers, but TI does not recommend using this part in a new design.

PREVIEW: Device has been announced but is not in production. Samples may or may not be available.

OBSOLETE: TI has discontinued the production of the device.

(2) Eco Plan - May not be currently available - please check <http://www.ti.com/productcontent> for the latest availability information and additional product content details.

None: Not yet available Lead (Pb-Free).

Pb-Free (RoHS): TI's terms "Lead-Free" or "Pb-Free" mean semiconductor products that are compatible with the current RoHS requirements for all 6 substances, including the requirement that lead not exceed 0.1% by weight in homogeneous materials. Where designed to be soldered at high temperatures, TI Pb-Free products are suitable for use in specified lead-free processes.

Green (RoHS & no Sb/Br): TI defines "Green" to mean "Pb-Free" and in addition, uses package materials that do not contain halogens, including bromine (Br) or antimony (Sb) above 0.1% of total product weight.

(3) MSL, Peak Temp. -- The Moisture Sensitivity Level rating according to the JEDEC industry standard classifications, and peak solder temperature.

Important Information and Disclaimer:The information provided on this page represents TI's knowledge and belief as of the date that it is provided. TI bases its knowledge and belief on information provided by third parties, and makes no representation or warranty as to the accuracy of such information. Efforts are underway to better integrate information from third parties. TI has taken and continues to take reasonable steps to provide representative and accurate information but may not have conducted destructive testing or chemical analysis on incoming materials and chemicals. TI and TI suppliers consider certain information to be proprietary, and thus CAS numbers and other limited information may not be available for release.

In no event shall TI's liability arising out of such information exceed the total purchase price of the TI part(s) at issue in this document sold by TI to Customer on an annual basis.

DGV (R-PDSO-G**)

PLASTIC SMALL-OUTLINE

24 PINS SHOWN



- NOTES: A. All linear dimensions are in millimeters.
 B. This drawing is subject to change without notice.
 C. Body dimensions do not include mold flash or protrusion, not to exceed 0,15 per side.
 D. Falls within JEDEC: 24/48 Pins – MO-153
 14/16/20/56 Pins – MO-194

DBV (R-PDSO-G5)

PLASTIC SMALL-OUTLINE PACKAGE

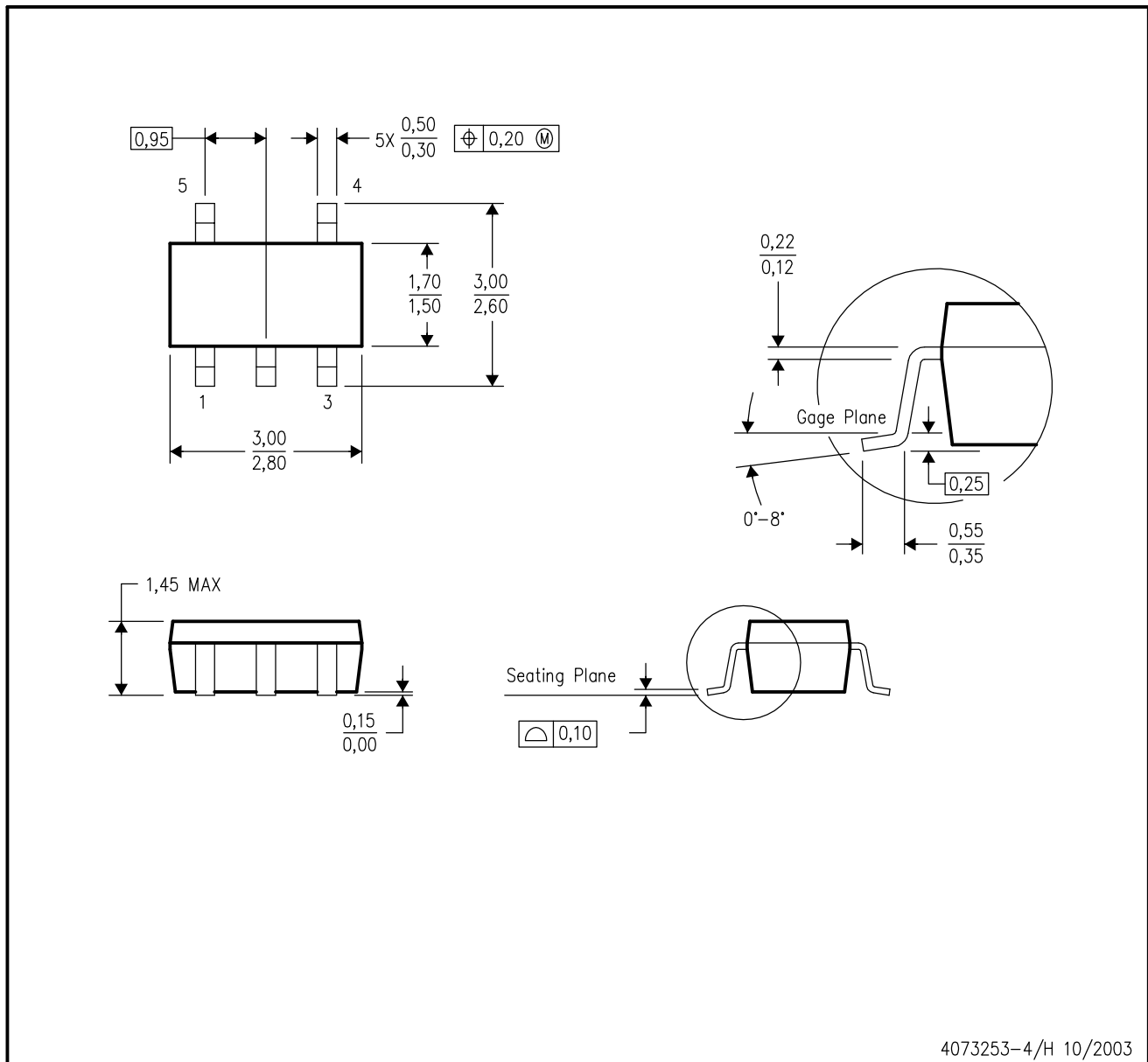

4073253-4/H 10/2003

- NOTES:
- A. All linear dimensions are in millimeters.
 - B. This drawing is subject to change without notice.
 - C. Body dimensions do not include mold flash or protrusion.
 - D. Falls within JEDEC MO-178 Variation AA.

DCK (R-PDSO-G5)

PLASTIC SMALL-OUTLINE PACKAGE



- NOTES: A. All linear dimensions are in millimeters.
 B. This drawing is subject to change without notice.
 C. Body dimensions do not include mold flash or protrusion.
 D. Falls within JEDEC MO-203

DGK (S-PDSO-G8)

PLASTIC SMALL-OUTLINE PACKAGE

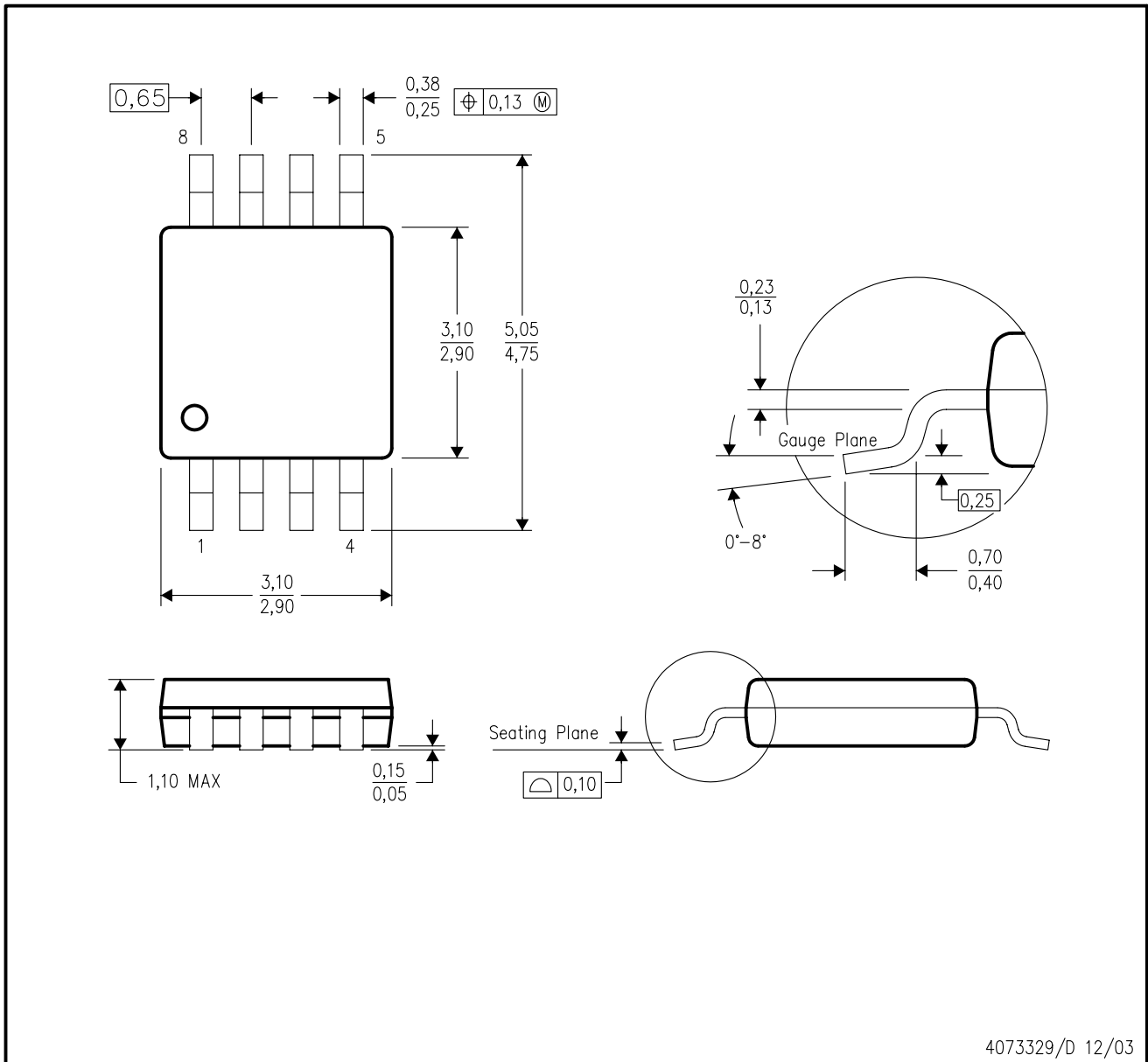

- NOTES:
- A. All linear dimensions are in millimeters.
 - B. This drawing is subject to change without notice.
 - C. Body dimensions do not include mold flash or protrusion.
 - D. Falls within JEDEC MO-187 variation AA.

D (R-PDSO-G14)

PLASTIC SMALL-OUTLINE PACKAGE



- NOTES:
- A. All linear dimensions are in inches (millimeters).
 - B. This drawing is subject to change without notice.
 - C. Body dimensions do not include mold flash or protrusion not to exceed 0.006 (0,15).
 - D. Falls within JEDEC MS-012 variation AB.

D (R-PDSO-G8)

PLASTIC SMALL-OUTLINE PACKAGE

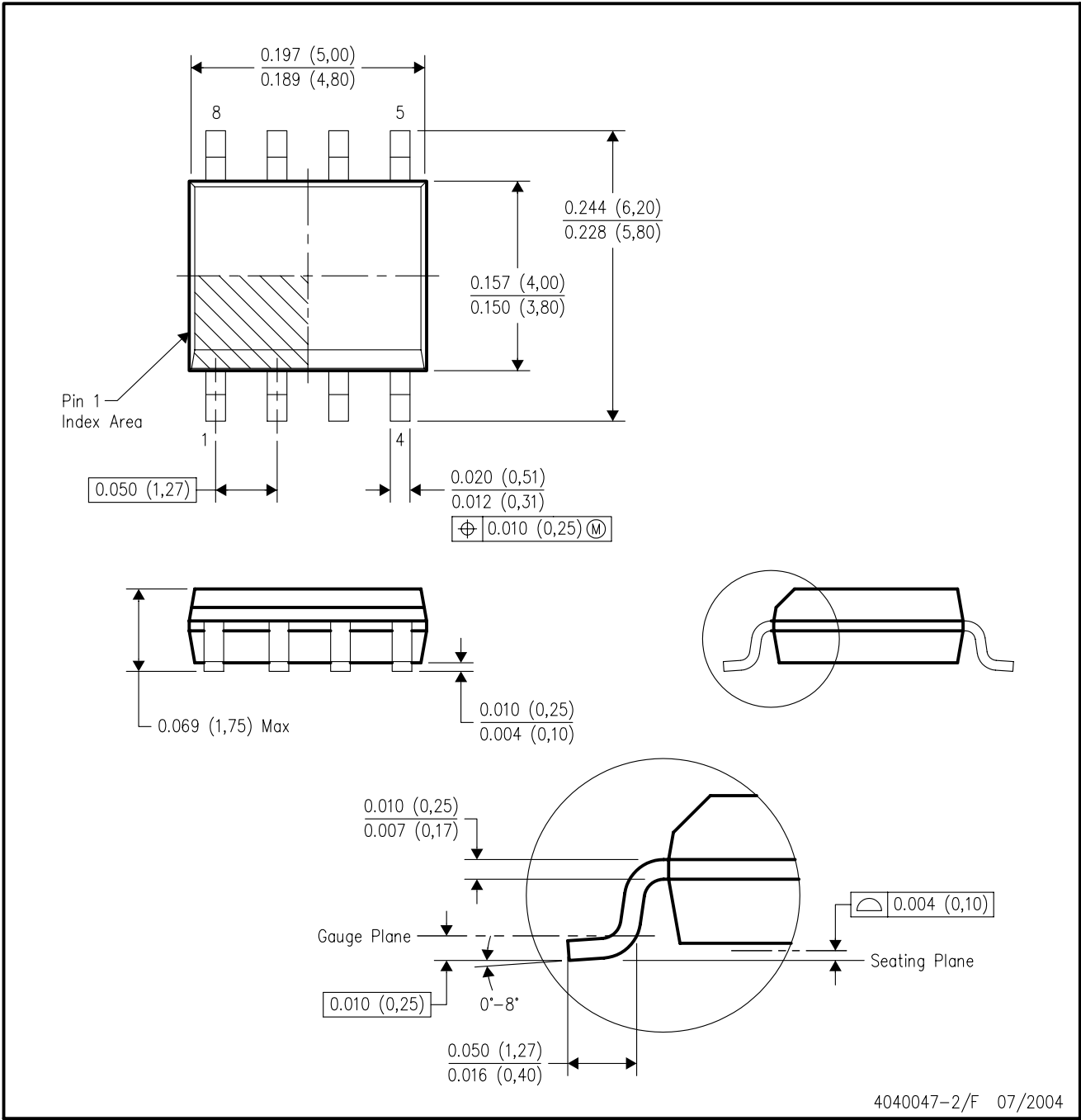

- NOTES:
- A. All linear dimensions are in inches (millimeters).
 - B. This drawing is subject to change without notice.
 - C. Body dimensions do not include mold flash or protrusion not to exceed 0.006 (0,15).
 - D. Falls within JEDEC MS-012 variation AA.

PW (R-PDSO-G**)

PLASTIC SMALL-OUTLINE PACKAGE

14 PINS SHOWN



4040064/F 01/97

- NOTES: A. All linear dimensions are in millimeters.
 B. This drawing is subject to change without notice.
 C. Body dimensions do not include mold flash or protrusion not to exceed 0,15.
 D. Falls within JEDEC MO-153

IMPORTANT NOTICE

Texas Instruments Incorporated and its subsidiaries (TI) reserve the right to make corrections, modifications, enhancements, improvements, and other changes to its products and services at any time and to discontinue any product or service without notice. Customers should obtain the latest relevant information before placing orders and should verify that such information is current and complete. All products are sold subject to TI's terms and conditions of sale supplied at the time of order acknowledgment.

TI warrants performance of its hardware products to the specifications applicable at the time of sale in accordance with TI's standard warranty. Testing and other quality control techniques are used to the extent TI deems necessary to support this warranty. Except where mandated by government requirements, testing of all parameters of each product is not necessarily performed.

TI assumes no liability for applications assistance or customer product design. Customers are responsible for their products and applications using TI components. To minimize the risks associated with customer products and applications, customers should provide adequate design and operating safeguards.

TI does not warrant or represent that any license, either express or implied, is granted under any TI patent right, copyright, mask work right, or other TI intellectual property right relating to any combination, machine, or process in which TI products or services are used. Information published by TI regarding third-party products or services does not constitute a license from TI to use such products or services or a warranty or endorsement thereof. Use of such information may require a license from a third party under the patents or other intellectual property of the third party, or a license from TI under the patents or other intellectual property of TI.

Reproduction of information in TI data books or data sheets is permissible only if reproduction is without alteration and is accompanied by all associated warranties, conditions, limitations, and notices. Reproduction of this information with alteration is an unfair and deceptive business practice. TI is not responsible or liable for such altered documentation.

Resale of TI products or services with statements different from or beyond the parameters stated by TI for that product or service voids all express and any implied warranties for the associated TI product or service and is an unfair and deceptive business practice. TI is not responsible or liable for any such statements.

Following are URLs where you can obtain information on other Texas Instruments products and application solutions:

Products		Applications	
Amplifiers	amplifier.ti.com	Audio	www.ti.com/audio
Data Converters	dataconverter.ti.com	Automotive	www.ti.com/automotive
DSP	dsp.ti.com	Broadband	www.ti.com/broadband
Interface	interface.ti.com	Digital Control	www.ti.com/digitalcontrol
Logic	logic.ti.com	Military	www.ti.com/military
Power Mgmt	power.ti.com	Optical Networking	www.ti.com/opticalnetwork
Microcontrollers	microcontroller.ti.com	Security	www.ti.com/security
		Telephony	www.ti.com/telephony
		Video & Imaging	www.ti.com/video
		Wireless	www.ti.com/wireless

Mailing Address: Texas Instruments
Post Office Box 655303 Dallas, Texas 75265