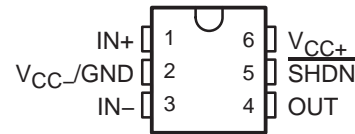


# LMV981 SINGLE, LMV982 DUAL 1.8-V OPERATIONAL AMPLIFIERS WITH RAIL-TO-RAIL INPUT AND OUTPUT AND SHUTDOWN

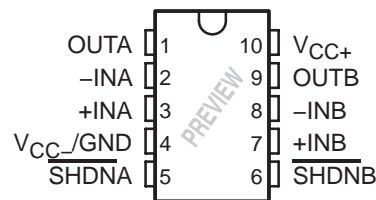
SLOS440D – AUGUST 2004 – REVISED FEBRUARY 2005

- 1.8-V, 2.7-V, and 5-V Specifications
- Rail-to-Rail Output Swing
  - 600-Ω Load . . . 80 mV From Rail
  - 2-kΩ Load . . . 30 mV From Rail
- $V_{ICR}$  . . . 200 mV Beyond Rails
- Gain Bandwidth . . . 1.4 MHz
- Supply Current . . . 100  $\mu$ A/Amplifier
- Max  $V_{IO}$  . . . 4 mV
- Turn-On Time From Shutdown . . . 8.4  $\mu$ s
- Space-Saving Packages
  - LMV981: SOT-23-6 and SC-70
  - LMV982: MSOP and VSSOP
- Applications
  - Industrial (Utility/Energy Metering)
  - Automotive
  - Communications (Optical Telecom, Data/Voice Cable Modems)
  - Consumer Electronics (PDAs, PCs, CDR/W, Portable Audio)
  - Supply-Current Monitoring
  - Battery Monitoring

LMV981 . . . DBV (SOT23-6) OR DCK (SC-70) PACKAGE  
(TOP VIEW)



LMV982 . . . DGS (VSSOP/MSOP) PACKAGE  
(TOP VIEW)



## description/ordering information

The LMV981 and LMV982 devices are low-voltage, low-power operational amplifiers that are well suited for today's low-voltage and/or portable applications. Specified for operation of 1.8 V to 5 V, they can be used in portable applications that are powered from a single-cell Li-ion or two-cell batteries. They have rail-to-rail input and output capability for maximum signal swings in low-voltage applications. The LMV98x input common-mode voltage extends 200 mV beyond the rails for increased flexibility. The output can swing rail-to-rail unloaded and typically can reach 80 mV from the rails, while driving a 600-Ω load (at 1.8-V operation).

## ORDERING INFORMATION

$T_A$	PACKAGE†		ORDERABLE PART NUMBER	TOP-SIDE MARKING‡	
–40°C to 125°C	Single	SOT (SOT-23)	Reel of 3000	LMV981IDBVR	RBA_
			Reel of 250	LMV981IDBVT	PREVIEW
		SOT (SC-70)	Reel of 3000	LMV981IDCKR	R7_
			Reel of 250	LMV981IDCKT	PREVIEW
	Dual	MSOP/VSSOP (DGS)	Reel of 2500	LMV982IDGSR	PREVIEW
			Reel of 250	LMV982IDGST	

† Package drawings, standard packing quantities, thermal data, symbolization, and PCB design guidelines are available at [www.ti.com/sc/package](http://www.ti.com/sc/package).

‡ DBV/DCK: The actual top-side marking has one additional character that designates the assembly/test site.



Please be aware that an important notice concerning availability, standard warranty, and use in critical applications of Texas Instruments semiconductor products and disclaimers thereto appears at the end of this data sheet.

PRODUCTION DATA information is current as of publication date. Products conform to specifications per the terms of Texas Instruments standard warranty. Production processing does not necessarily include testing of all parameters.

 **TEXAS  
INSTRUMENTS**

POST OFFICE BOX 655303 • DALLAS, TEXAS 75265

Copyright © 2005, Texas Instruments Incorporated

# LMV981 SINGLE, LMV982 DUAL 1.8-V OPERATIONAL AMPLIFIERS WITH RAIL-TO-RAIL INPUT AND OUTPUT AND SHUTDOWN

SLOS440D – AUGUST 2004 – REVISED FEBRUARY 2005

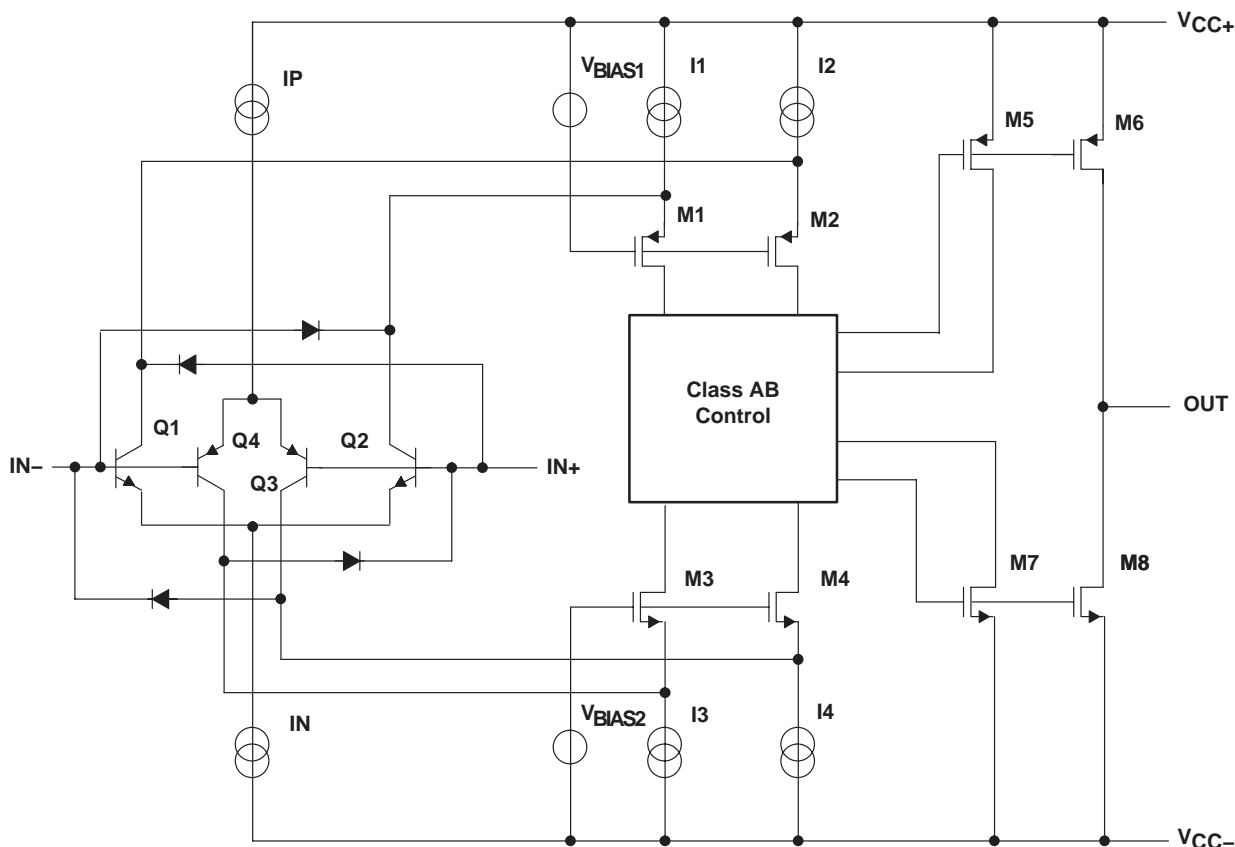
## description/ordering information (continued)

The LMV981 and LMV982 devices offer shutdown capability for additional power savings. Pulling the SHDN pin low puts the amplifiers in shutdown, where only 0.156  $\mu\text{A}$  typically is consumed from a 1.8-V supply. In normal operation with the same 1.8-V supply, the devices typically consume a quiescent current of 103  $\mu\text{A}$  per channel, and yet they are able to achieve excellent electrical specifications, such as 101-dB open-loop DC gain and 1.4-MHz-gain bandwidth. Furthermore, the amplifiers offer good output drive characteristics, with the ability to drive a 600- $\Omega$  load and 1000-pF capacitance, with minimal ringing.

The LMV981 and LMV982 devices are offered in the latest packaging technology to meet the most demanding space-constraint applications. The LMV981 is offered in standard SOT-23 and SC-70 packages. The LMV982 is available in the 10-pin MSOP package.

The LMV98x devices are characterized for operation from  $-40^{\circ}\text{C}$  to  $125^{\circ}\text{C}$ , making them universally suited for commercial, industrial, and automotive applications.

## simplified schematic



# LMV981 SINGLE, LMV982 DUAL 1.8-V OPERATIONAL AMPLIFIERS WITH RAIL-TO-RAIL INPUT AND OUTPUT AND SHUTDOWN

SLOS440D – AUGUST 2004 – REVISED FEBRUARY 2005

## absolute maximum ratings over free-air temperature range (unless otherwise noted)†

Supply voltage, $V_{CC+} - V_{CC-}$ (see Note 1) .....	5.5 V
Differential input voltage, $V_{ID}$ (see Note 2) .....	Supply voltage
Input voltage range, $V_I$ (either input) .....	$V_{CC-} - 0.2\text{ V}$ to $V_{CC+} + 0.2\text{ V}$
Duration of output short circuit (one amplifier) to $V_{CC\pm}$ (see Notes 3 and 4) .....	Unlimited
Package thermal impedance, $\theta_{JA}$ (see Notes 4 and 5): DBV package .....	165°C/W
DCK package .....	259°C/W
DGS package .....	165°C/W
Operating virtual junction temperature, $T_J$ .....	150°C
Storage temperature range, $T_{Stg}$ .....	–65 to 150°C

† Stresses beyond those listed under “absolute maximum ratings” may cause permanent damage to the device. These are stress ratings only, and functional operation of the device at these or any other conditions beyond those indicated under “recommended operating conditions” is not implied. Exposure to absolute-maximum-rated conditions for extended periods may affect device reliability.

- NOTES:
1. All voltage values (except differential voltages and  $V_{CC}$  specified for the measurement of  $I_{OS}$ ) are with respect to the network GND.
  2. Differential voltages are at IN+ with respect to IN–.
  3. Applies to both single-supply and split-supply operation. Continuous short-circuit operation at elevated ambient temperature can result in exceeding the maximum-allowed junction temperature of 150°C. Output currents in excess of 45 mA over long term may adversely affect reliability.
  4. Maximum power dissipation is a function of  $T_J(\text{max})$ ,  $\theta_{JA}$ , and  $T_A$ . The maximum allowable power dissipation at any allowable ambient temperature is  $P_D = (T_J(\text{max}) - T_A)/\theta_{JA}$ . Operating at the absolute maximum  $T_J$  of 150°C can affect reliability.
  5. The package thermal impedance is calculated in accordance with JESD 51-7.

## recommended operating conditions

	MIN	MAX	UNIT
$V_{CC}$ Supply voltage ( $V_{CC+} - V_{CC-}$ )	1.8	5	V
$T_A$ Operating free-air temperature	–40	125	°C

## ESD protection

TEST CONDITIONS	TYP	UNIT
Human-Body Model	2000	V
Machine Model	200	V



# LMV981 SINGLE, LMV982 DUAL 1.8-V OPERATIONAL AMPLIFIERS WITH RAIL-TO-RAIL INPUT AND OUTPUT AND SHUTDOWN

SLOS440D – AUGUST 2004 – REVISED FEBRUARY 2005

electrical characteristics at  $T_A = 25^\circ\text{C}$ ,  $V_{CC+} = 1.8\text{ V}$ ,  $V_{CC-} = 0\text{ V}$ ,  $V_{IC} = V_{CC+}/2$ ,  $V_O = V_{CC+}/2$ ,  $R_L > 1\text{ M}\Omega$ , and SHDN tied to  $V_{CC+}$  (unless otherwise noted)

PARAMETER		TEST CONDITIONS		$T_A$	MIN	TYP	MAX	UNIT		
$V_{IO}$	Input offset voltage	LMV981 (single)		25°C		1	4	mV		
				Full range					6	
		LMV982 (dual)		25°C		1	5.5			
				Full range					7.5	
$\alpha_{V_{IO}}$	Average temperature coefficient of input offset voltage			25°C		5.5		$\mu\text{V}/^\circ\text{C}$		
$I_{IB}$	Input bias current	$V_{IC} = V_{CC+} - 0.8\text{ V}$		25°C		15	35	nA		
				25°C			50			
				Full range					75	
$I_{IO}$	Input offset current			25°C		13	25	nA		
				Full range					40	
$I_{CC}$	Supply current (per channel)			25°C		103	185	$\mu\text{A}$		
				Full range					205	
				In shutdown		25°C			0.156	1
						Full range				
				25°C		0.178	3.5			
				Full range					5	
$\text{CMRR}$	Common-mode rejection ratio	$0 \leq V_{IC} \leq 0.6\text{ V}$ , $1.4 \leq V_{IC} \leq 1.8\text{ V}$		25°C	60	78	dB			
				-40°C to 85°C		55				
		$0.2 \leq V_{IC} \leq 0.6\text{ V}$ , $1.4 \leq V_{IC} \leq 1.6\text{ V}$		-40°C to 125°C		55				
				25°C	50	72				
$k_{SVR}$	Supply-voltage rejection ratio	$1.8 \leq V_{CC+} \leq 5\text{ V}$		25°C	75	100	dB			
				Full range		70				
$V_{ICR}$	Common-mode input voltage range	$\text{CMRR} \geq 50\text{ dB}$		25°C	$V_{CC-} - 0.2$	-0.2 to 2.1	$V_{CC+} + 0.2$	V		
				-40°C to 85°C		$V_{CC-}$			$V_{CC+}$	
				-40°C to 125°C		$V_{CC-} + 0.2$			$V_{CC+} - 0.2$	
$A_V$	Large-signal voltage gain	LMV981		$R_L = 600\ \Omega$ to 0.9 V, $V_O = 0.2\text{ V}$ to 1.6 V, $V_{IC} = 0.5\text{ V}$		25°C	77	101	dB	
				Full range		73				
				$R_L = 2\text{ k}\Omega$ to 0.9 V, $V_O = 0.2\text{ V}$ to 1.6 V, $V_{IC} = 0.5\text{ V}$		25°C	80	105		
						Full range		75		
		LMV982		$R_L = 600\ \Omega$ to 0.9 V, $V_O = 0.2\text{ V}$ to 1.6 V, $V_{IC} = 0.5\text{ V}$		25°C	75	90		
				Full range		72				
		$R_L = 2\text{ k}\Omega$ to 0.9 V, $V_O = 0.2\text{ V}$ to 1.6 V, $V_{IC} = 0.5\text{ V}$		25°C	78	100				
		Full range		75						



**LMV981 SINGLE, LMV982 DUAL  
1.8-V OPERATIONAL AMPLIFIERS  
WITH RAIL-TO-RAIL INPUT AND OUTPUT AND SHUTDOWN**

SLOS440D – AUGUST 2004 – REVISED FEBRUARY 2005

electrical characteristics at  $T_A = 25^\circ\text{C}$ ,  $V_{CC+} = 1.8\text{ V}$ ,  $V_{CC-} = 0\text{ V}$ ,  $V_{IC} = V_{CC+}/2$ ,  $V_O = V_{CC+}/2$ ,  $R_L > 1\text{ M}\Omega$ , and SHDN tied to  $V_{CC+}$  (unless otherwise noted) (continued)

PARAMETER		TEST CONDITIONS	$T_A$	MIN	TYP	MAX	UNIT	
$V_O$	Output swing	$R_L = 600\ \Omega$ to $0.9\text{ V}$ , $V_{ID} = \pm 100\text{ mV}$	High level	$25^\circ\text{C}$	1.65	1.72	V	
				Full range	1.63			
			Low level	$25^\circ\text{C}$		0.077		0.105
				Full range				0.12
		$R_L = 2\text{ k}\Omega$ to $0.9\text{ V}$ , $V_{ID} = \pm 100\text{ mV}$	High level	$25^\circ\text{C}$	1.75	1.77		
				Full range	1.74			
			Low level	$25^\circ\text{C}$		0.024		0.035
				Full range				0.04
$I_{OS}$	Output short-circuit current	$V_O = 0\text{ V}$ , $V_{ID} = 100\text{ mV}$	Sourcing	$25^\circ\text{C}$	4	8	mA	
				Full range	3.3			
		$V_O = 1.8\text{ V}$ , $V_{ID} = -100\text{ mV}$	Sinking	$25^\circ\text{C}$	7	9		
				Full range	5			
$T_{on}$	Turn-on time from shutdown		$25^\circ\text{C}$		19	$\mu\text{s}$		
$V_{SHDN}$	Turn-on voltage to enable part		$25^\circ\text{C}$		1.0	V		
	Turn-off voltage				0.55			
GBW	Gain bandwidth product		$25^\circ\text{C}$		1.4	MHz		
SR	Slew rate	See Note 6	$25^\circ\text{C}$		0.35	$\text{V}/\mu\text{s}$		
$\Phi_m$	Phase margin		$25^\circ\text{C}$		67	deg		
	Gain margin		$25^\circ\text{C}$		7	dB		
$V_n$	Equivalent input noise voltage	$f = 1\text{ kHz}$ , $V_{IC} = 0.5\text{ V}$	$25^\circ\text{C}$		60	$\text{nV}/\sqrt{\text{Hz}}$		
$I_n$	Equivalent input noise current	$f = 1\text{ kHz}$	$25^\circ\text{C}$		0.06	$\text{pA}/\sqrt{\text{Hz}}$		
THD	Total harmonic distortion	$f = 1\text{ kHz}$ , $A_V = 1$ , $R_L = 600\ \Omega$ , $V_{ID} = 1\text{ V}_{PP}$	$25^\circ\text{C}$		0.023	%		
	Amp-to-amp isolation	See Note 7	$25^\circ\text{C}$		123	dB		

- NOTES: 6. Number specified is the slower of the positive and negative slew rates.  
7. Input referred,  $V_{CC+} = 5\text{ V}$  and  $R_L = 100\text{ k}\Omega$  connected to  $2.5\text{ V}$ . Each amp is excited in turn with a 1-kHz signal to produce  $V_O = 3\text{ V}_{PP}$ .

# LMV981 SINGLE, LMV982 DUAL 1.8-V OPERATIONAL AMPLIFIERS WITH RAIL-TO-RAIL INPUT AND OUTPUT AND SHUTDOWN

SLOS440D – AUGUST 2004 – REVISED FEBRUARY 2005

electrical characteristics at  $T_A = 25^\circ\text{C}$ ,  $V_{CC+} = 2.7\text{ V}$ ,  $V_{CC-} = 0\text{ V}$ ,  $V_{IC} = V_{CC+}/2$ ,  $V_O = V_{CC+}/2$ ,  $R_L > 1\text{ M}\Omega$ , and SHDN tied to  $V_{CC+}$  (unless otherwise noted)

PARAMETER		TEST CONDITIONS		$T_A$	MIN	TYP	MAX	UNIT	
$V_{IO}$	Input offset voltage	LMV981 (single)		25°C		1	4	mV	
				Full range					6
		LMV982 (dual)		25°C		1	6		
				Full range					7.5
$\alpha_{V_{IO}}$	Average temperature coefficient of input offset voltage			25°C		5.5		$\mu\text{V}/^\circ\text{C}$	
$I_{IB}$	Input bias current	$V_{IC} = V_{CC+} - 0.8\text{ V}$		25°C		15	35	nA	
				25°C			50		
				Full range					75
$I_{IO}$	Input offset current			25°C		8	25	nA	
				Full range					40
$I_{CC}$	Supply current (per channel)			25°C		105	190	$\mu\text{A}$	
				Full range					210
		In shutdown	LMV981	25°C		0.61	1		
				Full range					2
			LMV982	25°C		0.101	3.5		
				Full range					5
CMRR	Common-mode rejection ratio	$0 \leq V_{IC} \leq 1.5\text{ V}$ , $2.3\text{ V} \leq V_{IC} \leq 2.7\text{ V}$		25°C	60	81	dB		
				-40°C to 85°C		55			
		$0.2 \leq V_{IC} \leq 1.5\text{ V}$ , $2.3\text{ V} \leq V_{IC} \leq 2.5\text{ V}$		-40°C to 125°C		55			
				25°C		50		74	
$k_{SVR}$	Supply-voltage rejection ratio	$1.8\text{ V} \leq V_{CC+} \leq 5\text{ V}$ , $V_{IC} = 0.5\text{ V}$		25°C	75	100	dB		
				Full range		70			
$V_{ICR}$	Common-mode input voltage range	CMRR $\geq 50\text{ dB}$		25°C	$V_{CC-} - 0.2$	-0.2 to 3.0	$V_{CC+} + 0.2$	V	
				-40°C to 85°C		$V_{CC-}$			$V_{CC+}$
				-40°C to 125°C		$V_{CC-} + 0.2$			$V_{CC+} - 0.2$
$A_V$	Large-signal voltage gain	LMV981	$R_L = 600\ \Omega$ to 1.35 V, $V_O = 0.2\text{ V}$ to 2.5 V	25°C	87	104	dB		
				Full range		86			
			LMV982	$R_L = 2\text{ k}\Omega$ to 1.35 V, $V_O = 0.2\text{ V}$ to 2.5 V	25°C	92		110	
		Full range			91				
		$R_L = 600\ \Omega$ to 1.35 V, $V_O = 0.2\text{ V}$ to 2.5 V		25°C	78	90			
			Full range		75				
		$R_L = 2\text{ k}\Omega$ to 1.35 V, $V_O = 0.2\text{ V}$ to 2.5 V	25°C	81	100				
			Full range		78				



**LMV981 SINGLE, LMV982 DUAL  
1.8-V OPERATIONAL AMPLIFIERS  
WITH RAIL-TO-RAIL INPUT AND OUTPUT AND SHUTDOWN**

SLOS440D – AUGUST 2004 – REVISED FEBRUARY 2005

characteristics at  $T_A = 25^\circ\text{C}$ ,  $V_{CC+} = 2.7\text{ V}$ ,  $V_{CC-} = 0\text{ V}$ ,  $V_{IC} = V_{CC+}/2$ ,  $V_O = V_{CC+}/2$ ,  $R_L > 1\text{ M}\Omega$ , and SHDN tied to  $V_{CC+}$  (unless otherwise noted) (continued)

PARAMETER		TEST CONDITIONS	$T_A$	MIN	TYP	MAX	UNIT	
$V_O$	Output swing	$R_L = 600\ \Omega$ to 1.35 V, $V_{ID} = \pm 100\text{ mV}$	High level	25°C	2.55	2.62	V	
				Full range	2.53			
			Low level	25°C		0.083		0.11
				Full range				0.13
		$R_L = 2\text{ k}\Omega$ to 1.35 V, $V_{ID} = \pm 100\text{ mV}$	High level	25°C	2.65	2.675		
				Full range	2.64			
			Low level	25°C		0.025		0.04
				Full range				0.045
$I_{OS}$	Output short-circuit current	$V_O = 0\text{ V}$ , $V_{ID} = 100\text{ mV}$	Sourcing	25°C	20	30	mA	
				Full range	15			
		$V_O = 2.7\text{ V}$ , $V_{ID} = -100\text{ mV}$	Sinking	25°C	18	25		
				Full range	12			
$T_{on}$	Turn-on time from shutdown		25°C		12.5	$\mu\text{s}$		
$V_{SHDN}$	Turn-on voltage to enable part		25°C		1.9	V		
	Turn-off voltage				0.8			
GBW	Gain bandwidth product		25°C		1.4	MHz		
SR	Slew rate	See Note 6	25°C		0.4	V/ $\mu\text{s}$		
$\Phi_m$	Phase margin		25°C		70	deg		
	Gain margin				7.5			
$V_n$	Equivalent input noise voltage	$f = 1\text{ kHz}$ , $V_{IC} = 0.5\text{ V}$	25°C		57	nV/ $\sqrt{\text{Hz}}$		
$I_n$	Equivalent input noise current	$f = 1\text{ kHz}$	25°C		0.082	pA/ $\sqrt{\text{Hz}}$		
THD	Total harmonic distortion	$f = 1\text{ kHz}$ , $A_V = 1$ , $R_L = 600\ \Omega$ , $V_{ID} = 1\text{ V}_{PP}$	25°C		0.022	%		
	Amp-to-amp isolation	See Note 7			123			

- NOTES: 6. Number specified is the slower of the positive and negative slew rates.  
7. Input referred,  $V_{CC+} = 5\text{ V}$  and  $R_L = 100\text{ k}\Omega$  connected to 2.5 V. Each amp is excited in turn with a 1-kHz signal to produce  $V_O = 3\text{ V}_{PP}$ .

# LMV981 SINGLE, LMV982 DUAL 1.8-V OPERATIONAL AMPLIFIERS WITH RAIL-TO-RAIL INPUT AND OUTPUT AND SHUTDOWN

SLOS440D – AUGUST 2004 – REVISED FEBRUARY 2005

electrical characteristics at  $T_A = 25^\circ\text{C}$ ,  $V_{CC+} = 5\text{ V}$ ,  $V_{CC-} = 0\text{ V}$ ,  $V_{IC} = V_{CC+}/2$ ,  $V_O = V_{CC+}/2$ ,  $R_L > 1\text{ M}\Omega$ , and SHDN tied to  $V_{CC+}$  (unless otherwise noted)

PARAMETER		TEST CONDITIONS		$T_A$	MIN	TYP	MAX	UNIT	
$V_{IO}$	Input offset voltage	LMV981 (single)		25°C		1	4	mV	
				Full range					6
		LMV982 (dual)		25°C		1	5.5		
				Full range					7.5
$\alpha_{V_{IO}}$	Average temperature coefficient of input offset voltage			25°C		5.5		$\mu\text{V}/^\circ\text{C}$	
$I_{IB}$	Input bias current	$V_{IC} = V_{CC+} - 0.8\text{ V}$		25°C		15	35	nA	
				25°C			50		
				Full range					75
$I_{IO}$	Input offset current			25°C		9	25	nA	
				Full range					40
$I_{CC}$	Supply current (per channel)			25°C		116	210	$\mu\text{A}$	
				Full range					230
		In shutdown	LMV981	25°C		0.201	1		
				Full range					2
			LMV982	25°C		0.302	3.5		
				Full range					5
CMRR	Common-mode rejection ratio	$0 \leq V_{IC} \leq 3.8\text{ V}$ , $4.6\text{ V} \leq V_{IC} \leq 5\text{ V}$		25°C	60	86	dB		
				-40°C to 85°C		55			
		$0.3 \leq V_{IC} \leq 3.8\text{ V}$ , $4.6\text{ V} \leq V_{IC} \leq 4.7\text{ V}$		-40°C to 125°C		55			
				25°C		50		78	
$k_{SVR}$	Supply-voltage rejection ratio	$1.8\text{ V} \leq V_{CC+} \leq 5\text{ V}$ , $V_{IC} = 0.5\text{ V}$		25°C	75	100	dB		
				Full range		70			
$V_{ICR}$	Common-mode input voltage range	CMRR $\geq 50\text{ dB}$		25°C	$V_{CC-} - 0.2$	-0.2 to 5.3	$V_{CC+} + 0.2$	V	
				-40°C to 85°C		$V_{CC-}$			$V_{CC+}$
				-40°C to 125°C		$V_{CC-} + 0.3$			$V_{CC+} - 0.3$
$A_V$	Large-signal voltage gain	LMV981	$R_L = 600\ \Omega$ to 2.5 V, $V_O = 0.2\text{ V}$ to 4.8 V	25°C	88	102	dB		
				Full range		87			
			$R_L = 2\text{ k}\Omega$ to 2.5 V, $V_O = 0.2\text{ V}$ to 4.8 V	25°C	94	113			
		Full range		93					
		LMV982	$R_L = 600\ \Omega$ to 2.5 V, $V_O = 0.2\text{ V}$ to 4.8 V	25°C	81	90			
				Full range		78			
$R_L = 2\text{ k}\Omega$ to 2.5 V, $V_O = 0.2\text{ V}$ to 4.8 V	25°C		85	100					
	Full range		82						

**LMV981 SINGLE, LMV982 DUAL  
1.8-V OPERATIONAL AMPLIFIERS  
WITH RAIL-TO-RAIL INPUT AND OUTPUT AND SHUTDOWN**

SLOS440D – AUGUST 2004 – REVISED FEBRUARY 2005

electrical characteristics at  $T_A = 25^\circ\text{C}$ ,  $V_{CC+} = 5\text{ V}$ ,  $V_{CC-} = 0\text{ V}$ ,  $V_{IC} = V_{CC+}/2$ ,  $V_O = V_{CC+}/2$ ,  $R_L > 1\text{ M}\Omega$ , and SHDN tied to  $V_{CC+}$  (unless otherwise noted) (continued)

PARAMETER		TEST CONDITIONS	$T_A$	MIN	TYP	MAX	UNIT	
$V_O$	Output swing	$R_L = 600\ \Omega$ to 2.5 V, $V_{ID} = \pm 100\text{ mV}$	High level	25°C	4.855	4.89	V	
				Full range	4.835			
			Low level	25°C		0.12		0.16
				Full range				0.18
		$R_L = 2\text{ k}\Omega$ to 2.5 V, $V_{ID} = \pm 100\text{ mV}$	High level	25°C	4.945	4.967		
				Full range	4.935			
			Low level	25°C		0.037		0.065
				Full range				0.075
$I_{OS}$	Output short-circuit current	LMV981: $V_O = 0\text{ V}$ , $V_{ID} = 100\text{ mV}$	Sourcing	25°C	80	100	mA	
				Full range	68			
		$V_O = 5\text{ V}$ , $V_{ID} = -100\text{ mV}$	Sinking	25°C	58	65		
				Full range	45			
$T_{on}$	Turn-on time from shutdown		25°C		8.4	$\mu\text{s}$		
$V_{SHDN}$	Turn-on voltage to enable part		25°C		4.2	V		
	Turn-off voltage				0.8			
GBW	Gain bandwidth product		25°C		1.5	MHz		
SR	Slew rate	See Note 6	25°C		0.42	V/ $\mu\text{s}$		
$\Phi_m$	Phase margin		25°C		71	deg		
	Gain margin				8			
$V_n$	Equivalent input noise voltage	$f = 1\text{ kHz}$ , $V_{IC} = 1\text{ V}$	25°C		50	nV/ $\sqrt{\text{Hz}}$		
$I_n$	Equivalent input noise current	$f = 1\text{ kHz}$	25°C		0.07	pA/ $\sqrt{\text{Hz}}$		
THD	Total harmonic distortion	$f = 1\text{ kHz}$ , $A_V = 1$ , $R_L = 600\ \Omega$ , $V_{ID} = 1\text{ V}_{PP}$	25°C		0.022	%		
	Amp-to-amp isolation	See Note 7			123			

- NOTES: 6. Number specified is the slower of the positive and negative slew rates.  
7. Input referred,  $V_{CC+} = 5\text{ V}$  and  $R_L = 100\text{ k}\Omega$  connected to 2.5 V. Each amp is excited in turn with a 1-kHz signal to produce  $V_O = 3\text{ V}_{PP}$ .

**LMV981 SINGLE, LMV982 DUAL  
1.8-V OPERATIONAL AMPLIFIERS  
WITH RAIL-TO-RAIL INPUT AND OUTPUT AND SHUTDOWN**

SLOS440D – AUGUST 2004 – REVISED FEBRUARY 2005

**TYPICAL PERFORMANCE CHARACTERISTICS**  
Unless Otherwise Specified,  $V_{CC+} = 5\text{ V}$ , Single Supply,  $T_A = 25^\circ\text{C}$

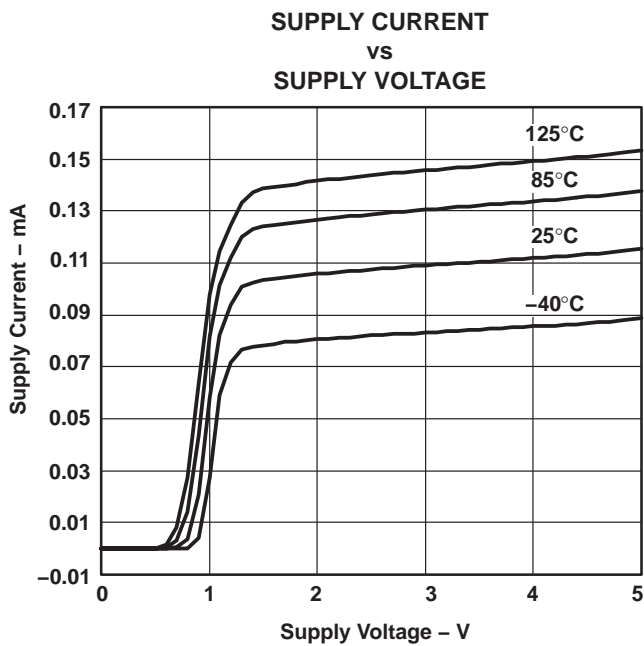


Figure 1

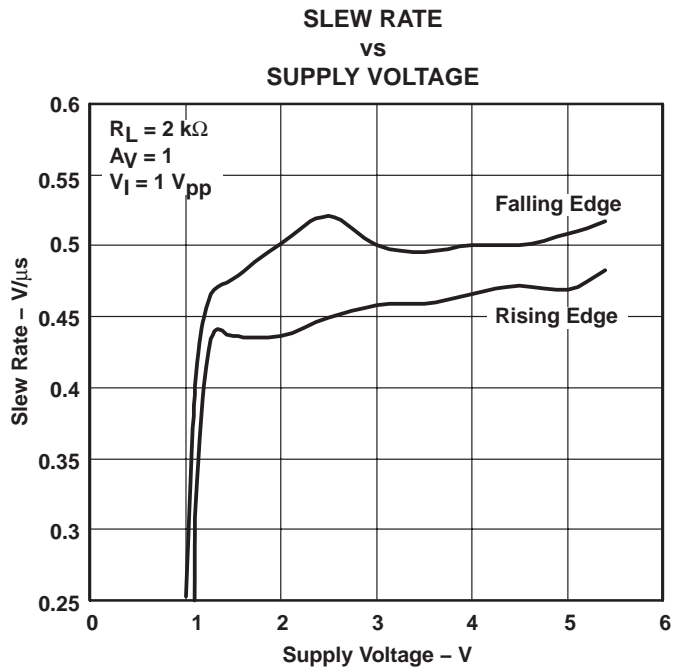


Figure 2

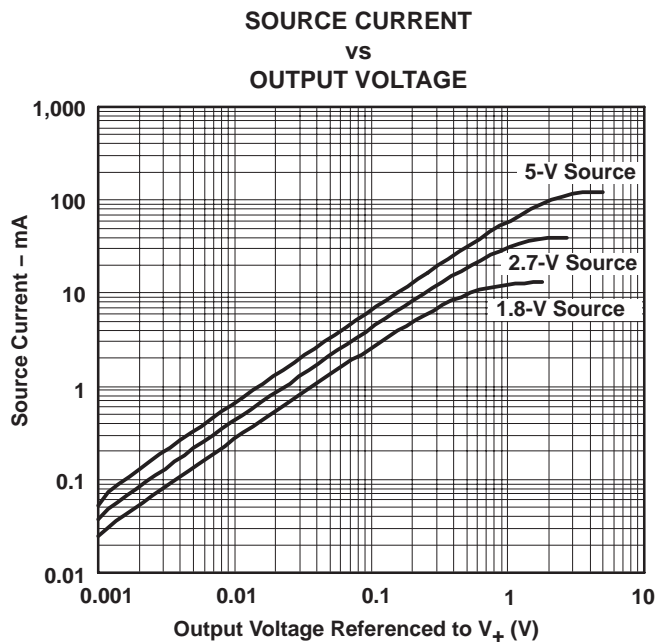


Figure 3

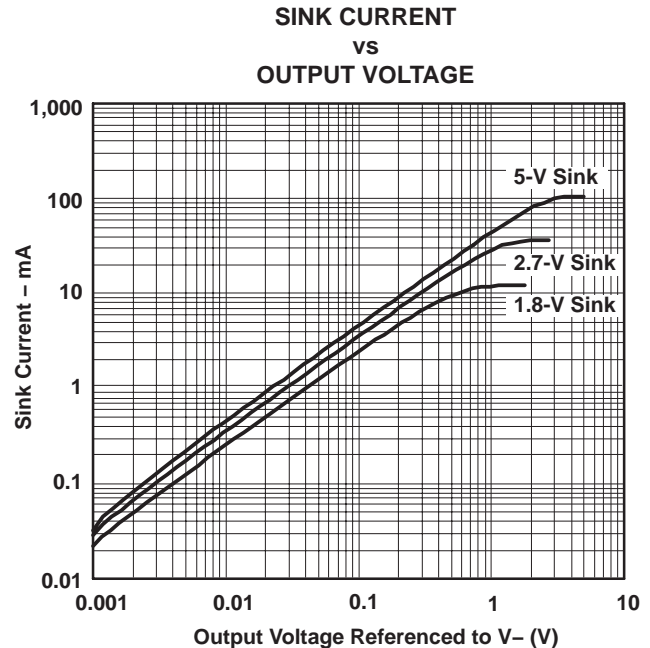


Figure 4

# LMV981 SINGLE, LMV982 DUAL 1.8-V OPERATIONAL AMPLIFIERS WITH RAIL-TO-RAIL INPUT AND OUTPUT AND SHUTDOWN

SLOS440D – AUGUST 2004 – REVISED FEBRUARY 2005

## TYPICAL PERFORMANCE CHARACTERISTICS Unless Otherwise Specified, $V_{CC+} = 5\text{ V}$ , Single Supply, $T_A = 25^\circ\text{C}$

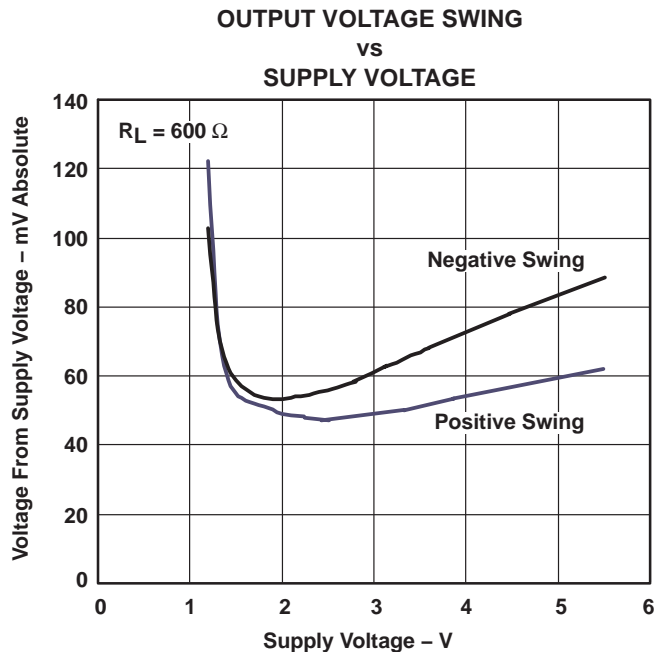


Figure 5

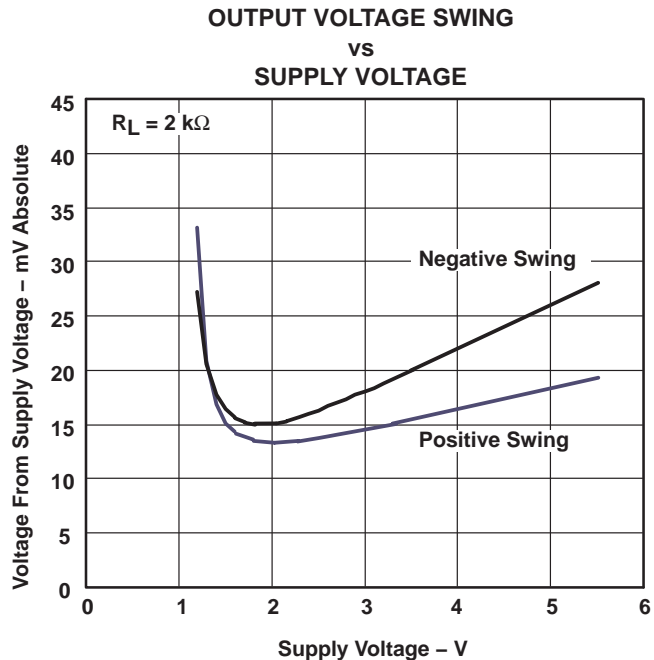


Figure 6

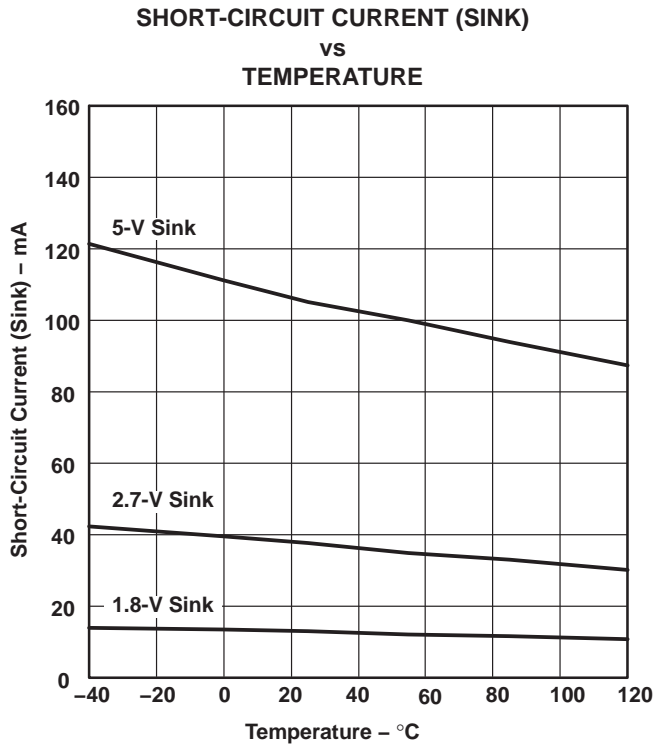


Figure 7

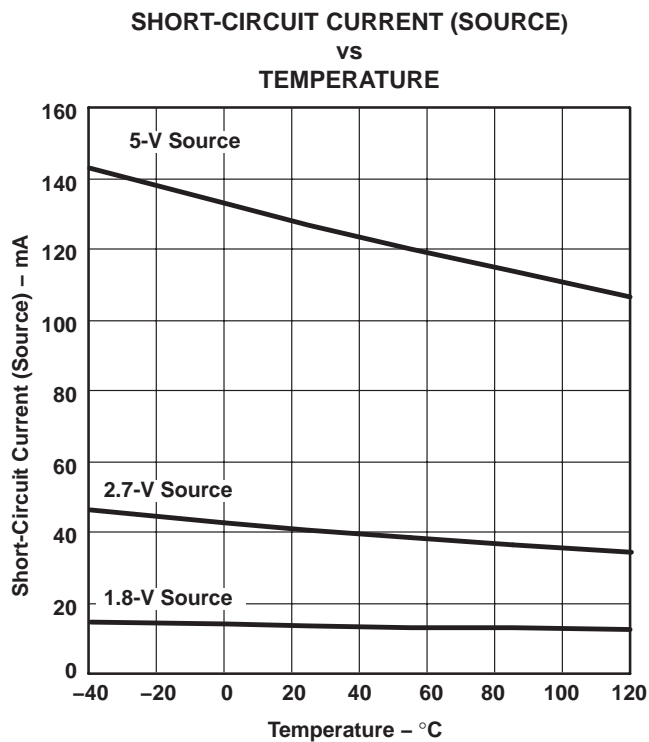


Figure 8

**LMV981 SINGLE, LMV982 DUAL  
1.8-V OPERATIONAL AMPLIFIERS  
WITH RAIL-TO-RAIL INPUT AND OUTPUT AND SHUTDOWN**

SLOS440D – AUGUST 2004 – REVISED FEBRUARY 2005

**TYPICAL PERFORMANCE CHARACTERISTICS**  
Unless Otherwise Specified,  $V_{CC+} = 5\text{ V}$ , Single Supply,  $T_A = 25^\circ\text{C}$

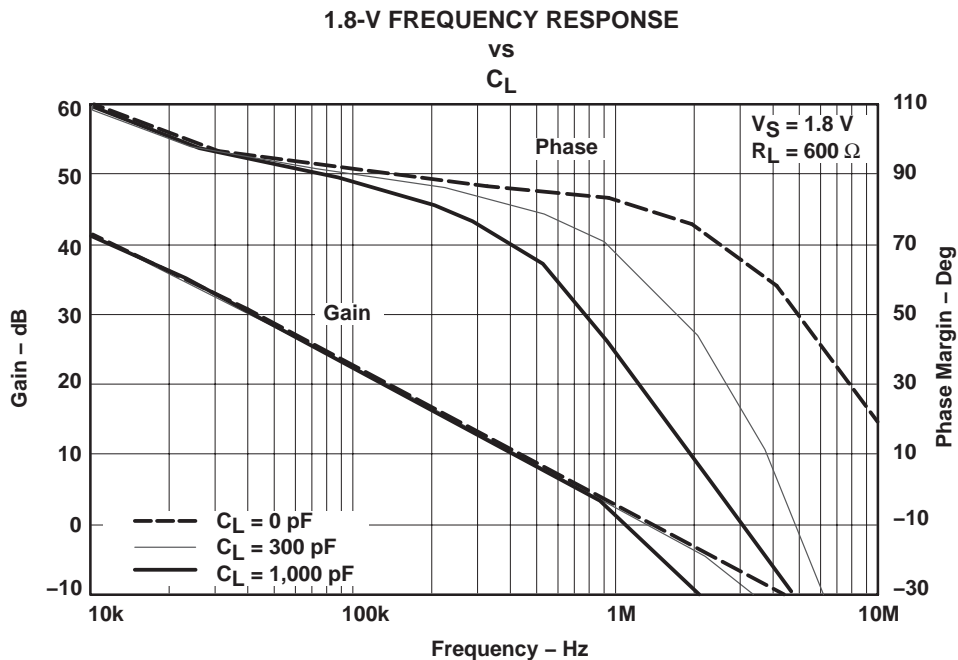


Figure 9

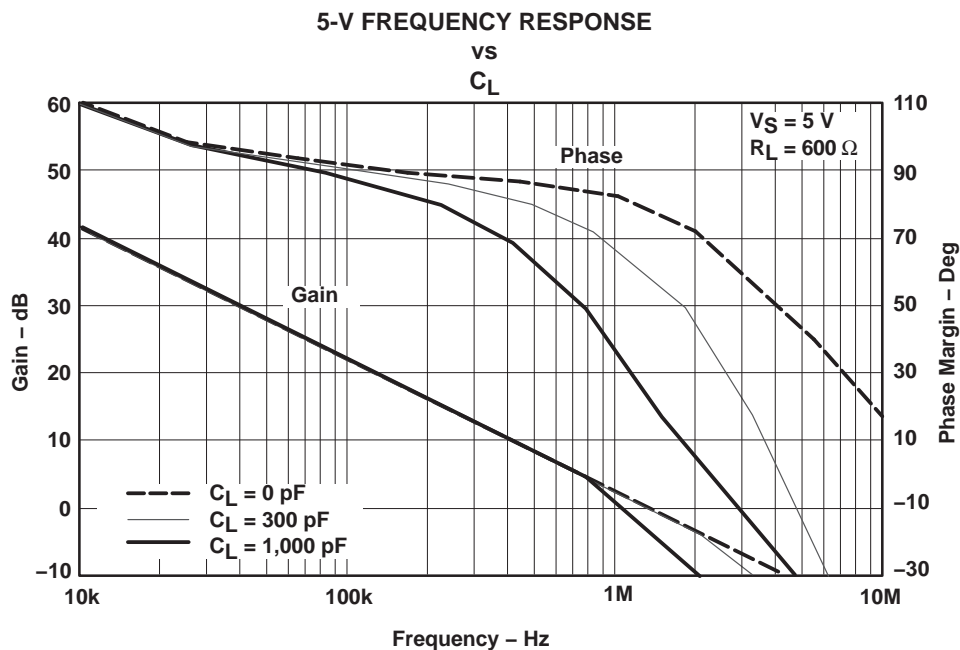


Figure 10



# LMV981 SINGLE, LMV982 DUAL 1.8-V OPERATIONAL AMPLIFIERS WITH RAIL-TO-RAIL INPUT AND OUTPUT AND SHUTDOWN

SLOS440D – AUGUST 2004 – REVISED FEBRUARY 2005

## TYPICAL PERFORMANCE CHARACTERISTICS Unless Otherwise Specified, $V_{CC+} = 5\text{ V}$ , Single Supply, $T_A = 25^\circ\text{C}$

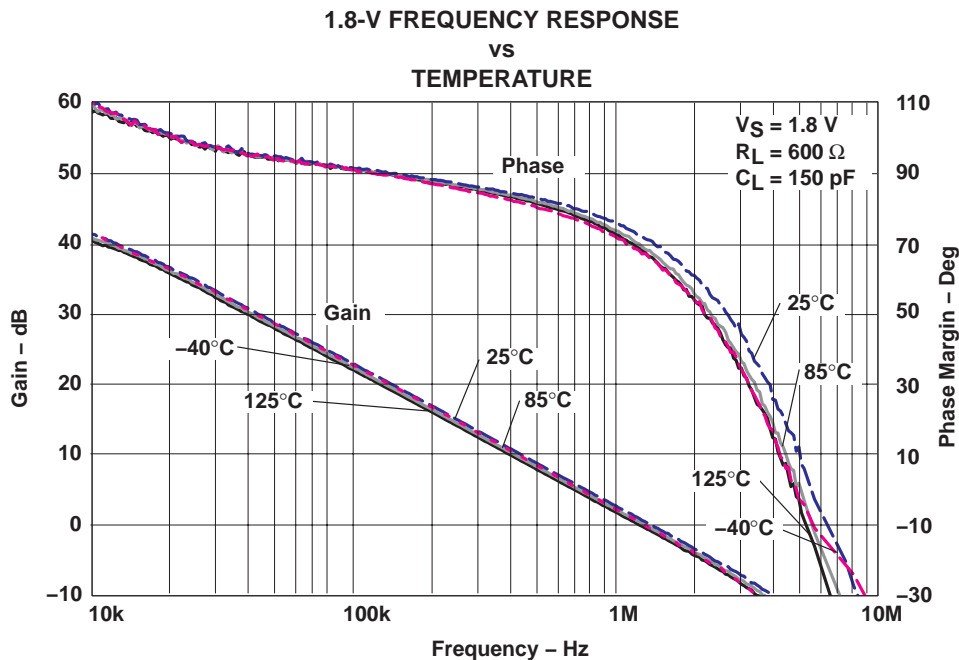


Figure 11

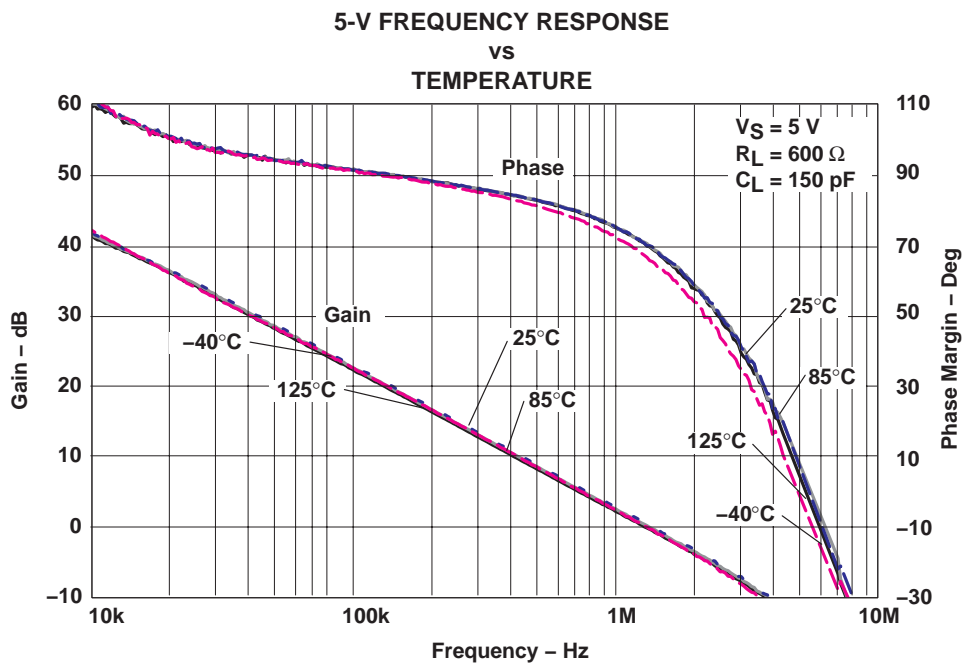


Figure 12

**LMV981 SINGLE, LMV982 DUAL  
1.8-V OPERATIONAL AMPLIFIERS  
WITH RAIL-TO-RAIL INPUT AND OUTPUT AND SHUTDOWN**

SLOS440D – AUGUST 2004 – REVISED FEBRUARY 2005

**TYPICAL PERFORMANCE CHARACTERISTICS**  
Unless Otherwise Specified,  $V_{CC+} = 5\text{ V}$ , Single Supply,  $T_A = 25^\circ\text{C}$

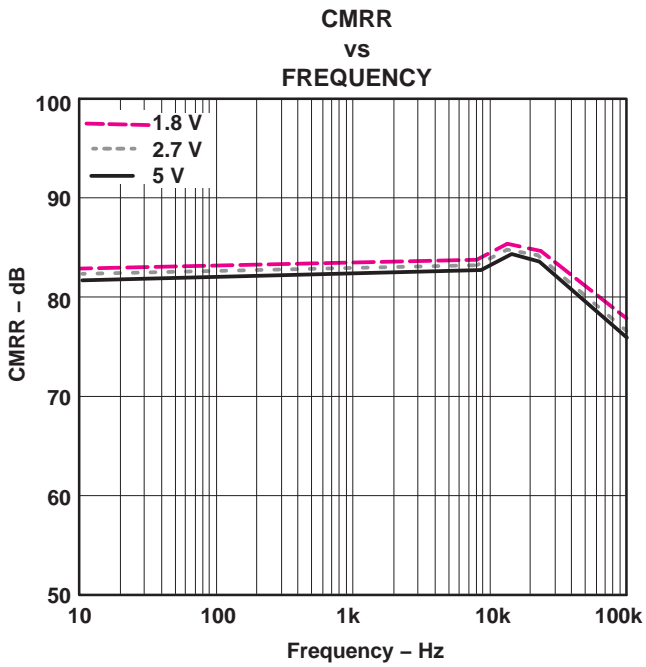


Figure 13

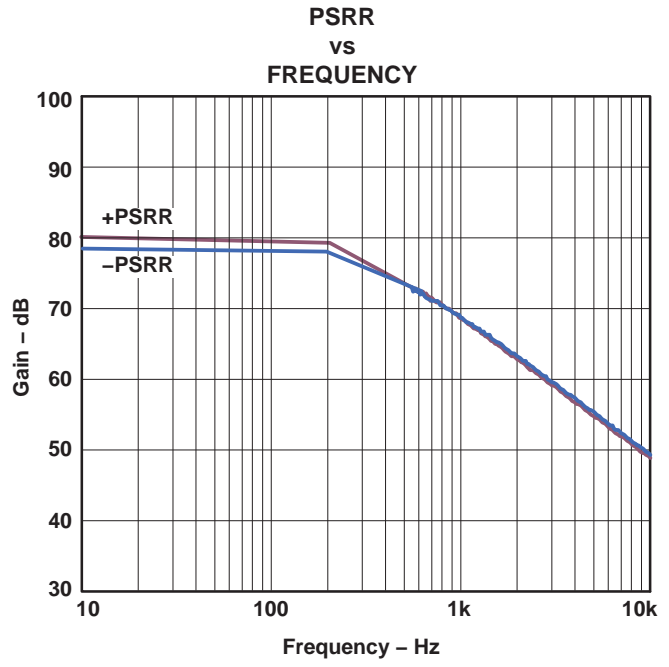


Figure 14

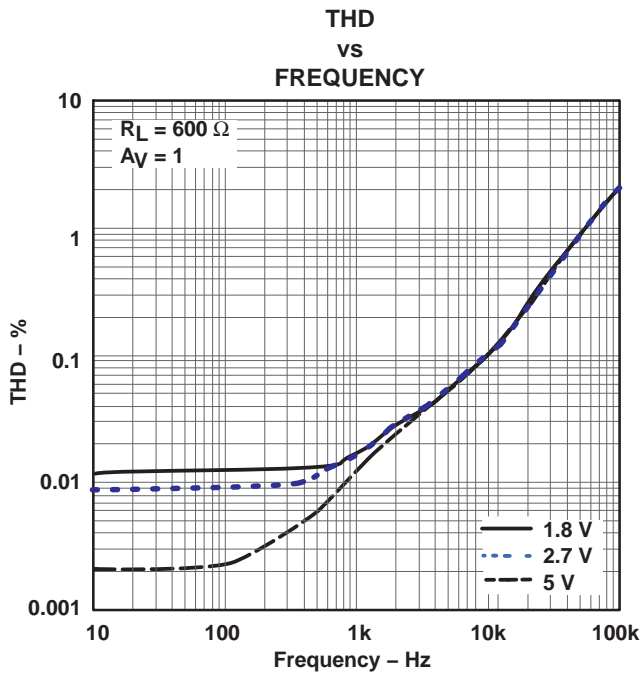


Figure 15

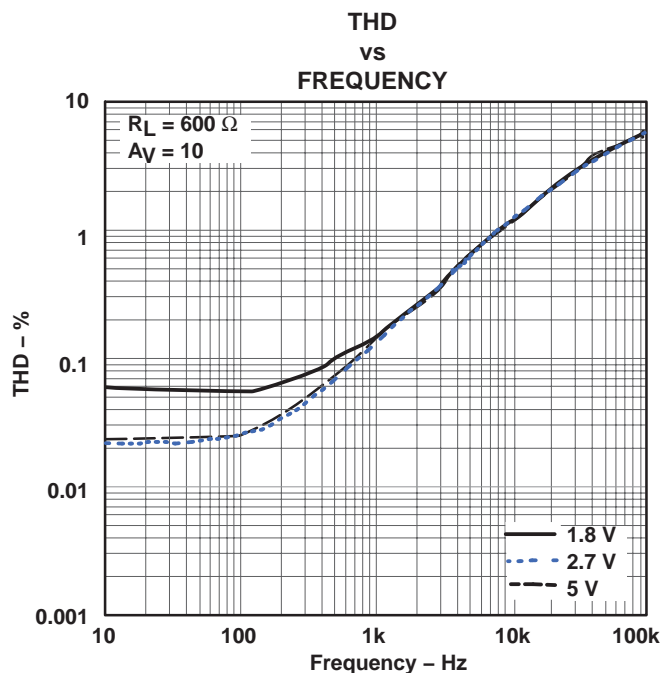


Figure 16



# LMV981 SINGLE, LMV982 DUAL 1.8-V OPERATIONAL AMPLIFIERS WITH RAIL-TO-RAIL INPUT AND OUTPUT AND SHUTDOWN

SLOS440D – AUGUST 2004 – REVISED FEBRUARY 2005

## TYPICAL PERFORMANCE CHARACTERISTICS Unless Otherwise Specified, $V_{CC+} = 5\text{ V}$ , Single Supply, $T_A = 25^\circ\text{C}$

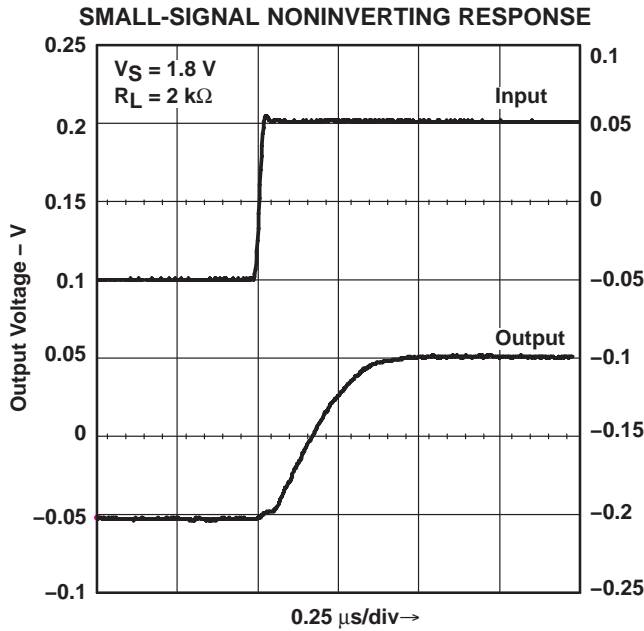


Figure 17

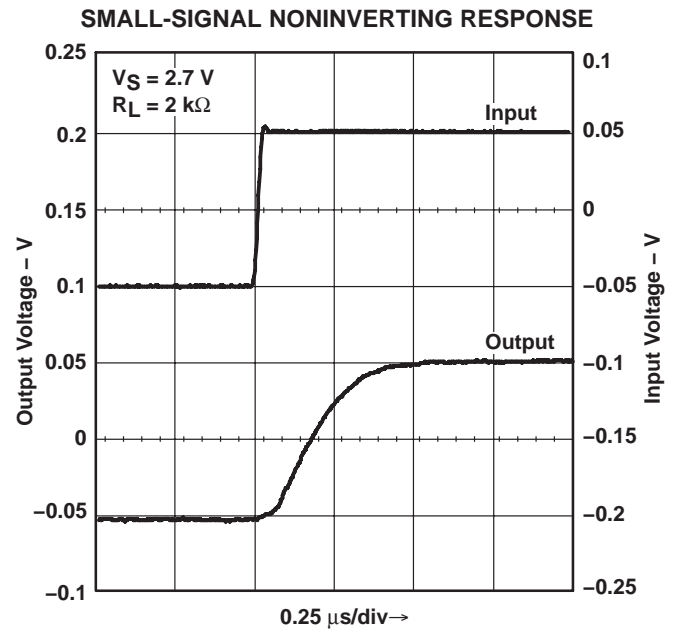


Figure 18

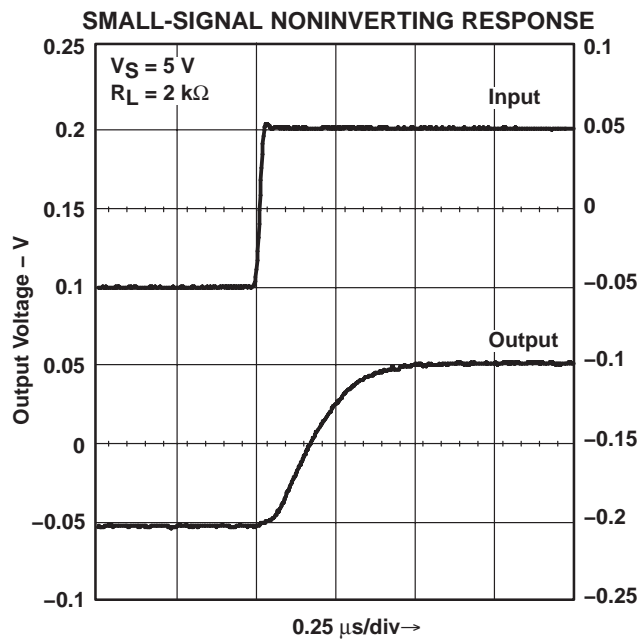


Figure 19

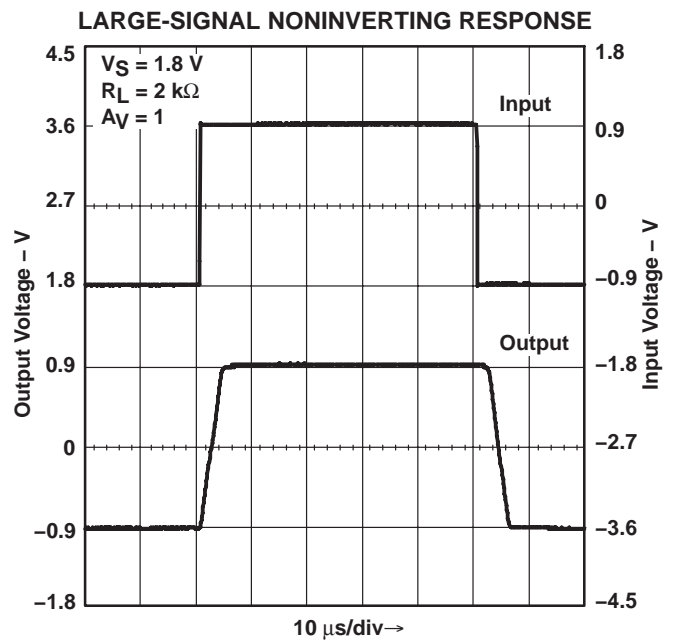
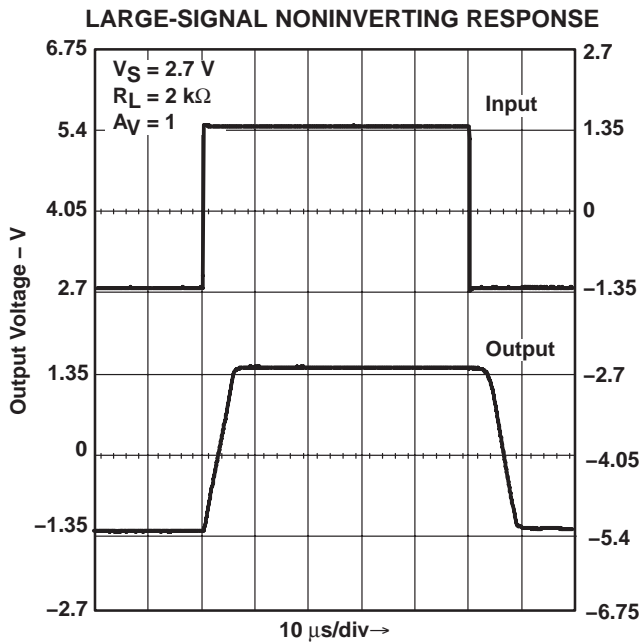


Figure 20

**LMV981 SINGLE, LMV982 DUAL  
1.8-V OPERATIONAL AMPLIFIERS  
WITH RAIL-TO-RAIL INPUT AND OUTPUT AND SHUTDOWN**

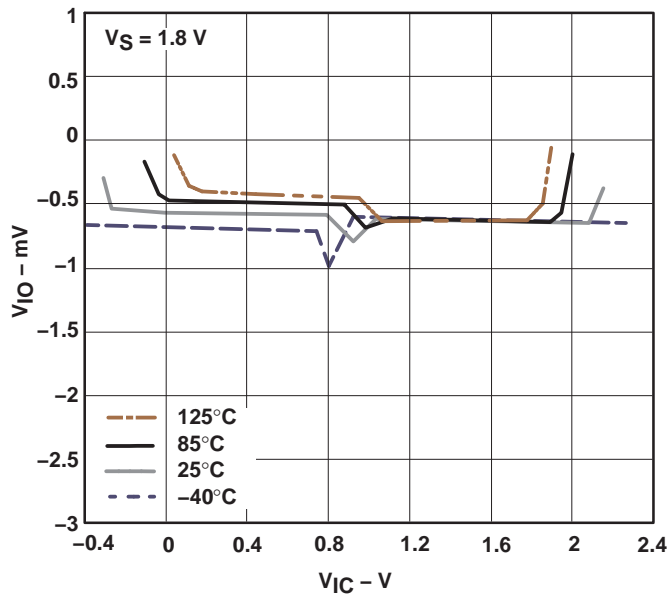
SLOS440D – AUGUST 2004 – REVISED FEBRUARY 2005

**TYPICAL PERFORMANCE CHARACTERISTICS**  
Unless Otherwise Specified,  $V_{CC+} = 5\text{ V}$ , Single Supply,  $T_A = 25^\circ\text{C}$

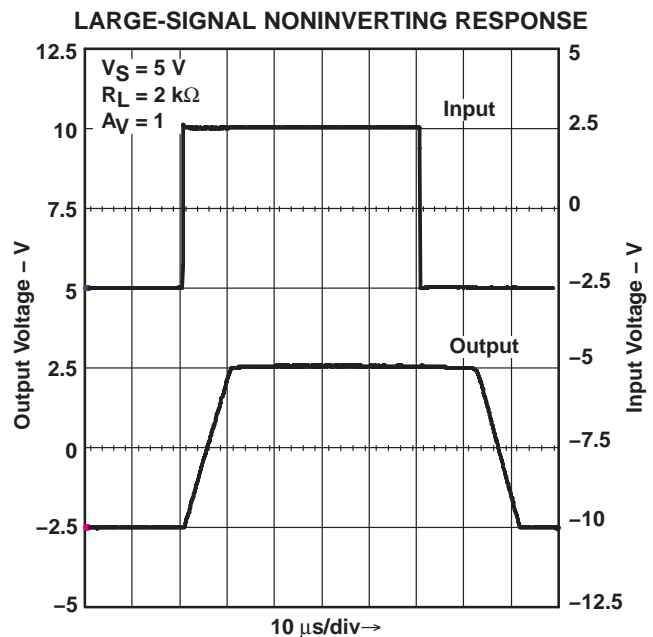


**Figure 21**

**OFFSET VOLTAGE  
vs  
COMMON-MODE RANGE**

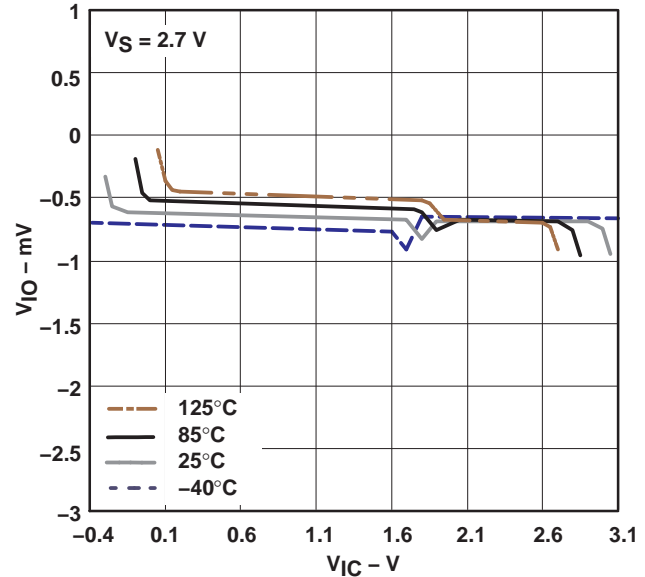


**Figure 23**



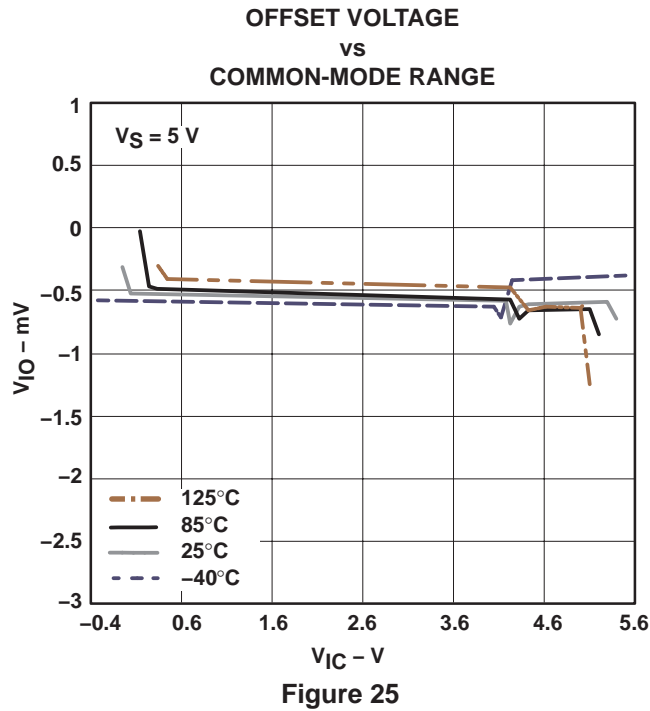
**Figure 22**

**OFFSET VOLTAGE  
vs  
COMMON-MODE RANGE**



**Figure 24**

TYPICAL PERFORMANCE CHARACTERISTICS  
Unless Otherwise Specified,  $V_{CC+} = 5\text{ V}$ , Single Supply,  $T_A = 25^\circ\text{C}$



**PACKAGING INFORMATION**

Orderable Device	Status <sup>(1)</sup>	Package Type	Package Drawing	Pins	Package Qty	Eco Plan <sup>(2)</sup>	Lead/Ball Finish	MSL Peak Temp <sup>(3)</sup>
LMV981IDBVR	ACTIVE	SOT-23	DBV	6	3000	Pb-Free (RoHS)	CU NIPDAU	Level-1-260C-UNLIM
LMV981IDCKR	ACTIVE	SC70	DCK	6	3000	Pb-Free (RoHS)	CU NIPDAU	Level-1-260C-UNLIM

<sup>(1)</sup> The marketing status values are defined as follows:

**ACTIVE:** Product device recommended for new designs.

**LIFEBUY:** TI has announced that the device will be discontinued, and a lifetime-buy period is in effect.

**NRND:** Not recommended for new designs. Device is in production to support existing customers, but TI does not recommend using this part in a new design.

**PREVIEW:** Device has been announced but is not in production. Samples may or may not be available.

**OBsolete:** TI has discontinued the production of the device.

<sup>(2)</sup> Eco Plan - May not be currently available - please check <http://www.ti.com/productcontent> for the latest availability information and additional product content details.

**None:** Not yet available Lead (Pb-Free).

**Pb-Free (RoHS):** TI's terms "Lead-Free" or "Pb-Free" mean semiconductor products that are compatible with the current RoHS requirements for all 6 substances, including the requirement that lead not exceed 0.1% by weight in homogeneous materials. Where designed to be soldered at high temperatures, TI Pb-Free products are suitable for use in specified lead-free processes.

**Green (RoHS & no Sb/Br):** TI defines "Green" to mean "Pb-Free" and in addition, uses package materials that do not contain halogens, including bromine (Br) or antimony (Sb) above 0.1% of total product weight.

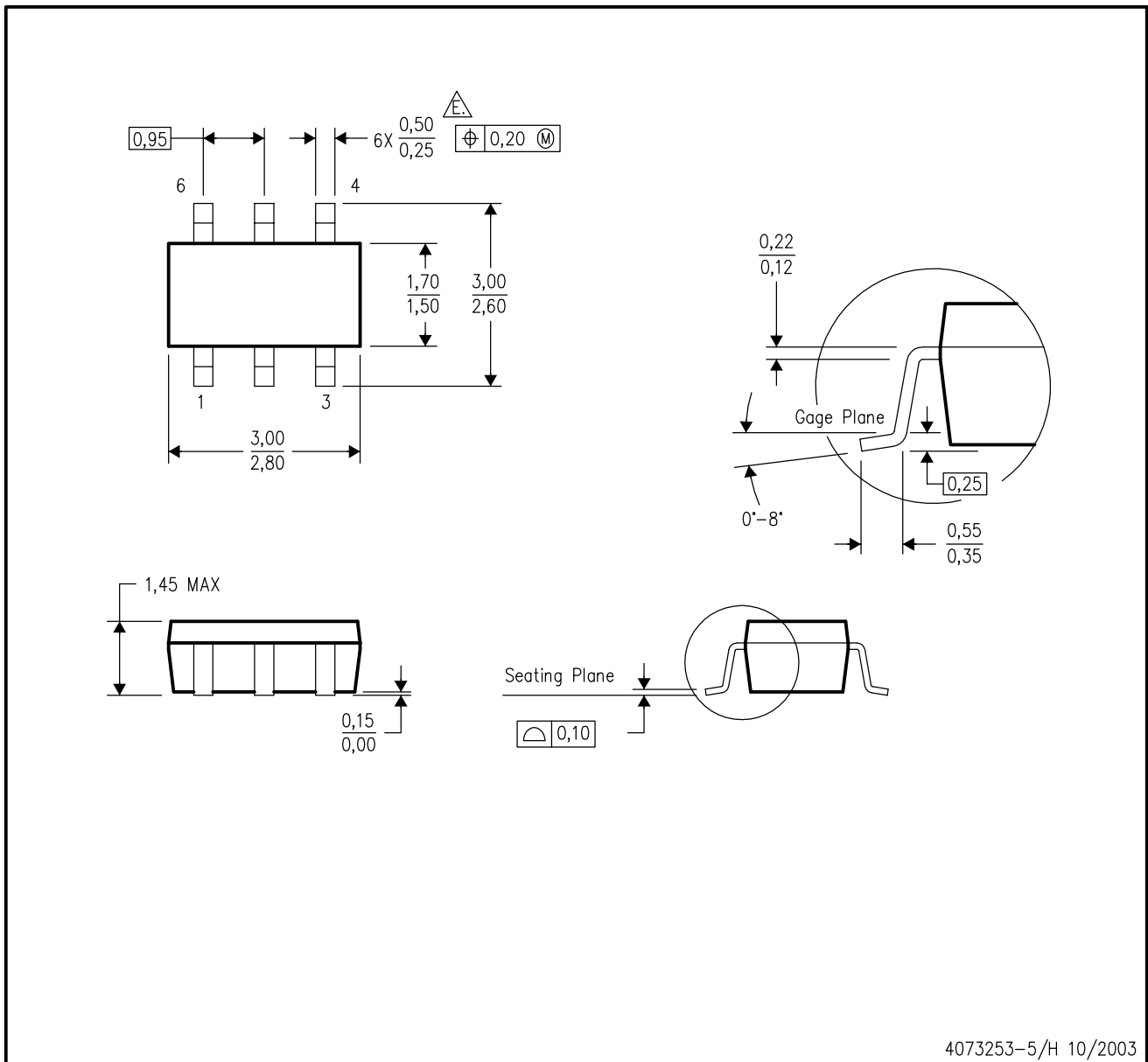
<sup>(3)</sup> MSL, Peak Temp. -- The Moisture Sensitivity Level rating according to the JEDEC industry standard classifications, and peak solder temperature.

**Important Information and Disclaimer:** The information provided on this page represents TI's knowledge and belief as of the date that it is provided. TI bases its knowledge and belief on information provided by third parties, and makes no representation or warranty as to the accuracy of such information. Efforts are underway to better integrate information from third parties. TI has taken and continues to take reasonable steps to provide representative and accurate information but may not have conducted destructive testing or chemical analysis on incoming materials and chemicals. TI and TI suppliers consider certain information to be proprietary, and thus CAS numbers and other limited information may not be available for release.

In no event shall TI's liability arising out of such information exceed the total purchase price of the TI part(s) at issue in this document sold by TI to Customer on an annual basis.

DBV (R-PDSO-G6)

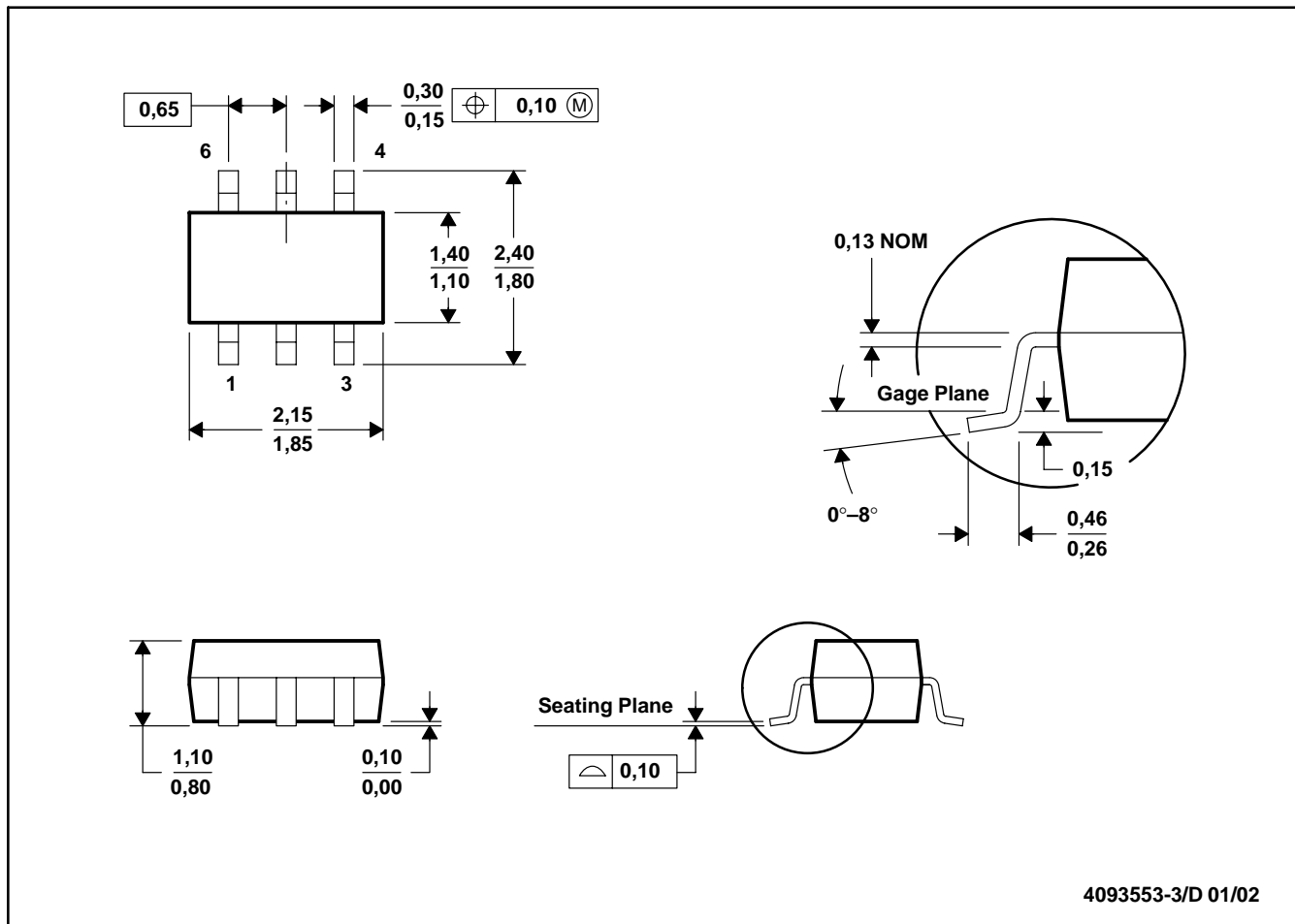
PLASTIC SMALL-OUTLINE PACKAGE



- NOTES:
- A. All linear dimensions are in millimeters.
  - B. This drawing is subject to change without notice.
  - C. Body dimensions do not include mold flash or protrusion.
  - D. Leads 1,2,3 may be wider than leads 4,5,6 for package orientation.
  - $\Delta$  Falls within JEDEC MO-178 Variation AB, except minimum lead width.

DCK (R-PDSO-G6)

PLASTIC SMALL-OUTLINE PACKAGE



4093553-3/D 01/02

- NOTES: A. All linear dimensions are in millimeters.  
 B. This drawing is subject to change without notice.  
 C. Body dimensions do not include mold flash or protrusion.  
 D. Falls within JEDEC MO-203

## IMPORTANT NOTICE

Texas Instruments Incorporated and its subsidiaries (TI) reserve the right to make corrections, modifications, enhancements, improvements, and other changes to its products and services at any time and to discontinue any product or service without notice. Customers should obtain the latest relevant information before placing orders and should verify that such information is current and complete. All products are sold subject to TI's terms and conditions of sale supplied at the time of order acknowledgment.

TI warrants performance of its hardware products to the specifications applicable at the time of sale in accordance with TI's standard warranty. Testing and other quality control techniques are used to the extent TI deems necessary to support this warranty. Except where mandated by government requirements, testing of all parameters of each product is not necessarily performed.

TI assumes no liability for applications assistance or customer product design. Customers are responsible for their products and applications using TI components. To minimize the risks associated with customer products and applications, customers should provide adequate design and operating safeguards.

TI does not warrant or represent that any license, either express or implied, is granted under any TI patent right, copyright, mask work right, or other TI intellectual property right relating to any combination, machine, or process in which TI products or services are used. Information published by TI regarding third-party products or services does not constitute a license from TI to use such products or services or a warranty or endorsement thereof. Use of such information may require a license from a third party under the patents or other intellectual property of the third party, or a license from TI under the patents or other intellectual property of TI.

Reproduction of information in TI data books or data sheets is permissible only if reproduction is without alteration and is accompanied by all associated warranties, conditions, limitations, and notices. Reproduction of this information with alteration is an unfair and deceptive business practice. TI is not responsible or liable for such altered documentation.

Resale of TI products or services with statements different from or beyond the parameters stated by TI for that product or service voids all express and any implied warranties for the associated TI product or service and is an unfair and deceptive business practice. TI is not responsible or liable for any such statements.

Following are URLs where you can obtain information on other Texas Instruments products and application solutions:

<b>Products</b>		<b>Applications</b>	
Amplifiers	<a href="http://amplifier.ti.com">amplifier.ti.com</a>	Audio	<a href="http://www.ti.com/audio">www.ti.com/audio</a>
Data Converters	<a href="http://dataconverter.ti.com">dataconverter.ti.com</a>	Automotive	<a href="http://www.ti.com/automotive">www.ti.com/automotive</a>
DSP	<a href="http://dsp.ti.com">dsp.ti.com</a>	Broadband	<a href="http://www.ti.com/broadband">www.ti.com/broadband</a>
Interface	<a href="http://interface.ti.com">interface.ti.com</a>	Digital Control	<a href="http://www.ti.com/digitalcontrol">www.ti.com/digitalcontrol</a>
Logic	<a href="http://logic.ti.com">logic.ti.com</a>	Military	<a href="http://www.ti.com/military">www.ti.com/military</a>
Power Mgmt	<a href="http://power.ti.com">power.ti.com</a>	Optical Networking	<a href="http://www.ti.com/opticalnetwork">www.ti.com/opticalnetwork</a>
Microcontrollers	<a href="http://microcontroller.ti.com">microcontroller.ti.com</a>	Security	<a href="http://www.ti.com/security">www.ti.com/security</a>
		Telephony	<a href="http://www.ti.com/telephony">www.ti.com/telephony</a>
		Video & Imaging	<a href="http://www.ti.com/video">www.ti.com/video</a>
		Wireless	<a href="http://www.ti.com/wireless">www.ti.com/wireless</a>

Mailing Address: Texas Instruments  
Post Office Box 655303 Dallas, Texas 75265