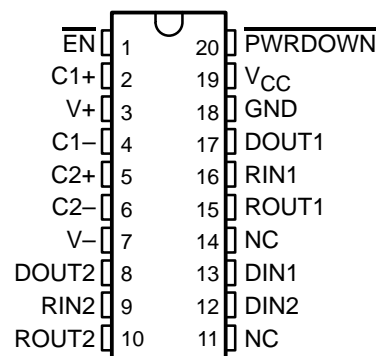

- Meets or Exceeds the Requirements of TIA/EIA-232-F and ITU v.28 Standards
- Operates With 3-V to 5.5-V  $V_{CC}$  Supply
- Operates up to 250 kbit/s
- Two Drivers and Two Receivers
- Low Standby Current . . . 1  $\mu$ A Typical
- External Capacitors . . .  $4 \times 0.1 \mu$ F
- Accepts 5-V Logic Input With 3.3-V Supply
- Designed to Be Interchangeable With Maxim MAX3222
- RS-232 Bus-Pin ESD Protection Exceeds  $\pm 15$  kV Using Human-Body Model (HBM)
- Applications
  - Battery-Powered Systems, PDAs, Notebooks, Laptops, Palmtop PCs, and Hand-Held Equipment

DB, DW, OR PW PACKAGE  
(TOP VIEW)

NC – No internal connection

### description/ordering information

The MAX3222 consists of two line drivers, two line receivers, and a dual charge-pump circuit with  $\pm 15$ -kV ESD protection pin to pin (serial-port connection pins, including GND). The device meets the requirements of TIA/EIA-232-F and provides the electrical interface between an asynchronous communication controller and the serial-port connector. The charge pump and four small external capacitors allow operation from a single 3-V to 5.5-V supply. The device operates at data signaling rates up to 250 kbit/s and a maximum of 30-V/ $\mu$ s driver output slew rate.

The MAX3222 can be placed in the power-down mode by setting  $\overline{\text{PWRDOWN}}$  low, which draws only 1  $\mu$ A from the power supply. When the device is powered down, the receivers remain active while the drivers are placed in the high-impedance state. Also, during power down, the onboard charge pump is disabled;  $V+$  is lowered to  $V_{CC}$ , and  $V-$  is raised toward GND. Receiver outputs also can be placed in the high-impedance state by setting EN high.

### ORDERING INFORMATION

$T_A$	PACKAGE <sup>†</sup>		ORDERABLE PART NUMBER	TOP-SIDE MARKING
–0°C to 70°C	SOIC (DW)	Tube	MAX3222CDW	MAX3222C
		Tape and reel	MAX3222CDWR	
	SSOP (DB)	Tape and reel	MAX3222CDBR	MA3222C
	TSSOP (PW)	Tape and reel	MAX3222CPWR	MA3222C
–40°C to 85°C	SOIC (DW)	Tube	MAX3222IDW	MAX3222I
		Tape and reel	MAX3222IDWR	
	SSOP (DB)	Tape and reel	MAX3222IDBR	MB3222I
	TSSOP (PW)	Tape and reel	MAX3222IPWR	MB3222I

<sup>†</sup> Package drawings, standard packing quantities, thermal data, symbolization, and PCB design guidelines are available at [www.ti.com/sc/package](http://www.ti.com/sc/package).



Please be aware that an important notice concerning availability, standard warranty, and use in critical applications of Texas Instruments semiconductor products and disclaimers thereto appears at the end of this data sheet.

PRODUCTION DATA information is current as of publication date. Products conform to specifications per the terms of Texas Instruments standard warranty. Production processing does not necessarily include testing of all parameters.

 **TEXAS  
INSTRUMENTS**

POST OFFICE BOX 655303 • DALLAS, TEXAS 75265

Copyright © 2002, Texas Instruments Incorporated

# MAX3222

## 3-V TO 5.5-V MULTICHANNEL RS-232 LINE DRIVER/RECEIVER

SLLS408C – JANUARY 2000 – REVISED AUGUST 2002

### Function Tables

#### EACH DRIVER

INPUTS		OUTPUT DOUT
DIN	PWRDOWN	
X	L	Z
L	H	H
H	H	L

H = high level, L = low level, X = irrelevant,  
Z = high impedance

#### EACH RECEIVER

INPUTS		OUTPUT ROUT
RIN	EN	
L	L	H
H	L	L
X	H	Z
Open	L	H

H = high level, L = low level, X = irrelevant,  
Z = high impedance (off), Open = input  
disconnected or connected driver off

### logic diagram (positive logic)

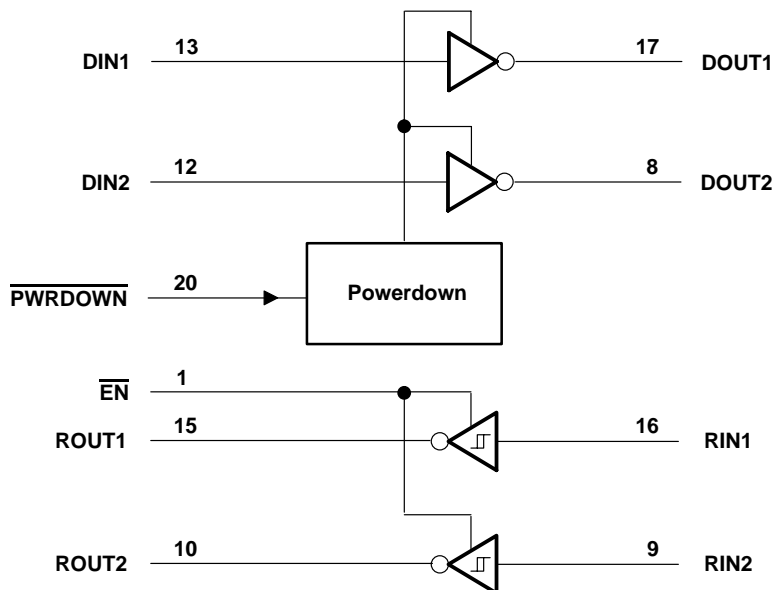

**absolute maximum ratings over operating free-air temperature range (unless otherwise noted)†**

Supply voltage range, $V_{CC}$ (see Note 1)	–0.3 V to 6 V
Positive output supply voltage range, $V+$ (see Note 1)	–0.3 V to 7 V
Negative output supply voltage range, $V-$ (see Note 1)	0.3 V to –7 V
Supply voltage difference, $V+ - V-$ (see Note 1)	13 V
Input voltage range, $V_I$ : Drivers, $\overline{EN}$ , $\overline{PWRDOWN}$	–0.3 V to 6 V
Receivers	–25 V to 25 V
Output voltage range, $V_O$ : Drivers	–13.2 V to 13.2 V
Receivers	–0.3 V to $V_{CC} + 0.3$ V
Package thermal impedance, $\theta_{JA}$ (see Note 2): DB package	70°C/W
DW package	58°C/W
PW package	83°C/W
Lead temperature 1,6 mm (1/16 inch) from case for 10 seconds	260°C
Storage temperature range, $T_{stg}$	–65°C to 150°C

† Stresses beyond those listed under “absolute maximum ratings” may cause permanent damage to the device. These are stress ratings only, and functional operation of the device at these or any other conditions beyond those indicated under “recommended operating conditions” is not implied. Exposure to absolute-maximum-rated conditions for extended periods may affect device reliability.

NOTES: 1. All voltages are with respect to network GND.

2. The package thermal impedance is calculated in accordance with JESD 51-7.

**recommended operating conditions (see Note 3 and Figure 5)**

		MIN	NOM	MAX	UNIT
Supply voltage	$V_{CC} = 3.3$ V	3	3.3	3.6	V
	$V_{CC} = 5$ V	4.5	5	5.5	
$V_{IH}$ Driver and control high-level input voltage	DIN, $\overline{EN}$ , $\overline{PWRDOWN}$	$V_{CC} = 3.3$ V		2	V
		$V_{CC} = 5$ V		2.4	
$V_{IL}$ Driver and control low-level input voltage	DIN, $\overline{EN}$ , $\overline{PWRDOWN}$			0.8	V
$V_I$ Driver and control input voltage	DIN, $\overline{EN}$ , $\overline{PWRDOWN}$	0		5.5	V
$V_I$ Receiver input voltage		–25		25	V
$T_A$ Operating free-air temperature	MAX3222C	0		70	°C
	MAX3222I	–40		85	

NOTE 3: Test conditions are C1–C4 = 0.1  $\mu$ F at  $V_{CC} = 3.3$  V  $\pm$  0.3 V; C1 = 0.047  $\mu$ F, C2–C4 = 0.33  $\mu$ F at  $V_{CC} = 5$  V  $\pm$  0.5 V.

**electrical characteristics over recommended ranges of supply voltage and operating free-air temperature (unless otherwise noted) (see Note 3 and Figure 5)**

PARAMETER		TEST CONDITIONS	MIN	TYP‡	MAX	UNIT
$I_l$	Input leakage current ( $\overline{EN}$ , $\overline{PWRDOWN}$ )			$\pm 0.01$	$\pm 1$	$\mu$ A
$I_{CC}$	Supply current	No load, $\overline{PWRDOWN}$ at $V_{CC}$		0.3	1	mA
	Supply current (powered off)	No load, $\overline{PWRDOWN}$ at GND		1	10	$\mu$ A

‡ All typical values are at  $V_{CC} = 3.3$  V or  $V_{CC} = 5$  V, and  $T_A = 25^\circ$ C.

NOTE 3: Test conditions are C1–C4 = 0.1  $\mu$ F at  $V_{CC} = 3.3$  V  $\pm$  0.3 V; C1 = 0.047  $\mu$ F, C2–C4 = 0.33  $\mu$ F at  $V_{CC} = 5$  V  $\pm$  0.5 V.

# MAX3222

## 3-V TO 5.5-V MULTICHANNEL RS-232 LINE DRIVER/RECEIVER

SLLS408C – JANUARY 2000 – REVISED AUGUST 2002

### DRIVER SECTION

**electrical characteristics over recommended ranges of supply voltage and operating free-air temperature (unless otherwise noted) (see Note 3 and Figure 5)**

PARAMETER	TEST CONDITIONS	MIN	TYP†	MAX	UNIT
V <sub>OH</sub> High-level output voltage	DOUT at R <sub>L</sub> = 3 kΩ to GND, DIN = GND	5	5.4		V
V <sub>OL</sub> Low-level output voltage	DOUT at R <sub>L</sub> = 3 kΩ to GND, DIN = V <sub>CC</sub>	-5	-5.4		V
I <sub>IH</sub> High-level input current	V <sub>I</sub> = V <sub>CC</sub>		±0.01	±1	μA
I <sub>IL</sub> Low-level input current	V <sub>I</sub> at GND		±0.01	±1	μA
I <sub>OS</sub> Short-circuit output current‡	V <sub>CC</sub> = 3.6 V, V <sub>O</sub> = 0 V		±35	±60	mA
	V <sub>CC</sub> = 5.5 V, V <sub>O</sub> = 0 V				
r <sub>o</sub> Output resistance	V <sub>CC</sub> , V <sub>+</sub> , and V <sub>-</sub> = 0 V, V <sub>O</sub> = ±2 V	300	10M		Ω
I <sub>off</sub> Output leakage current	PWRDOWN = GND, V <sub>O</sub> = ±12 V, V <sub>CC</sub> = 0 to 5.5 V			±25	mA

† All typical values are at V<sub>CC</sub> = 3.3 V or V<sub>CC</sub> = 5 V, and T<sub>A</sub> = 25°C.

‡ Short-circuit durations should be controlled to prevent exceeding the device absolute power-dissipation ratings, and not more than one output should be shorted at a time.

NOTE 3: Test conditions are C1–C4 = 0.1 μF at V<sub>CC</sub> = 3.3 V ± 0.3 V; C1 = 0.047 μF, C2–C4 = 0.33 μF at V<sub>CC</sub> = 5 V ± 0.5 V.

**switching characteristics over recommended ranges of supply voltage and operating free-air temperature (unless otherwise noted) (see Note 3 and Figure 5)**

PARAMETER	TEST CONDITIONS	MIN	TYP†	MAX	UNIT
Maximum data rate	C <sub>L</sub> = 1000 pF, R <sub>L</sub> = 3 kΩ, One DOUT switching, See Figure 1	150	250		kbit/s
t <sub>sk(p)</sub> Pulse skew§	C <sub>L</sub> = 150 pF to 2500 pF, R <sub>L</sub> = 3 kΩ to 7 kΩ, See Figure 2		300		ns
SR(tr) Slew rate, transition region (See Figure 1)	R <sub>L</sub> = 3 kΩ to 7 kΩ, V <sub>CC</sub> = 3.3 V	C <sub>L</sub> = 150 pF to 1000 pF	6	30	V/μs
		C <sub>L</sub> = 150 pF to 2500 pF	4	30	

† All typical values are at V<sub>CC</sub> = 3.3 V or V<sub>CC</sub> = 5 V, and T<sub>A</sub> = 25°C.

§ Pulse skew is defined as |t<sub>pLH</sub> - t<sub>pHL</sub>| of each channel of the same device.

NOTE 3: Test conditions are C1–C4 = 0.1 μF at V<sub>CC</sub> = 3.3 V ± 0.3 V; C1 = 0.047 μF, C2–C4 = 0.33 μF at V<sub>CC</sub> = 5 V ± 0.5 V.



## RECEIVER SECTION

electrical characteristics over recommended ranges of supply voltage and operating free-air temperature (unless otherwise noted) (see Note 3 and Figure 5)

PARAMETER	TEST CONDITIONS	MIN	TYP†	MAX	UNIT
V <sub>OH</sub> High-level output voltage	I <sub>OH</sub> = -1 mA	V <sub>CC</sub> - 0.6 V	V <sub>CC</sub> - 0.1 V		V
V <sub>OL</sub> Low-level output voltage	I <sub>OL</sub> = 1.6 mA			0.4	V
V <sub>IT+</sub> Positive-going input threshold voltage	V <sub>CC</sub> = 3.3 V		1.5	2.4	V
	V <sub>CC</sub> = 5 V		1.8	2.4	
V <sub>IT-</sub> Negative-going input threshold voltage	V <sub>CC</sub> = 3.3 V	0.6	1.2		V
	V <sub>CC</sub> = 5 V	0.8	1.5		
V <sub>hys</sub> Input hysteresis (V <sub>IT+</sub> - V <sub>IT-</sub> )			0.3		V
I <sub>off</sub> Output leakage current	$\overline{\text{EN}} = V_{\text{CC}}$		±0.05	±10	μA
r <sub>i</sub> Input resistance	V <sub>I</sub> = ±3 V to ±25 V	3	5	7	kΩ

† All typical values are at V<sub>CC</sub> = 3.3 V or V<sub>CC</sub> = 5 V, and T<sub>A</sub> = 25°C.

NOTE 3: Test conditions are C1–C4 = 0.1 μF at V<sub>CC</sub> = 3.3 V ± 0.3 V; C1 = 0.047 μF, C2–C4 = 0.33 μF at V<sub>CC</sub> = 5 V ± 0.5 V.

switching characteristics over recommended ranges of supply voltage and operating free-air temperature (unless otherwise noted) (see Note 3)

PARAMETER	TEST CONDITIONS	MIN	TYP†	MAX	UNIT
t <sub>PLH</sub> Propagation delay time, low- to high-level output	C <sub>L</sub> = 150 pF, See Figure 3		300		ns
t <sub>PHL</sub> Propagation delay time, high- to low-level output	C <sub>L</sub> = 150 pF, See Figure 3		300		ns
t <sub>en</sub> Output enable time	C <sub>L</sub> = 150 pF, R <sub>L</sub> = 3 kΩ, See Figure 4		200		ns
t <sub>dis</sub> Output disable time	C <sub>L</sub> = 150 pF, R <sub>L</sub> = 3 kΩ, See Figure 4		200		ns
t <sub>sk(p)</sub> Pulse skew‡	See Figure 3		300		ns

† All typical values are at V<sub>CC</sub> = 3.3 V or V<sub>CC</sub> = 5 V, and T<sub>A</sub> = 25°C.

‡ Pulse skew is defined as |t<sub>PLH</sub> - t<sub>PHL</sub>| of each channel of the same device.

NOTE 3: Test conditions are C1–C4 = 0.1 μF at V<sub>CC</sub> = 3.3 V ± 0.3 V; C1 = 0.047 μF, C2–C4 = 0.33 μF at V<sub>CC</sub> = 5 V ± 0.5 V.

# MAX3222

## 3-V TO 5.5-V MULTICHANNEL RS-232 LINE DRIVER/RECEIVER

SLLS408C – JANUARY 2000 – REVISED AUGUST 2002

### PARAMETER MEASUREMENT INFORMATION

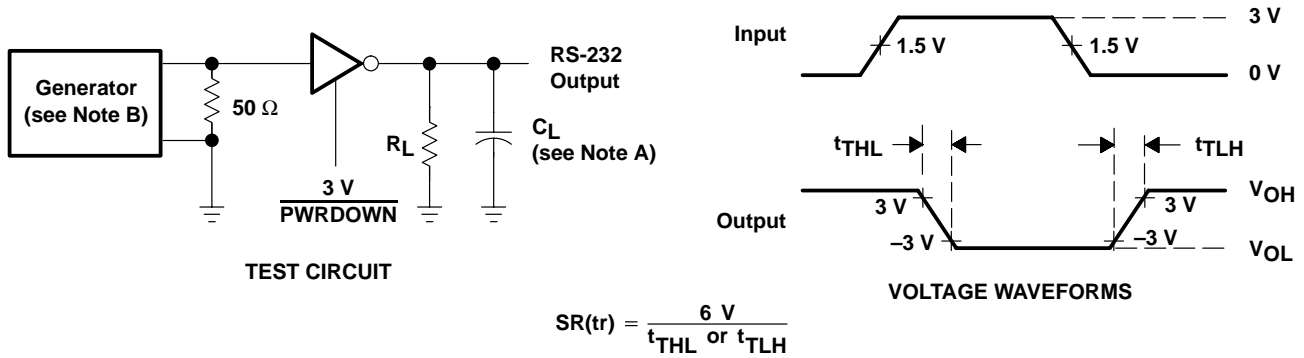

NOTES: A.  $C_L$  includes probe and jig capacitance.  
 B. The pulse generator has the following characteristics: PRR = 250 kbit/s,  $Z_O = 50\ \Omega$ , 50% duty cycle,  $t_r \leq 10\text{ ns}$ ,  $t_f \leq 10\text{ ns}$ .

Figure 1. Driver Slew Rate

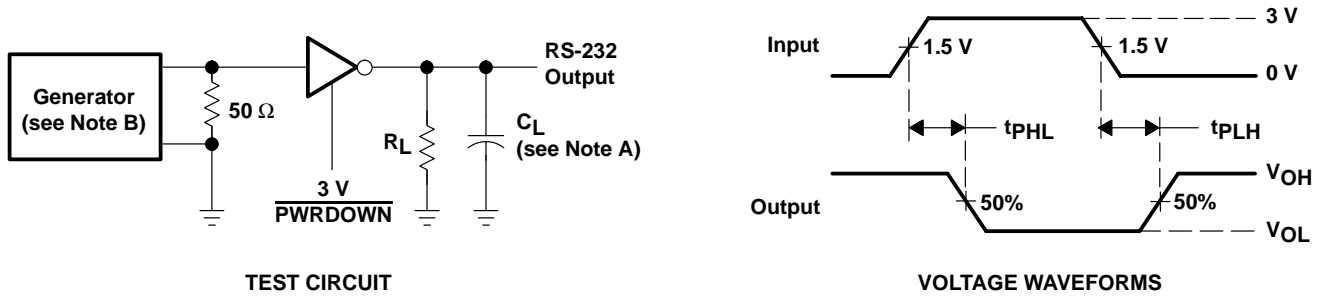

NOTES: A.  $C_L$  includes probe and jig capacitance.  
 B. The pulse generator has the following characteristics: PRR = 250 kbit/s,  $Z_O = 50\ \Omega$ , 50% duty cycle,  $t_r \leq 10\text{ ns}$ ,  $t_f \leq 10\text{ ns}$ .

Figure 2. Driver Pulse Skew

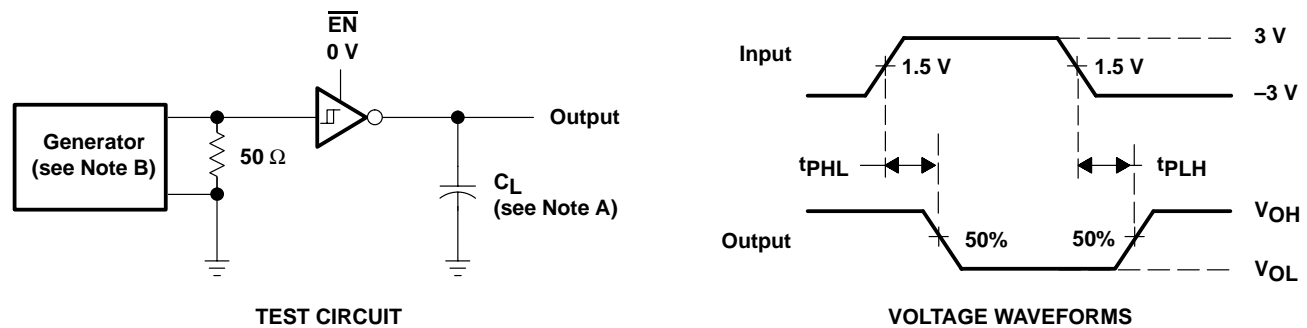

NOTES: A.  $C_L$  includes probe and jig capacitance.  
 B. The pulse generator has the following characteristics:  $Z_O = 50\ \Omega$ , 50% duty cycle,  $t_r \leq 10\text{ ns}$ ,  $t_f \leq 10\text{ ns}$ .

Figure 3. Receiver Propagation Delay Times

**PARAMETER MEASUREMENT INFORMATION**

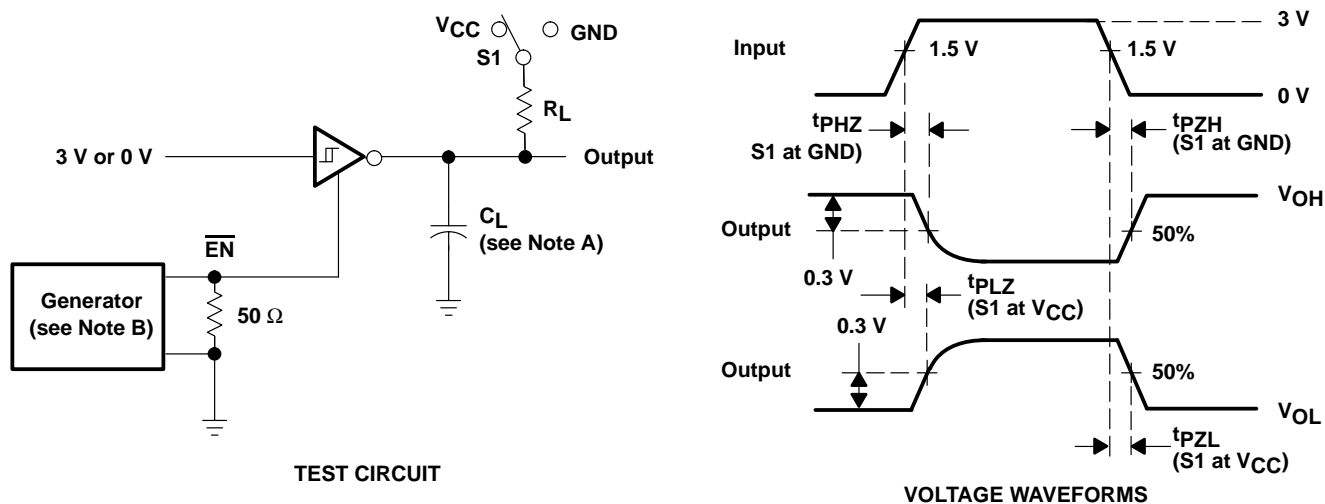

- NOTES: A.  $C_L$  includes probe and jig capacitance.  
 B. The pulse generator has the following characteristics:  $Z_O = 50 \Omega$ , 50% duty cycle,  $t_r \leq 10 \text{ ns}$ ,  $t_f \leq 10 \text{ ns}$ .

**Figure 4. Receiver Enable and Disable Times**

# MAX3222

## 3-V TO 5.5-V MULTICHANNEL RS-232 LINE DRIVER/RECEIVER

SLLS408C – JANUARY 2000 – REVISED AUGUST 2002

### APPLICATION INFORMATION

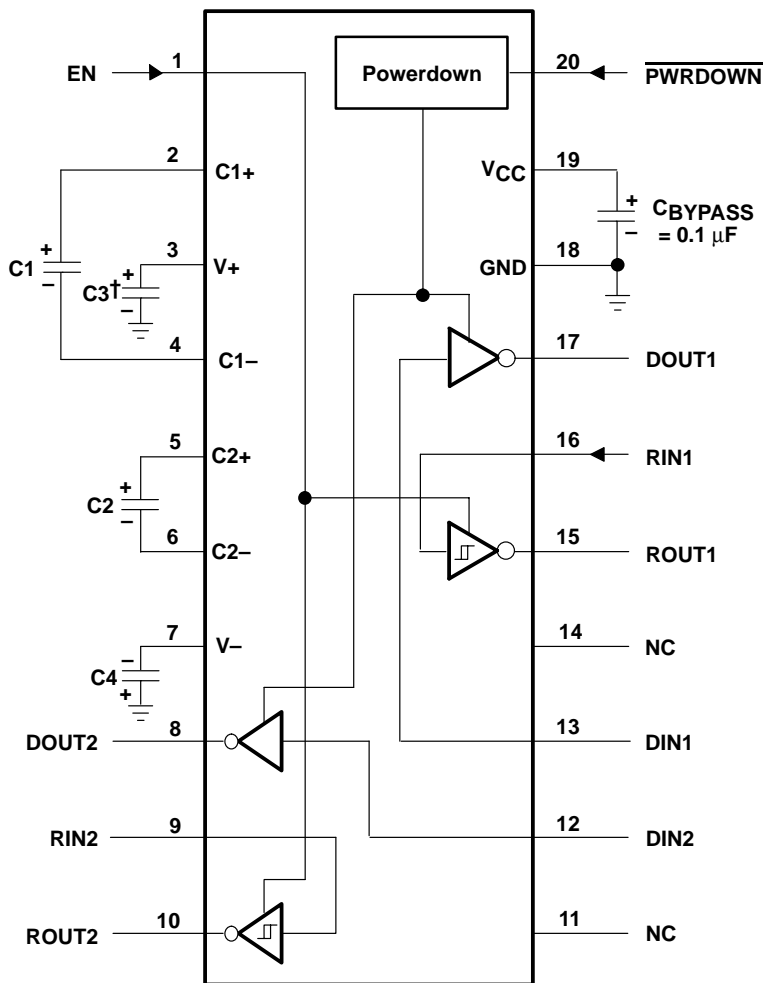

† C3 can be connected to V<sub>CC</sub> or GND.  
 NOTES: A. Resistor values shown are nominal.  
 B. NC – No internal connection.

#### V<sub>CC</sub> vs CAPACITOR VALUES

V <sub>CC</sub>	C1	C2, C3, and C4
3.3 V ± 0.3 V	0.1 μF	0.1 μF
5 V ± 0.5 V	0.047 μF	0.33 μF
3 V to 5.5 V	0.1 μF	0.47 μF

Figure 5. Typical Operating Circuit and Capacitor Values

## IMPORTANT NOTICE

Texas Instruments Incorporated and its subsidiaries (TI) reserve the right to make corrections, modifications, enhancements, improvements, and other changes to its products and services at any time and to discontinue any product or service without notice. Customers should obtain the latest relevant information before placing orders and should verify that such information is current and complete. All products are sold subject to TI's terms and conditions of sale supplied at the time of order acknowledgment.

TI warrants performance of its hardware products to the specifications applicable at the time of sale in accordance with TI's standard warranty. Testing and other quality control techniques are used to the extent TI deems necessary to support this warranty. Except where mandated by government requirements, testing of all parameters of each product is not necessarily performed.

TI assumes no liability for applications assistance or customer product design. Customers are responsible for their products and applications using TI components. To minimize the risks associated with customer products and applications, customers should provide adequate design and operating safeguards.

TI does not warrant or represent that any license, either express or implied, is granted under any TI patent right, copyright, mask work right, or other TI intellectual property right relating to any combination, machine, or process in which TI products or services are used. Information published by TI regarding third-party products or services does not constitute a license from TI to use such products or services or a warranty or endorsement thereof. Use of such information may require a license from a third party under the patents or other intellectual property of the third party, or a license from TI under the patents or other intellectual property of TI.

Reproduction of information in TI data books or data sheets is permissible only if reproduction is without alteration and is accompanied by all associated warranties, conditions, limitations, and notices. Reproduction of this information with alteration is an unfair and deceptive business practice. TI is not responsible or liable for such altered documentation.

Resale of TI products or services with statements different from or beyond the parameters stated by TI for that product or service voids all express and any implied warranties for the associated TI product or service and is an unfair and deceptive business practice. TI is not responsible or liable for any such statements.

### Mailing Address:

Texas Instruments  
Post Office Box 655303  
Dallas, Texas 75265