



The MAX3237E transmitters are disabled and the outputs are forced into high-impedance state when the device is in shutdown mode ( $\overline{\text{SHDN}} = \text{GND}$ ) and the supply current falls to less than 1  $\mu\text{A}$ . Also, during shutdown, the onboard charge pump is disabled;  $V_+$  is lowered to  $V_{\text{CC}}$ , and  $V_-$  is raised toward GND. Receiver outputs also can be placed in the high-impedance state by setting enable (EN) high. ROUT1B remains active all the time, regardless of the EN and SHDN condition.

The MAX3237EC is characterized for operation from 0°C to 70°C. The MAX3237EI is characterized for operation from –40°C to 85°C.

#### AVAILABLE OPTIONS<sup>(1)</sup>

$T_A$	PACKAGED DEVICES <sup>(2)</sup>
0°C to 70°C	MAX3237ECDBR
	MAX3237ECPWR
	MAX3237ECRHBR (QFN package)
	MAX3237ECDWR
–40°C to 85°C	MAX3237EIDBR
	MAX3237EIPWR
	MAX3237EIRHBR (QFN package)
	MAX3237EIDWR

- (1) For the most current package and ordering information, see the Package Option Addendum at the end of this document, or see the TI web site at [www.ti.com](http://www.ti.com).
- (2) Package drawings, thermal data, and symbolization are available at [www.ti.com/packaging](http://www.ti.com/packaging).

**Table 1. FUNCTION TABLE**

INPUTS		OUTPUTS		
$\overline{\text{SHDN}}$	$\overline{\text{EN}}$	DOUT	ROUT	ROUT1B
0	0	Z <sup>(1)</sup>	Active	Active
0	1	Z <sup>(1)</sup>	Z <sup>(1)</sup>	Active
1	0	Active	Active	Active
1	1	Active	Z <sup>(1)</sup>	Active

- (1) Z = high impedance (off)

LOGIC DIAGRAM (POSITIVE LOGIC)

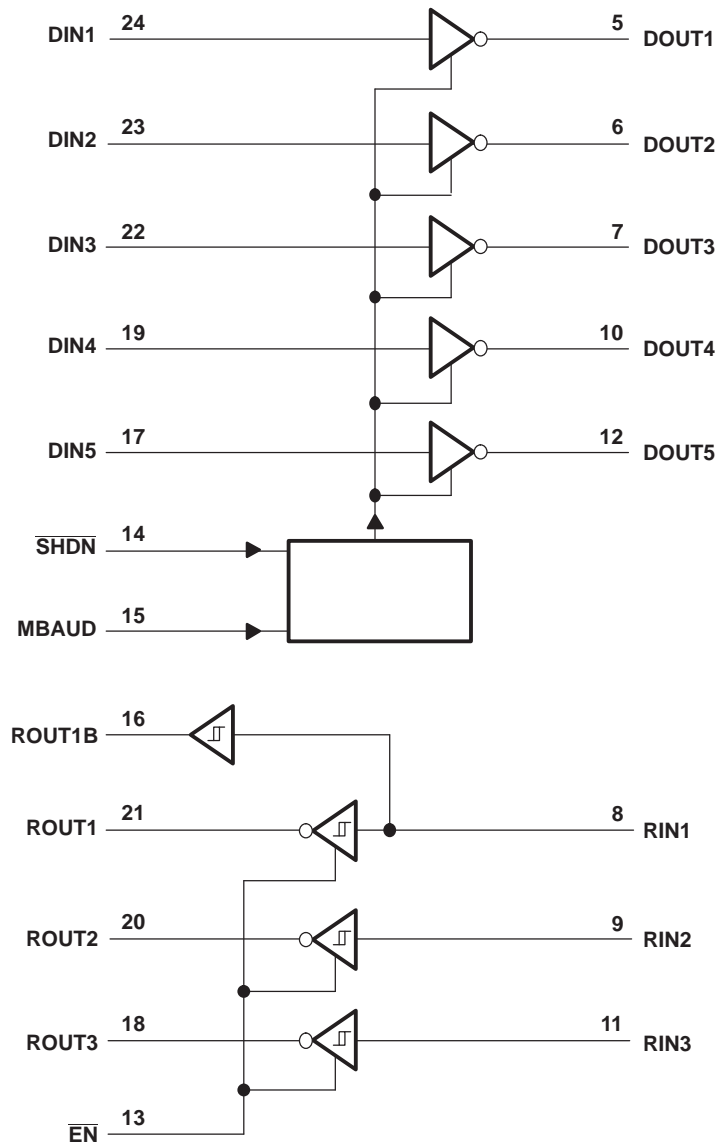

## ABSOLUTE MAXIMUM RATINGS<sup>(1)</sup>

over operating free-air temperature range (unless otherwise noted)

		MIN	MAX	UNIT	
V <sub>CC</sub>	Supply voltage range <sup>(2)</sup>	-0.3	6	V	
V+	Positive-output supply voltage range <sup>(2)</sup>	-0.3	7	V	
V-	Negative-output supply voltage range <sup>(2)</sup>	0.3	-7	V	
V+ - V-	Supply voltage difference <sup>(2)</sup>		13	V	
V <sub>I</sub>	Input voltage range	Driver ( $\overline{\text{SHDN}}$ , MBAUD, $\overline{\text{EN}}$ )	-0.3	6	V
		Receiver	-25	25	
V <sub>O</sub>	Output voltage range	Driver	-13.2	13.2	V
		Receiver	-0.3	V <sub>CC</sub> + 0.3	
	Short-circuit duration	DOUT to GND		Unlimited	
θ <sub>JA</sub>	Package thermal impedance <sup>(3)</sup>		62	°C/W	
T <sub>stg</sub>	Storage temperature range	-65	150	°C	

- (1) Stresses beyond those listed under "absolute maximum ratings" may cause permanent damage to the device. These are stress ratings only, and functional operation of the device at these or any other conditions beyond those indicated under "recommended operating conditions" is not implied. Exposure to absolute-maximum-rated conditions for extended periods may affect device reliability.
- (2) All voltages are with respect to network GND.
- (3) The package thermal impedance is calculated in accordance with JESD 51-7.

## RECOMMENDED OPERATING CONDITIONS<sup>(1)</sup>

See [Figure 5](#)

		MIN	NOM	MAX	UNIT	
Supply voltage		V <sub>CC</sub> = 3.3 V	3	3.3	3.6	V
		V <sub>CC</sub> = 5 V	4.5	5	5.5	
V <sub>IH</sub>	Driver and control high-level input voltage	DIN, $\overline{\text{SHDN}}$ , MBAUD, $\overline{\text{EN}}$	V <sub>CC</sub> = 3.3 V	2	5.5	V
			V <sub>CC</sub> = 5 V	2.4	5.5	
V <sub>IL</sub>	Driver and control low-level input voltage	DIN, $\overline{\text{SHDN}}$ , MBAUD, $\overline{\text{EN}}$		0	0.8	V
V <sub>I</sub>	Receiver input voltage	-25		25	V	
T <sub>A</sub>	Operating free-air temperature	MAX3237EC	0	70	°C	
		MAX3237EI	-40	85		

- (1) Test conditions are C1–C4 = 0.1 μF at V<sub>CC</sub> = 3 V to 5 V.

## ELECTRICAL CHARACTERISTICS<sup>(1)</sup>

over recommended ranges of supply voltage and operating free-air temperature (unless otherwise noted) (see [Figure 5](#))

PARAMETER		TEST CONDITIONS	MIN	TYP <sup>(2)</sup>	MAX	UNIT	
I <sub>I</sub>	Input leakage current	DIN, $\overline{\text{SHDN}}$ , MBAUD, $\overline{\text{EN}}$		9	18	μA	
I <sub>CC</sub>	Supply current (T <sub>A</sub> = 25°C)	No load, $\overline{\text{SHDN}} = V_{CC}$		0.5	2	mA	
		Shutdown supply current	$\overline{\text{SHDN}} = \text{GND}$		1	10	μA
			$\overline{\text{SHDN}} = \text{RIN} = \text{GND}$ , DIN = GND or V <sub>CC</sub>		10	300	nA

- (1) Test conditions are C1–C4 = 0.1 μF at V<sub>CC</sub> = 3 V to 5 V.
- (2) All typical values are at V<sub>CC</sub> = 3.3 V or V<sub>CC</sub> = 5 V, and T<sub>A</sub> = 25°C.

## DRIVER SECTION ELECTRICAL CHARACTERISTICS<sup>(1)</sup>

over recommended ranges of supply voltage and operating free-air temperature (unless otherwise noted) (see [Figure 5](#))

PARAMETER		TEST CONDITIONS		MIN	TYP <sup>(2)</sup>	MAX	UNIT
V <sub>OH</sub>	High-level output voltage	DOUT at R <sub>L</sub> = 3 kΩ to GND,	DIN = GND	5	5.4		V
V <sub>OL</sub>	Low-level output voltage	DOUT at R <sub>L</sub> = 3 kΩ to GND,	DIN = V <sub>CC</sub>	-5	-5.4		V
I <sub>IH</sub>	High-level input current	V <sub>I</sub> = V <sub>CC</sub>			±0.01	±1	μA
I <sub>IL</sub>	Low-level input current	V <sub>I</sub> at GND			±0.01	±1	μA
I <sub>OS</sub>	Short-circuit output current <sup>(3)</sup>	V <sub>CC</sub> = 3.6 V or 3.3 V,	V <sub>O</sub> = 0 V			±60	mA
r <sub>o</sub>	Output resistance	V <sub>CC</sub> , V+, and V- = 0 V,	V <sub>O</sub> = ±2 V	300	50k		Ω

(1) Test conditions are C1–C4 = 0.1 μF at V<sub>CC</sub> = 3 V to 5 V.

(2) All typical values are at V<sub>CC</sub> = 3.3 V or V<sub>CC</sub> = 5 V, and T<sub>A</sub> = 25°C.

(3) Short-circuit durations should be controlled to prevent exceeding the device absolute power-dissipation ratings, and not more than one output should be shorted at a time.

## DRIVER SECTION SWITCHING CHARACTERISTICS<sup>(1)</sup>

over recommended ranges of supply voltage and operating free-air temperature (unless otherwise noted) (see [Figure 5](#))

PARAMETER		TEST CONDITIONS		MIN	TYP <sup>(2)</sup>	MAX	UNIT
Maximum data rate	C <sub>L</sub> = 1000 pF, MBAUD = GND	R <sub>L</sub> = 3 kΩ, 1 DIN switching, See <a href="#">Figure 1</a>		250			kbit/s
	C <sub>L</sub> = 1000 pF, V <sub>CC</sub> = 4.5 V to 5.5 V, MBAUD = V <sub>CC</sub>			1000			
	C <sub>L</sub> = 250 pF, V <sub>CC</sub> = 3 V to 4.5 V, MBAUD = V <sub>CC</sub>			1000			
t <sub>sk(p)</sub>	Pulse skew <sup>(3)</sup>	C <sub>L</sub> = 150 pF to 2500 pF, R <sub>L</sub> = 3 kΩ to 7 kΩ, MBAUD = V <sub>CC</sub> or GND, See <a href="#">Figure 2</a>			100		ns
SR(tr)	Slew rate, transition region (see <a href="#">Figure 1</a> )	V <sub>CC</sub> = 3.3 V, R <sub>L</sub> = 3 kΩ to 7 kΩ, T <sub>A</sub> = 25°C	C <sub>L</sub> = 150 pF to 1000 pF	MBAUD = GND	6	30	V/μs
				MBAUD = V <sub>CC</sub>	24	150	
			C <sub>L</sub> = 150 pF to 2500 pF,	MBAUD = GND	4	30	

(1) Test conditions are C1–C4 = 0.1 μF at V<sub>CC</sub> = 3 V to 5 V.

(2) All typical values are at V<sub>CC</sub> = 3.3 V or V<sub>CC</sub> = 5 V, and T<sub>A</sub> = 25°C.

(3) Pulse skew is defined as |t<sub>PLH</sub> – t<sub>PHL</sub>| of each channel of the same device.

## RECEIVER SECTION ELECTRICAL CHARACTERISTICS<sup>(1)</sup>

over recommended ranges of supply voltage and operating free-air temperature (unless otherwise noted) (see [Figure 5](#))

PARAMETER		TEST CONDITIONS	MIN	TYP <sup>(2)</sup>	MAX	UNIT
V <sub>OH</sub>	High-level output voltage	I <sub>OH</sub> = -1 mA	V <sub>CC</sub> - 0.6	V <sub>CC</sub> - 0.1		V
V <sub>OL</sub>	Low-level output voltage	I <sub>OL</sub> = 1 mA			0.4	V
V <sub>IT+</sub>	Positive-going input threshold voltage	V <sub>CC</sub> = 3.3 V		1.5	2.4	V
		V <sub>CC</sub> = 5 V		2	2.4	
V <sub>IT-</sub>	Negative-going input threshold voltage	V <sub>CC</sub> = 3.3 V	0.6	1.1		V
		V <sub>CC</sub> = 5 V	0.8	1.5		
V <sub>hys</sub>	Input hysteresis (V <sub>IT+</sub> - V <sub>IT-</sub> )			0.5		V
I <sub>oz</sub>	Output leakage current	$\overline{EN} = V_{CC}$		±0.05	±10	µA
r <sub>i</sub>	Input resistance	V <sub>i</sub> = ±3 V to ±25 V	3	5	7	kΩ

(1) Test conditions are C1–C4 = 0.1 mF at V<sub>CC</sub> = 3 V to 5 V.

(2) All typical values are at V<sub>CC</sub> = 3.3 V or V<sub>CC</sub> = 5 V, and T<sub>A</sub> = 25°C.

## RECEIVER SECTION SWITCHING CHARACTERISTICS<sup>(1)</sup>

over recommended ranges of supply voltage and operating free-air temperature (unless otherwise noted)

PARAMETER		TEST CONDITIONS	TYP <sup>(2)</sup>	UNIT
t <sub>PLH</sub>	Propagation delay time, low- to high-level output	C <sub>L</sub> = 150 pF, See <a href="#">Figure 3</a>	150	ns
t <sub>PHL</sub>	Propagation delay time, high- to low-level output	C <sub>L</sub> = 150 pF, See <a href="#">Figure 3</a>	150	ns
t <sub>en</sub>	Output enable time	C <sub>L</sub> = 150 pF, R <sub>L</sub> = 3 kΩ, See <a href="#">Figure 4</a>	2.6	µs
t <sub>dis</sub>	Output disable time	C <sub>L</sub> = 150 pF, R <sub>L</sub> = 3 kΩ, See <a href="#">Figure 4</a>	2.4	µs
t <sub>sk(p)</sub>	Pulse skew <sup>(3)</sup>	See <a href="#">Figure 3</a>	50	ns

(1) Test conditions are C1–C4 = 0.1 µF at V<sub>CC</sub> = 3 V to 5 V.

(2) All typical values are at V<sub>CC</sub> = 3.3 V or V<sub>CC</sub> = 5 V, and T<sub>A</sub> = 25°C.

(3) Pulse skew is defined as |t<sub>PLH</sub> - t<sub>PHL</sub>| of each channel of the same device.

## ESD PROTECTION

PIN	TEST CONDITIONS	TYP	UNIT
DOUT, RIN	HBM	±15	kV
	IEC61000-4-2, Contact Discharge	±8	
	IEC61000-4-2, Air-Gap Discharge	±15	

PARAMETER MEASUREMENT INFORMATION

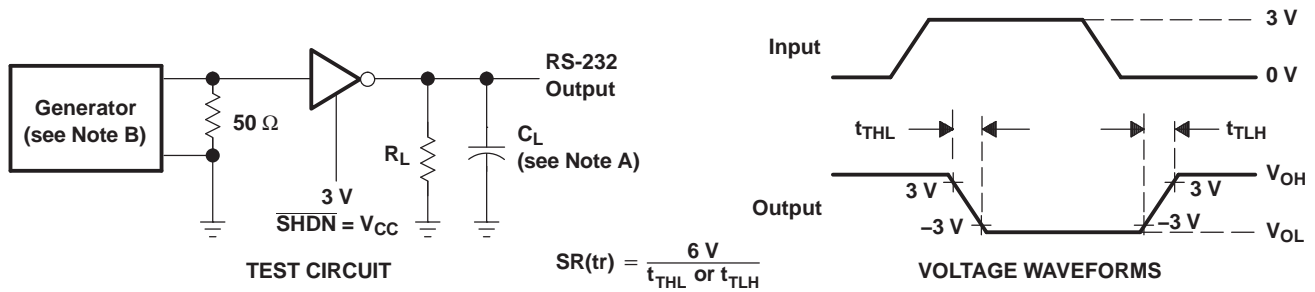

NOTES: A. C<sub>L</sub> includes probe and jig capacitance.  
 B. The pulse generator has the following characteristics: PRR = 250 kbit/s, Z<sub>O</sub> = 50 Ω, 50% duty cycle, t<sub>r</sub> ≤ 10 ns, t<sub>f</sub> ≤ 10 ns.

Figure 1. Driver Slew Rate

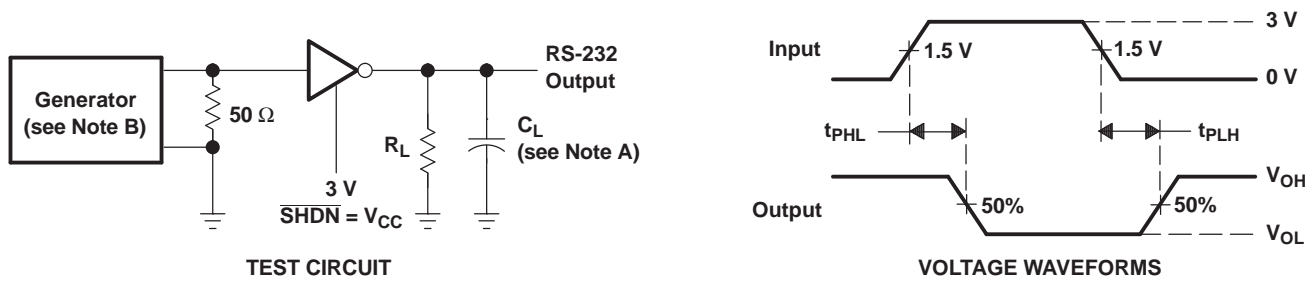

NOTES: A. C<sub>L</sub> includes probe and jig capacitance.  
 B. The pulse generator has the following characteristics: PRR = 250 kbit/s, Z<sub>O</sub> = 50 Ω, 50% duty cycle, t<sub>r</sub> ≤ 10 ns, t<sub>f</sub> ≤ 10 ns.

Figure 2. Driver Pulse Skew

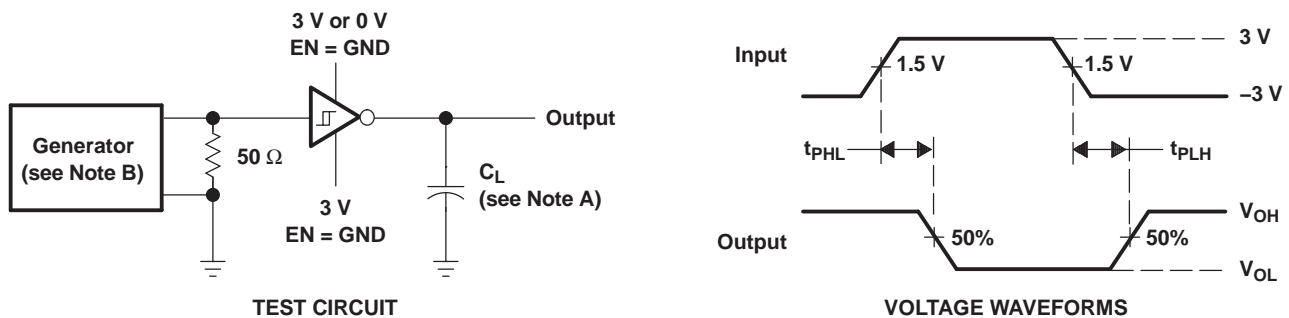

NOTES: A. C<sub>L</sub> includes probe and jig capacitance.  
 B. The pulse generator has the following characteristics: Z<sub>O</sub> = 50 Ω, 50% duty cycle, t<sub>r</sub> ≤ 10 ns, t<sub>f</sub> ≤ 10 ns.

Figure 3. Receiver Propagation Delay Times

PARAMETER MEASUREMENT INFORMATION (continued)

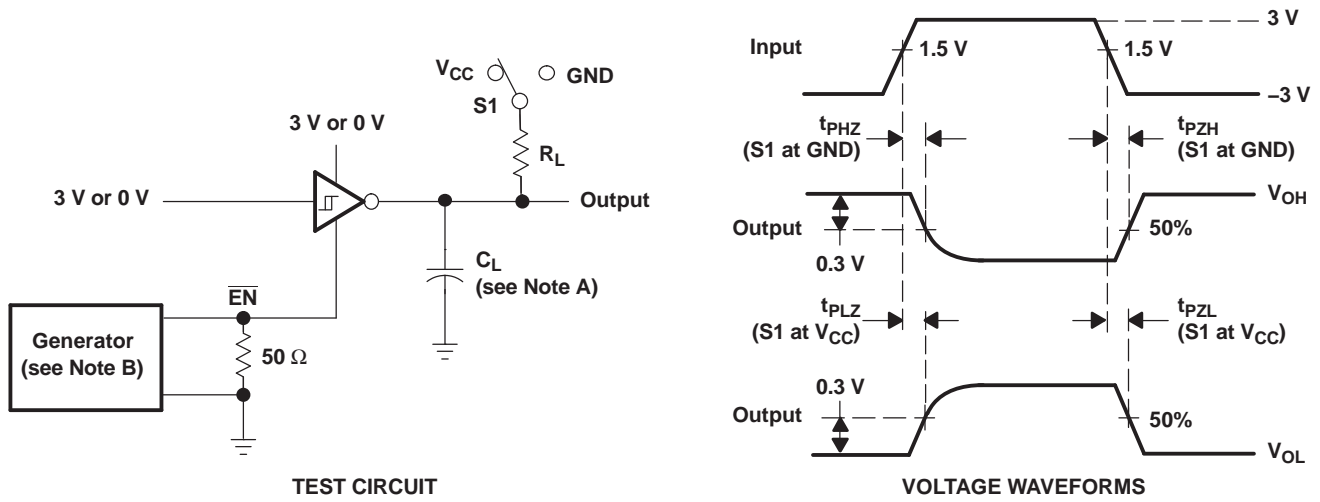

- NOTES: A.  $C_L$  includes probe and jig capacitance.  
 B. The pulse generator has the following characteristics:  $Z_O = 50 \Omega$ , 50% duty cycle,  $t_r \leq 10 \text{ ns}$ ,  $t_f \leq 10 \text{ ns}$ .  
 C.  $t_{PLZ}$  and  $t_{PHZ}$  are the same as  $t_{dis}$ .  
 D.  $t_{PZL}$  and  $t_{PZH}$  are the same as  $t_{en}$ .

Figure 4. Receiver Enable and Disable Times

APPLICATION INFORMATION

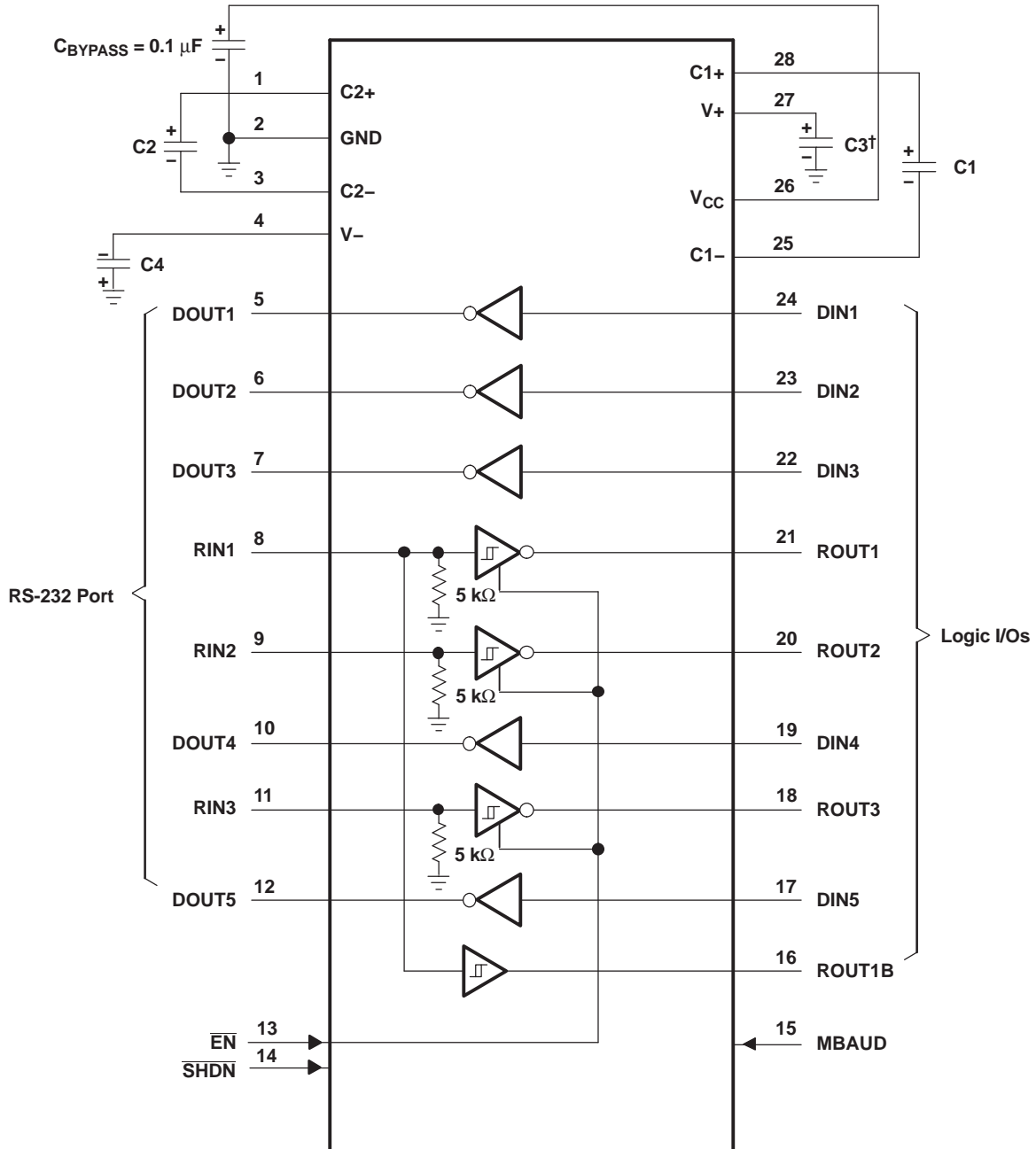

† C3 can be connected to V<sub>CC</sub> or GND.

NOTES: A. Resistor values shown are nominal.

B. Nonpolarized ceramic capacitors are acceptable. If polarized tantalum or electrolytic capacitors are used, they should be connected as shown.

V<sub>CC</sub> vs CAPACITOR VALUES

V <sub>CC</sub>	C1	C2, C3, and C4
3.3 V ± 0.15 V	0.1 μF	0.1 μF
3.3 V ± 0.3 V	0.22 μF	0.22 μF
5 V ± 0.5 V	0.047 μF	0.33 μF
3 V to 5.5 V	0.22 μF	1 μF

Figure 5. Typical Operating Circuit and Capacitor Values

**PACKAGING INFORMATION**

Orderable Device	Status (1)	Package Type	Package Drawing	Pins	Package Qty	Eco Plan (2)	Lead/Ball Finish	MSL Peak Temp (3)	Op Temp (°C)	Top-Side Markings (4)	Samples
MAX3237ECDB	ACTIVE	SSOP	DB	28	50	Green (RoHS & no Sb/Br)	CU NIPDAU	Level-1-260C-UNLIM	0 to 70	MAX3237EC	<a href="#">Samples</a>
MAX3237ECDBG4	ACTIVE	SSOP	DB	28	50	Green (RoHS & no Sb/Br)	CU NIPDAU	Level-1-260C-UNLIM	0 to 70	MAX3237EC	<a href="#">Samples</a>
MAX3237ECDBR	ACTIVE	SSOP	DB	28	2000	Green (RoHS & no Sb/Br)	CU NIPDAU	Level-1-260C-UNLIM	0 to 70	MAX3237EC	<a href="#">Samples</a>
MAX3237ECDBRG4	ACTIVE	SSOP	DB	28	2000	Green (RoHS & no Sb/Br)	CU NIPDAU	Level-1-260C-UNLIM	0 to 70	MAX3237EC	<a href="#">Samples</a>
MAX3237ECDW	ACTIVE	SOIC	DW	28	20	Green (RoHS & no Sb/Br)	CU NIPDAU	Level-1-260C-UNLIM	0 to 70	MAX3237EC	<a href="#">Samples</a>
MAX3237ECDWG4	ACTIVE	SOIC	DW	28	20	Green (RoHS & no Sb/Br)	CU NIPDAU	Level-1-260C-UNLIM	0 to 70	MAX3237EC	<a href="#">Samples</a>
MAX3237ECDWR	ACTIVE	SOIC	DW	28	1000	Green (RoHS & no Sb/Br)	CU NIPDAU	Level-1-260C-UNLIM	0 to 70	MAX3237EC	<a href="#">Samples</a>
MAX3237ECDWRG4	ACTIVE	SOIC	DW	28	1000	Green (RoHS & no Sb/Br)	CU NIPDAU	Level-1-260C-UNLIM	0 to 70	MAX3237EC	<a href="#">Samples</a>
MAX3237ECPW	ACTIVE	TSSOP	PW	28	50	Green (RoHS & no Sb/Br)	CU NIPDAU	Level-1-260C-UNLIM	0 to 70	MP237EC	<a href="#">Samples</a>
MAX3237ECPWG4	ACTIVE	TSSOP	PW	28	50	Green (RoHS & no Sb/Br)	CU NIPDAU	Level-1-260C-UNLIM	0 to 70	MP237EC	<a href="#">Samples</a>
MAX3237ECPWR	ACTIVE	TSSOP	PW	28	2000	Green (RoHS & no Sb/Br)	CU NIPDAU	Level-1-260C-UNLIM	0 to 70	MP237EC	<a href="#">Samples</a>
MAX3237ECPWRG4	ACTIVE	TSSOP	PW	28	2000	Green (RoHS & no Sb/Br)	CU NIPDAU	Level-1-260C-UNLIM	0 to 70	MP237EC	<a href="#">Samples</a>
MAX3237EIDB	ACTIVE	SSOP	DB	28	50	Green (RoHS & no Sb/Br)	CU NIPDAU	Level-1-260C-UNLIM	-40 to 85	MAX3237EI	<a href="#">Samples</a>
MAX3237EIDBG4	ACTIVE	SSOP	DB	28	50	Green (RoHS & no Sb/Br)	CU NIPDAU	Level-1-260C-UNLIM	-40 to 85	MAX3237EI	<a href="#">Samples</a>
MAX3237EIDBR	ACTIVE	SSOP	DB	28	2000	Green (RoHS & no Sb/Br)	CU NIPDAU	Level-1-260C-UNLIM	-40 to 85	MAX3237EI	<a href="#">Samples</a>
MAX3237EIDBRG4	ACTIVE	SSOP	DB	28	2000	Green (RoHS & no Sb/Br)	CU NIPDAU	Level-1-260C-UNLIM	-40 to 85	MAX3237EI	<a href="#">Samples</a>
MAX3237EIDW	ACTIVE	SOIC	DW	28	20	Green (RoHS & no Sb/Br)	CU NIPDAU	Level-1-260C-UNLIM	-40 to 85	MAX3237EI	<a href="#">Samples</a>

Orderable Device	Status (1)	Package Type	Package Drawing	Pins	Package Qty	Eco Plan (2)	Lead/Ball Finish	MSL Peak Temp (3)	Op Temp (°C)	Top-Side Markings (4)	Samples
MAX3237EIDWG4	ACTIVE	SOIC	DW	28	20	Green (RoHS & no Sb/Br)	CU NIPDAU	Level-1-260C-UNLIM	-40 to 85	MAX3237EI	<a href="#">Samples</a>
MAX3237EIDWR	ACTIVE	SOIC	DW	28	1000	Green (RoHS & no Sb/Br)	CU NIPDAU	Level-1-260C-UNLIM	-40 to 85	MAX3237EI	<a href="#">Samples</a>
MAX3237EIDWRG4	ACTIVE	SOIC	DW	28	1000	Green (RoHS & no Sb/Br)	CU NIPDAU	Level-1-260C-UNLIM	-40 to 85	MAX3237EI	<a href="#">Samples</a>
MAX3237EIPW	ACTIVE	TSSOP	PW	28	50	Green (RoHS & no Sb/Br)	CU NIPDAU	Level-1-260C-UNLIM	-40 to 85	MP237EI	<a href="#">Samples</a>
MAX3237EIPWG4	ACTIVE	TSSOP	PW	28	50	Green (RoHS & no Sb/Br)	CU NIPDAU	Level-1-260C-UNLIM	-40 to 85	MP237EI	<a href="#">Samples</a>
MAX3237EIPWR	ACTIVE	TSSOP	PW	28	2000	Green (RoHS & no Sb/Br)	CU NIPDAU	Level-1-260C-UNLIM	-40 to 85	MP237EI	<a href="#">Samples</a>
MAX3237EIPWRG4	ACTIVE	TSSOP	PW	28	2000	Green (RoHS & no Sb/Br)	CU NIPDAU	Level-1-260C-UNLIM	-40 to 85	MP237EI	<a href="#">Samples</a>

(1) The marketing status values are defined as follows:

**ACTIVE:** Product device recommended for new designs.

**LIFEBUY:** TI has announced that the device will be discontinued, and a lifetime-buy period is in effect.

**NRND:** Not recommended for new designs. Device is in production to support existing customers, but TI does not recommend using this part in a new design.

**PREVIEW:** Device has been announced but is not in production. Samples may or may not be available.

**OBSOLETE:** TI has discontinued the production of the device.

(2) Eco Plan - The planned eco-friendly classification: Pb-Free (RoHS), Pb-Free (RoHS Exempt), or Green (RoHS & no Sb/Br) - please check <http://www.ti.com/productcontent> for the latest availability information and additional product content details.

**TBD:** The Pb-Free/Green conversion plan has not been defined.

**Pb-Free (RoHS):** TI's terms "Lead-Free" or "Pb-Free" mean semiconductor products that are compatible with the current RoHS requirements for all 6 substances, including the requirement that lead not exceed 0.1% by weight in homogeneous materials. Where designed to be soldered at high temperatures, TI Pb-Free products are suitable for use in specified lead-free processes.

**Pb-Free (RoHS Exempt):** This component has a RoHS exemption for either 1) lead-based flip-chip solder bumps used between the die and package, or 2) lead-based die adhesive used between the die and leadframe. The component is otherwise considered Pb-Free (RoHS compatible) as defined above.

**Green (RoHS & no Sb/Br):** TI defines "Green" to mean Pb-Free (RoHS compatible), and free of Bromine (Br) and Antimony (Sb) based flame retardants (Br or Sb do not exceed 0.1% by weight in homogeneous material)

(3) MSL, Peak Temp. -- The Moisture Sensitivity Level rating according to the JEDEC industry standard classifications, and peak solder temperature.

(4) Only one of markings shown within the brackets will appear on the physical device.

**Important Information and Disclaimer:** The information provided on this page represents TI's knowledge and belief as of the date that it is provided. TI bases its knowledge and belief on information provided by third parties, and makes no representation or warranty as to the accuracy of such information. Efforts are underway to better integrate information from third parties. TI has taken and

continues to take reasonable steps to provide representative and accurate information but may not have conducted destructive testing or chemical analysis on incoming materials and chemicals. TI and TI suppliers consider certain information to be proprietary, and thus CAS numbers and other limited information may not be available for release.

In no event shall TI's liability arising out of such information exceed the total purchase price of the TI part(s) at issue in this document sold by TI to Customer on an annual basis.

## TAPE AND REEL INFORMATION

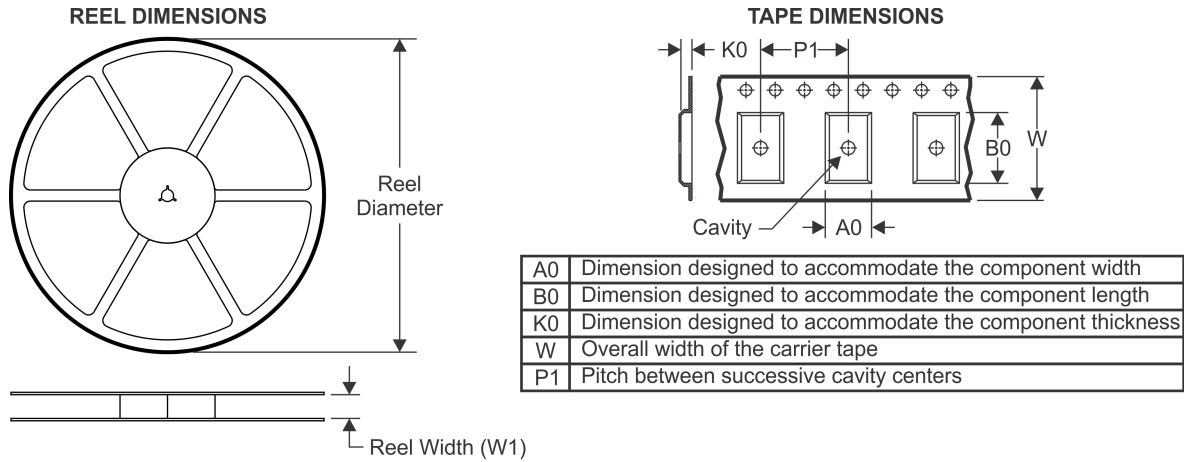

### QUADRANT ASSIGNMENTS FOR PIN 1 ORIENTATION IN TAPE



\*All dimensions are nominal

Device	Package Type	Package Drawing	Pins	SPQ	Reel Diameter (mm)	Reel Width W1 (mm)	A0 (mm)	B0 (mm)	K0 (mm)	P1 (mm)	W (mm)	Pin1 Quadrant
MAX3237ECDBR	SSOP	DB	28	2000	330.0	16.4	8.2	10.5	2.5	12.0	16.0	Q1
MAX3237ECDWR	SOIC	DW	28	1000	330.0	32.4	11.35	18.67	3.1	16.0	32.0	Q1
MAX3237ECPWR	TSSOP	PW	28	2000	330.0	16.4	6.9	10.2	1.8	12.0	16.0	Q1
MAX3237EIDBR	SSOP	DB	28	2000	330.0	16.4	8.2	10.5	2.5	12.0	16.0	Q1
MAX3237EIDWR	SOIC	DW	28	1000	330.0	32.4	11.35	18.67	3.1	16.0	32.0	Q1
MAX3237EIPWR	TSSOP	PW	28	2000	330.0	16.4	6.9	10.2	1.8	12.0	16.0	Q1

**TAPE AND REEL BOX DIMENSIONS**

\*All dimensions are nominal

Device	Package Type	Package Drawing	Pins	SPQ	Length (mm)	Width (mm)	Height (mm)
MAX3237ECDBR	SSOP	DB	28	2000	367.0	367.0	38.0
MAX3237ECDWR	SOIC	DW	28	1000	367.0	367.0	55.0
MAX3237ECPWR	TSSOP	PW	28	2000	367.0	367.0	38.0
MAX3237EIDBR	SSOP	DB	28	2000	367.0	367.0	38.0
MAX3237EIDWR	SOIC	DW	28	1000	367.0	367.0	55.0
MAX3237EIPWR	TSSOP	PW	28	2000	367.0	367.0	38.0

DW (R-PDSO-G28)

PLASTIC SMALL OUTLINE

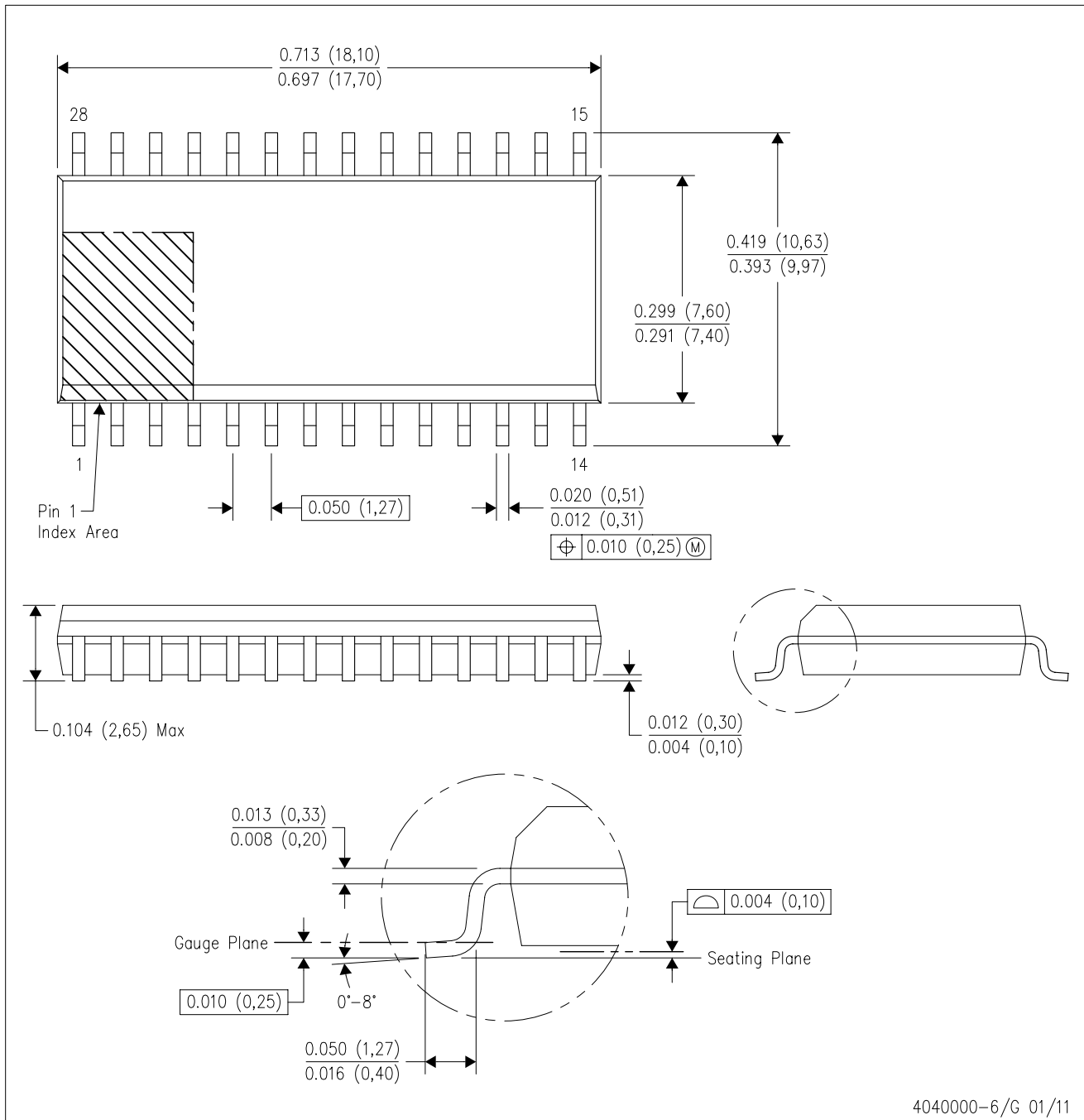

4040000-6/G 01/11

- NOTES:
- A. All linear dimensions are in inches (millimeters). Dimensioning and tolerancing per ASME Y14.5M-1994.
  - B. This drawing is subject to change without notice.
  - C. Body dimensions do not include mold flash or protrusion not to exceed 0.006 (0,15).
  - D. Falls within JEDEC MS-013 variation AE.



PW (R-PDSO-G28)

PLASTIC SMALL OUTLINE

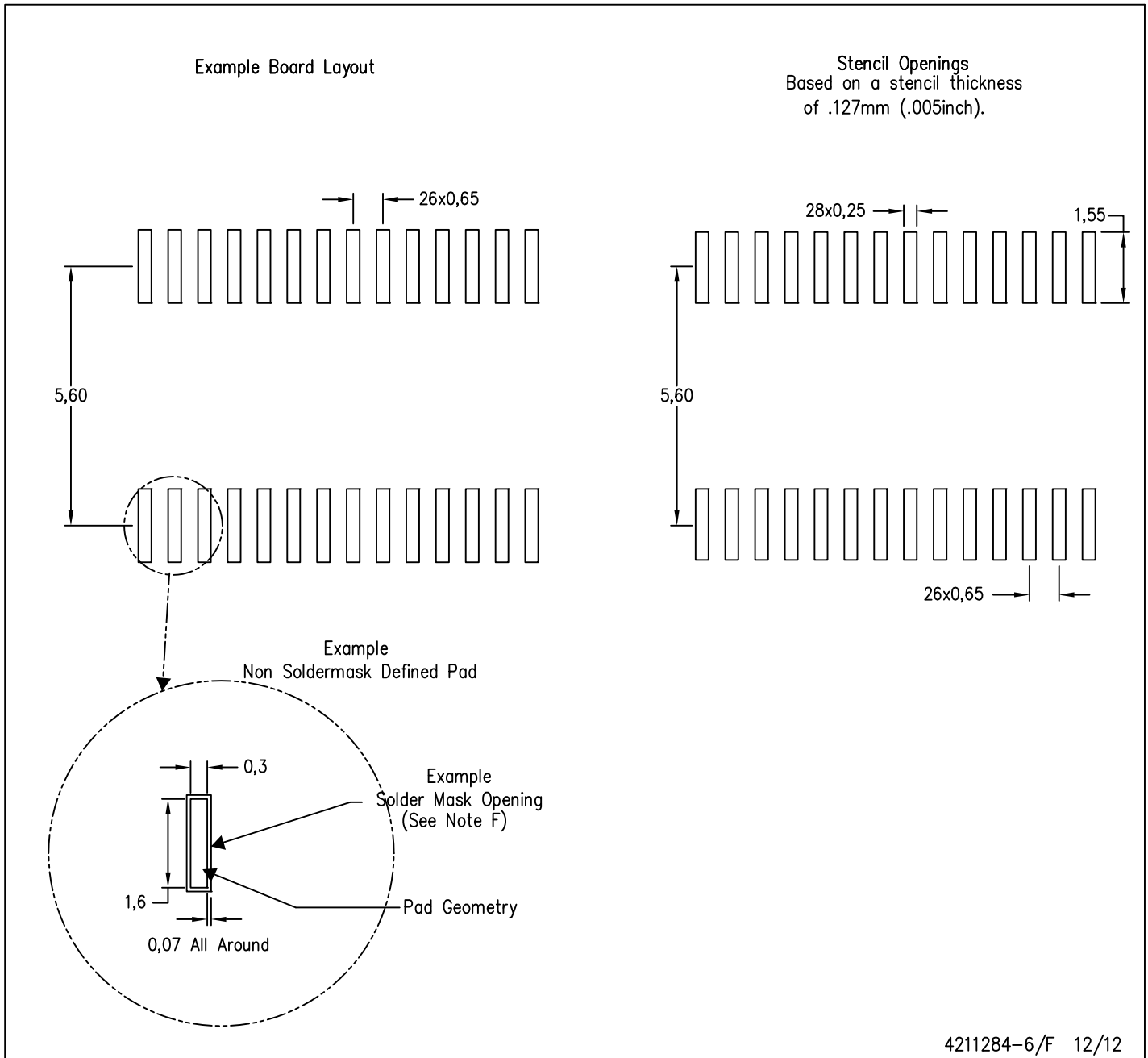

- NOTES:
- A. All linear dimensions are in millimeters.
  - B. This drawing is subject to change without notice.
  - C. Publication IPC-7351 is recommended for alternate design.
  - D. Laser cutting apertures with trapezoidal walls and also rounding corners will offer better paste release. Customers should contact their board assembly site for stencil design recommendations. Refer to IPC-7525 for other stencil recommendations.
  - E. Customers should contact their board fabrication site for solder mask tolerances between and around signal pads.

PW (R-PDSO-G28)

PLASTIC SMALL OUTLINE

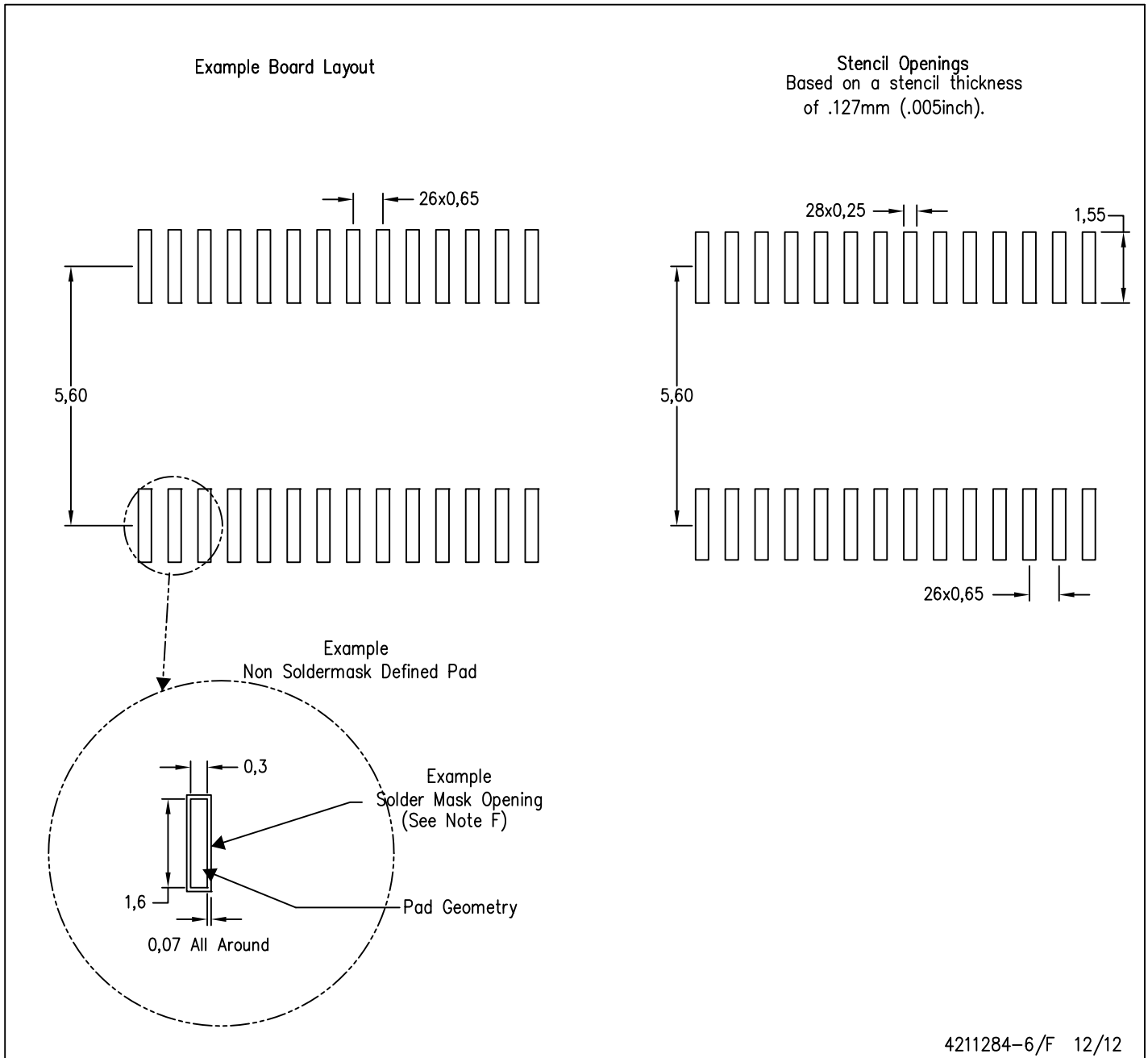

- NOTES:
- A. All linear dimensions are in millimeters.
  - B. This drawing is subject to change without notice.
  - C. Publication IPC-7351 is recommended for alternate design.
  - D. Laser cutting apertures with trapezoidal walls and also rounding corners will offer better paste release. Customers should contact their board assembly site for stencil design recommendations. Refer to IPC-7525 for other stencil recommendations.
  - E. Customers should contact their board fabrication site for solder mask tolerances between and around signal pads.

DB (R-PDSO-G\*\*)

PLASTIC SMALL-OUTLINE

28 PINS SHOWN



- NOTES: A. All linear dimensions are in millimeters.  
 B. This drawing is subject to change without notice.  
 C. Body dimensions do not include mold flash or protrusion not to exceed 0,15.  
 D. Falls within JEDEC MO-150

## IMPORTANT NOTICE

Texas Instruments Incorporated and its subsidiaries (TI) reserve the right to make corrections, enhancements, improvements and other changes to its semiconductor products and services per JESD46, latest issue, and to discontinue any product or service per JESD48, latest issue. Buyers should obtain the latest relevant information before placing orders and should verify that such information is current and complete. All semiconductor products (also referred to herein as "components") are sold subject to TI's terms and conditions of sale supplied at the time of order acknowledgment.

TI warrants performance of its components to the specifications applicable at the time of sale, in accordance with the warranty in TI's terms and conditions of sale of semiconductor products. Testing and other quality control techniques are used to the extent TI deems necessary to support this warranty. Except where mandated by applicable law, testing of all parameters of each component is not necessarily performed.

TI assumes no liability for applications assistance or the design of Buyers' products. Buyers are responsible for their products and applications using TI components. To minimize the risks associated with Buyers' products and applications, Buyers should provide adequate design and operating safeguards.

TI does not warrant or represent that any license, either express or implied, is granted under any patent right, copyright, mask work right, or other intellectual property right relating to any combination, machine, or process in which TI components or services are used. Information published by TI regarding third-party products or services does not constitute a license to use such products or services or a warranty or endorsement thereof. Use of such information may require a license from a third party under the patents or other intellectual property of the third party, or a license from TI under the patents or other intellectual property of TI.

Reproduction of significant portions of TI information in TI data books or data sheets is permissible only if reproduction is without alteration and is accompanied by all associated warranties, conditions, limitations, and notices. TI is not responsible or liable for such altered documentation. Information of third parties may be subject to additional restrictions.

Resale of TI components or services with statements different from or beyond the parameters stated by TI for that component or service voids all express and any implied warranties for the associated TI component or service and is an unfair and deceptive business practice. TI is not responsible or liable for any such statements.

Buyer acknowledges and agrees that it is solely responsible for compliance with all legal, regulatory and safety-related requirements concerning its products, and any use of TI components in its applications, notwithstanding any applications-related information or support that may be provided by TI. Buyer represents and agrees that it has all the necessary expertise to create and implement safeguards which anticipate dangerous consequences of failures, monitor failures and their consequences, lessen the likelihood of failures that might cause harm and take appropriate remedial actions. Buyer will fully indemnify TI and its representatives against any damages arising out of the use of any TI components in safety-critical applications.

In some cases, TI components may be promoted specifically to facilitate safety-related applications. With such components, TI's goal is to help enable customers to design and create their own end-product solutions that meet applicable functional safety standards and requirements. Nonetheless, such components are subject to these terms.

No TI components are authorized for use in FDA Class III (or similar life-critical medical equipment) unless authorized officers of the parties have executed a special agreement specifically governing such use.

Only those TI components which TI has specifically designated as military grade or "enhanced plastic" are designed and intended for use in military/aerospace applications or environments. Buyer acknowledges and agrees that any military or aerospace use of TI components which have **not** been so designated is solely at the Buyer's risk, and that Buyer is solely responsible for compliance with all legal and regulatory requirements in connection with such use.

TI has specifically designated certain components as meeting ISO/TS16949 requirements, mainly for automotive use. In any case of use of non-designated products, TI will not be responsible for any failure to meet ISO/TS16949.

### Products

Audio	<a href="http://www.ti.com/audio">www.ti.com/audio</a>
Amplifiers	<a href="http://amplifier.ti.com">amplifier.ti.com</a>
Data Converters	<a href="http://dataconverter.ti.com">dataconverter.ti.com</a>
DLP® Products	<a href="http://www.dlp.com">www.dlp.com</a>
DSP	<a href="http://dsp.ti.com">dsp.ti.com</a>
Clocks and Timers	<a href="http://www.ti.com/clocks">www.ti.com/clocks</a>
Interface	<a href="http://interface.ti.com">interface.ti.com</a>
Logic	<a href="http://logic.ti.com">logic.ti.com</a>
Power Mgmt	<a href="http://power.ti.com">power.ti.com</a>
Microcontrollers	<a href="http://microcontroller.ti.com">microcontroller.ti.com</a>
RFID	<a href="http://www.ti-rfid.com">www.ti-rfid.com</a>
OMAP Applications Processors	<a href="http://www.ti.com/omap">www.ti.com/omap</a>
Wireless Connectivity	<a href="http://www.ti.com/wirelessconnectivity">www.ti.com/wirelessconnectivity</a>

### Applications

Automotive and Transportation	<a href="http://www.ti.com/automotive">www.ti.com/automotive</a>
Communications and Telecom	<a href="http://www.ti.com/communications">www.ti.com/communications</a>
Computers and Peripherals	<a href="http://www.ti.com/computers">www.ti.com/computers</a>
Consumer Electronics	<a href="http://www.ti.com/consumer-apps">www.ti.com/consumer-apps</a>
Energy and Lighting	<a href="http://www.ti.com/energy">www.ti.com/energy</a>
Industrial	<a href="http://www.ti.com/industrial">www.ti.com/industrial</a>
Medical	<a href="http://www.ti.com/medical">www.ti.com/medical</a>
Security	<a href="http://www.ti.com/security">www.ti.com/security</a>
Space, Avionics and Defense	<a href="http://www.ti.com/space-avionics-defense">www.ti.com/space-avionics-defense</a>
Video and Imaging	<a href="http://www.ti.com/video">www.ti.com/video</a>

### TI E2E Community

[e2e.ti.com](http://e2e.ti.com)