

Description

The MAX4597 is a single-pole single-throw (SPST) analog switch that is designed to operate from 2 V to 5.5 V. This device can handle both digital and analog signals, and signals up to V_+ can be transmitted in either direction.

Applications

- Sample-and-Hold Circuits
- Battery-Powered Equipment (Cellular Phones, PDAs)
- Audio and Video Signal Routing
- Communication Circuits
- PCMCIA Cards

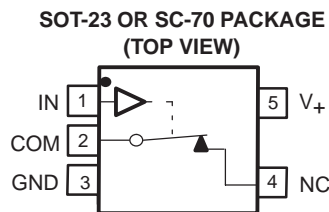

FUNCTION TABLE

IN	NC TO COM, COM TO NC
L	ON
H	OFF

Features

- Low ON-State Resistance (10 Ω)
- ON-State Resistance Flatness (1.5 Ω)
- Control Inputs Are 5.5-V Tolerant
- Low Charge Injection (5 pC Max)
- 300-MHz –3-dB Bandwidth at 25°C
- Low Total Harmonic Distortion (THD) (0.05%)
- 2-V to 5.5-V Single-Supply Operation
- Specified at 5-V and 3.3-V Nodes
- –83-dB OFF Isolation at 1 MHz
- Latch-Up Performance Exceeds 100 mA Per JESD 78, Class II
- 0.5-nA Max OFF Leakage
- ESD Performance Tested Per JESD 22
 - 2000-V Human-Body Model (A114-B, Class II)
 - 1000-V Charged-Device Model (C101)
- TTL/CMOS-Logic Compatible

Summary of Characteristics

$V_+ = 5\text{ V}$, $T_A = 25^\circ\text{C}$

Configuration	Single Pole Single Throw (SPST)
Number of channels	1
ON-state resistance (r_{ON})	10 Ω
ON-state resistance flatness ($r_{ON(FLAT)}$)	1.5 Ω
Turn-on/turn-off time (t_{ON}/t_{OFF})	35 ns/40 ns
Charge injection (Q_C)	5 pC
Bandwidth (BW)	300 MHz
OFF isolation (O_{ISO})	–83 dB at 1 MHz
Total harmonic distortion (THD)	0.05%
Leakage current ($I_{COM(OFF)}/I_{NC(OFF)}$)	±0.05 nA
Power-supply current (I_+)	1 μA
Package option	5-pin SOT-23 or SC-70

ORDERING INFORMATION

T_A	PACKAGE(1)		ORDERABLE PART NUMBER	TOP-SIDE MARKING(2)
–40°C to 85°C	SOT (SOT-23) – DBV	Tape and reel	MAX4597DBVR	6SD_
	SOT (SC-70) – DCK	Tape and reel	MAX4597DCKR	SD_

(1) Package drawings, standard packing quantities, thermal data, symbolization, and PCB design guidelines are available at www.ti.com/sc/package.
(2) DBV/DCK: The actual top-side marking has one additional character that designates the assembly/test site.



Please be aware that an important notice concerning availability, standard warranty, and use in critical applications of Texas Instruments semiconductor products and disclaimers thereto appears at the end of this data sheet.

Pin Configurations

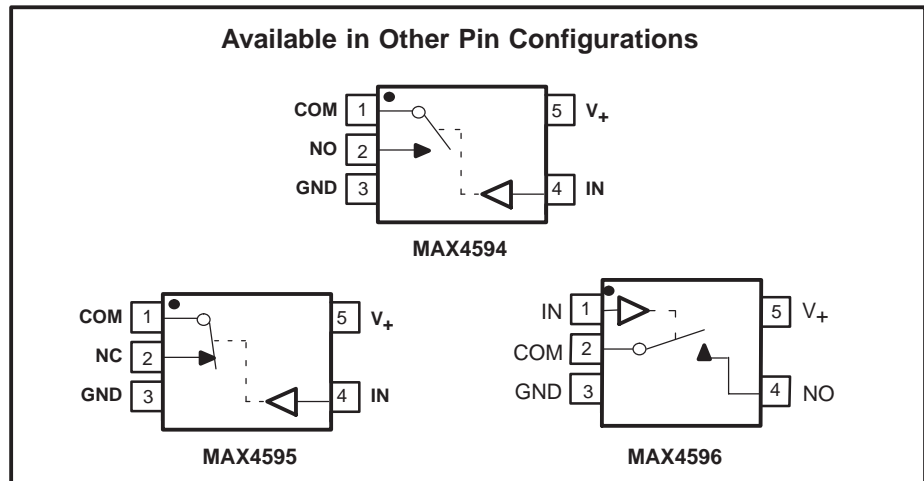
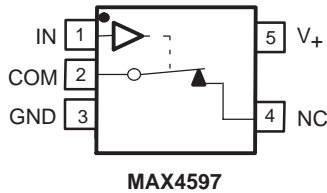

Absolute Minimum and Maximum Ratings(1)(2)

over operating free-air temperature range (unless otherwise noted)

		MIN	MAX	UNIT
V_+	Supply voltage range(3)	-0.3	6	V
V_{NC} V_{COM}	Analog voltage range(3)(4)	-0.3	$V_+ + 0.3$	V
I_K	Analog port diode current	$V_{NC}, V_{COM} < 0$		mA
I_{NC} I_{COM}	On-state switch current	$V_{NC}, V_{COM} = 0$ to V_+		mA
V_I	Digital input voltage range(3)(4)	-0.3	6	V
I_{IK}	Digital input clamp current	$V_I < 0$		mA
I_+	Continuous current through V_+		100	mA
I_{GND}	Continuous current through GND	-100		mA
θ_{JA}	Package thermal impedance(5)	DBV package		206
		DCK package		252
T_{stg}	Storage temperature range	-65	150	°C

(1) Stresses above these ratings may cause permanent damage. Exposure to absolute maximum conditions for extended periods may degrade device reliability. These are stress ratings only, and functional operation of the device at these or any other conditions beyond those specified is not implied.

(2) The algebraic convention, whereby the most negative value is a minimum and the most positive value is a maximum

(3) All voltages are with respect to ground, unless otherwise specified.

(4) The input and output voltage ratings may be exceeded if the input and output clamp-current ratings are observed.

(5) The package thermal impedance is calculated in accordance with JESD 51-7.

Electrical Characteristics for 5-V Supply⁽¹⁾

$V_+ = 4.5\text{ V to }5.5\text{ V}$, $T_A = -40^\circ\text{C to }85^\circ\text{C}$ (unless otherwise noted)

PARAMETER	SYMBOL	TEST CONDITIONS	T_A	V_+	MIN	TYP	MAX	UNIT
Analog Switch								
Analog signal range	V_{COM}, V_{NC}				0		V_+	V
ON-state resistance	r_{on}	$V_{NC} = 3.5\text{ V}$, $I_{COM} = 10\text{ mA}$,	Switch ON, See Figure 13	25°C Full	4.5 V	6.5	10 12	Ω
ON-state resistance flatness	$r_{on(Flat)}$	$V_{NC} = 1.5\text{ V}, 2.5\text{ V}, 3.5\text{ V}$, $I_{COM} = 10\text{ mA}$,	Switch ON, See Figure 13	25°C Full	4.5 V	0.5	1.5 2	Ω
NC OFF leakage current	$I_{NC(OFF)}$	$V_{NC} = 1\text{ V}, V_{COM} = 4.5\text{ V}$, or $V_{NC} = 4.5\text{ V}, V_{COM} = 1\text{ V}$,	Switch OFF, See Figure 14	25°C Full	5.5 V	-0.5	0.01 0.5	nA
COM OFF leakage current	$I_{COM(OFF)}$	$V_{COM} = 1\text{ V}, V_{NC} = 4.5\text{ V}$, or $V_{COM} = 4.5\text{ V}, V_{NC} = 1\text{ V}$,	Switch OFF, See Figure 14	25°C Full	5.5 V	-0.5	0.01 0.5	nA
NC ON leakage current	$I_{NC(ON)}$	$V_{NC} = 1\text{ V}, V_{COM} = 1\text{ V}$, or $V_{NC} = 4.5\text{ V}, V_{COM} = 4.5\text{ V}$, or $V_{NC} = 1\text{ V}, 4.5\text{ V}, V_{COM} = \text{Open}$,	Switch ON, See Figure 15	25°C Full	5.5 V	-1	0.01 10	nA
COM ON leakage current	$I_{COM(ON)}$	$V_{COM} = 1\text{ V}, V_{NC} = 1\text{ V}$, or $V_{COM} = 4.5\text{ V}, V_{NC} = 4.5\text{ V}$, or $V_{COM} = 1\text{ V}, 4.5\text{ V}, V_{NC} = \text{Open}$,	Switch ON, See Figure 15	25°C Full	5.5 V	-1	0.01 10	nA
Digital Control Input (IN)								
Input logic high	V_{IH}			Full		2.4	5.5	V
Input logic low	V_{IL}			Full		0	0.8	V
Input leakage current	I_{IH}, I_{IL}	$V_I = 5.5\text{ V or }0$		25°C Full	5.5 V	-1	0.03 1	μA

(1) The algebraic convention, whereby the most negative value is a minimum and the most positive value is a maximum

MAX4597

SINGLE-CHANNEL 10-Ω SPST ANALOG SWITCH

SLLS642 – JANUARY 2005

Electrical Characteristics for 5-V Supply⁽¹⁾ (continued)

V_+ = 4.5 V to 5.5 V, T_A = -40°C to 85°C (unless otherwise noted)

PARAMETER	SYMBOL	TEST CONDITIONS	T_A	V_+	MIN	TYP	MAX	UNIT
Dynamic								
Turn-on time	t_{ON}	$V_{NC} = 3\text{ V}$, $R_L = 300\ \Omega$,	$C_L = 35\text{ pF}$, See Figure 17	25°C	5 V	20	35	ns
				Full	4.5 V to 5.5 V		45	
Turn-off time	t_{OFF}	$V_{NC} = 3\text{ V}$, $R_L = 300\ \Omega$,	$C_L = 35\text{ pF}$, See Figure 17	25°C	5 V	25	40	ns
				Full	4.5 V to 5.5 V		50	
Charge injection	Q_C	$V_{GEN} = 0$, $R_{GEN} = 0$,	$C_L = 1\text{ nF}$, See Figure 20	25°C	5 V	2	5	pC
NC OFF capacitance	C_{NCOFF}	$V_{NC} = 0$, $f = 1\text{ MHz}$,	Switch OFF, See Figure 16	25°C	5 V	8		pF
COM OFF capacitance	C_{COMOFF}	$V_{COM} = 0$, $f = 1\text{ MHz}$,	Switch OFF, See Figure 16	25°C	5 V	8		pF
NC ON capacitance	C_{NCON}	$V_{NC} = 0$, $f = 1\text{ MHz}$,	Switch ON, See Figure 16	25°C	5 V	20		pF
COM ON capacitance	C_{COMON}	$V_{COM} = 0$, $f = 1\text{ MHz}$,	Switch ON, See Figure 16	25°C	5 V	20		pF
Digital input capacitance	C_I	$V_I = V_+$ or GND,	See Figure 16	25°C	5 V	3		pF
Bandwidth	BW	$R_L = 50\ \Omega$, Signal = 0 dBm,	Switch ON, See Figure 18	25°C	5 V	300		MHz
OFF isolation	O_{ISO}	$R_L = 50\ \Omega$, $f = 10\text{ MHz}$, $V_{NC} = 1\text{ V}_{RMS}$,	Switch OFF, See Figure 19	25°C	5 V	-83		dB
Total harmonic distortion	THD	$R_L = 600\ \Omega$, $C_L = 50\text{ pF}$, $V_{SOURCE} = 5\text{ V}_{p-p}$,	$f = 20\text{ Hz}$ to 20 kHz, See Figure 21	25°C	5 V	0.05		%
Supply								
Positive supply current	I_+	$V_I = V_+$ or GND,	Switch ON or OFF	Full	5.5 V		1	μA

(1) The algebraic convention, whereby the most negative value is a minimum and the most positive value is a maximum

Electrical Characteristics for 3-V Supply⁽¹⁾
 $V_+ = 2.7\text{ V to }3.6\text{ V}$, $T_A = -40^\circ\text{C to }85^\circ\text{C}$ (unless otherwise noted)

PARAMETER	SYMBOL	TEST CONDITIONS	T_A	V_+	MIN	TYP	MAX	UNIT
Analog Switch								
Analog signal range	V_{COM} , V_{NC}				0		V_+	V
ON-state resistance	r_{on}	$V_{NC} = 1.5\text{ V}$, $I_{COM} = 10\text{ mA}$,	Switch ON, See Figure 13	25°C Full	2.7 V	10	20 25	Ω
Digital Control Input (IN)								
Input logic high	V_{IH}			Full		2	5.5	V
Input logic low	V_{IL}			Full		0	0.8	V
Input leakage current	I_{IH} , I_{IL}	$V_I = V_+$ or 0		25°C Full	3.6 V	-1	0.03 1	μA
Dynamic								
Turn-on time	t_{ON}	$V_{COM} = 2\text{ V}$, $R_L = 300\text{ Ω}$,	$C_L = 35\text{ pF}$, See Figure 17	25°C Full	3 V 2.7 V to 3.6 V	25	45 55	ns
Turn-off time	t_{OFF}	$V_{COM} = 2\text{ V}$, $R_L = 300\text{ Ω}$,	$C_L = 35\text{ pF}$, See Figure 17	25°C Full	3 V 2.7 V to 3.6 V	30	50 60	ns
Charge injection	Q_C	$V_{NC} = 0$, $C_L = 1\text{ nF}$,	See Figure 20	25°C	3 V	2	4	pC
Supply								
Positive supply current	I_+	$V_I = V_+$ or GND,	Switch ON or OFF	Full	3.6 V		1	μA

⁽¹⁾ The algebraic convention, whereby the most negative value is a minimum and the most positive value is a maximum

TYPICAL PERFORMANCE

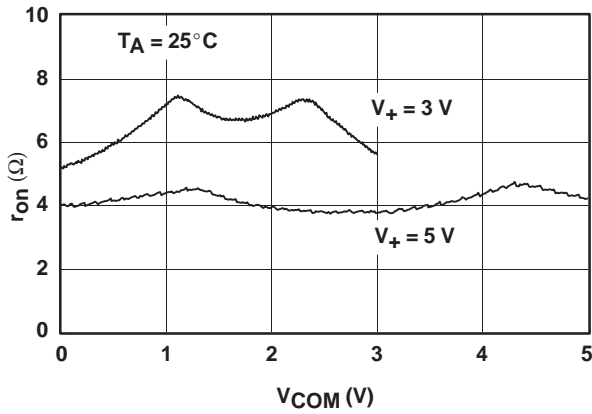

Figure 1. r_{on} vs V_{COM}

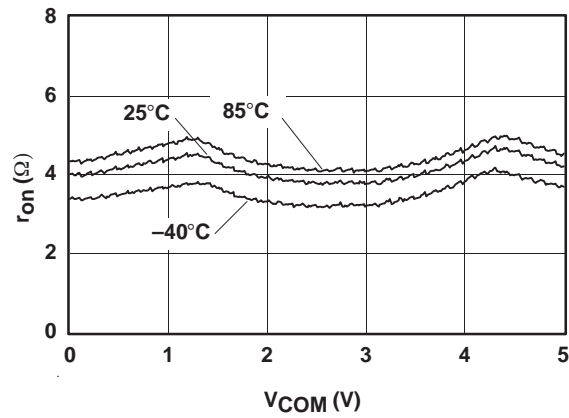

Figure 2. r_{on} vs V_{COM} ($V_+ = 5V$)

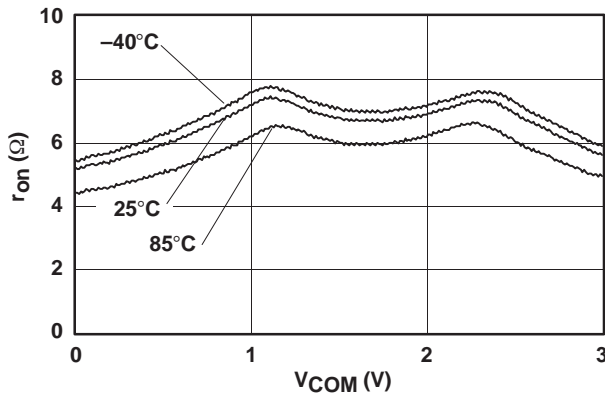

Figure 3. r_{on} vs V_{COM} ($V_+ = 3V$)

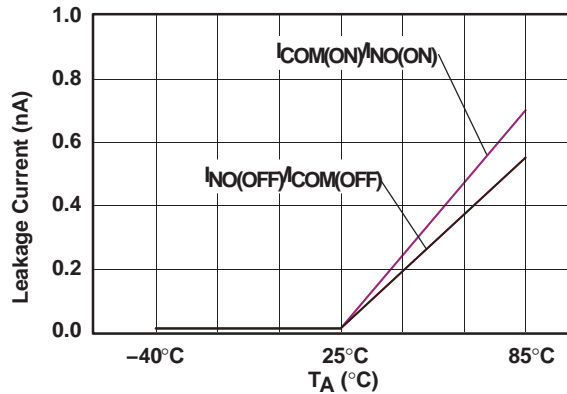

Figure 4. Leakage Current vs Temperature ($V_+ = 5V$)

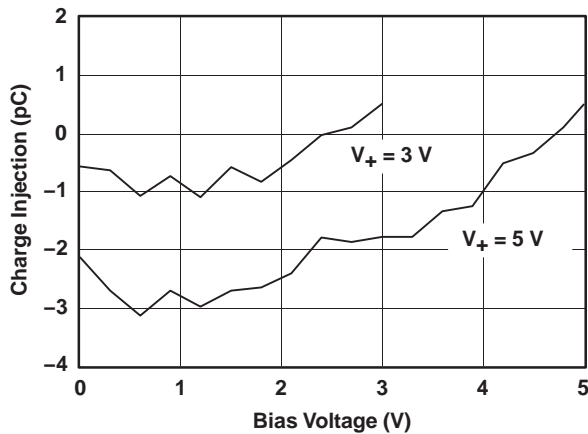

Figure 5. Charge-Injection (Q_C) vs V_{COM}

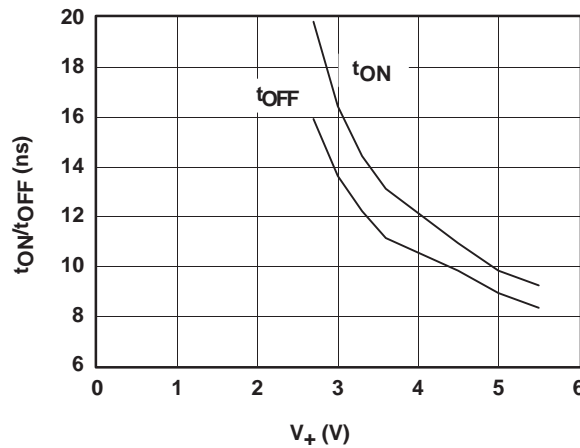

Figure 6. t_{ON} and t_{OFF} vs Supply Voltage

TYPICAL PERFORMANCE

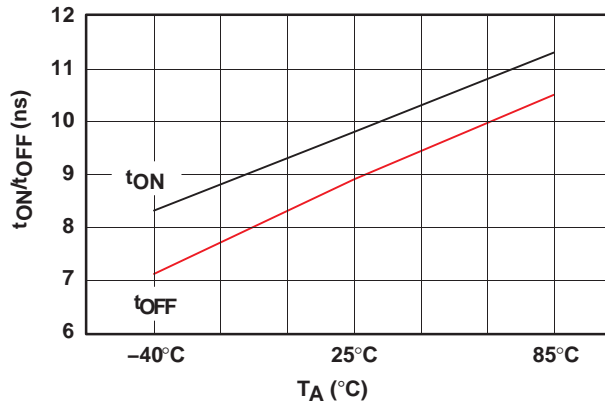

Figure 7. t_{ON} and t_{OFF} vs Temperature ($V_+ = 5\text{ V}$)

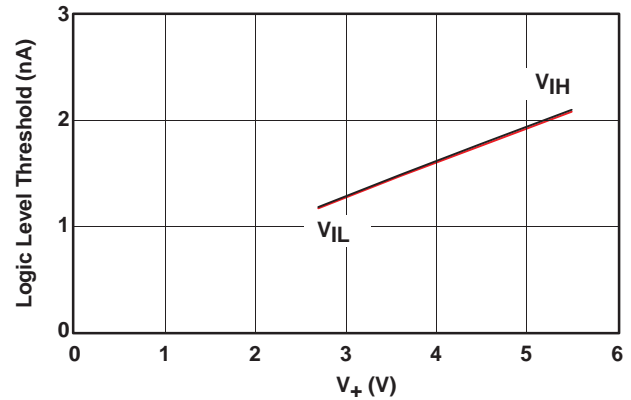

Figure 8. Logic-Level Threshold vs V_+

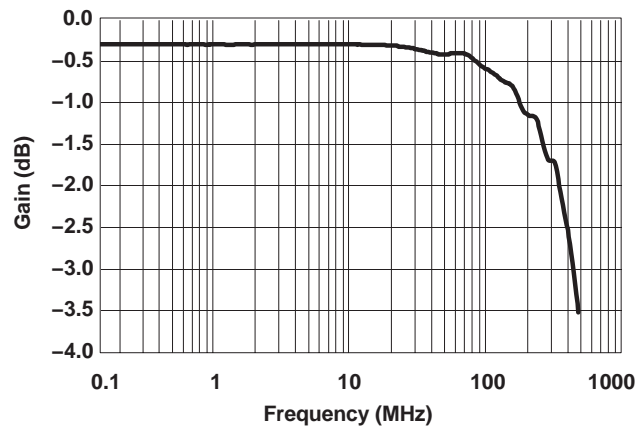

Figure 9. Bandwidth (Gain vs Frequency) ($V_+ = 5\text{ V}$)

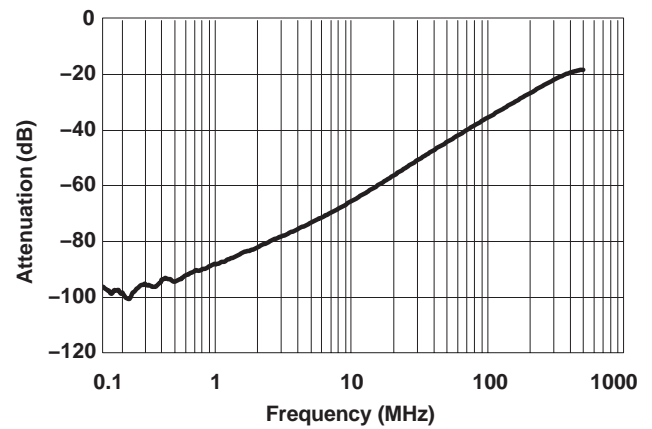

Figure 10. Off Isolation vs Frequency

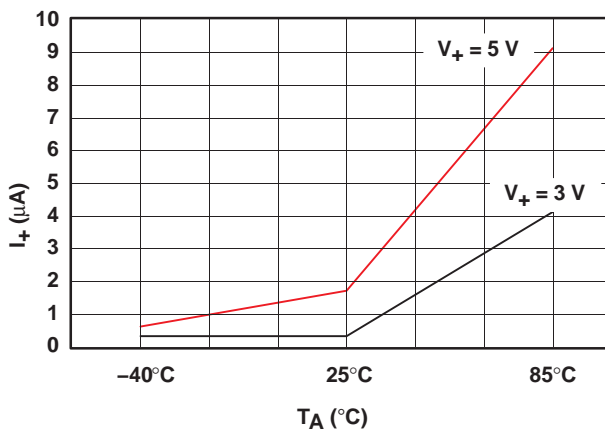

Figure 11. Power-Supply Current vs Temperature

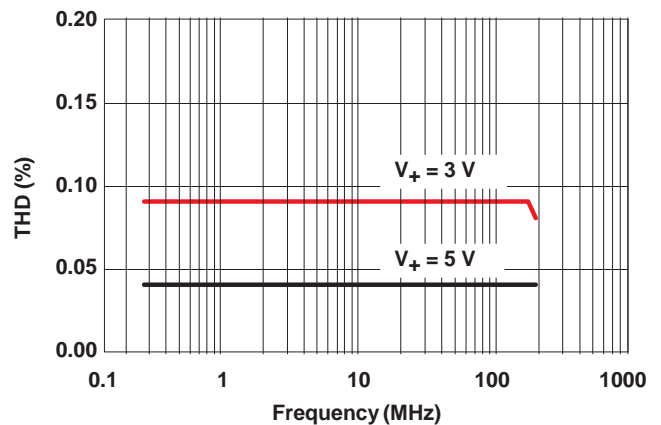

Figure 12. Total Harmonic Distortion vs Frequency

PIN DESCRIPTION

PIN NUMBER	NAME	DESCRIPTION
1	IN	Digital control pin to connect COM to NC
2	COM	Common
3	GND	Digital ground
4	NC	Normally closed
5	V ₊	Power supply

PARAMETER DESCRIPTION

SYMBOL	DESCRIPTION
V _{COM}	Voltage at COM
V _{NC}	Voltage at NC
r _{on}	Resistance between COM and NC ports when the channel is ON
r _{on(flat)}	Difference between the maximum and minimum value of r _{on} in a channel over the specified range of conditions
I _{NC(OFF)}	Leakage current measured at the NC port, with the corresponding channel (NC to COM) in the OFF state
I _{NC(ON)}	Leakage current measured at the NC port, with the corresponding channel (NC to COM) in the ON state and the output (COM) open
I _{COM(OFF)}	Leakage current measured at the COM port, with the corresponding channel (COM to NC) in the OFF state
I _{COM(ON)}	Leakage current measured at the COM port, with the corresponding channel (COM to NC) in the ON state and the output (NC) open
V _{IH}	Minimum input voltage for logic high for the control input (IN)
V _{IL}	Maximum input voltage for logic low for the control input (IN)
V _I	Voltage at the control input (IN)
I _{IH} , I _{IL}	Leakage current measured at the control input (IN)
t _{ON}	Turn-on time for the switch. This parameter is measured under the specified range of conditions and by the propagation delay between the digital control (IN) signal and analog output (COM or NC) signal when the switch is turning ON.
t _{OFF}	Turn-off time for the switch. This parameter is measured under the specified range of conditions and by the propagation delay between the digital control (IN) signal and analog output (COM or NC) signal when the switch is turning OFF.
Q _C	Charge injection is a measurement of unwanted signal coupling from the control (IN) input to the analog (NC or COM) output. This is measured in coulomb (C) and measured by the total charge induced due to switching of the control input. Charge injection, Q _C = C _L × ΔV _{COM} , C _L is the load capacitance, and ΔV _{COM} is the change in analog output voltage.
C _{NC(OFF)}	Capacitance at the NC port when the corresponding channel (NC to COM) is OFF
C _{NC(ON)}	Capacitance at the NC port when the corresponding channel (NC to COM) is ON
C _{COM(OFF)}	Capacitance at the COM port when the corresponding channel (COM to NC) is OFF
C _{COM(ON)}	Capacitance at the COM port when the corresponding channel (COM to NC) is ON
C _I	Capacitance of control input (IN)
O _{ISO}	OFF isolation of the switch is a measurement of OFF-state switch impedance. This is measured in dB in a specific frequency, with the corresponding channel (NC to COM) in the OFF state.
BW	Bandwidth of the switch. This is the frequency in which the gain of an ON channel is –3 dB below the DC gain.
THD	Total harmonic distortion describes the signal distortion caused by the analog switch. This is defined as the ratio of root mean square (RMS) value of the second, third, and higher harmonic to the absolute magnitude of the fundamental harmonic.
I ₊	Static power-supply current with the control (IN) pin at V ₊ or GND

PARAMETER MEASUREMENT INFORMATION

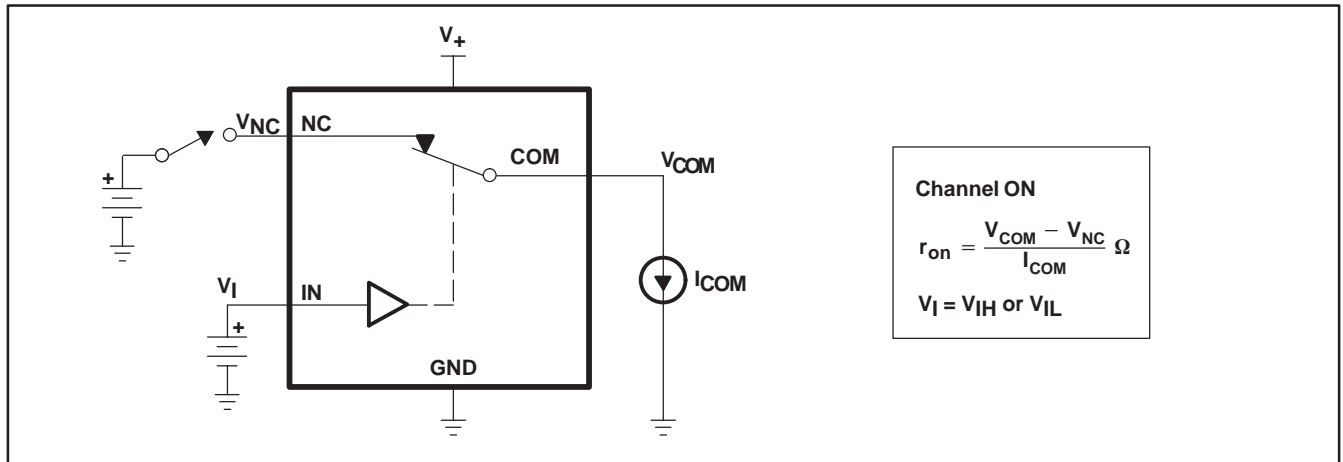

Figure 13. ON-State Resistance (r_{on})

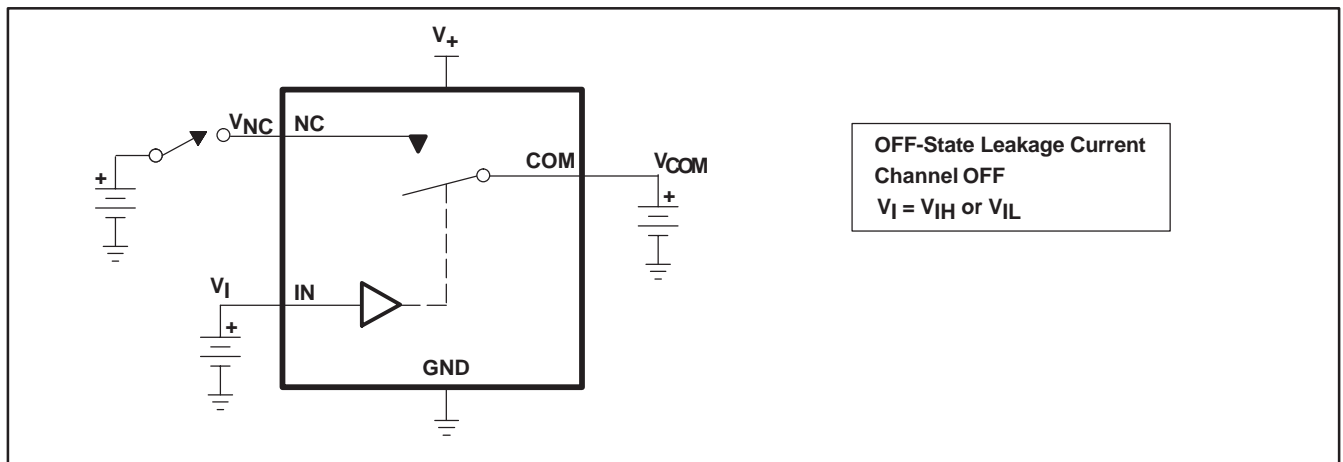

Figure 14. OFF-State Leakage Current ($I_{COM(OFF)}$, $I_{NC(OFF)}$)

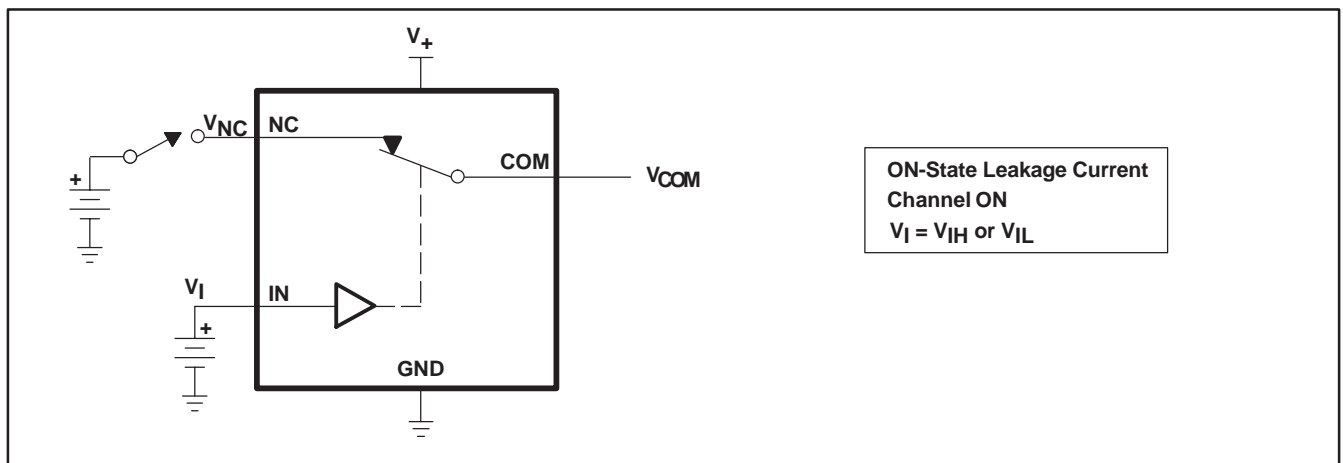

Figure 15. ON-State Leakage Current ($I_{COM(ON)}$, $I_{NC(ON)}$)

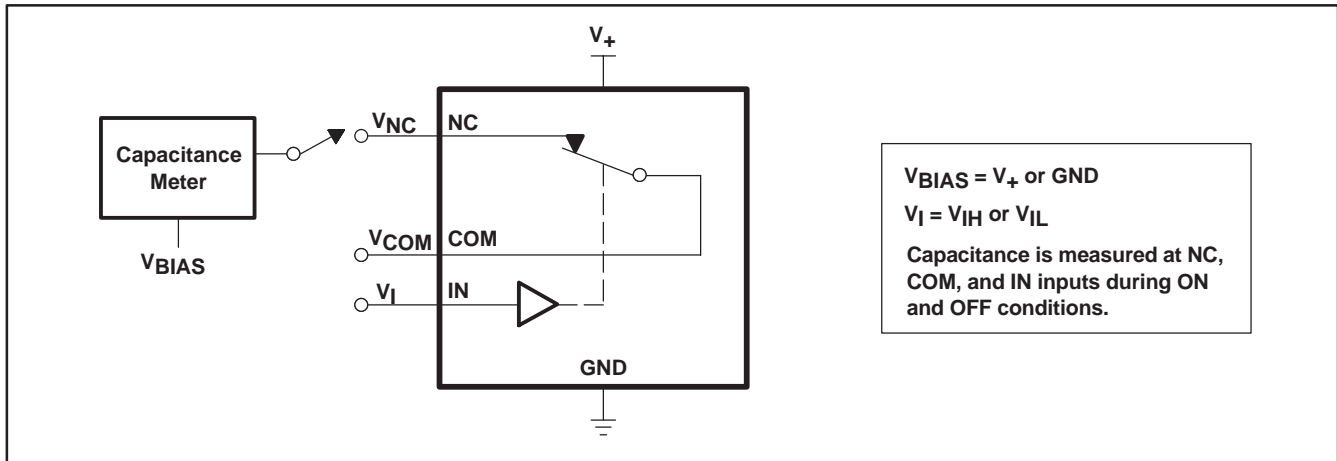
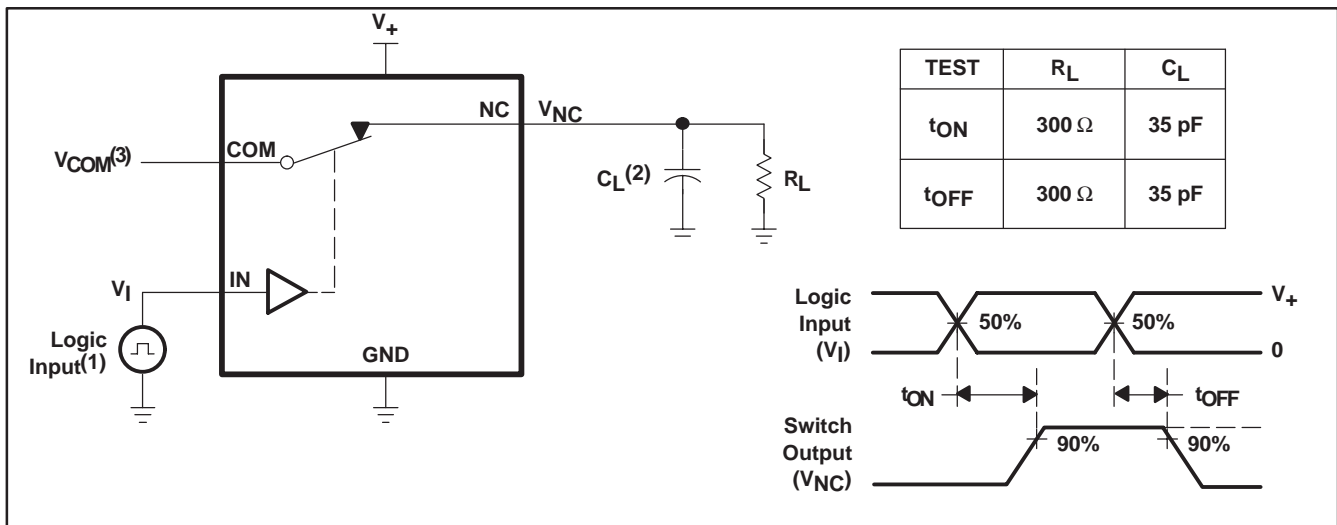

Figure 16. Capacitance (C_I , $C_{COM(OFF)}$, $C_{COM(ON)}$, $C_{NC(OFF)}$, $C_{NC(ON)}$)



- (1) All input pulses are supplied by generators having the following characteristics: PRR \leq 10 MHz, $Z_O = 50 \Omega$, $t_r < 5$ ns, $t_f < 5$ ns.
- (2) C_L includes probe and jig capacitance.
- (3) See Electrical Characteristics for V_{COM} .

Figure 17. Turn-On (t_{ON}) and Turn-Off Time (t_{OFF})

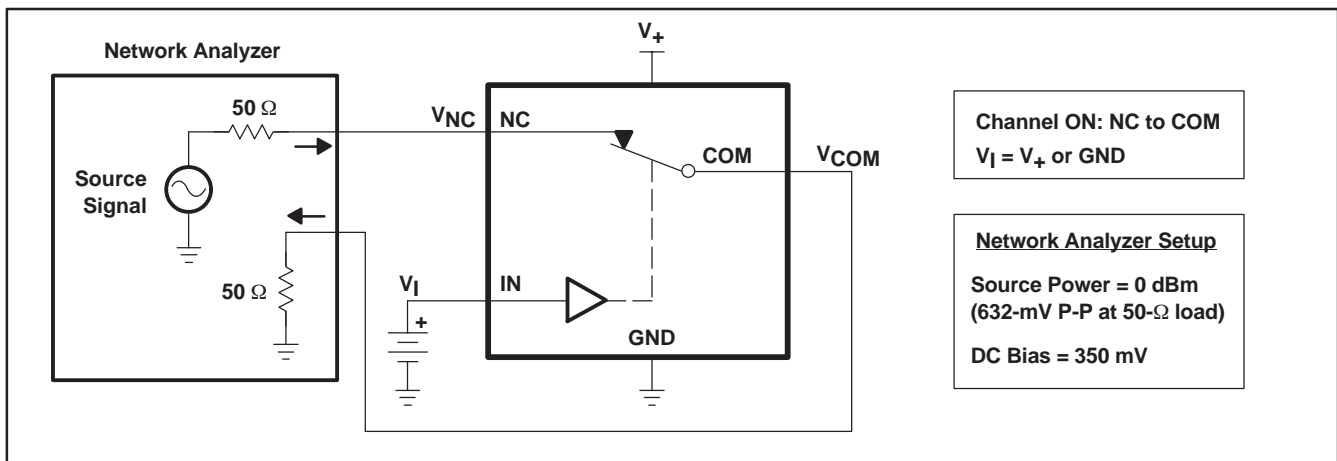

Figure 18. Bandwidth (BW)

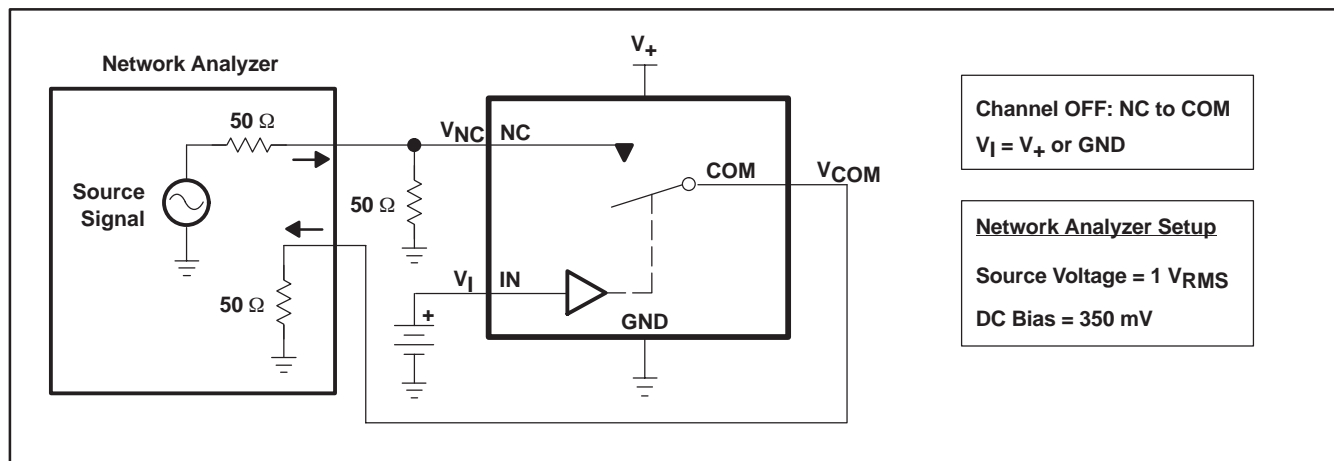
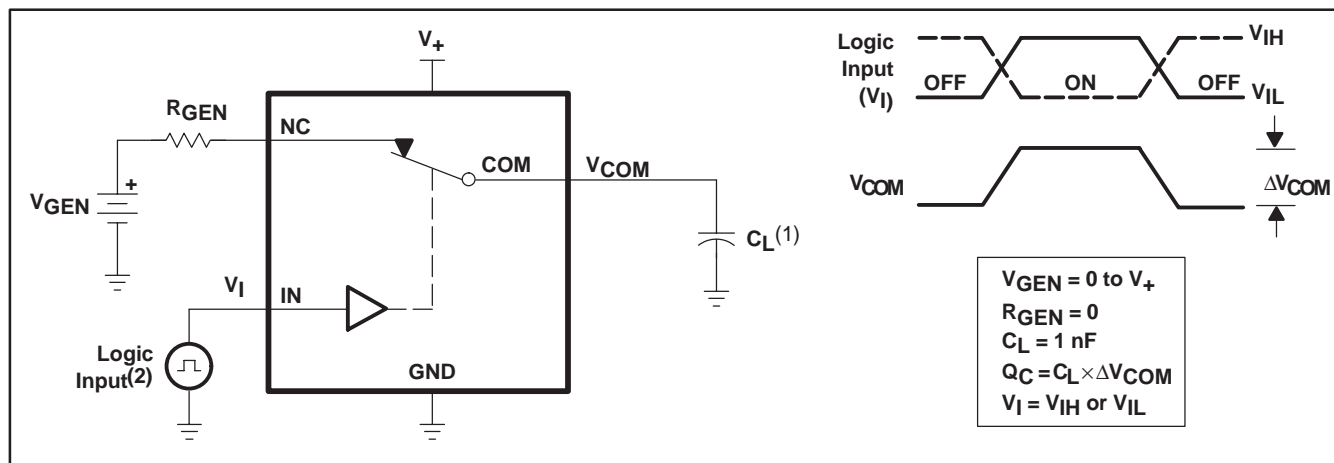

Figure 19. OFF Isolation (O_{ISO})



(1) C_L includes probe and jig capacitance.

(2) All input pulses are supplied by generators having the following characteristics: $PRR \leq 10$ MHz, $Z_O = 50 \Omega$, $t_r < 5$ ns, $t_f < 5$ ns.

Figure 20. Charge Injection (Q_C)

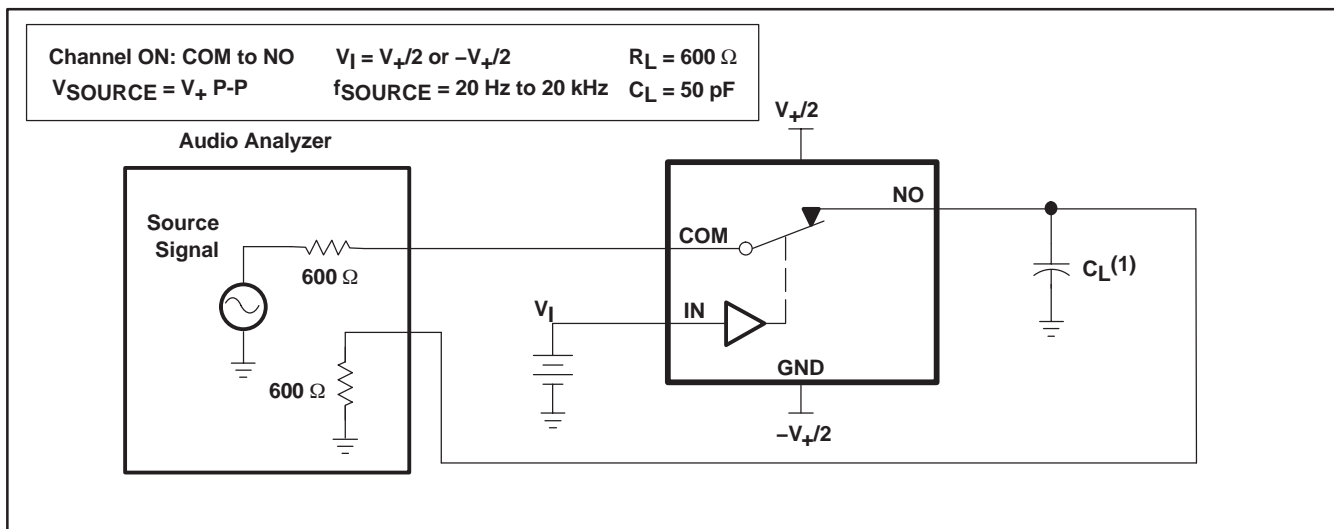

(1) C_L includes probe and jig capacitance.

Figure 21. Total Harmonic Distortion (THD)

DBV (R-PDSO-G5)

PLASTIC SMALL-OUTLINE PACKAGE

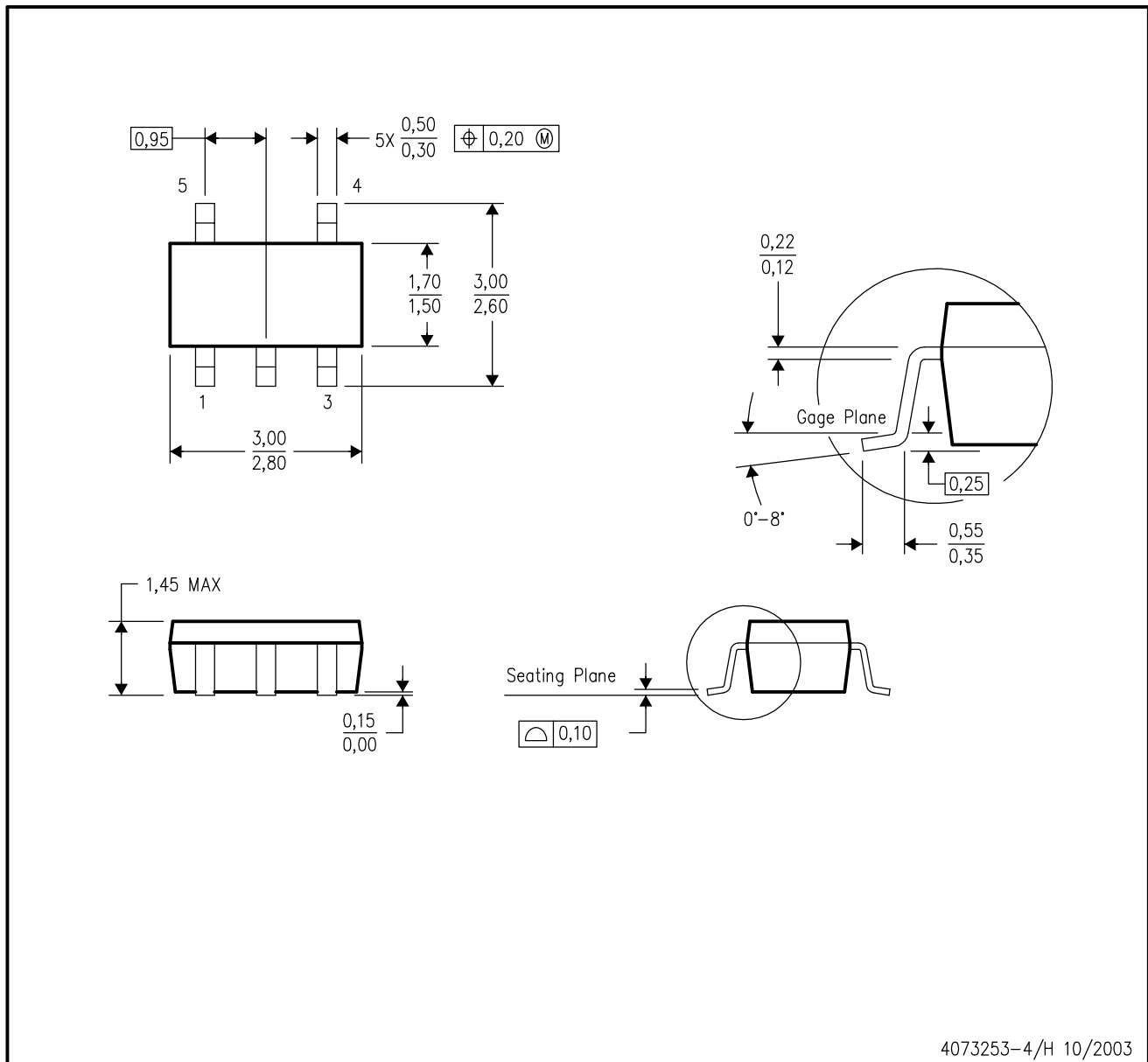

4073253-4/H 10/2003

- NOTES:
- A. All linear dimensions are in millimeters.
 - B. This drawing is subject to change without notice.
 - C. Body dimensions do not include mold flash or protrusion.
 - D. Falls within JEDEC MO-178 Variation AA.

DCK (R-PDSO-G5)

PLASTIC SMALL-OUTLINE PACKAGE

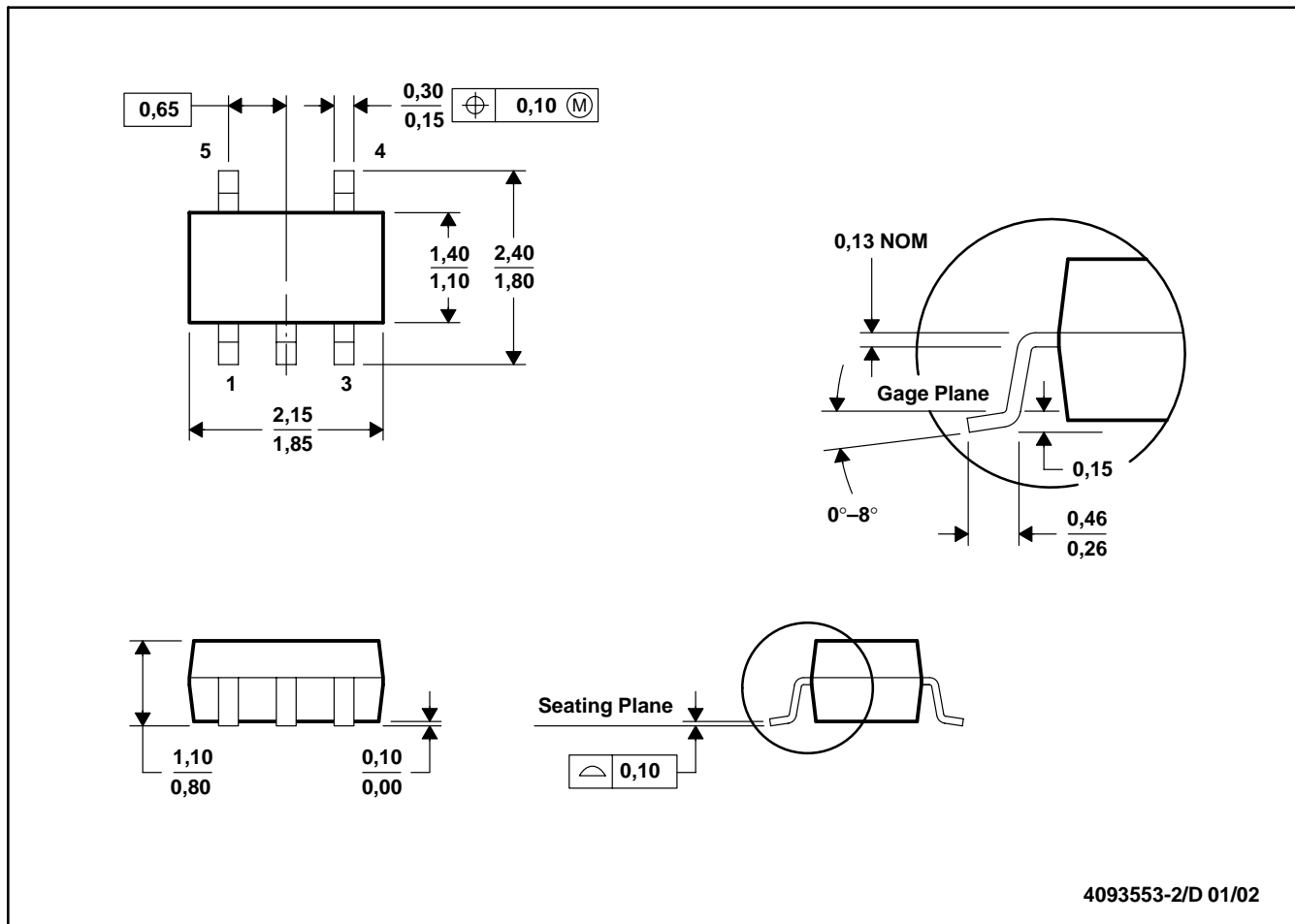

- NOTES: A. All linear dimensions are in millimeters.
 B. This drawing is subject to change without notice.
 C. Body dimensions do not include mold flash or protrusion.
 D. Falls within JEDEC MO-203

IMPORTANT NOTICE

Texas Instruments Incorporated and its subsidiaries (TI) reserve the right to make corrections, modifications, enhancements, improvements, and other changes to its products and services at any time and to discontinue any product or service without notice. Customers should obtain the latest relevant information before placing orders and should verify that such information is current and complete. All products are sold subject to TI's terms and conditions of sale supplied at the time of order acknowledgment.

TI warrants performance of its hardware products to the specifications applicable at the time of sale in accordance with TI's standard warranty. Testing and other quality control techniques are used to the extent TI deems necessary to support this warranty. Except where mandated by government requirements, testing of all parameters of each product is not necessarily performed.

TI assumes no liability for applications assistance or customer product design. Customers are responsible for their products and applications using TI components. To minimize the risks associated with customer products and applications, customers should provide adequate design and operating safeguards.

TI does not warrant or represent that any license, either express or implied, is granted under any TI patent right, copyright, mask work right, or other TI intellectual property right relating to any combination, machine, or process in which TI products or services are used. Information published by TI regarding third-party products or services does not constitute a license from TI to use such products or services or a warranty or endorsement thereof. Use of such information may require a license from a third party under the patents or other intellectual property of the third party, or a license from TI under the patents or other intellectual property of TI.

Reproduction of information in TI data books or data sheets is permissible only if reproduction is without alteration and is accompanied by all associated warranties, conditions, limitations, and notices. Reproduction of this information with alteration is an unfair and deceptive business practice. TI is not responsible or liable for such altered documentation.

Resale of TI products or services with statements different from or beyond the parameters stated by TI for that product or service voids all express and any implied warranties for the associated TI product or service and is an unfair and deceptive business practice. TI is not responsible or liable for any such statements.

Following are URLs where you can obtain information on other Texas Instruments products and application solutions:

Products		Applications	
Amplifiers	amplifier.ti.com	Audio	www.ti.com/audio
Data Converters	dataconverter.ti.com	Automotive	www.ti.com/automotive
DSP	dsp.ti.com	Broadband	www.ti.com/broadband
Interface	interface.ti.com	Digital Control	www.ti.com/digitalcontrol
Logic	logic.ti.com	Military	www.ti.com/military
Power Mgmt	power.ti.com	Optical Networking	www.ti.com/opticalnetwork
Microcontrollers	microcontroller.ti.com	Security	www.ti.com/security
		Telephony	www.ti.com/telephony
		Video & Imaging	www.ti.com/video
		Wireless	www.ti.com/wireless

Mailing Address: Texas Instruments
Post Office Box 655303 Dallas, Texas 75265