

# Wide Bandwidth PRECISION ANALOG MULTIPLIER

## FEATURES

- WIDE BANDWIDTH: 10MHz typ
- ±0.5% MAX FOUR-QUADRANT ACCURACY
- INTERNAL WIDE-BANDWIDTH OP AMP
- EASY TO USE
- LOW COST

## APPLICATIONS

- PRECISION ANALOG SIGNAL PROCESSING
- MODULATION AND DEMODULATION
- VOLTAGE-CONTROLLED AMPLIFIERS
- VIDEO SIGNAL PROCESSING
- VOLTAGE-CONTROLLED FILTERS AND OSCILLATORS

## DESCRIPTION

The MPY634 is a wide bandwidth, high accuracy, four-quadrant analog multiplier. Its accurately laser-trimmed multiplier characteristics make it easy to use in a wide variety of applications with a minimum of external parts, often eliminating all external trimming. Its differential X, Y, and Z inputs allow configuration as a multiplier, squarer, divider, square-rooter, and other functions while maintaining high accuracy.

The wide bandwidth of this new design allows signal processing at IF, RF, and video frequencies. The internal output amplifier of the MPY634 reduces design complexity compared to other high frequency multipliers and balanced modulator circuits. It is capable of performing frequency mixing, balanced modulation, and demodulation with excellent carrier rejection.

An accurate internal voltage reference provides precise setting of the scale factor. The differential Z input allows user-selected scale factors from 0.1 to 10 using external feedback resistors.

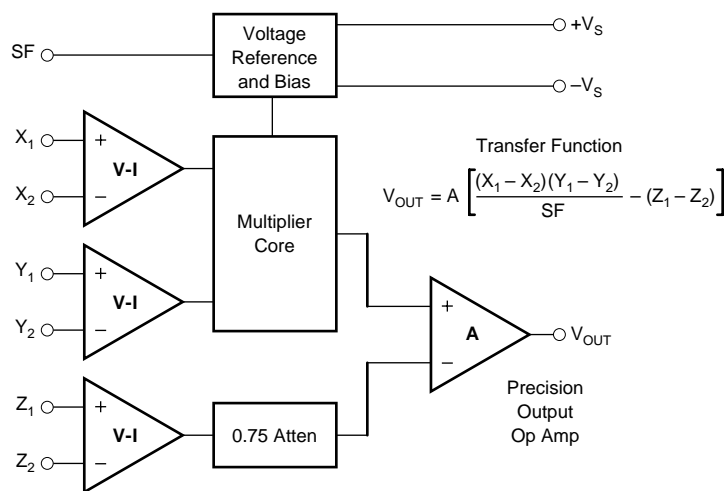

Please be aware that an important notice concerning availability, standard warranty, and use in critical applications of Texas Instruments semiconductor products and disclaimers thereto appears at the end of this data sheet.

All trademarks are the property of their respective owners.

# SPECIFICATIONS

## ELECTRICAL

At  $T_A = +25^\circ\text{C}$  and  $V_S = \pm 15\text{VDC}$ , unless otherwise noted.

MODEL	MPY634KP/KU			MPY634AM <b>OBSOLETE</b>			MPY634BM <b>OBSOLETE</b>			MPY634SM <b>OBSOLETE</b>			UNITS
	MIN	TYP	MAX	MIN	TYP	MAX	MIN	TYP	MAX	MIN	TYP	MAX	
<b>MULTIPLIER PERFORMANCE</b>	$\frac{(X_1 - X_2)(Y_1 - Y_2)}{10V} + Z_2$			$\frac{(X_1 - X_2)(Y_1 - Y_2)}{10V} + Z_2$									
Transfer Function							*			*			
Total Error <sup>(1)</sup> ( $-10V \leq X, Y \leq +10V$ )	$\pm 2.0$			$\pm 1.0$			$\pm 0.5$			*			%
$T_A = \text{min to max}$	$\pm 2.5$			$\pm 1.5$			$\pm 1.0$			$\pm 2.0$			%
Total Error vs Temperature	$\pm 0.03$			$\pm 0.022$			$\pm 0.015$			$\pm 0.02$			%/°C
Scale Factor Error (SF = 10.000V Nominal) <sup>(2)</sup>	$\pm 0.25$			$\pm 0.1$			*			*			%
Temperature Coefficient of Scaling Voltage	$\pm 0.02$			$\pm 0.01$			$\pm 0.01$			*			%/°C
Supply Rejection ( $\pm 15V \pm 1V$ )	$\pm 0.01$			$\pm 0.01$			*			*			%
Nonlinearity													
X ( $X = 20V_{p-p}, Y = 10V$ )	$\pm 0.4$			$\pm 0.4$			0.2			*			%
Y ( $Y = 20V_{p-p}, X = 10V$ )	$\pm 0.01$			$\pm 0.01$			*			*			%
Feedthrough <sup>(3)</sup>													
X (Y Nulled, $X = 20V_{p-p}, 50\text{Hz}$ )	$\pm 0.3$			$\pm 0.3$			$\pm 0.15$			*			%
Y (X Nulled, $Y = 20V_{p-p}, 50\text{Hz}$ )	$\pm 0.01$			$\pm 0.01$			*			*			%
Both Inputs (500kHz, 1Vrms)													
Unnulled	40	50		45	55		*	60		*	*		dB
Nulled	55	60		55	65		60	70		*	*		dB
Output Offset Voltage	$\pm 50$			$\pm 5$			*			*			mV
Output Offset Voltage Drift	*			$\pm 200$			$\pm 15$			*			$\mu\text{V}/^\circ\text{C}$
<b>DYNAMICS</b>													
Small Signal BW, ( $V_{OUT} = 0.1V_{rms}$ )	6	10		8	10		*	*		6	*		MHz
1% Amplitude Error ( $C_{LOAD} = 1000\text{pF}$ )	100			100			*			*			kHz
Slew Rate ( $V_{OUT} = 20V_{p-p}$ )	20			20			*			*			V/ $\mu\text{s}$
Settling Time (to 1%, $\Delta V_{OUT} = 20V$ )	2			2			*			*			$\mu\text{s}$
<b>NOISE</b>													
Noise Spectral Density: SF = 10V	0.8			0.8			*			*			$\mu\text{V}/\sqrt{\text{Hz}}$
Wideband Noise: f = 10Hz to 5MHz	1			1			*			*			mVrms
f = 10Hz to 10kHz	90			90			*			*			$\mu\text{Vrms}$
<b>OUTPUT</b>													
Output Voltage Swing	$\pm 11$			$\pm 11$			*			*			V
Output Impedance (f $\leq 1\text{kHz}$ )	0.1			0.1			*			*			$\Omega$
Output Short Circuit Current ( $R_L = 0, T_A = \text{min to max}$ )	30			30			*			*			mA
Amplifier Open Loop Gain (f = 50Hz)	85			85			*			*			dB
<b>INPUT AMPLIFIERS (X, Y and Z)</b>													
Input Voltage Range													
Differential $V_{IN}$ ( $V_{CM} = 0$ )	$\pm 12$			$\pm 12$			*			*			V
Common-Mode $V_{IN}$ ( $V_{DIFF} = 0$ ) (see Typical Performance Curves)	$\pm 10$			$\pm 10$			*			*			V
Offset Voltage X, Y	$\pm 25$			$\pm 5$			$\pm 2$			*			mV
Offset Voltage Drift X, Y	200			100			50			*			$\mu\text{V}/^\circ\text{C}$
Offset Voltage Z	$\pm 25$			$\pm 5$			$\pm 2$			*			mV
Offset Voltage Drift Z	200			200			100			500			$\mu\text{V}/^\circ\text{C}$
CMRR	60	80		60	80		70	90		*	*		dB
Bias Current	0.8			0.8			2.0			*			$\mu\text{A}$
Offset Current	0.1			0.1			2.0			*			$\mu\text{A}$
Differential Resistance	10			10			*			*			M $\Omega$
<b>DIVIDER PERFORMANCE</b>													
Transfer Function ( $X_1 > X_2$ )	$10V \frac{(Z_2 - Z_1)}{(X_1 - X_2)} + Y_1$			$10V \frac{(Z_2 - Z_1)}{(X_1 - X_2)} + Y_1$			*			*			
Total Error <sup>(1)</sup> untrimmed ( $X = 10V, -10V \leq Z \leq +10V$ )	1.5			$\pm 0.75$			$\pm 0.35$			$\pm 0.75$			%
( $X = 1V, -1V \leq Z \leq +1V$ )	4.0			$\pm 2.0$			$\pm 1.0$			*			%
( $0.1V \leq X \leq 10V, -10V \leq Z \leq 10V$ )	5.0			$\pm 2.5$			$\pm 1.0$			*			%
<b>SQUARE PERFORMANCE</b>													
Transfer Function	$\frac{(X_1 - X_2)^2}{10V} + Z_2$			$\frac{(X_1 - X_2)^2}{10V} + Z_2$			*			*			
Total Error ( $-10V \leq X \leq 10V$ )	$\pm 1.2$			$\pm 0.6$			$\pm 0.3$			*			%

# SPECIFICATIONS (CONT)

## ELECTRICAL

At  $T_A = +25^\circ\text{C}$  and  $V_S = \pm 15\text{VDC}$ , unless otherwise noted.

MODEL	MPY634KP/KU			MPY634AM <b>OBSOLETE</b>			MPY634BM <b>OBSOLETE</b>			MPY634SM <b>OBSOLETE</b>			UNITS
	MIN	TYP	MAX	MIN	TYP	MAX	MIN	TYP	MAX	MIN	TYP	MAX	
<b>SQUARE-ROOTER PERFORMANCE</b> Transfer Function ( $Z_1 \leq Z_2$ ) Total Error <sup>(1)</sup> ( $1\text{V} \leq Z \leq 10\text{V}$ )	$\sqrt{10\text{V}(Z_2 - Z_1)} + X_2$			$\sqrt{10\text{V}(Z_2 - Z_1)} + X_2$				*			*		%
<b>POWER SUPPLY</b> Supply Voltage: Rated Performance Operating Supply Current, Quiescent	$\pm 8$	$\pm 15$	$\pm 18$	$\pm 8$	$\pm 15$	$\pm 18$	*	*	*	*	*	$\pm 20$	VDC VDC mA
<b>TEMPERATURE RANGE</b> Specification Storage	-40 -40		+85 +85	-25 -65		+85 +150	*	*	*	-55 *		+125 *	$^\circ\text{C}$ $^\circ\text{C}$

\* Specification same as for MPY634AM.

Gray indicates obsolete parts.

NOTES: (1) Figures given are percent of full scale,  $\pm 10\text{V}$  (i.e.,  $0.01\% = 1\text{mV}$ ). (2) May be reduced to  $3\text{V}$  using external resistor between  $-V_S$  and SF. (3) Irreducible component due to nonlinearity; excludes effect of offsets.

## PIN CONFIGURATIONS

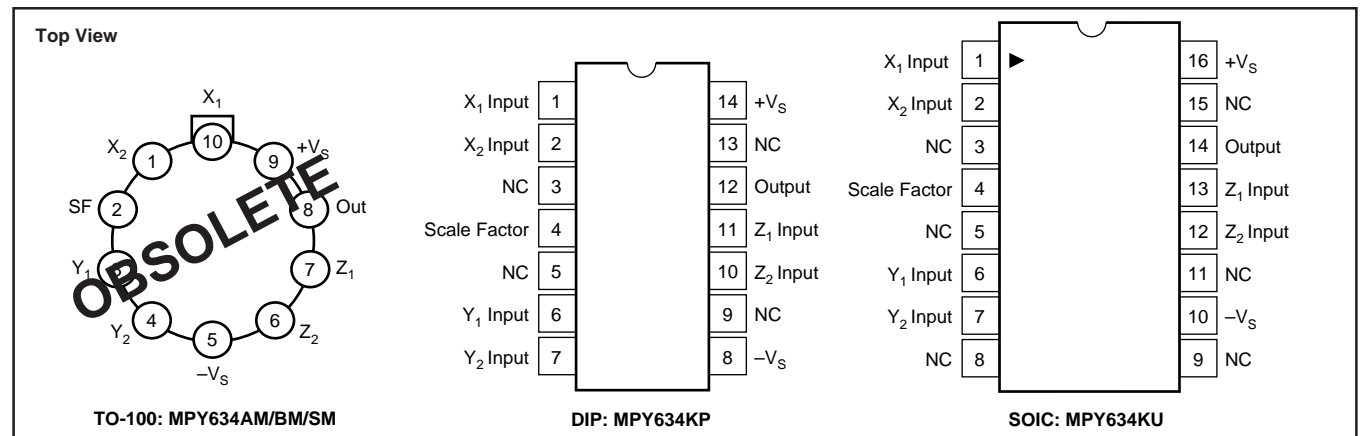

## ABSOLUTE MAXIMUM RATINGS

PARAMETER	MPY634AM/BM <b>OBSOLETE</b>	MPY634KP/KU	MPY634SM <b>OBSOLETE</b>
Power Supply Voltage	$\pm 18$	*	$\pm 20$
Power Dissipation	500mW	*	*
Output Short-Circuit to Ground	Indefinite	*	*
Input Voltage (all X, Y and Z)	$\pm V_S$	*	*
Temperature Range:			
Operating	$-25^\circ\text{C}/+85^\circ\text{C}$	$-40^\circ\text{C}/+85^\circ\text{C}$	$-55^\circ\text{C}/+125^\circ\text{C}$
Storage	$-65^\circ\text{C}/+150^\circ\text{C}$	$-40^\circ\text{C}/+85^\circ\text{C}$	*
Lead Temperature (soldering, 10s)	+300 $^\circ\text{C}$	*	*
SOIC 'KU' Package		+260 $^\circ\text{C}$	

\* Specification same as for MPY634AM/BM.

NOTE: Gray indicates obsolete parts.

## ORDERING INFORMATION

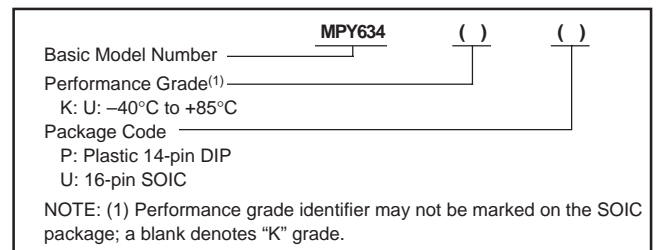

## PACKAGE INFORMATION<sup>(1)</sup>

PRODUCT	PACKAGE	PACKAGE DRAWING NUMBER
MPY634KP	14-Pin PDIP	010
MPY634KU	16-Pin SOIC	211

NOTE: (1) For the most current package and ordering information, see the Package Option Addendum located at the end of this data sheet.

# TYPICAL PERFORMANCE CURVES

At  $T_A = +25^\circ\text{C}$ ,  $V_S = \pm 15\text{VDC}$ , unless otherwise noted.

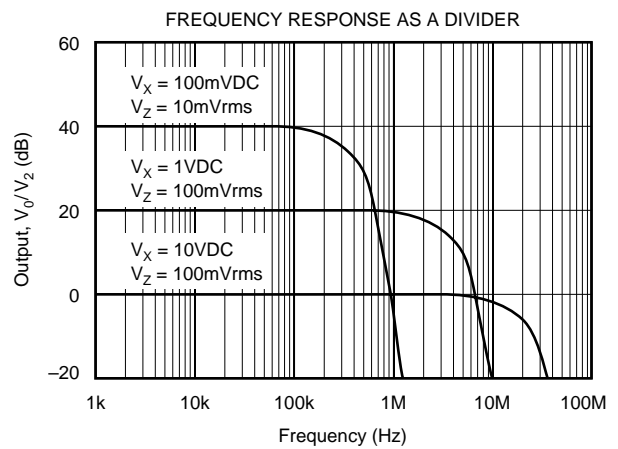
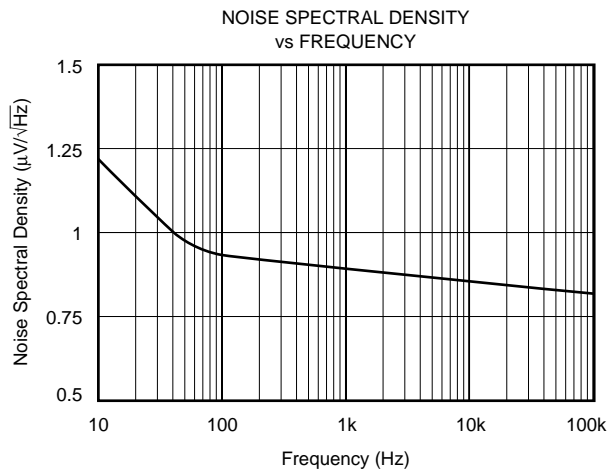
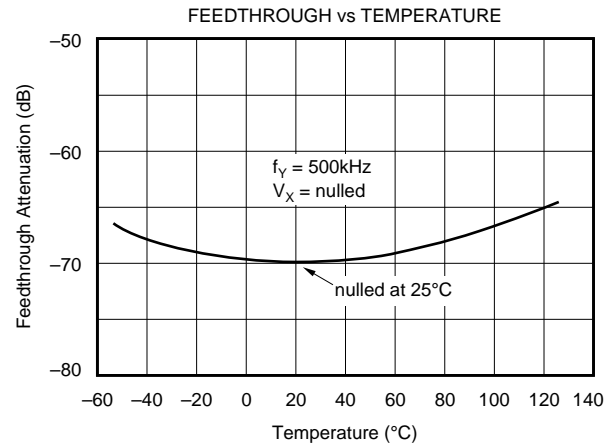
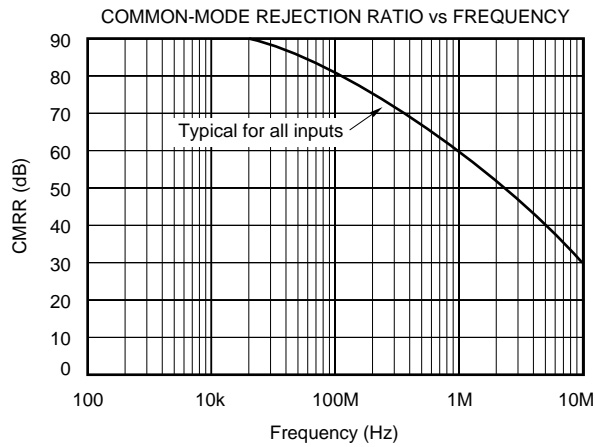
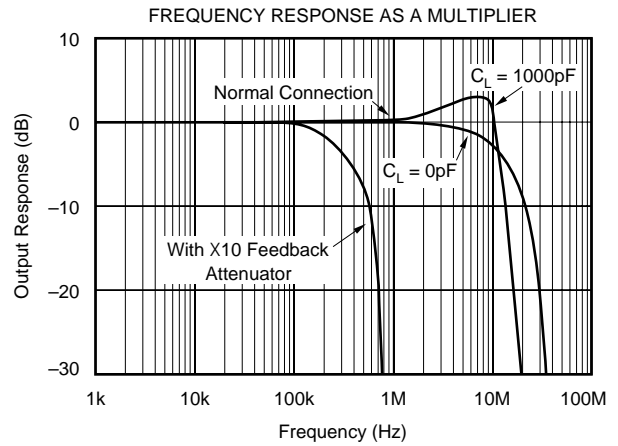
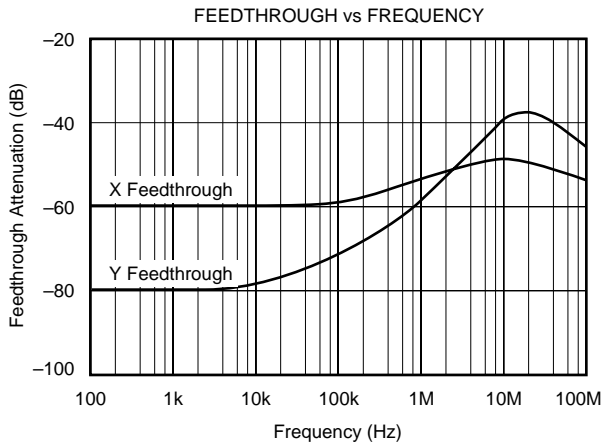

# TYPICAL PERFORMANCE CURVES (CONT)

$T_A = +25^\circ\text{C}$ ,  $V_S = \pm 15\text{VDC}$ , unless otherwise noted.

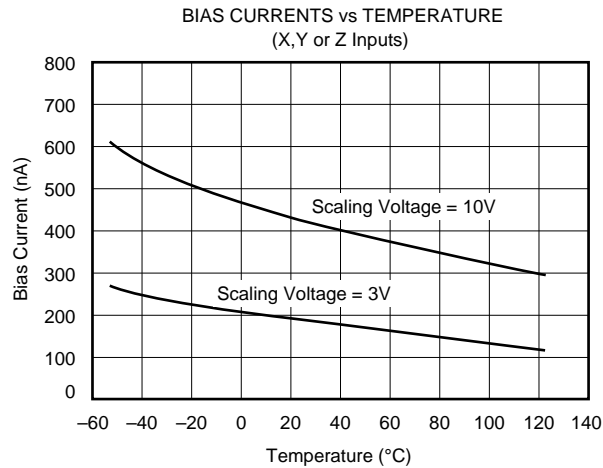
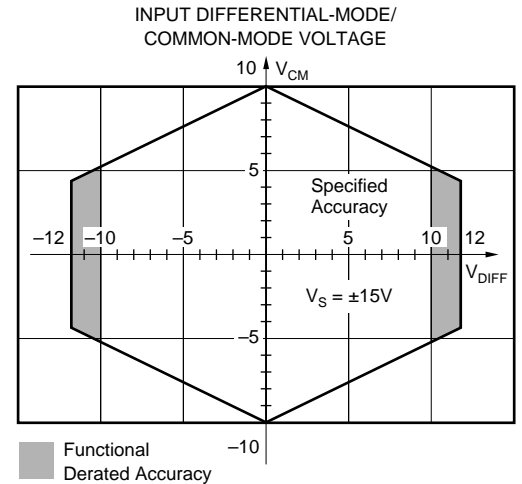
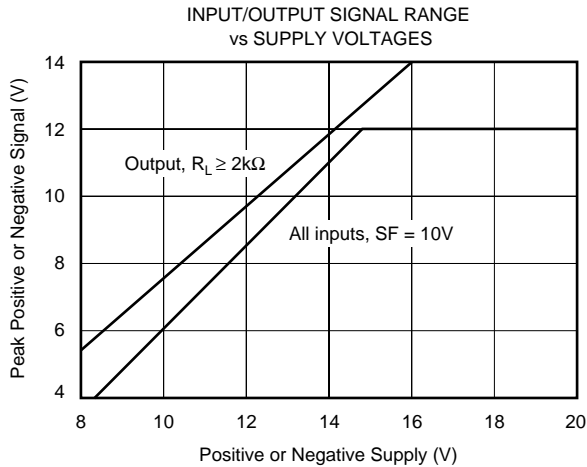

## THEORY OF OPERATION

The transfer function for the MPY634 is:

$$V_{OUT} = A \left[ \frac{(X_1 - X_2)(Y_1 - Y_2)}{SF} - (Z_1 - Z_2) \right]$$

where:

A = open-loop gain of the output amplifier (typically 85dB at DC).

SF = Scale Factor. Laser-trimmed to 10V but adjustable over a 3V to 10V range using external resistors.

X, Y, Z are input voltages. Full-scale input voltage is equal to the selected SF. (Max input voltage =  $\pm 1.25$  SF).

An intuitive understanding of transfer function can be gained by analogy to the op amp. By assuming that the open-loop gain, A, of the output operational amplifier is infinite,

inspection of the transfer function reveals that any  $V_{OUT}$  can be created with an infinitesimally small quantity within the brackets. Then, an application circuit can be analyzed by assigning circuit voltages for all X, Y and Z inputs and setting the bracketed quantity equal to zero. For example, the basic multiplier connection in Figure 1,  $Z_1 = V_{OUT}$  and  $Z_2 = 0$ . The quantity within the brackets then reduces to:

$$\frac{(X_1 - X_2)(Y_1 - Y_2)}{SF} - (V_{OUT} - 0) = 0$$

This approach leads to a simple relationship which can be solved for  $V_{OUT}$  to provide the closed-loop transfer function.

The scale factor is accurately factory adjusted to 10V and is typically accurate to within 0.1% or less. The scale factor may be adjusted by connecting a resistor or potentiometer between pin SF and the  $-V_S$  power supply. The value of the external resistor can be approximated by:

$$R_{SF} = 5.4k\Omega \left( \frac{SF}{10 - SF} \right)$$

Internal device tolerances make this relationship accurate to within approximately 25%. Some applications can benefit from reduction of the SF by this technique. The reduced input bias current, noise, and drift achieved by this technique can be likened to operating the input circuitry in a higher gain, thus reducing output contributions to these effects. Adjustment of the scale factor does not affect bandwidth.

The MPY634 is fully characterized at  $V_S = \pm 15V$  but operation is possible down to  $\pm 8V$  with an attendant reduction of input and output range capability. Operation at voltages greater than  $\pm 15V$  allows greater output swing to be achieved by using an output feedback attenuator (Figure 1).

As with any wide bandwidth circuit, the power supplies should be bypassed with high frequency ceramic capacitors. These capacitors should be located as near as practical to the power supply connections of the MPY634. Improper bypassing can lead to instability, overshoot, and ringing in the output.

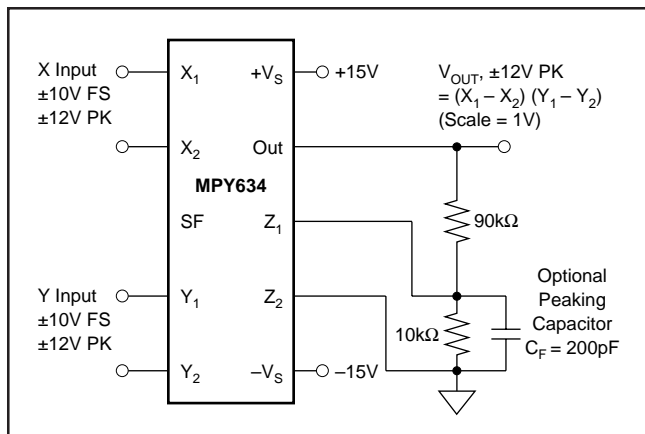

FIGURE 1. Connections for Scale-Factor of Unity.

## BASIC MULTIPLIER CONNECTION

Figure 2 shows the basic connection as a multiplier. Accuracy is fully specified without any additional user-trimming circuitry. Some applications can benefit from trimming of one or more of the inputs. The fully differential inputs facilitate referencing the input quantities to the source voltage common terminal for maximum accuracy. They also allow use of simple offset voltage trimming circuitry as shown on the X input.

The differential Z input allows an offset to be summed in  $V_{OUT}$ . In basic multiplier operation, the  $Z_2$  input serves as the output voltage ground reference and should be connected to the ground of the driven system for maximum accuracy.

A method of changing (lowering) SF by connecting to the SF pin was discussed previously. Figure 1 shows an alternative method of changing the effective SF of the overall circuit by using an attenuator in the feedback connection to  $Z_1$ . This method puts the output amplifier in a higher gain and is thus accompanied by a reduction in bandwidth and an

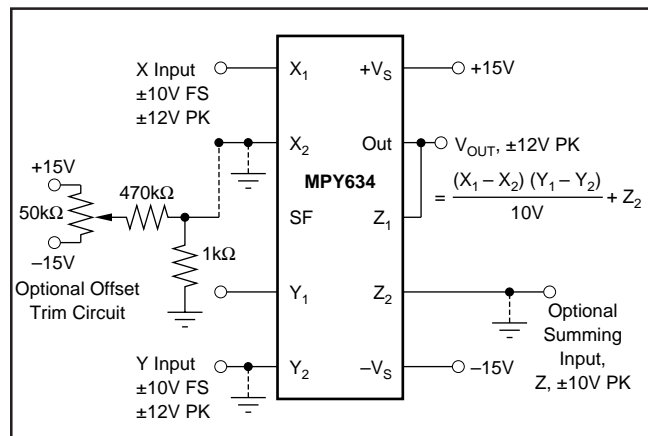

FIGURE 2. Basic Multiplier Connection.

increase in output offset voltage. The larger output offset may be reduced by applying a trimming voltage to the high impedance input,  $Z_2$ .

The flexibility of the differential Z inputs allows direct conversion of the output quantity to a current. Figure 3 shows the output voltage differentially-sensed across a series resistor forcing an output-controlled current. Addition of a capacitor load then creates a time integration function useful in a variety of applications such as power computation.

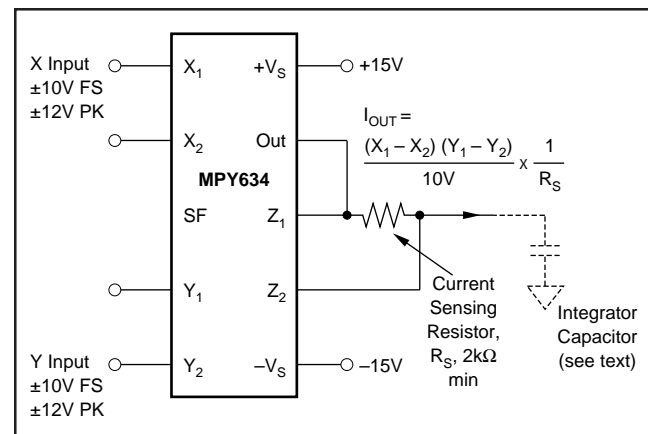

FIGURE 3. Conversion of Output to Current.

## SQUARER CIRCUIT (FREQUENCY DOUBLER)

Squarer, or frequency doubler, operation is achieved by paralleling the X and Y inputs of the standard multiplier circuit. Inverted output can be achieved by reversing the differential input terminals of either the X or Y input. Accuracy in the squaring mode is typically a factor of two better than the specified multiplier mode with maximum error occurring with small (less than 1V) inputs. Better accuracy can be achieved for small input voltage levels by reducing the scale factor, SF.

## DIVIDER OPERATION

The MPY634 can be configured as a divider as shown in Figure 4. High impedance differential inputs for the numerator and denominator are achieved at the Z and X inputs,

respectively. Feedback is applied to the  $Y_2$  input, and  $Y_1$  is normally referenced to output ground. Alternatively, as the transfer function implies, an input applied to  $Y_1$  can be summed directly into  $V_{OUT}$ . Since the feedback connection is made to a multiplying input, the effective gain of the output op amp varies as a function of the denominator input voltage. Therefore, the bandwidth of the divider function is proportional to the denominator voltage (see Typical Performance Curves).

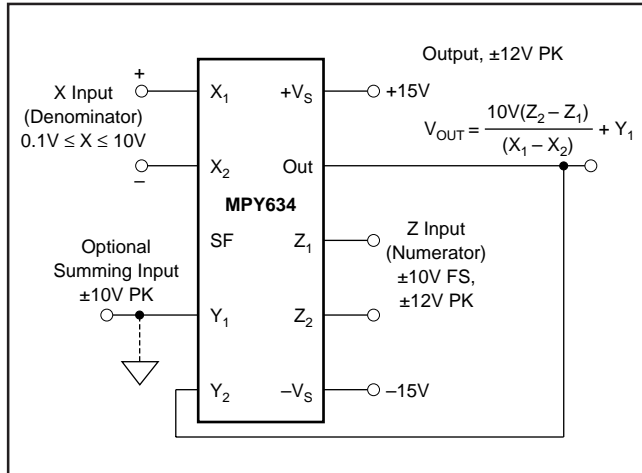

FIGURE 4. Basic Divider Connection.

Accuracy of the divider mode typically ranges from 1.0% to 2.5% for a 10 to 1 denominator range depending on device grade. Accuracy is primarily limited by input offset voltages and can be significantly improved by trimming the offset of the X input. A trim voltage of  $\pm 3.5\text{mV}$  applied to the “low side” X input ( $X_2$  for positive input voltages on  $X_1$ ) can produce similar accuracies over 100 to 1 denominator range. To trim, apply a signal which varies from 100mV to 10V at a low frequency (less than 500Hz). An offset sine wave or ramp is suitable. Since the ratio of the quantities should be constant, the ideal output would be a constant 10V. Using AC coupling on an oscilloscope, adjust the offset control for minimum output voltage variation.

## SQUARE-ROOTER

A square-rooter connection is shown in Figure 5. Input voltage is limited to one polarity (positive for the connection shown). The diode prevents circuit latch-up should the input go negative. The circuit can be configured for negative input and positive output by reversing the polarity of both the X and Y inputs. The output polarity can be reversed by reversing the diode and X input polarity. A load resistance of approximately 10k $\Omega$  must be provided. Trimming for improved accuracy would be accomplished at the Z input.

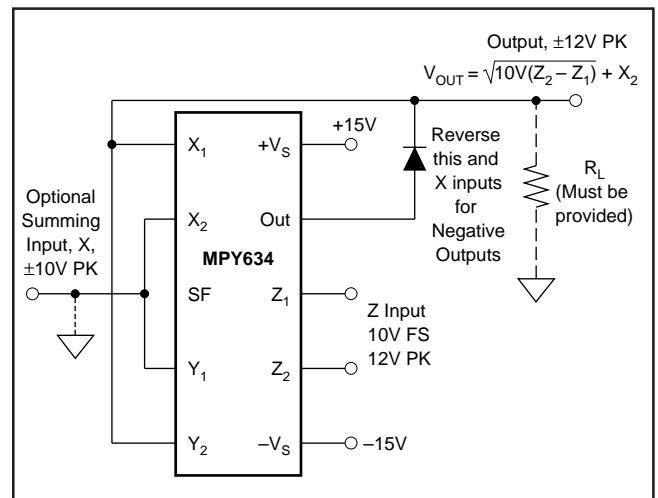

FIGURE 5. Square-Rooter Connection.

## APPLICATIONS

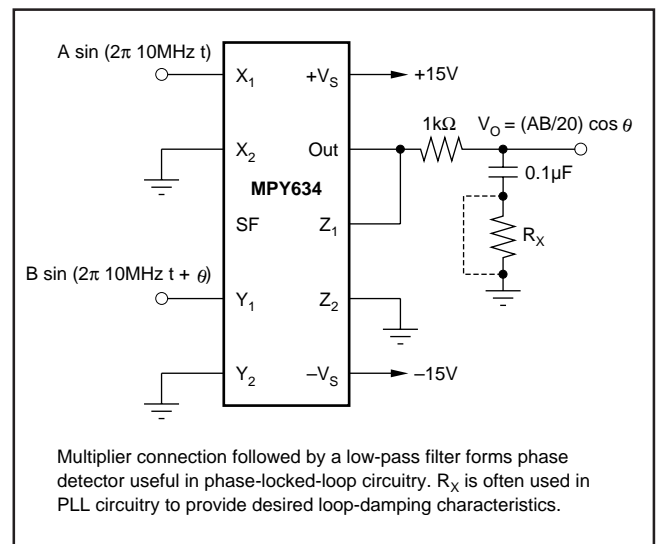

FIGURE 6. Phase Detector.

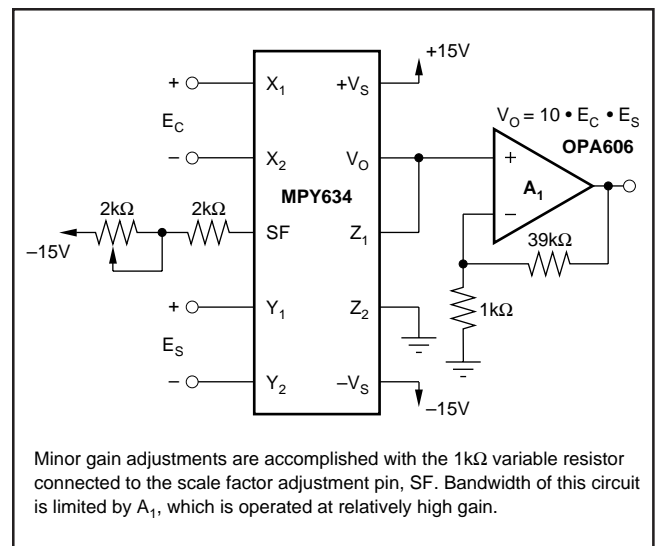

FIGURE 7. Voltage-Controlled Amplifier.

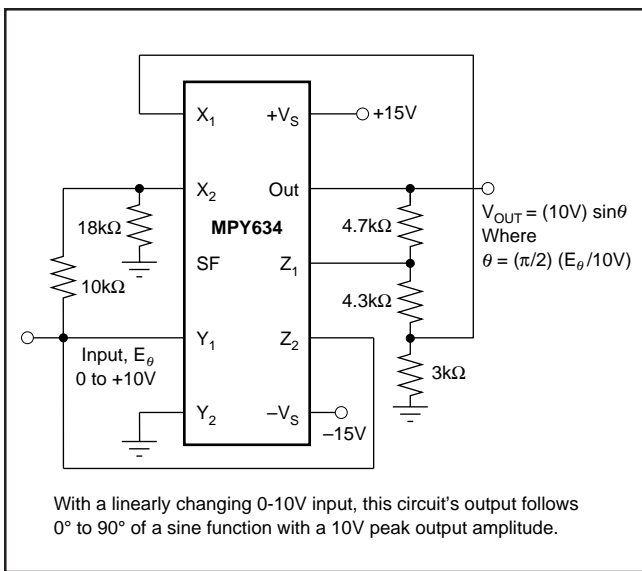

FIGURE 8. Sine-Function Generator.

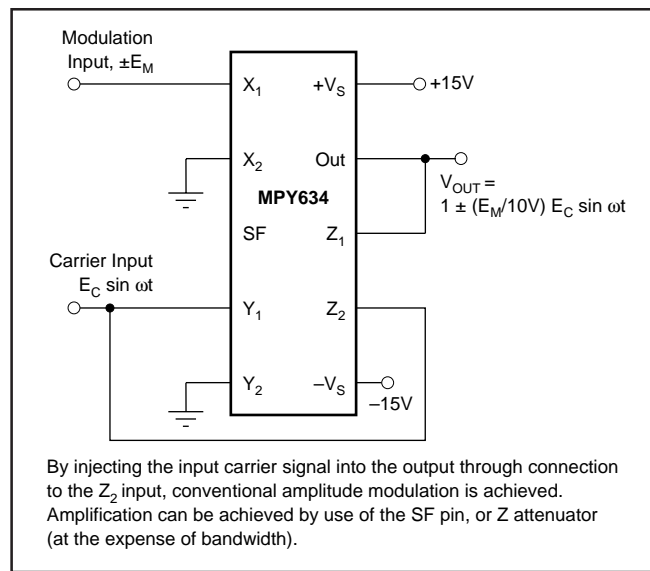

FIGURE 9. Linear AM Modulator.

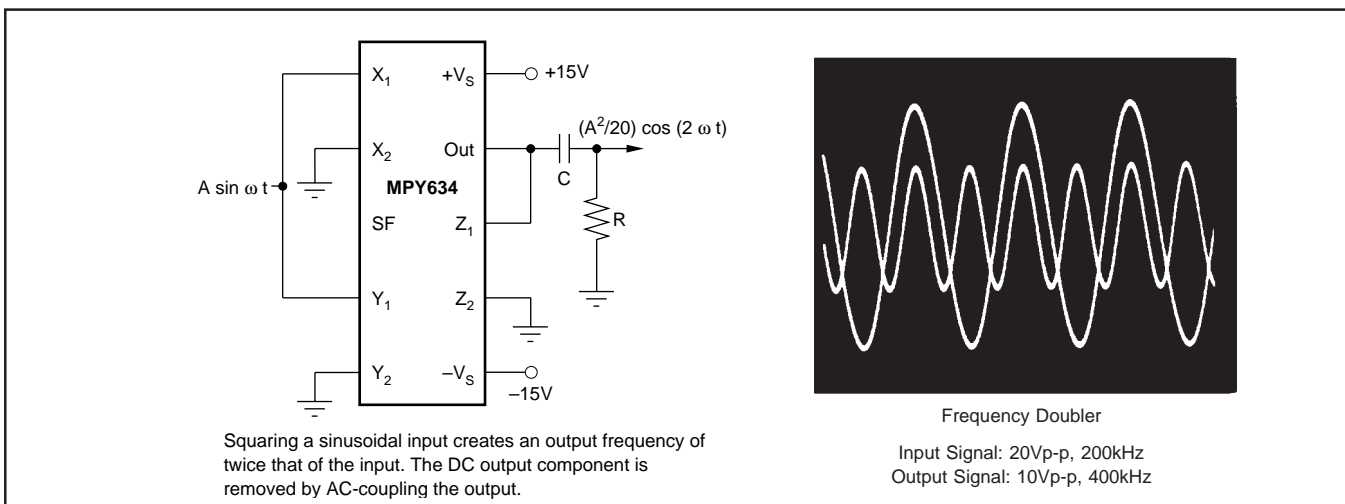

FIGURE 10. Frequency Doubler.

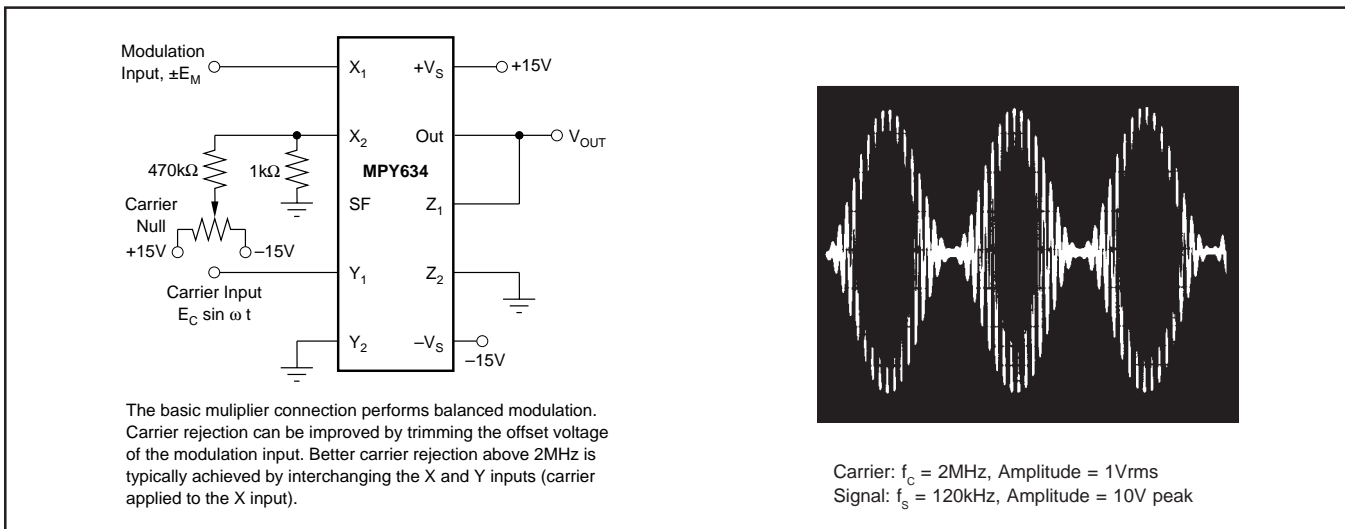

FIGURE 11. Balanced Modulator.

**PACKAGING INFORMATION**

Orderable Device	Status <sup>(1)</sup>	Package Type	Package Drawing	Pins	Package Qty	Eco Plan <sup>(2)</sup>	Lead/Ball Finish	MSL Peak Temp <sup>(3)</sup>
MPY634AM	OBSOLETE	TO-100	LME	10		None	Call TI	Call TI
MPY634BM	OBSOLETE	TO-100	LME	10		None	Call TI	Call TI
MPY634KP	ACTIVE	PDIP	N	14	25	Pb-Free (RoHS)	Call TI	Level-NC-NC-NC
MPY634KU	ACTIVE	SOIC	DW	16	48	None	CU SNPB	Level-3-220C-168 HR
MPY634KU/1K	ACTIVE	SOIC	DW	16	1000	None	CU SNPB	Level-3-220C-168 HR

<sup>(1)</sup> The marketing status values are defined as follows:

**ACTIVE:** Product device recommended for new designs.

**LIFEBUY:** TI has announced that the device will be discontinued, and a lifetime-buy period is in effect.

**NRND:** Not recommended for new designs. Device is in production to support existing customers, but TI does not recommend using this part in a new design.

**PREVIEW:** Device has been announced but is not in production. Samples may or may not be available.

**OBSOLETE:** TI has discontinued the production of the device.

<sup>(2)</sup> Eco Plan - May not be currently available - please check <http://www.ti.com/productcontent> for the latest availability information and additional product content details.

**None:** Not yet available Lead (Pb-Free).

**Pb-Free (RoHS):** TI's terms "Lead-Free" or "Pb-Free" mean semiconductor products that are compatible with the current RoHS requirements for all 6 substances, including the requirement that lead not exceed 0.1% by weight in homogeneous materials. Where designed to be soldered at high temperatures, TI Pb-Free products are suitable for use in specified lead-free processes.

**Green (RoHS & no Sb/Br):** TI defines "Green" to mean "Pb-Free" and in addition, uses package materials that do not contain halogens, including bromine (Br) or antimony (Sb) above 0.1% of total product weight.

<sup>(3)</sup> MSL, Peak Temp. -- The Moisture Sensitivity Level rating according to the JEDEC industry standard classifications, and peak solder temperature.

**Important Information and Disclaimer:** The information provided on this page represents TI's knowledge and belief as of the date that it is provided. TI bases its knowledge and belief on information provided by third parties, and makes no representation or warranty as to the accuracy of such information. Efforts are underway to better integrate information from third parties. TI has taken and continues to take reasonable steps to provide representative and accurate information but may not have conducted destructive testing or chemical analysis on incoming materials and chemicals. TI and TI suppliers consider certain information to be proprietary, and thus CAS numbers and other limited information may not be available for release.

In no event shall TI's liability arising out of such information exceed the total purchase price of the TI part(s) at issue in this document sold by TI to Customer on an annual basis.



N (R-PDIP-T\*\*)

PLASTIC DUAL-IN-LINE PACKAGE

16 PINS SHOWN



- NOTES:
- A. All linear dimensions are in inches (millimeters).
  - B. This drawing is subject to change without notice.
  - Falls within JEDEC MS-001, except 18 and 20 pin minimum body length (Dim A).
  - The 20 pin end lead shoulder width is a vendor option, either half or full width.

DW (R-PDSO-G16)

PLASTIC SMALL-OUTLINE PACKAGE

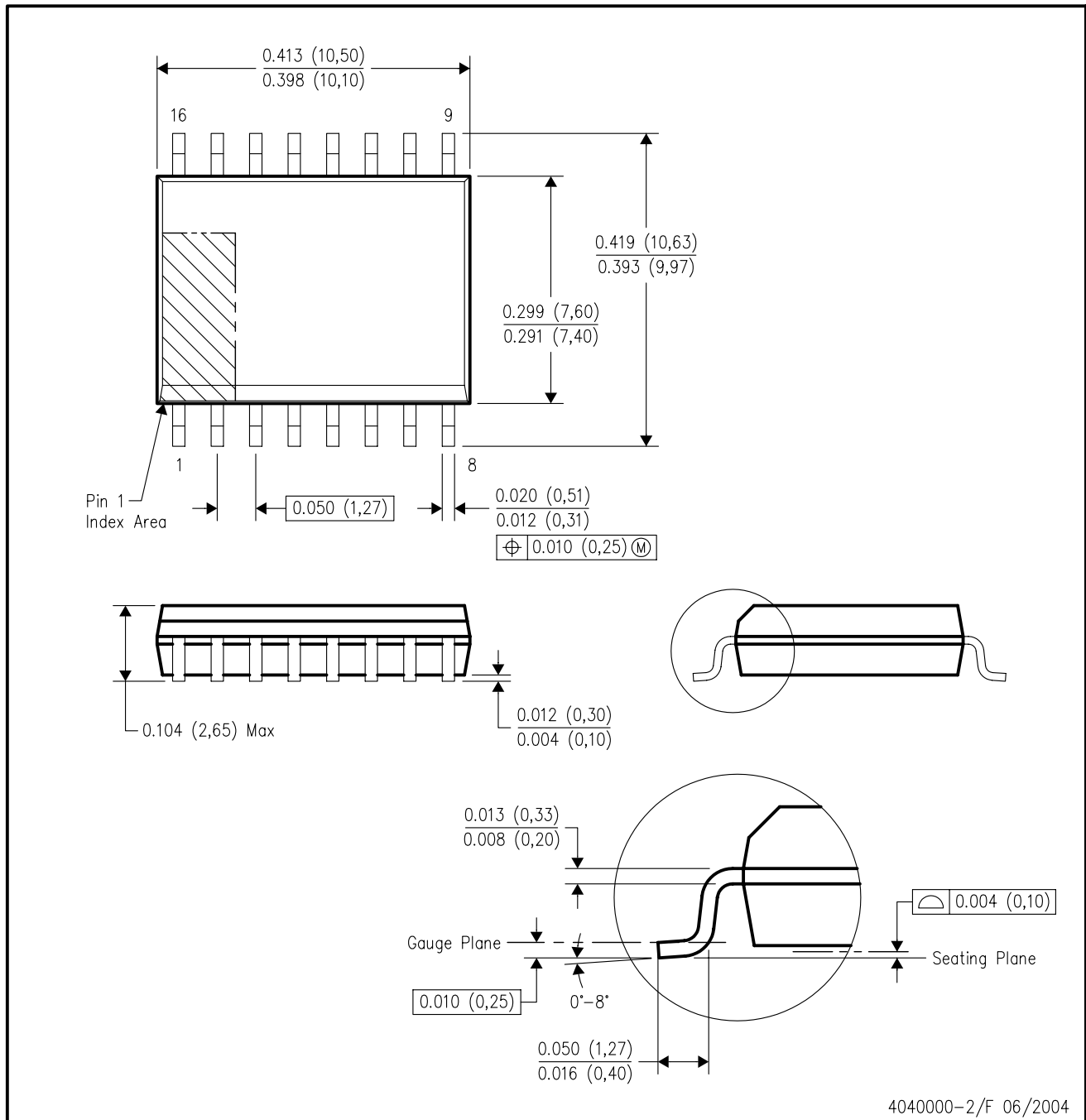

4040000-2/F 06/2004

- NOTES:
- A. All linear dimensions are in inches (millimeters).
  - B. This drawing is subject to change without notice.
  - C. Body dimensions do not include mold flash or protrusion not to exceed 0.006 (0,15).
  - D. Falls within JEDEC MS-013 variation AA.

## IMPORTANT NOTICE

Texas Instruments Incorporated and its subsidiaries (TI) reserve the right to make corrections, modifications, enhancements, improvements, and other changes to its products and services at any time and to discontinue any product or service without notice. Customers should obtain the latest relevant information before placing orders and should verify that such information is current and complete. All products are sold subject to TI's terms and conditions of sale supplied at the time of order acknowledgment.

TI warrants performance of its hardware products to the specifications applicable at the time of sale in accordance with TI's standard warranty. Testing and other quality control techniques are used to the extent TI deems necessary to support this warranty. Except where mandated by government requirements, testing of all parameters of each product is not necessarily performed.

TI assumes no liability for applications assistance or customer product design. Customers are responsible for their products and applications using TI components. To minimize the risks associated with customer products and applications, customers should provide adequate design and operating safeguards.

TI does not warrant or represent that any license, either express or implied, is granted under any TI patent right, copyright, mask work right, or other TI intellectual property right relating to any combination, machine, or process in which TI products or services are used. Information published by TI regarding third-party products or services does not constitute a license from TI to use such products or services or a warranty or endorsement thereof. Use of such information may require a license from a third party under the patents or other intellectual property of the third party, or a license from TI under the patents or other intellectual property of TI.

Reproduction of information in TI data books or data sheets is permissible only if reproduction is without alteration and is accompanied by all associated warranties, conditions, limitations, and notices. Reproduction of this information with alteration is an unfair and deceptive business practice. TI is not responsible or liable for such altered documentation.

Resale of TI products or services with statements different from or beyond the parameters stated by TI for that product or service voids all express and any implied warranties for the associated TI product or service and is an unfair and deceptive business practice. TI is not responsible or liable for any such statements.

Following are URLs where you can obtain information on other Texas Instruments products and application solutions:

<b>Products</b>		<b>Applications</b>	
Amplifiers	<a href="http://amplifier.ti.com">amplifier.ti.com</a>	Audio	<a href="http://www.ti.com/audio">www.ti.com/audio</a>
Data Converters	<a href="http://dataconverter.ti.com">dataconverter.ti.com</a>	Automotive	<a href="http://www.ti.com/automotive">www.ti.com/automotive</a>
DSP	<a href="http://dsp.ti.com">dsp.ti.com</a>	Broadband	<a href="http://www.ti.com/broadband">www.ti.com/broadband</a>
Interface	<a href="http://interface.ti.com">interface.ti.com</a>	Digital Control	<a href="http://www.ti.com/digitalcontrol">www.ti.com/digitalcontrol</a>
Logic	<a href="http://logic.ti.com">logic.ti.com</a>	Military	<a href="http://www.ti.com/military">www.ti.com/military</a>
Power Mgmt	<a href="http://power.ti.com">power.ti.com</a>	Optical Networking	<a href="http://www.ti.com/opticalnetwork">www.ti.com/opticalnetwork</a>
Microcontrollers	<a href="http://microcontroller.ti.com">microcontroller.ti.com</a>	Security	<a href="http://www.ti.com/security">www.ti.com/security</a>
		Telephony	<a href="http://www.ti.com/telephony">www.ti.com/telephony</a>
		Video & Imaging	<a href="http://www.ti.com/video">www.ti.com/video</a>
		Wireless	<a href="http://www.ti.com/wireless">www.ti.com/wireless</a>

Mailing Address: Texas Instruments  
Post Office Box 655303 Dallas, Texas 75265