



OPA121

Low Cost Precision *Difet*[®] OPERATIONAL AMPLIFIER

FEATURES

- LOW NOISE: $6\text{nV}/\sqrt{\text{Hz}}$ typ at 10kHz
- LOW BIAS CURRENT: 5pA max
- LOW OFFSET: 2mV max
- LOW DRIFT: $3\mu\text{V}/^\circ\text{C}$ typ
- HIGH OPEN-LOOP GAIN: 110dB min
- HIGH COMMON-MODE REJECTION: 86dB min

APPLICATIONS

- OPTOELECTRONICS
- DATA ACQUISITION
- TEST EQUIPMENT
- MEDICAL EQUIPMENT
- RADIATION HARD EQUIPMENT

DESCRIPTION

The OPA121 is a precision monolithic dielectrically-isolated FET (*Difet*[®]) operational amplifier. Outstanding performance characteristics are now available for low-cost applications.

Noise, bias current, voltage offset, drift, open-loop gain, common-mode rejection, and power supply rejection are superior to BIFET[®] amplifiers.

Very low bias current is obtained by dielectric isolation with on-chip guarding.

Laser-trimming of thin-film resistors gives very low offset and drift. Extremely low noise is achieved with new circuit design techniques (patented). A new cascode design allows high precision input specifications and reduced susceptibility to flicker noise.

Standard 741 pin configuration allows upgrading of existing designs to higher performance levels.

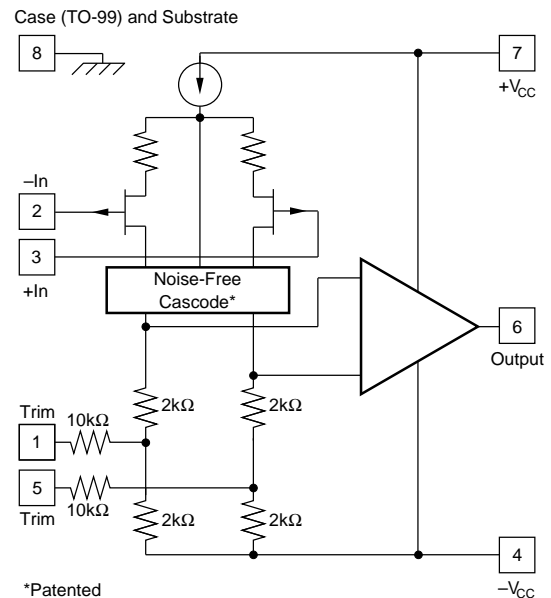

OPA121 Simplified Circuit

Difet[®], Burr-Brown Corp.
BIFET[®], National Semiconductor Corp.

International Airport Industrial Park • Mailing Address: PO Box 11400 • Tucson, AZ 85734 • Street Address: 6730 S. Tucson Blvd. • Tucson, AZ 85706
Tel: (520) 746-1111 • Twx: 910-952-1111 • Cable: BBRCORP • Telex: 066-6491 • FAX: (520) 889-1510 • Immediate Product Info: (800) 548-6132

SPECIFICATIONS

ELECTRICAL

At $V_{CC} = \pm 15\text{VDC}$ and $T_A = +25^\circ\text{C}$ unless otherwise noted. Pin 8 connected to ground.

PARAMETER	CONDITIONS	OPA121KM			OPA121KP, KU			UNITS
		MIN	TYP	MAX	MIN	TYP	MAX	
INPUT NOISE Voltage, $f_O = 10\text{Hz}$ $f_O = 100\text{Hz}$ $f_O = 1\text{kHz}$ $f_O = 10\text{kHz}$ $f_B = 10\text{Hz}$ to 10kHz $f_B = 0.1\text{Hz}$ to 10Hz Current, $f_B = 0.1\text{Hz}$ to 10Hz $f_O = 0.1\text{Hz}$ thru 20kHz	(1) (1) (1) (1) (1) (1) (1)		40 15 8 6 0.7 1.6 15 0.8			50 18 10 7 0.8 2 21 1.1		$\text{nV}/\sqrt{\text{Hz}}$ $\text{nV}/\sqrt{\text{Hz}}$ $\text{nV}/\sqrt{\text{Hz}}$ $\text{nV}/\sqrt{\text{Hz}}$ μVrms $\mu\text{Vp-p}$ fA, p-p $\text{fA}/\sqrt{\text{Hz}}$
OFFSET VOLTAGE⁽²⁾ Input Offset Voltage Average Drift Supply Rejection	$V_{CM} = 0\text{VDC}$ $T_A = T_{MIN}$ to T_{MAX}		± 0.5 ± 3 ± 6	± 2 ± 10 ± 50		± 0.5 ± 3 ± 6	± 3 ± 10 ± 50	mV $\mu\text{V}/^\circ\text{C}$ dB $\mu\text{V}/\text{V}$
BIAS CURRENT⁽²⁾ Input Bias Current	$V_{CM} = 0\text{VDC}$ Device Operating		± 1	± 5		± 1	± 10	pA
OFFSET CURRENT⁽²⁾ Input Offset Current	$V_{CM} = 0\text{VDC}$ Device Operating		± 0.7	± 4		± 0.7	± 8	pA
IMPEDANCE Differential Common-Mode			$10^{13} \parallel 1$ $10^{14} \parallel 3$			$10^{13} \parallel 1$ $10^{14} \parallel 3$		$\Omega \parallel \text{pF}$ $\Omega \parallel \text{pF}$
VOLTAGE RANGE Common-Mode Input Range Common-Mode Rejection	$V_{IN} = \pm 10\text{VDC}$	± 10 86	± 11 104		± 10 82	± 11 100		V dB
OPEN-LOOP GAIN, DC Open-Loop Voltage Gain	$R_L \geq 2\text{k}\Omega$	110	120		106	114		dB
FREQUENCY RESPONSE Unity Gain, Small Signal Full Power Response Slew Rate Settling Time, 0.1% 0.01% Overload Recovery, 50% Overdrive ⁽³⁾	20Vp-p, $R_L = 2\text{k}\Omega$ $V_O = \pm 10\text{V}$, $R_L = 2\text{k}\Omega$ Gain = -1, $R_L = 2\text{k}\Omega$ 10V Step Gain = -1		2 32 2 6 10 5			2 32 2 6 10 5		MHz kHz V/ μs μs μs μs
RATED OUTPUT Voltage Output Current Output Output Resistance Load Capacitance Stability Short Circuit Current	$R_L = 2\text{k}\Omega$ $V_O = \pm 10\text{VDC}$ DC, Open Loop Gain = +1	± 11 ± 5.5	± 12 ± 10 100 1000 40		± 11 ± 5.5	± 12 ± 10 100 1000 40		V mA Ω pF mA
POWER SUPPLY Rated Voltage Voltage Range, Derated Performance Current, Quiescent	$I_O = 0\text{mA DC}$		± 15			± 15		VDC VDC VDC mA
TEMPERATURE RANGE Specification Operating Storage θ Junction-Ambient	Ambient Temperature Ambient Temperature Ambient Temperature	0 -40 -65		+70 +85 +150	0 -25 -55		+70 +85 +125	$^\circ\text{C}$ $^\circ\text{C}$ $^\circ\text{C}$ $^\circ\text{C}/\text{W}$

NOTES: (1) Sample tested. (2) Offset voltage, offset current, and bias current are specified with the units fully warmed up. (3) Overload recovery is defined as the time required for the output to return from saturation to linear operation following the removal of a 50% input overdrive. (4) $100^\circ\text{C}/\text{W}$ for KU grade.

The information provided herein is believed to be reliable; however, BURR-BROWN assumes no responsibility for inaccuracies or omissions. BURR-BROWN assumes no responsibility for the use of this information, and all use of such information shall be entirely at the user's own risk. Prices and specifications are subject to change without notice. No patent rights or licenses to any of the circuits described herein are implied or granted to any third party. BURR-BROWN does not authorize or warrant any BURR-BROWN product for use in life support devices and/or systems.

ELECTRICAL (FULL TEMPERATURE RANGE SPECIFICATIONS)

At $V_{CC} = \pm 15\text{VDC}$ and $T_A = T_{MIN}$ to T_{MAX} unless otherwise noted.

PARAMETER	CONDITIONS	OPA121KM			OPA121KP, KU			UNITS
		MIN	TYP	MAX	MIN	TYP	MAX	
TEMPERATURE RANGE Specification Range	Ambient Temperature	0		+70	0		+70	°C
INPUT OFFSET VOLTAGE⁽¹⁾ Input Offset Voltage Average Drift Supply Rejection	$V_{CM} = 0\text{VDC}$		± 1 ± 3 94	± 3 ± 10 ± 80		± 1 ± 3 94 ± 20	± 5 ± 10 ± 80	mV $\mu\text{V}/^\circ\text{C}$ dB $\mu\text{V}/\text{V}$
BIAS CURRENT⁽¹⁾ Input Bias Current	$V_{CM} = 0\text{VDC}$ Device Operating		± 23	± 115		± 23	± 250	pA
OFFSET CURRENT⁽¹⁾ Input Offset Current	$V_{CM} = 0\text{VDC}$ Device Operating		± 16	± 100		± 16	± 200	pA
VOLTAGE RANGE Common-Mode Input Range Common-Mode Rejection	$V_{IN} = \pm 10\text{VDC}$	± 10 82	± 11 98		± 10 80	± 11 96		V dB
OPEN-LOOP GAIN, DC Open-Loop Voltage Gain	$R_L \geq 2\text{k}\Omega$	106	116		100	110		dB
RATED OUTPUT Voltage Output Current Output Short Circuit Current	$R_L = 2\text{k}\Omega$ $V_O = \pm 10\text{VDC}$ $V_O = 0\text{VDC}$	± 10.5 ± 5.25 10	± 11 ± 10 40		± 10.5 ± 5.25 10	± 11 ± 10 40		V mA mA
POWER SUPPLY Current, Quiescent	$I_O = 0\text{mADC}$		2.5	4.5		2.5	5	mA

NOTE: (1) Offset voltage, offset current, and bias current are measured with the units fully warmed up.

ABSOLUTE MAXIMUM RATINGS

Supply	$\pm 18\text{VDC}$
Internal Power Dissipation ⁽¹⁾	500mW
Differential Input Voltage	$\pm 36\text{VDC}$
Input Voltage Range	$\pm 18\text{VDC}$
Storage Temperature Range	
M package	-65°C to $+150^\circ\text{C}$
P, U packages	-55°C to $+125^\circ\text{C}$
Operating Temperature Range	
M package	-40°C to $+85^\circ\text{C}$
P, U packages	-25°C to $+85^\circ\text{C}$
Lead Temperature	
M, P packages (soldering, 10s)	$+300^\circ\text{C}$
U package (soldering, 3s)	$+260^\circ\text{C}$
Output Short-Circuit Duration ⁽²⁾	Continuous
Junction Temperature	$+175^\circ\text{C}$

NOTES: (1) Packages must be derated based on $\theta_{JA} = 150^\circ\text{C}/\text{W}$ (P package); $\theta_{JA} = 200^\circ\text{C}/\text{W}$ (M package); $\theta_{JA} = 100^\circ\text{C}/\text{W}$ (U package).
(2) Short circuit may be to power supply common only. Rating applies to $+25^\circ\text{C}$ ambient. Observe dissipation limit and T_J .

PACKAGE INFORMATION

MODEL	PACKAGE	PACKAGE DRAWING NUMBER ⁽¹⁾
OPA121KM	TO-99	001
OPA121KP	8-Pin Plastic DIP	006
OPA121KU	8-Pin SOIC	182

NOTE: (1) For detailed drawing and dimension table, please see end of data sheet, or Appendix D of Burr-Brown IC Data Book.

ORDERING INFORMATION

MODEL	PACKAGE	TEMPERATURE RANGE
OPA121KM	TO-99	0°C to $+70^\circ\text{C}$
OPA121KP	8-Pin Plastic DIP	0°C to $+70^\circ\text{C}$
OPA121KU	8-Pin SOIC	0°C to $+70^\circ\text{C}$

CONNECTION DIAGRAMS

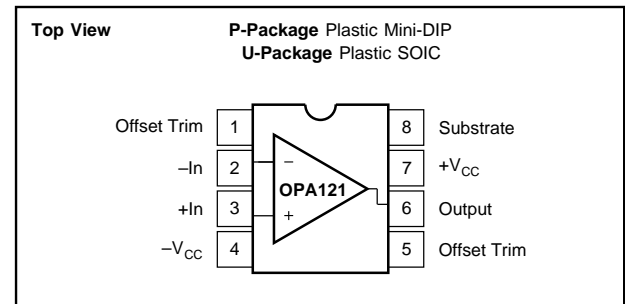
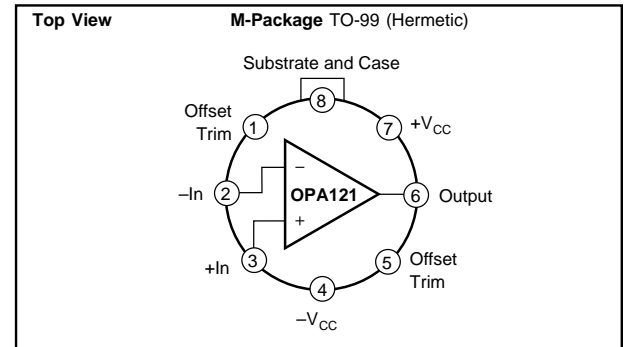

TYPICAL PERFORMANCE CURVES

$T_A = +25^\circ\text{C}$, $V_{CC} = \pm 15\text{VDC}$ unless otherwise noted.

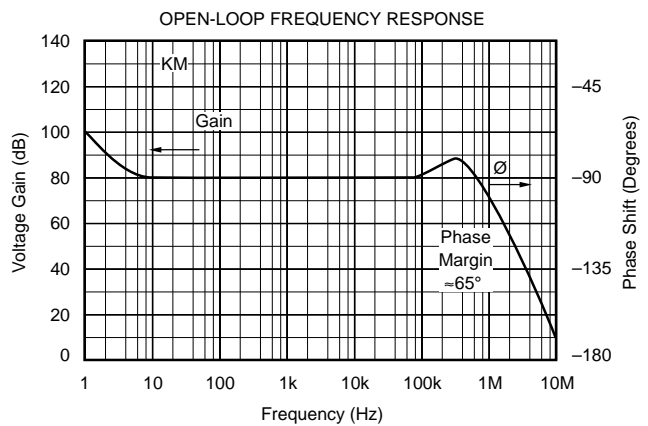
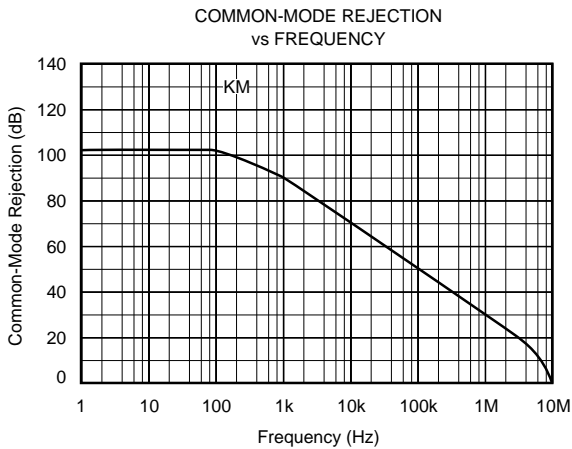
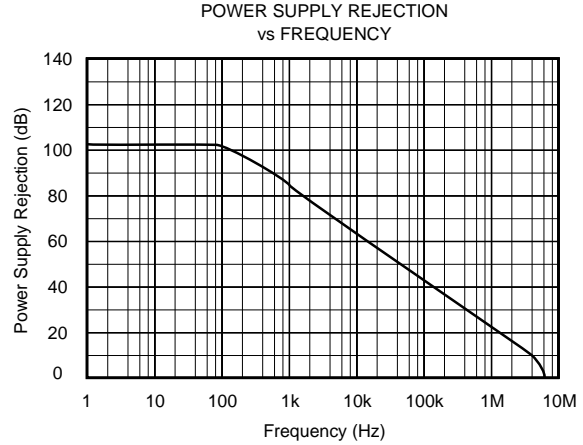
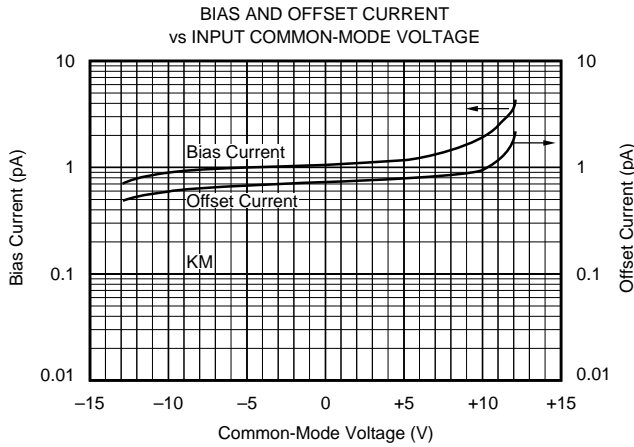
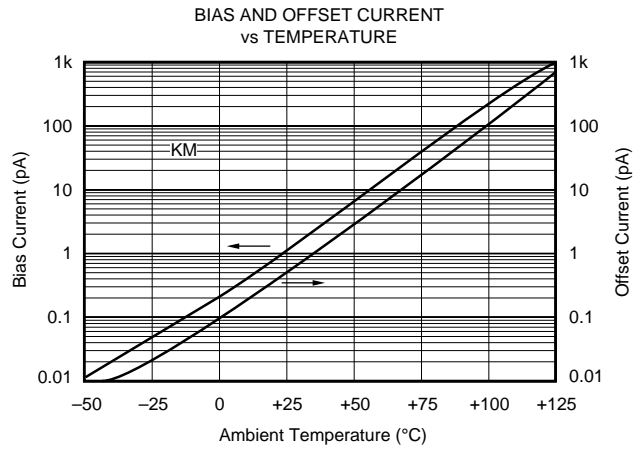
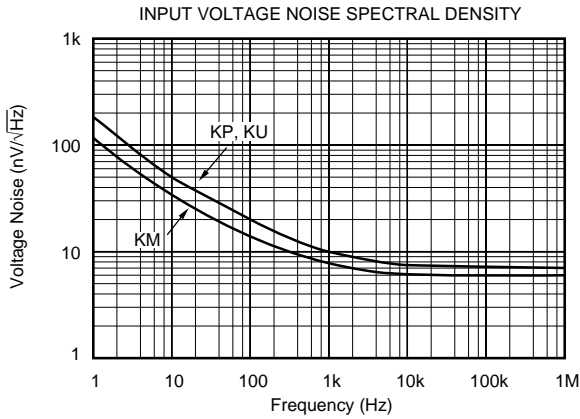

TYPICAL PERFORMANCE CURVES (CONT)

$T_A = +25^\circ\text{C}$, $V_{CC} = \pm 15\text{VDC}$ unless otherwise noted.

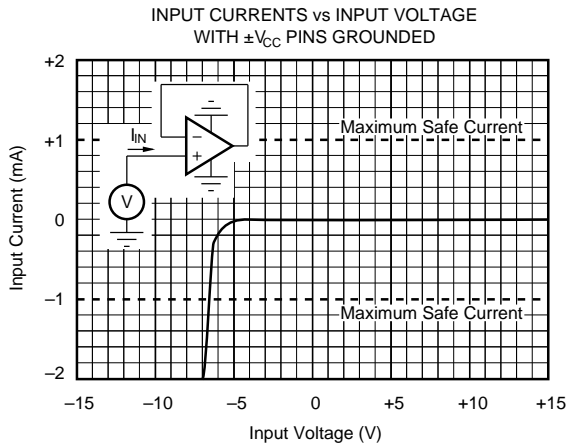
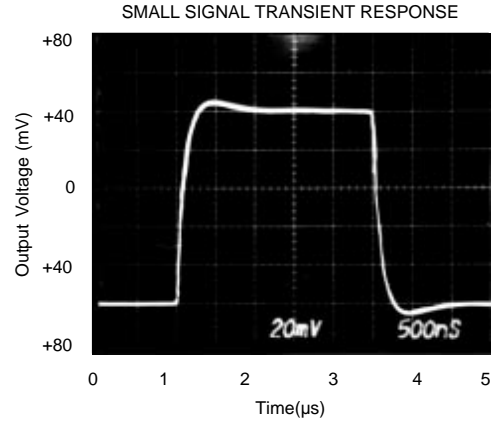
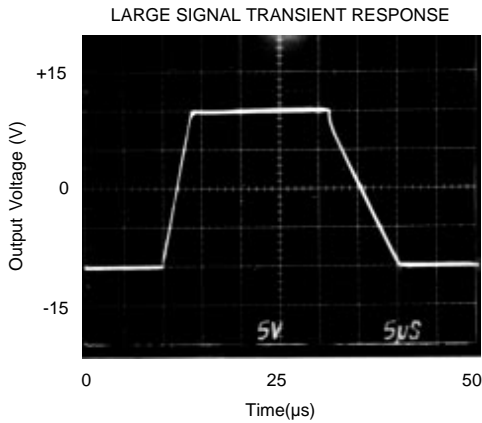

APPLICATIONS INFORMATION

OFFSET VOLTAGE ADJUSTMENT

The OPA121 offset voltage is laser-trimmed and will require no further trim for most applications. As with most amplifiers, externally trimming the remaining offset can change drift performance by about $0.3\mu\text{V}/^\circ\text{C}$ for each $100\mu\text{V}$ of adjusted offset. Note that the trim (Figure 1) is similar to operational amplifiers such as 741 and AD547. The OPA121 can replace most BIFET amplifiers by leaving the external null circuit unconnected.

INPUT PROTECTION

Conventional monolithic FET operational amplifiers require external current-limiting resistors to protect their inputs against destructive currents that can flow when input FET gate-to-substrate isolation diodes are forward-biased. Most BIFET amplifiers can be destroyed by the loss of $-V_{CC}$.

Unlike BIFET amplifiers, the *Difet* OPA121 requires input current limiting resistors only if its input voltage is greater

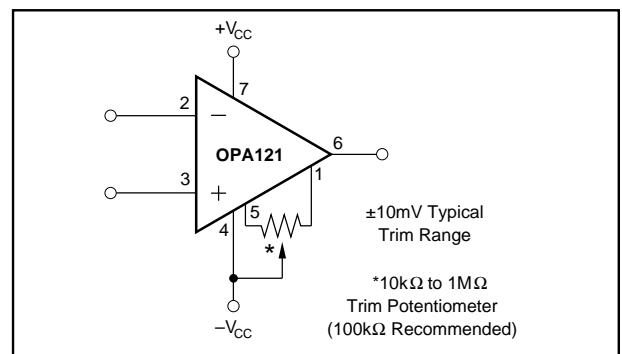

FIGURE 1. Offset Voltage Trim.

than 6V more negative than $-V_{CC}$. A $10\text{k}\Omega$ series resistor will limit input current to a safe level with up to $\pm 15\text{V}$ input levels even if both supply voltages are lost.

Static damage can cause subtle changes in amplifier input characteristics without necessarily destroying the device. In precision operational amplifiers (both bipolar and FET types),

this may cause a noticeable degradation of offset voltage and drift.

Static protection is recommended when handling any precision IC operational amplifier.

GUARDING AND SHIELDING

As in any situation where high impedances are involved, careful shielding is required to reduce “hum” pickup in input leads. If large feedback resistors are used, they should also be shielded along with the external input circuitry.

Leakage currents across printed circuit boards can easily exceed the bias current of the OPA121. To avoid leakage problems, it is recommended that the signal input lead of the OPA121 be wired to a Teflon™ standoff. If the OPA121 is to be soldered directly into a printed circuit board, utmost care must be used in planning the board layout. A “guard” pattern should completely surround the high-impedance input leads and should be connected to a low-impedance point which is at the signal input potential.

The amplifier case should be connected to any input shield or guard via pin 8. This insures that the amplifier itself is fully surrounded by guard potential, minimizing both leakage and noise pickup (see Figure #2).

If guarding is not required, pin 8 (case) should be connected to ground.

BIAS CURRENT CHANGE VERSUS COMMON-MODE VOLTAGE

The input bias currents of most popular BIFET operational amplifiers are affected by common-mode voltage (Figure 3). Higher input FET gate-to-drain voltage causes leakage and ionization (bias) currents to increase. Due to its cascode input stage, the extremely-low bias current of the OPA121 is not compromised by common-mode voltage.

Teflon™ E.I. du Pont de Nemours & Co.

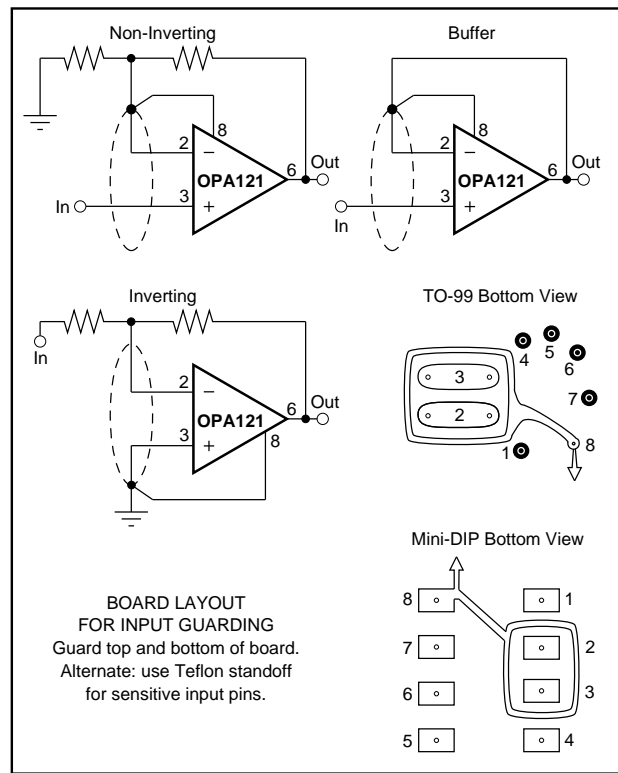

FIGURE 2. Connection of Input Guard.

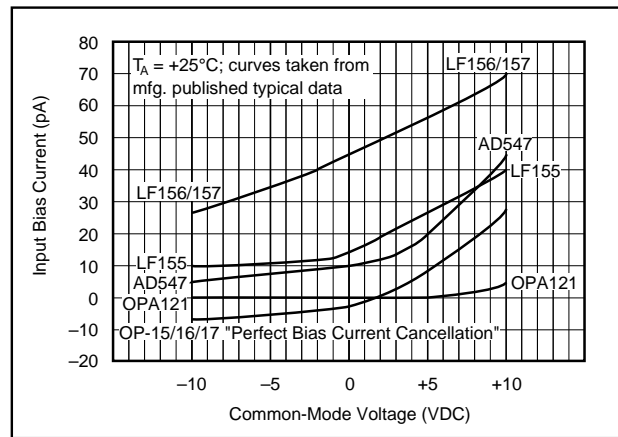

FIGURE 3. Input Bias Current vs Common-Mode Voltage.

IMPORTANT NOTICE

Texas Instruments and its subsidiaries (TI) reserve the right to make changes to their products or to discontinue any product or service without notice, and advise customers to obtain the latest version of relevant information to verify, before placing orders, that information being relied on is current and complete. All products are sold subject to the terms and conditions of sale supplied at the time of order acknowledgment, including those pertaining to warranty, patent infringement, and limitation of liability.

TI warrants performance of its semiconductor products to the specifications applicable at the time of sale in accordance with TI's standard warranty. Testing and other quality control techniques are utilized to the extent TI deems necessary to support this warranty. Specific testing of all parameters of each device is not necessarily performed, except those mandated by government requirements.

Customers are responsible for their applications using TI components.

In order to minimize risks associated with the customer's applications, adequate design and operating safeguards must be provided by the customer to minimize inherent or procedural hazards.

TI assumes no liability for applications assistance or customer product design. TI does not warrant or represent that any license, either express or implied, is granted under any patent right, copyright, mask work right, or other intellectual property right of TI covering or relating to any combination, machine, or process in which such semiconductor products or services might be or are used. TI's publication of information regarding any third party's products or services does not constitute TI's approval, warranty or endorsement thereof.