

SBOS093C – MARCH 1999 – REVISED SEPTEMBER 2002

# High-Voltage, High-Current OPERATIONAL AMPLIFIER

## FEATURES

- **HIGH OUTPUT CURRENT:**  
8A Continuous  
10A Peak
- **WIDE POWER-SUPPLY RANGE:**  
Single Supply: +8V to +60V  
Dual Supply:  $\pm 4V$  to  $\pm 30V$
- **WIDE OUTPUT VOLTAGE SWING**
- **FULLY PROTECTED:**  
Thermal Shutdown  
Adjustable Current Limit
- **OUTPUT DISABLE CONTROL**
- **THERMAL SHUTDOWN INDICATOR**
- **HIGH SLEW RATE: 9V/ $\mu s$**
- **CONTROL REFERENCE PIN**
- **11-LEAD POWER PACKAGE**

## APPLICATIONS

- VALVE, ACTUATOR DRIVER
- SYNCHRO, SERVO DRIVER
- POWER SUPPLIES
- TEST EQUIPMENT
- TRANSDUCER EXCITATION
- AUDIO POWER AMPLIFIER

## DESCRIPTION

The OPA549 is a low-cost, high-voltage/high-current operational amplifier ideal for driving a wide variety of loads. This laser-trimmed monolithic integrated circuit provides excellent low-level signal accuracy and high output voltage and current.

The OPA549 operates from either single or dual supplies for design flexibility. The input common-mode range extends below the negative supply.

The OPA549 is internally protected against over-temperature conditions and current overloads. In addition, the OPA549 provides an accurate, user-selected current limit. Unlike other designs which use a "power" resistor in series with the output current path, the OPA549 senses the load indirectly. This allows the current limit to be adjusted from 0A to 10A with a resistor/potentiometer, or controlled digitally with a voltage-out or current-out Digital-to-Analog Converter (DAC).

The Enable/Status (E/S) pin provides two functions. It can be monitored to determine if the device is in thermal shutdown, and it can be forced low to disable the output stage and effectively disconnect the load.

The OPA549 is available in an 11-lead power package. Its copper tab allows easy mounting to a heat sink for excellent thermal performance. Operation is specified over the extended industrial temperature range,  $-40^{\circ}C$  to  $+85^{\circ}C$ .

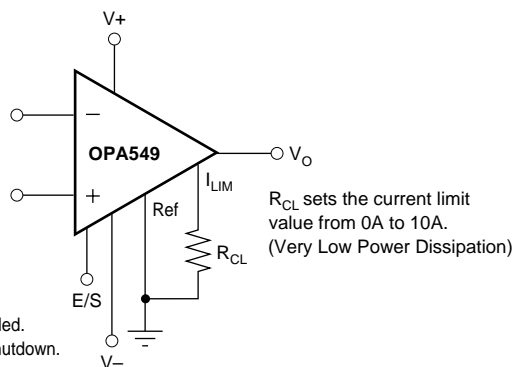

**E/S Pin.**  
Forced Low: Output disabled.  
Indicates Low: Thermal shutdown.



Please be aware that an important notice concerning availability, standard warranty, and use in critical applications of Texas Instruments semiconductor products and disclaimers thereto appears at the end of this data sheet.

## ABSOLUTE MAXIMUM RATINGS<sup>(1)</sup>

Output Current .....	See SOA Curve (Figure 6)
Supply Voltage, V+ to V- .....	60V
Input Voltage Range .....	(V-) - 0.5V to (V+) + 0.5V
Input Shutdown Voltage .....	Ref - 0.5 to V+
Operating Temperature .....	-40°C to +125°C
Storage Temperature .....	-55°C to +125°C
Junction Temperature .....	150°C
Lead Temperature (soldering, 10s) .....	300°C
ESD Capability (Human Body Model) .....	2000V

NOTE: (1) Stresses above these ratings may cause permanent damage. Exposure to absolute maximum conditions for extended periods may degrade device reliability.



## ELECTROSTATIC DISCHARGE SENSITIVITY

This integrated circuit can be damaged by ESD. Texas Instruments recommends that all integrated circuits be handled with appropriate precautions. Failure to observe proper handling and installation procedures can cause damage.

ESD damage can range from subtle performance degradation to complete device failure. Precision integrated circuits may be more susceptible to damage because very small parametric changes could cause the device not to meet its published specifications.

## PACKAGE/ORDERING INFORMATION

PRODUCT	PACKAGE-LEAD	PACKAGE DESIGNATOR <sup>(1)</sup>	SPECIFIED TEMPERATURE RANGE	PACKAGE MARKING	ORDERING NUMBER	TRANSPORT MEDIA, QUANTITY
OPA549	11-Lead Power ZIP	KV	-40°C to +85°C	OPA549T	OPA549T	Rails, 25
OPA549	11-Lead Power	KVC	"	OPA549S	OPA549S	Rails, 25

NOTE: (1) For the most current specifications and package information, refer to our web site at [www.ti.com](http://www.ti.com).

## CONNECTION DIAGRAM

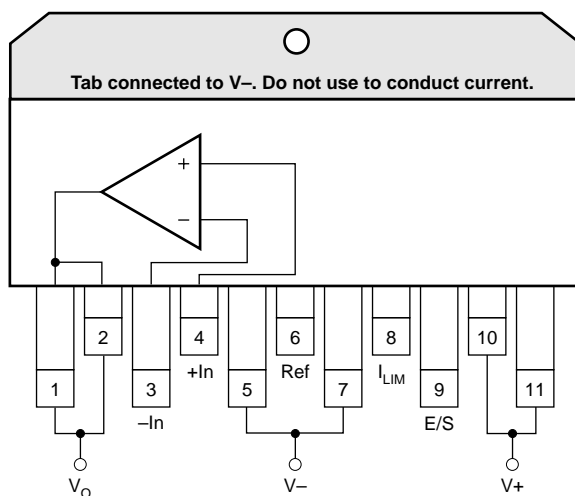

Connect both pins 1 and 2 to output.  
 Connect both pins 5 and 7 to V-.  
 Connect both pins 10 and 11 to V+.



# TYPICAL CHARACTERISTICS

At  $T_{CASE} = +25^{\circ}C$ ,  $V_S = \pm 30V$ , and E/S pin open, unless otherwise noted.

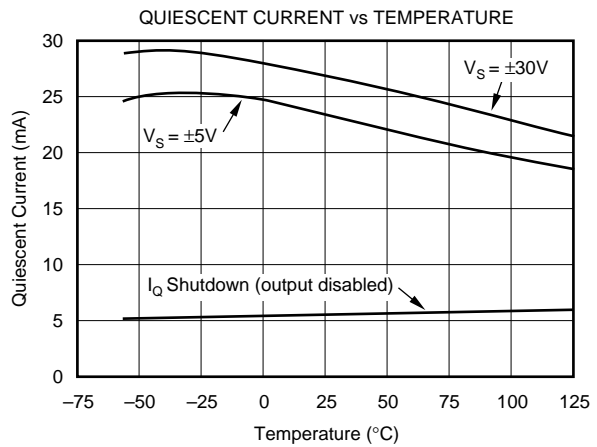
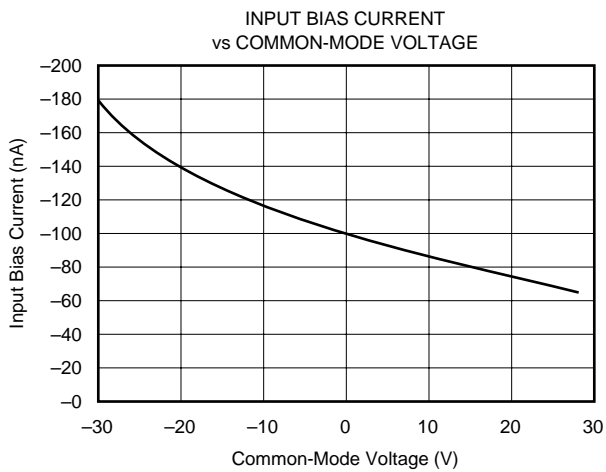
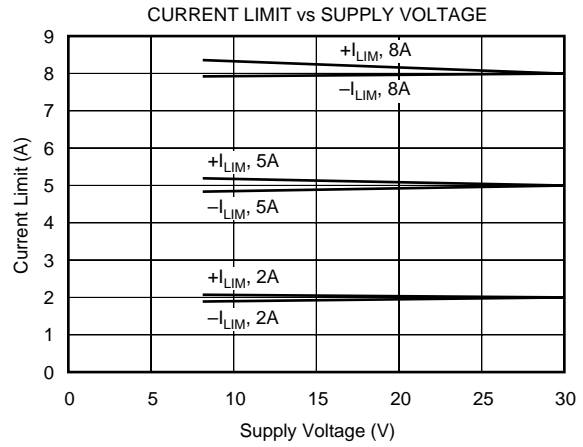
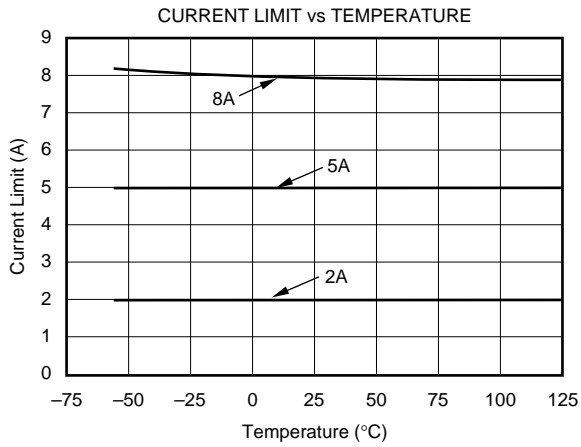
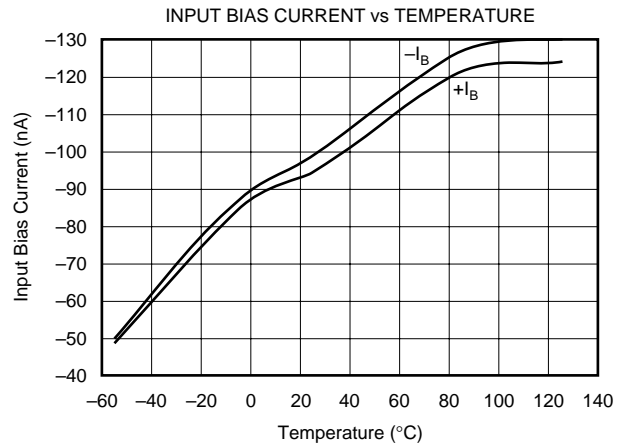
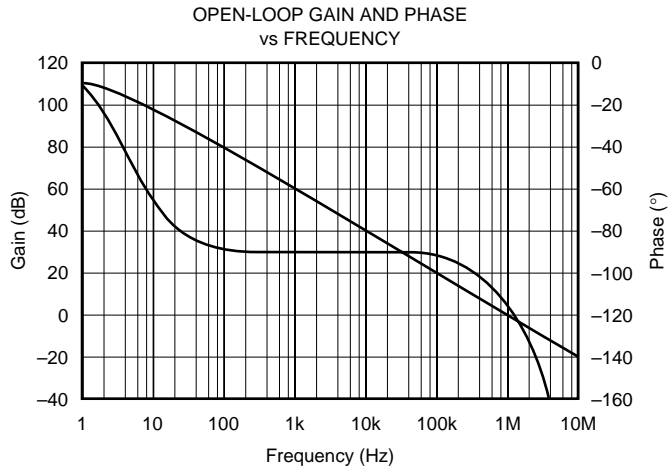

# TYPICAL CHARACTERISTICS (Cont.)

At  $T_{CASE} = +25^{\circ}C$ ,  $V_S = \pm 30V$ , and E/S pin open, unless otherwise noted.

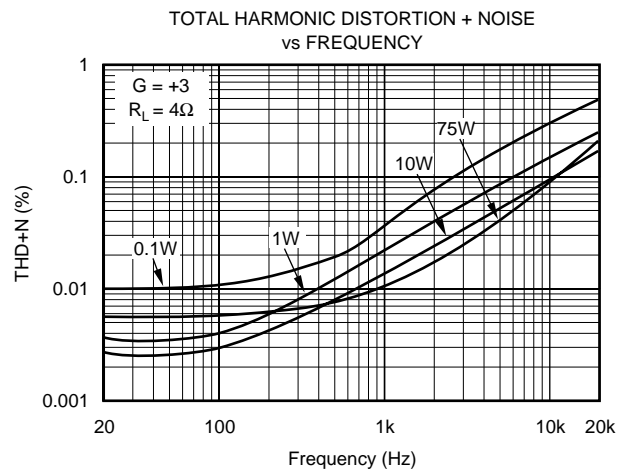
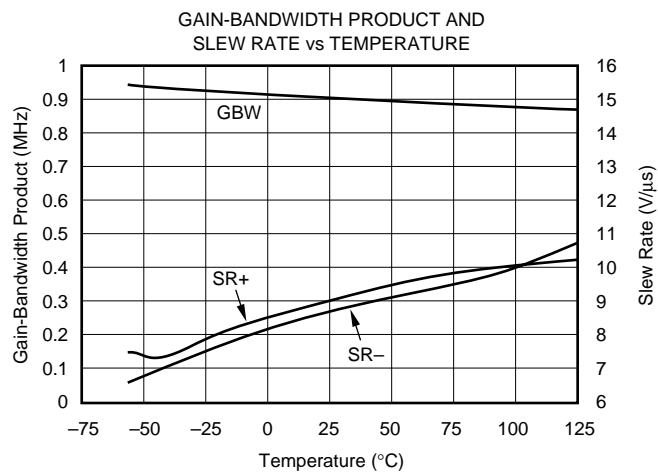
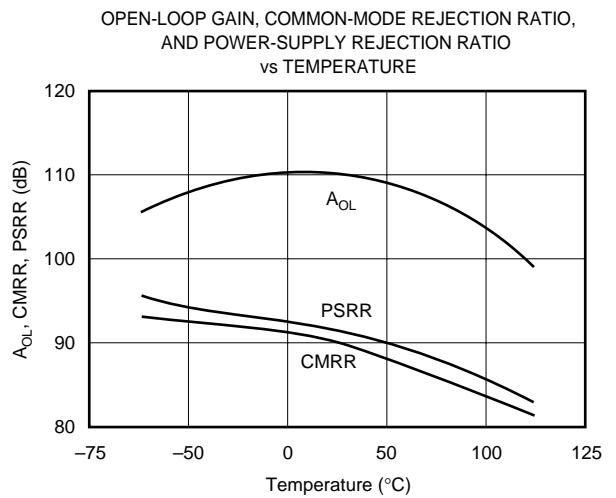
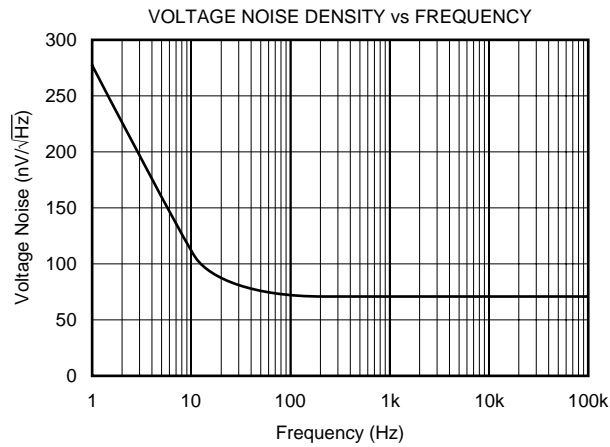
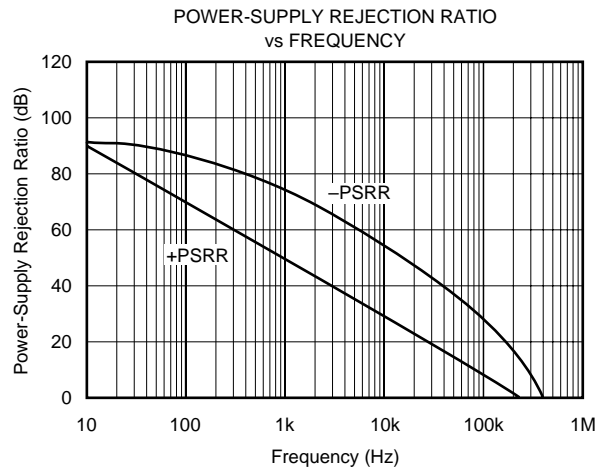
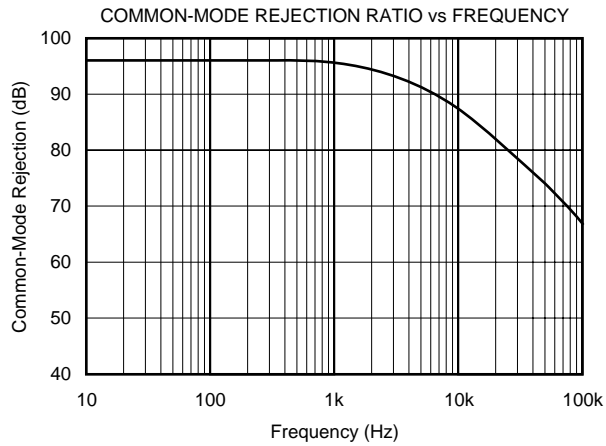

# TYPICAL CHARACTERISTICS (Cont.)

At  $T_{CASE} = +25^{\circ}C$ ,  $V_S = \pm 30V$ , and E/S pin open, unless otherwise noted.

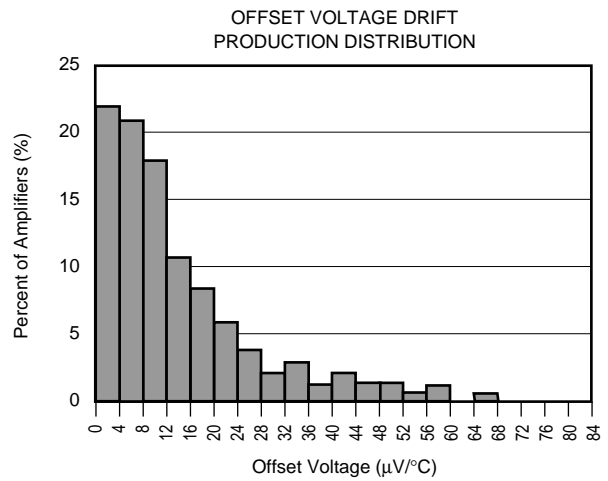
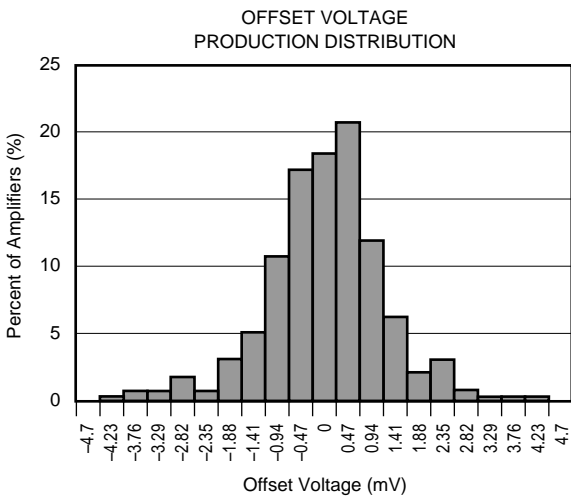
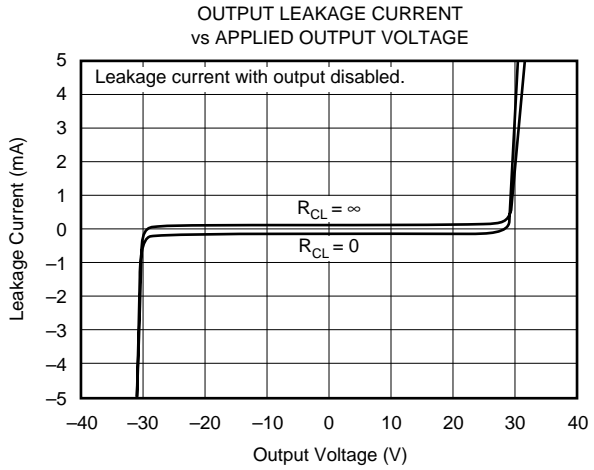
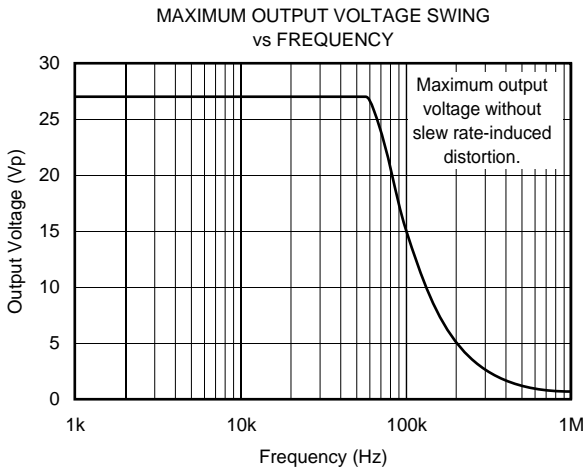
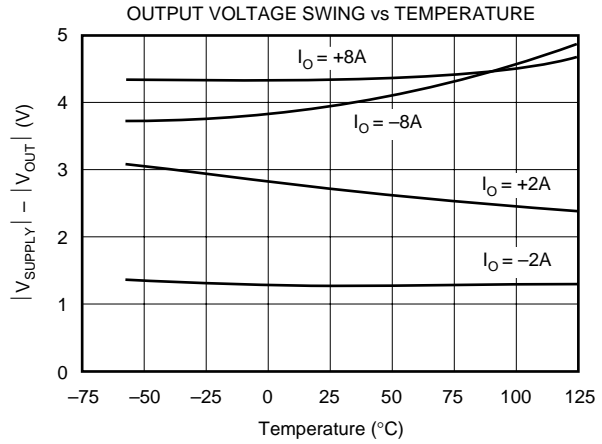
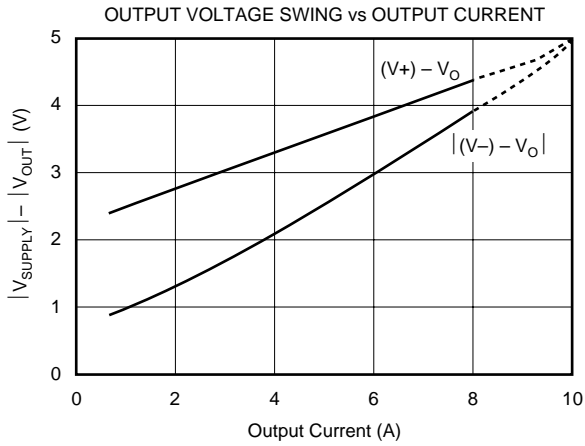

# TYPICAL CHARACTERISTICS (Cont.)

At  $T_{CASE} = +25^{\circ}C$ ,  $V_S = \pm 30V$ , and E/S pin open, unless otherwise noted.

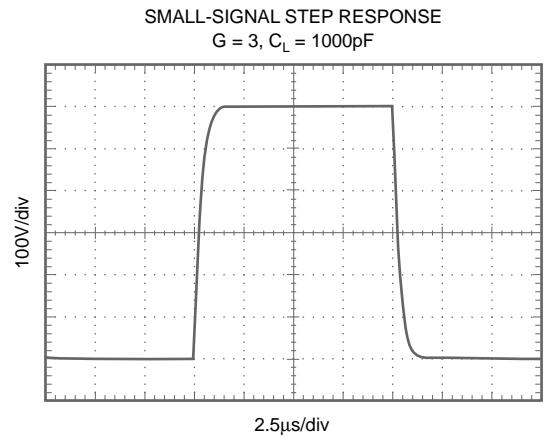
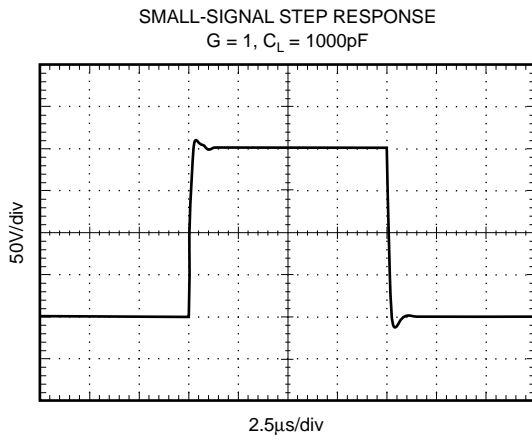
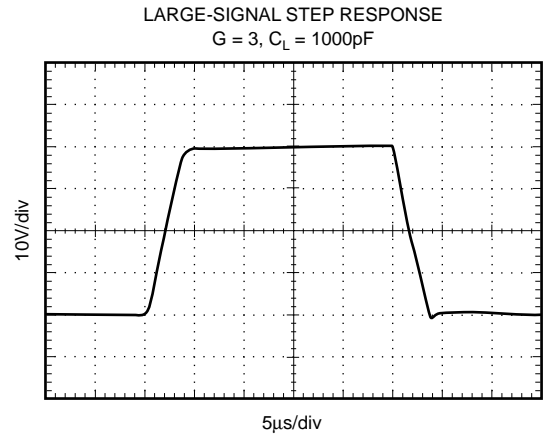
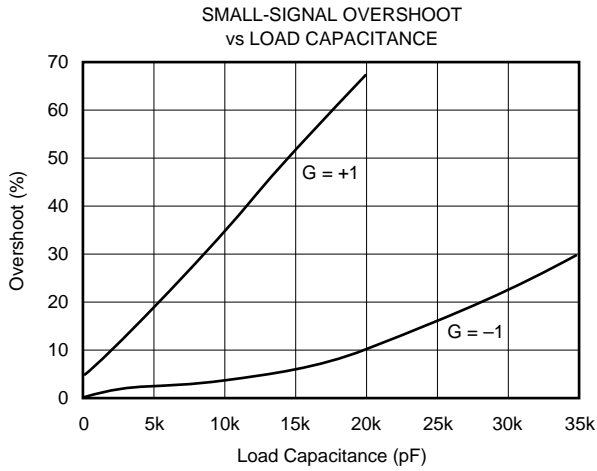

# APPLICATIONS INFORMATION

Figure 1 shows the OPA549 connected as a basic noninverting amplifier. The OPA549 can be used in virtually any op amp configuration.

Power-supply terminals should be bypassed with low series impedance capacitors. The technique shown in Figure 1, using a ceramic and tantalum type in parallel, is recommended. Power-supply wiring should have low series impedance.

Be sure to connect *both* output pins (pins 1 and 2).

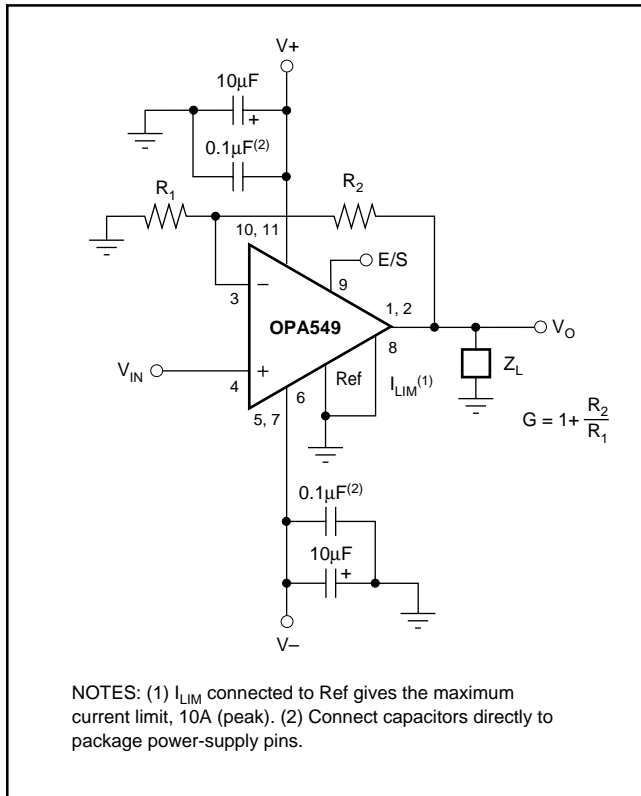

FIGURE 1. Basic Circuit Connections.

## POWER SUPPLIES

The OPA549 operates from single (+8V to +60V) or dual ( $\pm 4V$  to  $\pm 30V$ ) supplies with excellent performance. Most behavior remains unchanged throughout the full operating voltage range. Parameters that vary significantly with operating voltage are shown in the Typical Characteristics. Some applications do not require equal positive and negative output voltage swing. Power-supply voltages do not need to be equal. The OPA549 can operate with as little as 8V between the supplies and with up to 60V between the supplies. For example, the positive supply could be set to 55V with the negative supply at  $-5V$ . **Be sure to connect both V- pins (pins 5 and 7) to the negative power supply and both V+ pins (pins 10 and 11) to the positive power supply. Package tab is internally connected to V-, however, do use the tab to conduct current.**

## CONTROL REFERENCE (Ref) PIN

The OPA549 features a reference (Ref) pin to which the  $I_{LIM}$  and the E/S pin are referred. Ref simply provides a reference point accessible to the user that can be set to  $V-$ , ground, or any reference of the user's choice. **Ref cannot be set below the negative supply or above  $(V+) - 8V$ . If the minimum  $V_S$  is used, Ref must be set at  $V-$ .**

## ADJUSTABLE CURRENT LIMIT

The OPA549's accurate, user-defined current limit can be set from 0A to 10A by controlling the input to the  $I_{LIM}$  pin. Unlike other designs, which use a power resistor in series with the output current path, the OPA549 senses the load indirectly. This allows the current limit to be set with a  $0\mu A$  to  $633\mu A$  control signal. In contrast, other designs require a limiting resistor to handle the full output current (up to 10A in this case).

Although the design of the OPA549 allows output currents up to 10A, it is not recommended that the device be operated continuously at that level. The highest rated continuous current capability is 8A. Continuously running the OPA549 at output currents greater than 8A will degrade long-term reliability.

Operation of the OPA549 with current limit less than 1A results in reduced current limit accuracy. Applications requiring lower output current may be better suited to the OPA547 or OPA548.

## Resistor-Controlled Current Limit

See Figure 2a for a simplified schematic of the internal circuitry used to set the current limit. Leaving the  $I_{LIM}$  pin open programs the output current to zero, while connecting  $I_{LIM}$  directly to Ref programs the maximum output current limit, typically 10A.

With the OPA549, the simplest method for adjusting the current limit uses a resistor or potentiometer connected between the  $I_{LIM}$  pin and Ref according to Equation 1:

$$R_{CL} = \frac{75kV}{I_{LIM}} - 7.5k\Omega \quad (1)$$

Refer to Figure 2 for commonly used values.

## Digitally-Controlled Current Limit

The low-level control signal ( $0\mu A$  to  $633\mu A$ ) also allows the current limit to be digitally controlled by setting either a current ( $I_{SET}$ ) or voltage ( $V_{SET}$ ). The output current  $I_{LIM}$  can be adjusted by varying  $I_{SET}$  according to Equation 2:

$$I_{SET} = I_{LIM}/15800 \quad (2)$$

Figure 2b demonstrates a circuit configuration implementing this feature.

The output current  $I_{LIM}$  can be adjusted by varying  $V_{SET}$  according to Equation 3:

$$V_{SET} = (\text{Ref}) + 4.75V - (7500W)(I_{LIM})/15800 \quad (3)$$

Figure 11 demonstrates a circuit configuration implementing this feature.

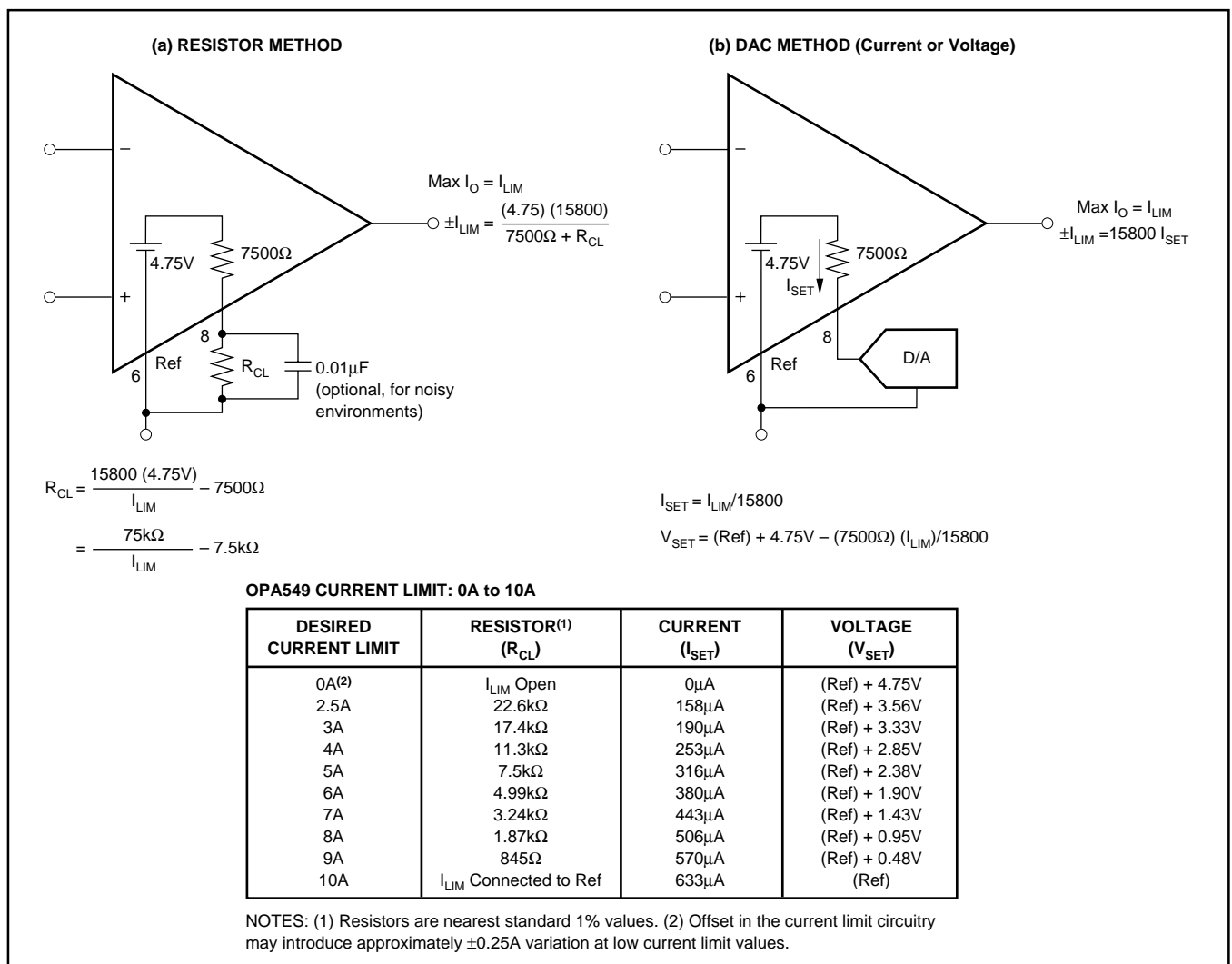

FIGURE 2. Adjustable Current Limit.

### ENABLE/STATUS (E/S) PIN

The Enable/Status Pin provides two unique functions: 1) output disable by forcing the pin low, and 2) thermal shutdown indication by monitoring the voltage level at the pin. Either or both of these functions can be utilized in an application. For normal operation (output enabled), the E/S pin can be left open or driven high (at least 2.4V above Ref). A small value capacitor connected between the E/S pin and C<sub>REF</sub> may be required for noisy applications.

#### Output Disable

To disable the output, the E/S pin is pulled to a logic low (no greater than 0.8V above Ref). Typically the output is shut down in 1μs. To return the output to an enabled state, the E/S pin should be disconnected (open) or pulled to at least 2.4V above Ref. It should be noted that driving the E/S pin high (output enabled) *does not defeat internal thermal shutdown*; however, it does prevent the user from monitoring the thermal shutdown status. Figure 3 shows an example implementing this function.

This function not only conserves power during idle periods (quiescent current drops to approximately 6mA) but also allows multiplexing in multi-channel applications. See Figure 12 for two

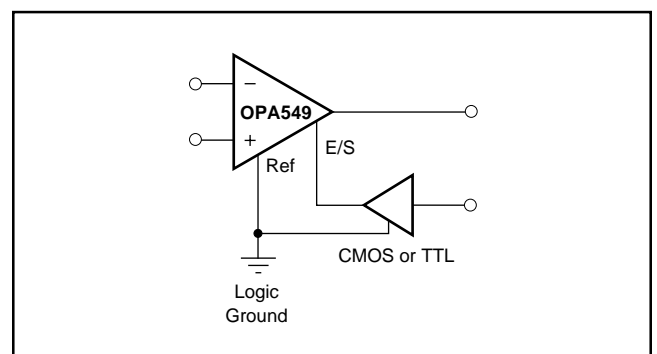

FIGURE 3. Output Disable.

OPA549s in a switched amplifier configuration. The on/off state of the two amplifiers is controlled by the voltage on the E/S pin. Under these conditions, the disabled device will behave like a 750pF load. Slewing faster than 3V/μs will cause leakage current to rapidly increase in devices that are disabled, and will contribute additional load. At high temperature (125°C), the slewing threshold drops to approximately 2V/μs. Input signals must be limited to avoid excessive slewing in multiplexed applications.

## Thermal Shutdown Status

The OPA549 has thermal shutdown circuitry that protects the amplifier from damage. The thermal protection circuitry disables the output when the junction temperature reaches approximately 160°C and allows the device to cool. When the junction temperature cools to approximately 140°C, the output circuitry is automatically re-enabled. Depending on load and signal conditions, the thermal protection circuit may cycle on and off. The E/S pin can be monitored to determine if the device is in shutdown. During normal operation, the voltage on the E/S pin is typically 3.5V above Ref. Once shutdown has occurred, this voltage drops to approximately 200mV above Ref. Figure 4 shows an example implementing this function.

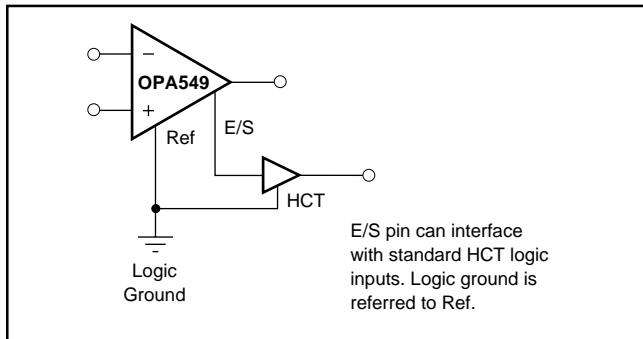

FIGURE 4. Thermal Shutdown Status.

External logic circuitry or an LED can be used to indicate if the output has been thermally shutdown, see Figure 10.

## Output Disable and Thermal Shutdown Status

As mentioned earlier, the OPA549's output can be disabled and the disable status can be monitored simultaneously. Figure 5 provides an example of interfacing to the E/S pin.

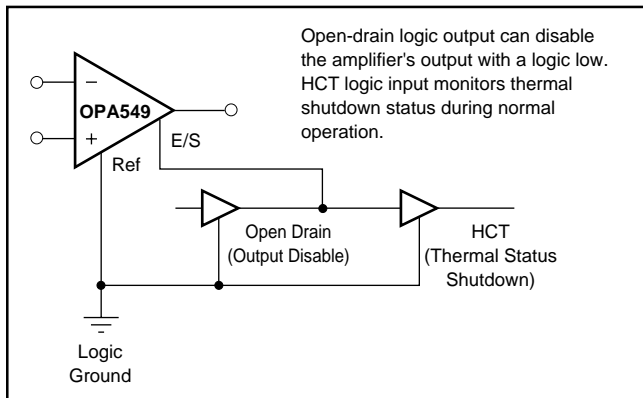

FIGURE 5. Output Disable and Thermal Shutdown Status.

## SAFE OPERATING AREA

Stress on the output transistors is determined both by the output current and by the output voltage across the conducting output transistor,  $V_S - V_O$ . The power dissipated by the output transistor is equal to the product of the output current and the voltage across the conducting transistor,  $V_S - V_O$ .

The Safe Operating Area (SOA curve, Figure 6) shows the permissible range of voltage and current.

The safe output current decreases as  $V_S - V_O$  increases. Output short circuits are a very demanding case for SOA. A short circuit to ground forces the full power-supply voltage ( $V_+$  or  $V_-$ ) across the conducting transistor. Increasing the case temperature reduces the safe output current that can be tolerated without activating the thermal shutdown circuit of the OPA549. For further insight on SOA, consult Application Report SBOA022 at the Texas Instruments web site ([www.ti.com](http://www.ti.com)).

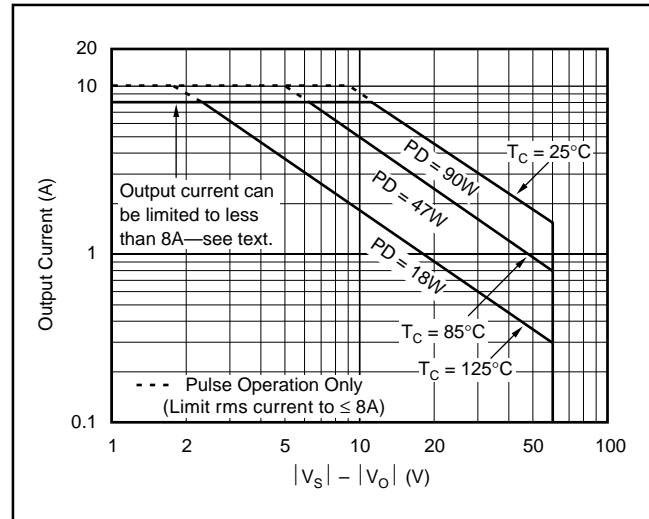

FIGURE 6. Safe Operating Area.

## POWER DISSIPATION

Power dissipation depends on power supply, signal, and load conditions. For dc signals, power dissipation is equal to the product of output current times the voltage across the conducting output transistor. Power dissipation can be minimized by using the lowest possible power-supply voltage necessary to assure the required output voltage swing.

For resistive loads, the maximum power dissipation occurs at a dc output voltage of one-half the power-supply voltage. Dissipation with ac signals is lower. Application Bulletin SBOA022 explains how to calculate or measure power dissipation with unusual signals and loads.

## THERMAL PROTECTION

Power dissipated in the OPA549 will cause the junction temperature to rise. Internal thermal shutdown circuitry shuts down the output when the die temperature reaches approximately 160°C and resets when the die has cooled to 140°C. Depending on load and signal conditions, the thermal protection circuit may cycle on and off. This limits the dissipation of the amplifier but may have an undesirable effect on the load.

Any tendency to activate the thermal protection circuit indicates excessive power dissipation or an inadequate heat sink. For reliable operation, junction temperature should be limited to 125°C maximum. To estimate the margin of safety

in a complete design (including heat sink) increase the ambient temperature until the thermal protection is triggered. Use worst-case load and signal conditions. For good reliability, thermal protection should trigger more than 35°C above the maximum expected ambient condition of your application. This produces a junction temperature of 125°C at the maximum expected ambient condition.

The internal protection circuitry of the OPA549 was designed to protect against overload conditions. It was not intended to replace proper heat sinking. Continuously running the OPA549 into thermal shutdown will degrade reliability.

## AMPLIFIER MOUNTING AND HEAT SINKING

Most applications require a heat sink to assure that the maximum operating junction temperature (125°C) is not exceeded. In addition, the junction temperature should be kept as low as possible for increased reliability. Junction temperature can be determined according to the Equations:

$$T_J = T_A + P_D \theta_{JA} \quad (4)$$

where  $\theta_{JA} = \theta_{JC} + \theta_{CH} + \theta_{HA}$  (5)

- $T_J$  = Junction Temperature (°C)
- $T_A$  = Ambient Temperature (°C)
- $P_D$  = Power Dissipated (W)
- $\theta_{JC}$  = Junction-to-Case Thermal Resistance (°C/W)
- $\theta_{CH}$  = Case-to-Heat Sink Thermal Resistance (°C/W)
- $\theta_{HA}$  = Heat Sink-to-Ambient Thermal Resistance (°C/W)
- $\theta_{JA}$  = Junction-to-Air Thermal Resistance (°C/W)

Figure 7 shows maximum power dissipation versus ambient temperature with and without the use of a heat sink. Using a heat sink significantly increases the maximum power dissipation at a given ambient temperature, as shown in Figure 7.

The challenge in selecting the heat sink required lies in determining the power dissipated by the OPA549. For dc output, power dissipation is simply the load current times the voltage developed across the conducting output transistor,  $P_D = I_L (V_S - V_O)$ . Other loads are not as simple. Consult the SBOA022 Application Report for further insight on calculating power dissipation. Once power dissipation for an application is known, the proper heat sink can be selected.

**Heat Sink Selection Example**—An 11-lead power ZIP package is dissipating 10 Watts. The maximum expected ambient temperature is 40°C. Find the proper heat sink to keep the junction temperature below 125°C (150°C minus 25°C safety margin).

Combining Equations (4) and (5) gives:

$$T_J = T_A + P_D (\theta_{JC} + \theta_{CH} + \theta_{HA}) \quad (6)$$

$T_J$ ,  $T_A$ , and  $P_D$  are given.  $\theta_{JC}$  is provided in the Specifications Table, 1.4°C/W (dc).  $\theta_{CH}$  can be obtained from the heat sink manufacturer. Its value depends on heat sink size, area, and material used. Semiconductor package type, mounting screw torque, insulating material used (if any), and thermal joint

compound used (if any) also affect  $\theta_{CH}$ . A typical  $\theta_{CH}$  for a mounted 11-lead power ZIP package is 0.5°C/W. Now we can solve for  $\theta_{HA}$ :

$$\theta_{HA} = [(T_J - T_A)/P_D] - \theta_{JC} - \theta_{CH}$$

$$\theta_{HA} = [(125^\circ\text{C} - 40^\circ\text{C})/10\text{W}] - 1.4^\circ\text{C/W} - 0.5^\circ\text{C/W}$$

$$\theta_{HA} = 6.6^\circ\text{C/W}$$

To maintain junction temperature below 125°C, the heat sink selected must have a  $\theta_{HA}$  less than 6.6°C/W. In other words, the heat sink temperature rise above ambient must be less than 66°C (6.6°C/W • 10W). For example, at 10W Thermalloy model number 6396B has a heat sink temperature rise of 56°C ( $\theta_{HA} = 56^\circ\text{C}/10\text{W} = 5.6^\circ\text{C/W}$ ), which is below the required 66°C required in this example. Thermalloy model number 6399B has a sink temperature rise of 33°C ( $\theta_{HA} = 33^\circ\text{C}/10\text{W} = 3.3^\circ\text{C/W}$ ), which is also below the required 66°C required in this example. Figure 7 shows power dissipation versus ambient temperature for a 11-lead power ZIP package with the Thermalloy 6396B and 6399B heat sinks.

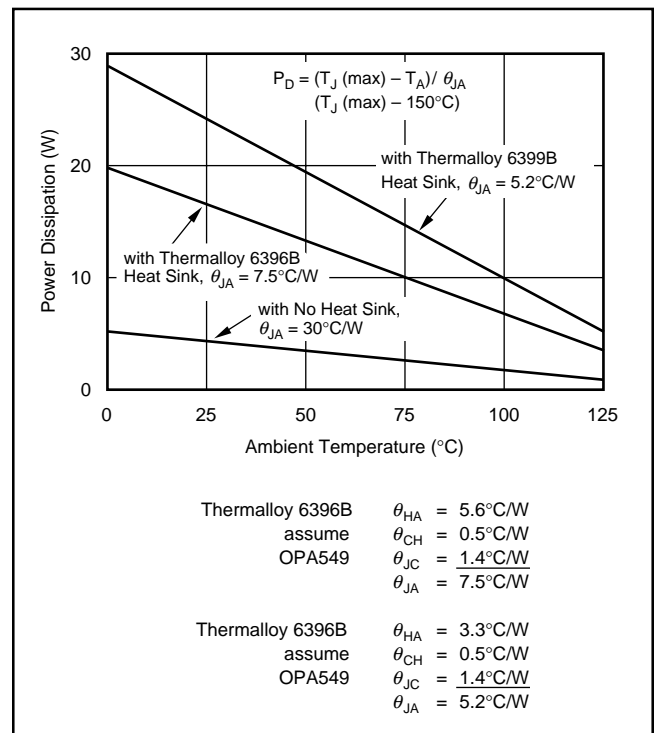

FIGURE 7. Maximum Power Dissipation vs Ambient Temperature.

Another variable to consider is natural convection versus forced convection air flow. Forced-air cooling by a small fan can lower  $\theta_{CA}$  ( $\theta_{CH} + \theta_{HA}$ ) dramatically. Some heat sink manufacturers provide thermal data for both of these cases. Heat sink performance is generally specified under idealized conditions that may be difficult to achieve in an actual application. For additional information on determining heat sink requirements, consult Application Report SBOA021.

As mentioned earlier, once a heat sink has been selected, the complete design should be tested under worst-case load and signal conditions to ensure proper thermal protection. Any tendency to activate the thermal protection circuitry may indicate inadequate heat sinking.

The tab of the 11-lead power ZIP package is electrically connected to the negative supply, V-. It may be desirable to isolate the tab of the 11-lead power ZIP package from its mounting surface with a mica (or other film) insulator. For lowest overall thermal resistance, it is best to isolate the entire heat sink/OPA549 structure from the mounting surface rather than to use an insulator between the semiconductor and heat sink.

### OUTPUT STAGE COMPENSATION

The complex load impedances common in power op amp applications can cause output stage instability. For normal operation, output compensation circuitry is typically not required. However, for difficult loads or if the OPA549 is intended to be driven into current limit, an R/C network may be required. Figure 8 shows an output R/C compensation (snubber) network which generally provides excellent stability.

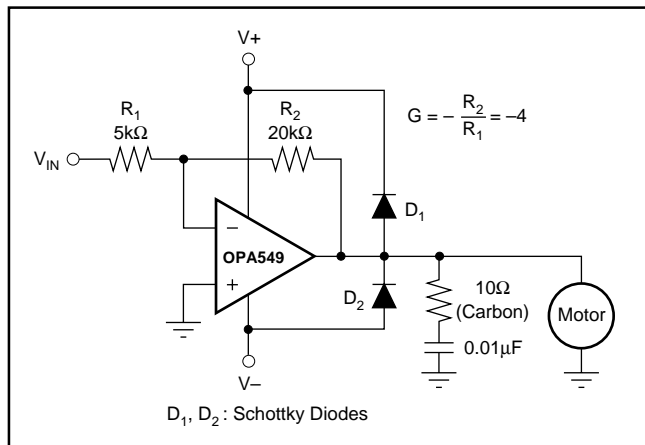

FIGURE 8. Motor Drive Circuit.

A snubber circuit may also enhance stability when driving large capacitive loads (> 1000pF) or inductive loads (motors, loads separated from the amplifier by long cables). Typically, 3Ω to 10Ω resistors in series with 0.01μF to 0.1μF capacitors is adequate. Some variations in circuit values may be required with certain loads.

### OUTPUT PROTECTION

Reactive and EMF-generating loads can return load current to the amplifier, causing the output voltage to exceed the power-supply voltage. This damaging condition can be

avoided with clamp diodes from the output terminal to the power supplies, as shown in Figure 8. Schottky rectifier diodes with a 8A or greater continuous rating are recommended.

### VOLTAGE SOURCE APPLICATION

Figure 9 illustrates how to use the OPA549 to provide an accurate voltage source with only three external resistors. First, the current limit resistor, R<sub>CL</sub>, is chosen according to the desired output current. The resulting voltage at the I<sub>LIM</sub> pin is constant and stable over temperature. This voltage, V<sub>CL</sub>, is connected to the noninverting input of the op amp and used as a voltage reference, thus eliminating the need for an external reference. The feedback resistors are selected to gain V<sub>CL</sub> to the desired output voltage level.

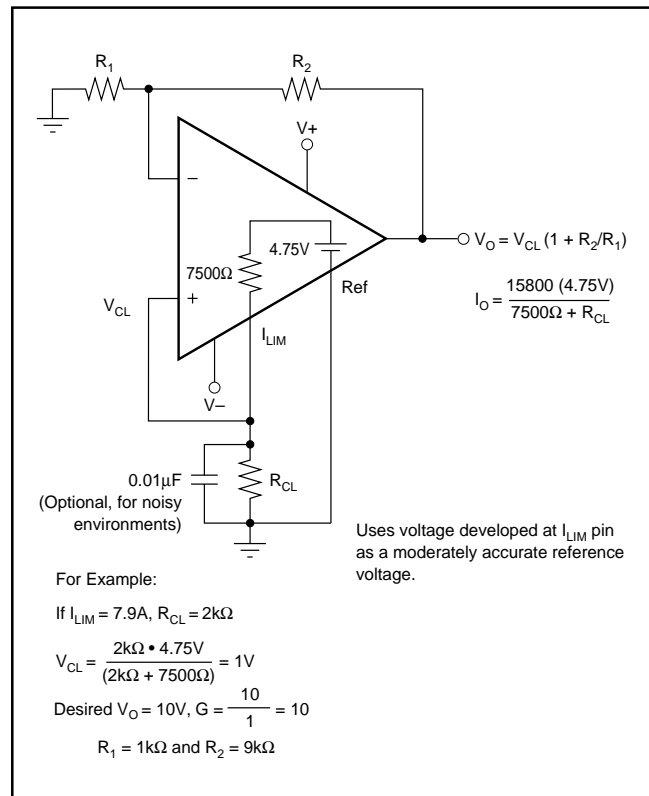

FIGURE 9. Voltage Source.

### PROGRAMMABLE POWER SUPPLY

A programmable source/sink power supply can easily be built using the OPA549. Both the output voltage and output current are user-controlled. See Figure 10 for a circuit using potentiometers to adjust the output voltage and current while Figure 11 uses DACs. An LED connected to the E/S pin through a logic gate indicates if the OPA549 is in thermal shutdown.

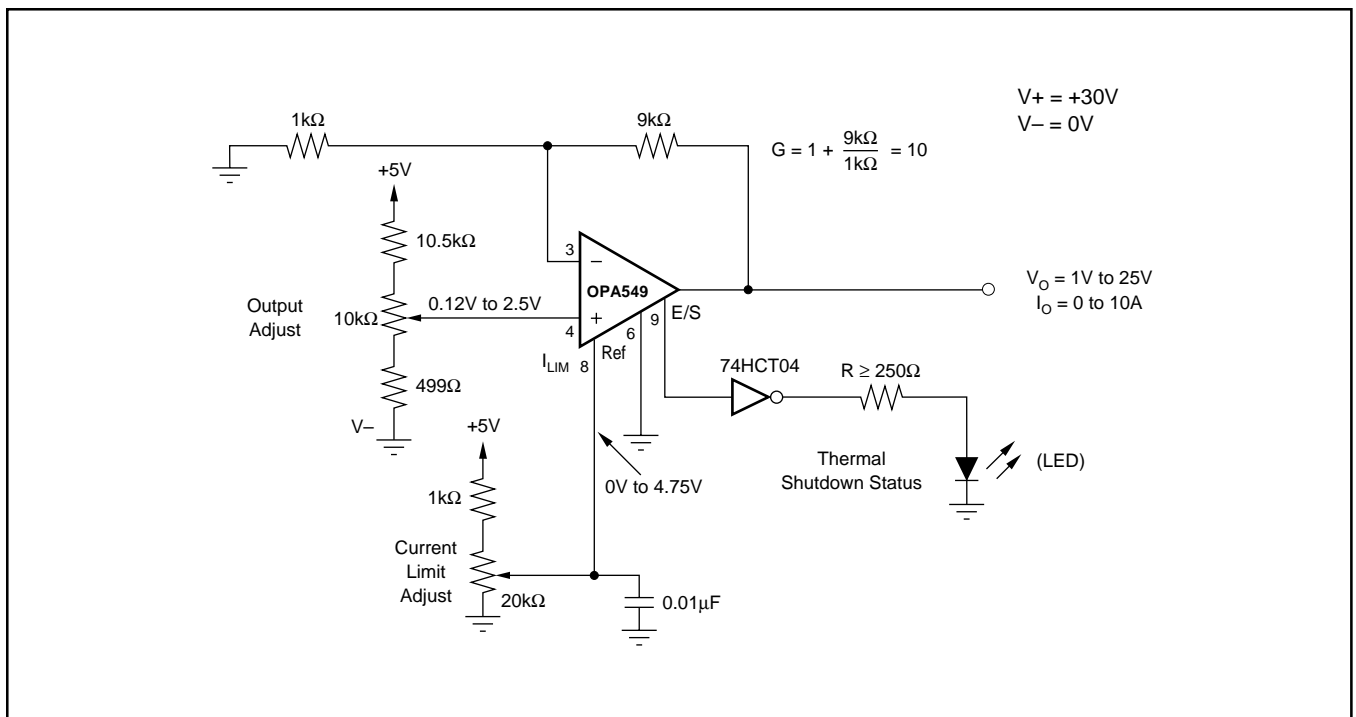

FIGURE 10. Resistor-Controlled Programmable Power Supply.

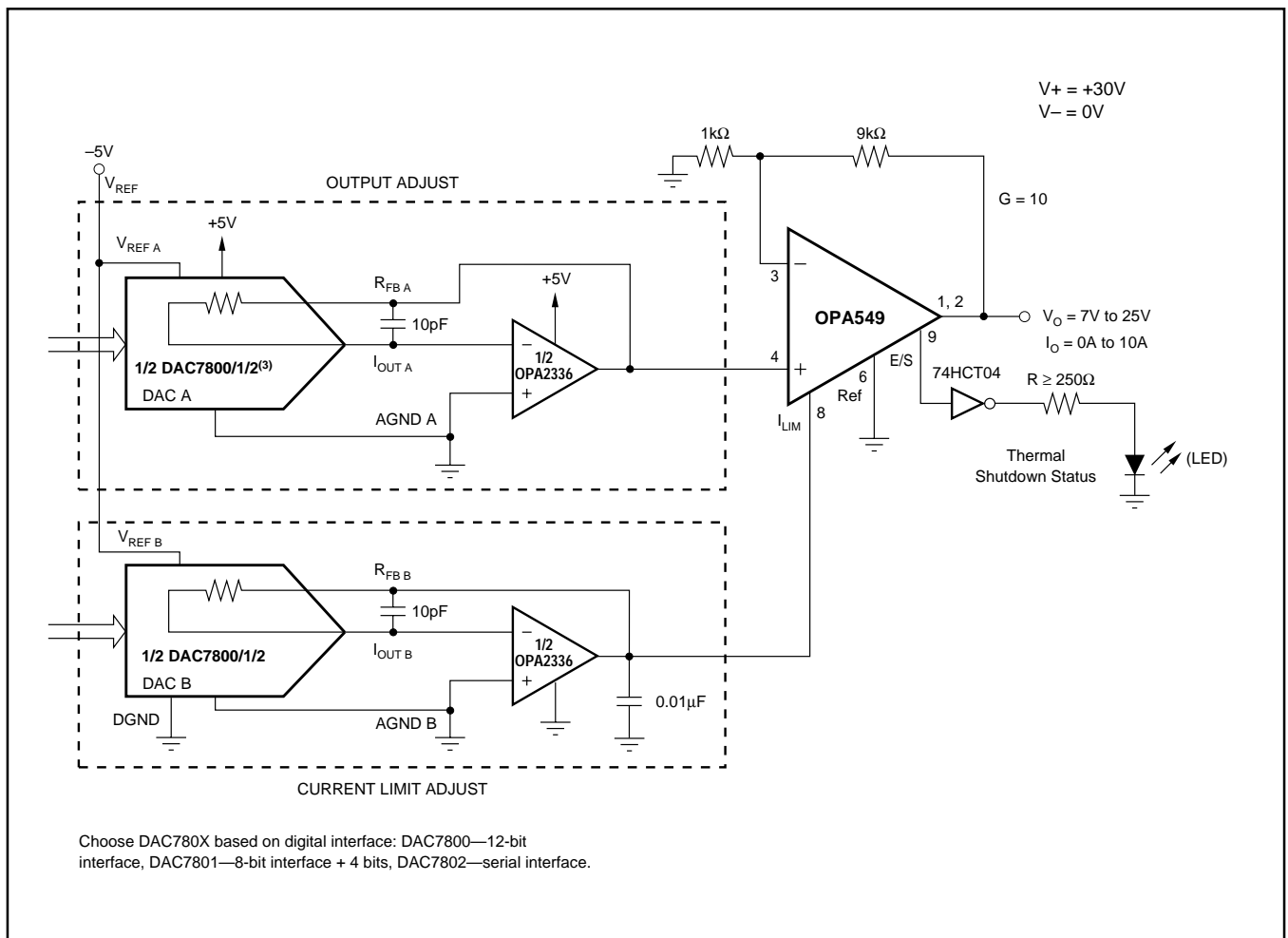

FIGURE 11. Digitally-Controlled Programmable Power Supply.

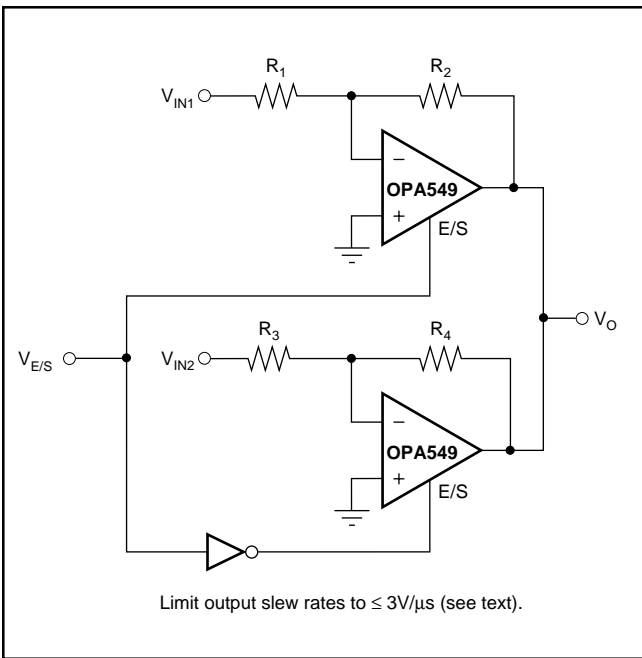

FIGURE 12. Switched Amplifier.

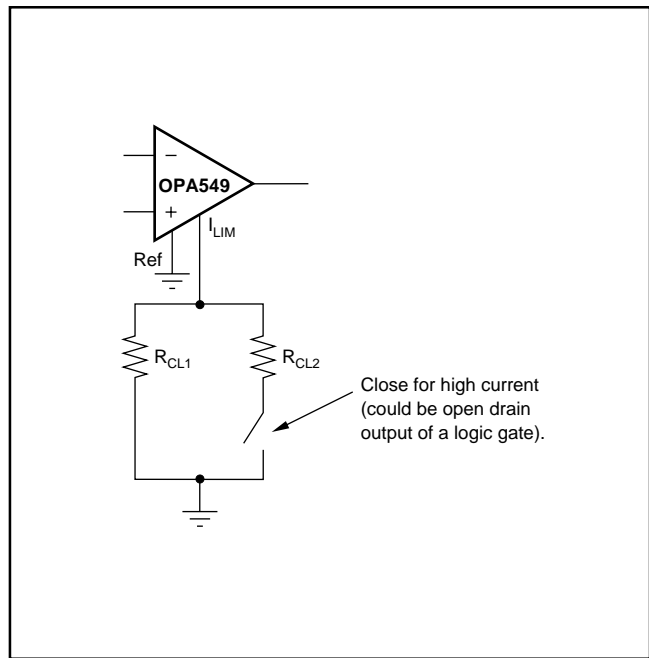

FIGURE 13. Multiple Current Limit Values.

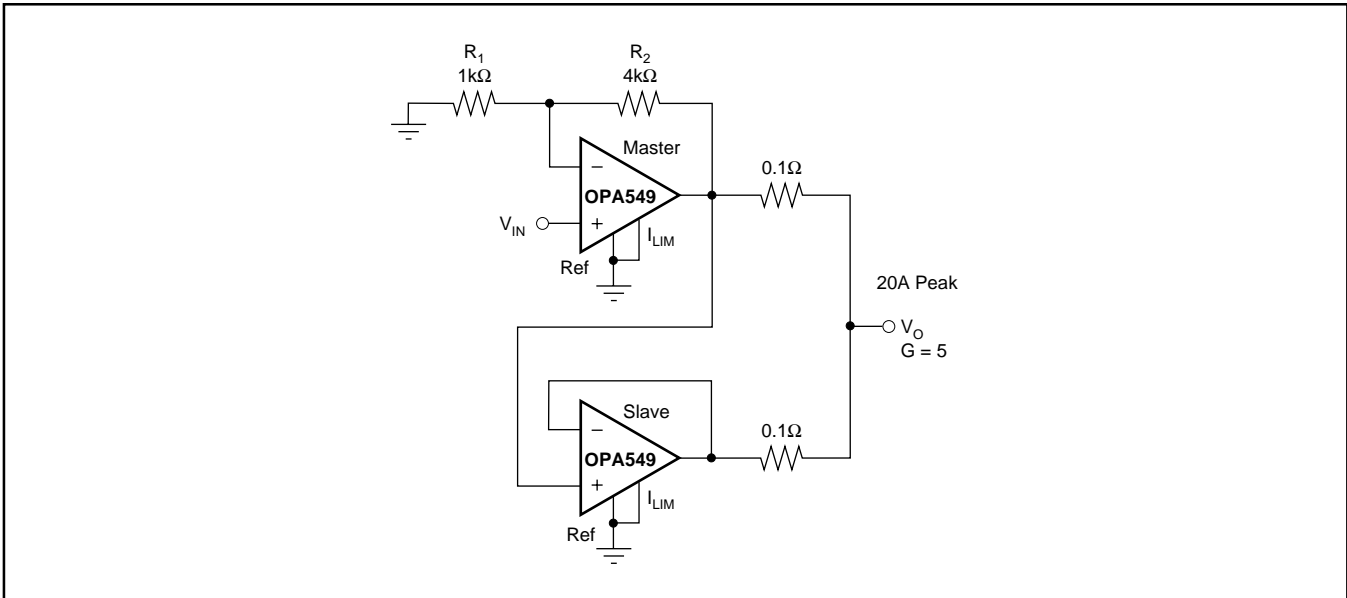
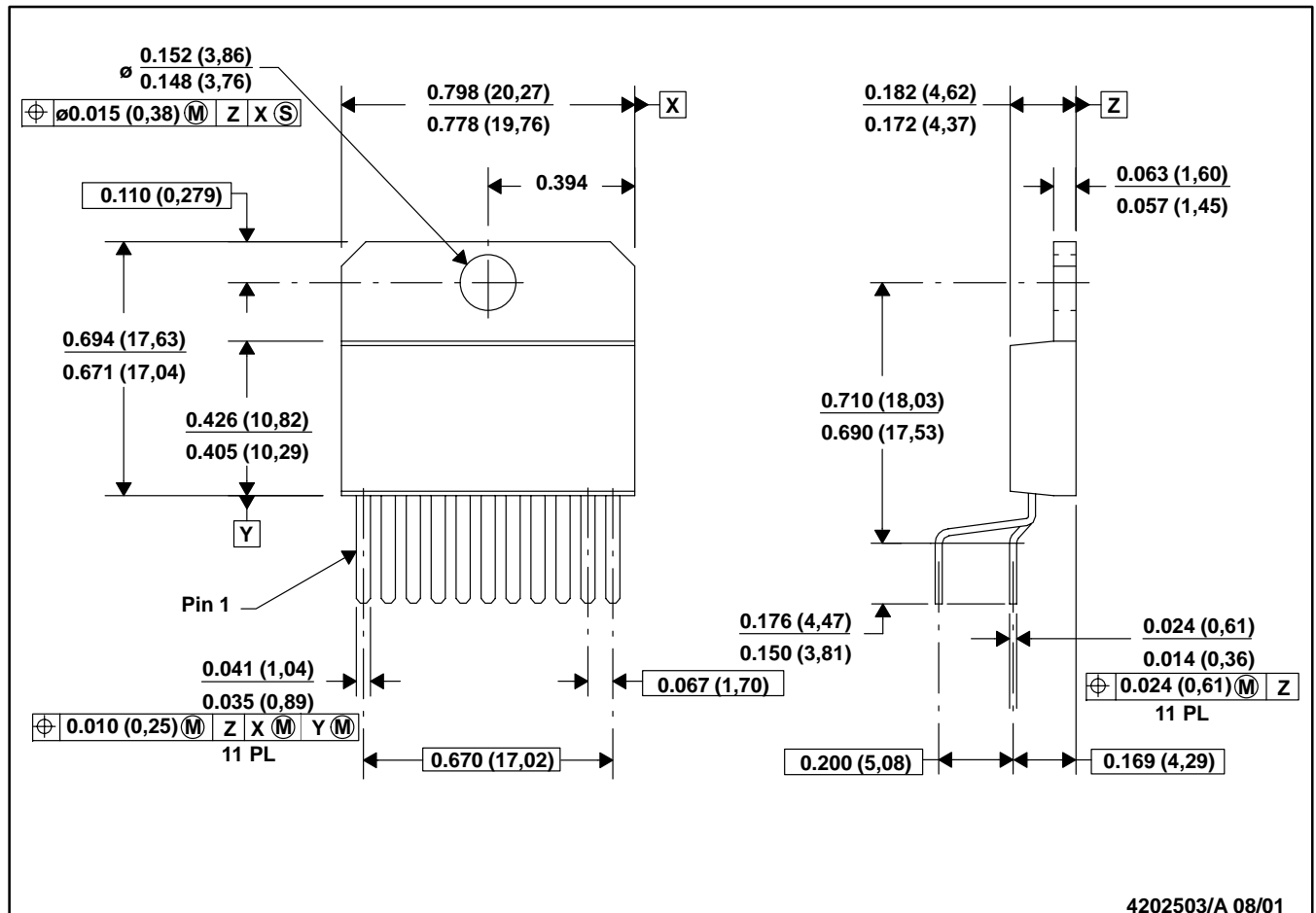

FIGURE 14. Parallel Output for Increased Output Current.

KV (R-PZFM-T11)

PLASTIC FLANGE-MOUNT



- NOTES: A. All linear dimensions are in inches (millimeters).  
 B. This drawing is subject to change without notice.  
 C. Controlling dimension: inch.  
 D. All lead dimensions apply before solder dip.  
 E. Falls within JEDEC MO-48-AA.

KVC (R-PSFM-T11)

PLASTIC FLANGE-MOUNT

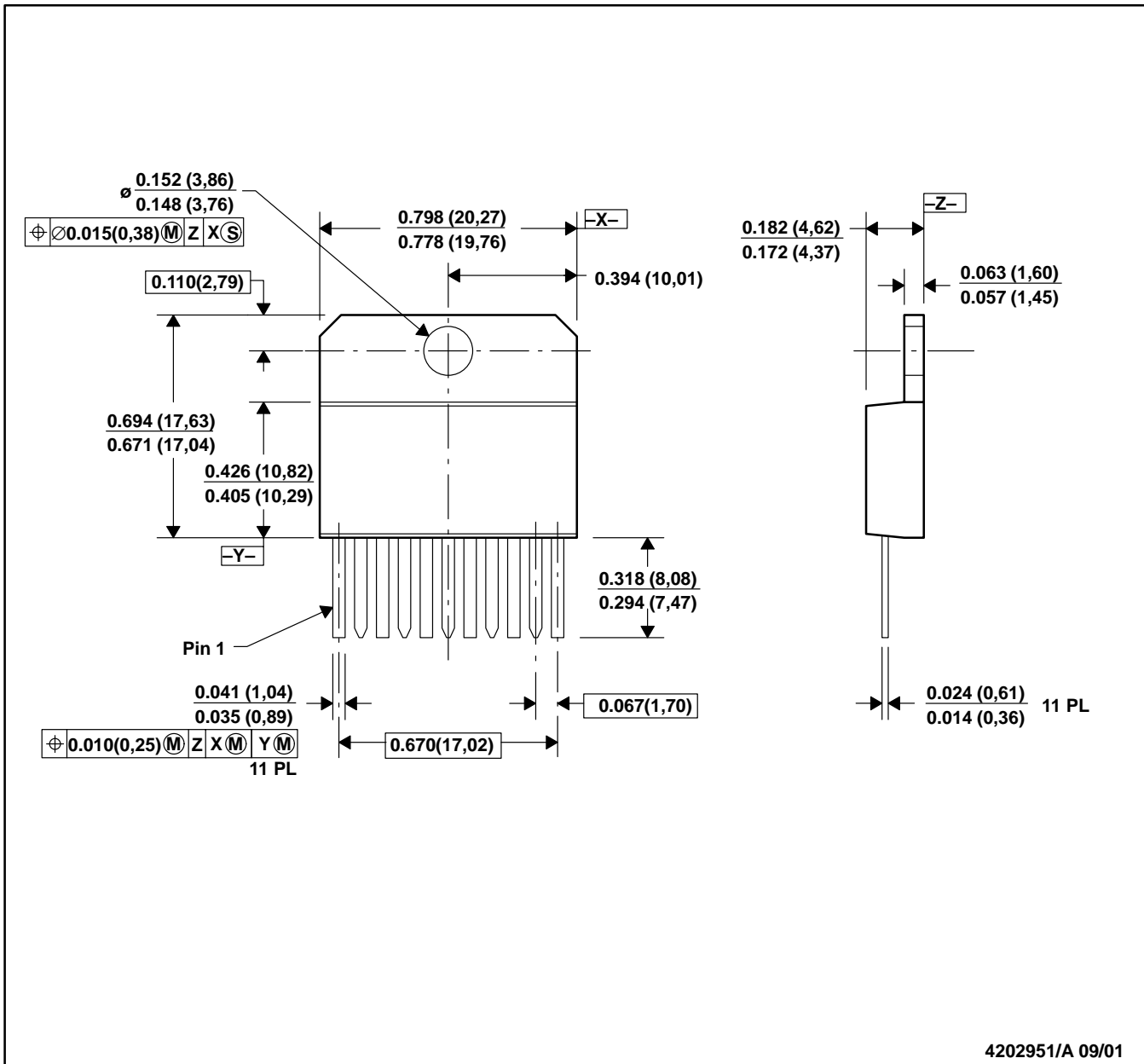

- A. All linear dimensions are in inches (millimeters).
- B. This drawing is subject to change without notice.
- C. Controlling dimension in inches.
- D. Falls within JEDEC MO-48-AA. Reference for body dimensions only (excluding lead forming dimensions).

## IMPORTANT NOTICE

Texas Instruments Incorporated and its subsidiaries (TI) reserve the right to make corrections, modifications, enhancements, improvements, and other changes to its products and services at any time and to discontinue any product or service without notice. Customers should obtain the latest relevant information before placing orders and should verify that such information is current and complete. All products are sold subject to TI's terms and conditions of sale supplied at the time of order acknowledgment.

TI warrants performance of its hardware products to the specifications applicable at the time of sale in accordance with TI's standard warranty. Testing and other quality control techniques are used to the extent TI deems necessary to support this warranty. Except where mandated by government requirements, testing of all parameters of each product is not necessarily performed.

TI assumes no liability for applications assistance or customer product design. Customers are responsible for their products and applications using TI components. To minimize the risks associated with customer products and applications, customers should provide adequate design and operating safeguards.

TI does not warrant or represent that any license, either express or implied, is granted under any TI patent right, copyright, mask work right, or other TI intellectual property right relating to any combination, machine, or process in which TI products or services are used. Information published by TI regarding third-party products or services does not constitute a license from TI to use such products or services or a warranty or endorsement thereof. Use of such information may require a license from a third party under the patents or other intellectual property of the third party, or a license from TI under the patents or other intellectual property of TI.

Reproduction of information in TI data books or data sheets is permissible only if reproduction is without alteration and is accompanied by all associated warranties, conditions, limitations, and notices. Reproduction of this information with alteration is an unfair and deceptive business practice. TI is not responsible or liable for such altered documentation.

Resale of TI products or services with statements different from or beyond the parameters stated by TI for that product or service voids all express and any implied warranties for the associated TI product or service and is an unfair and deceptive business practice. TI is not responsible or liable for any such statements.

### Mailing Address:

Texas Instruments  
Post Office Box 655303  
Dallas, Texas 75265