

OPA633

High Speed BUFFER AMPLIFIER

FEATURES

- WIDE BANDWIDTH: 260MHz
- HIGH SLEW RATE: 2500V/ μ s
- HIGH OUTPUT CURRENT: 100mA
- LOW OFFSET VOLTAGE: 1.5mV
- REPLACES HA-5033
- IMPROVED PERFORMANCE/PRICE:
LH0033, LTC1010, H0S200

APPLICATIONS

- OP AMP CURRENT BOOSTER
- VIDEO BUFFER
- LINE DRIVER
- A/D CONVERTER INPUT BUFFER

DESCRIPTION

The OPA633 is a monolithic unity-gain buffer amplifier featuring very wide bandwidth and high slew rate. A dielectric isolation process incorporating both NPN and PNP high frequency transistors achieves performance unattainable with conventional integrated circuit technology. Laser trimming provides low input offset voltage.

High output current capability allows the OPA633 to drive 50 Ω and 75 Ω lines, making it ideal for RF, IF and video applications. Low phase shift allows the OPA633 to be used inside amplifier feedback loops. OPA633 is available in a low cost plastic DIP package specified for 0°C to +75°C operation.

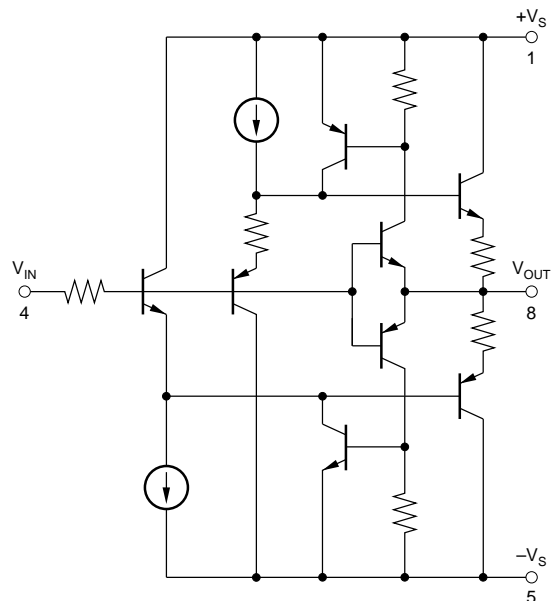

International Airport Industrial Park • Mailing Address: PO Box 11400 • Tucson, AZ 85734 • Street Address: 6730 S. Tucson Blvd. • Tucson, AZ 85706
Tel: (520) 746-1111 • Twx: 910-952-1111 • Cable: BBRCORP • Telex: 066-6491 • FAX: (520) 889-1510 • Immediate Product Info: (800) 548-6132

SPECIFICATIONS

ELECTRICAL

At +25°C, $V_S = \pm 12V$, $R_S = 50\Omega$, $R_L = 100\Omega$, and $C_L = 10pF$, unless otherwise specified.

PARAMETER	CONDITIONS	OPA633KP			UNITS
		MIN	TYP	MAX	
FREQUENCY RESPONSE					
Small Signal Bandwidth	$V_O = 1V_{rms}$, $R_L = 1k\Omega$ $V_O = 10V$, $V_S = \pm 15V$, $R_L = 1k\Omega$ $V_O = 500mV$		260		MHz
Full Power Bandwidth			40		MHz
Slew Rate		1000	2500		V/ μs
Rise Time, 10% to 90%			2.5		ns
Propagation Delay			1		ns
Overshoot			10		%
Settling Time, 0.1%			50		ns
Differential Phase Error ⁽¹⁾			0.1		Degrees
Differential Gain Error ⁽¹⁾			0.1		%
Total Harmonic Distortion	$V_O = 1V_{rms}$, $R_L = 1k\Omega$, $f = 100kHz$ $V_O = 1V_{rms}$, $R_L = 100\Omega$, $f = 100kHz$		0.005		%
			0.02		%
OUTPUT CHARACTERISTICS					
Voltage	$T_A = T_{MIN}$ to T_{MAX} $R_L = 1k\Omega$, $V_S = \pm 15V$	± 8	± 10		V
Current		± 11	± 13		V
Resistance		± 80	± 100		mA
			5		Ω
TRANSFER CHARACTERISTICS					
Gain	$R_L = 1k\Omega$ $T_A = T_{MIN}$ to T_{MAX}	0.93	0.95		V/V
		0.92	0.99		V/V
			0.95		V/V
INPUT					
Offset Voltage	$T_A = +25^\circ C$ $T_A = T_{MIN}$ to T_{MAX}		± 5	± 15	mV
vs Temperature			± 6	± 25	mV
vs Supply			± 33		$\mu V/^\circ C$
Bias Current	$T_A = T_{MIN}$ to T_{MAX} $T_A = +25^\circ C$	54	72		dB
Noise Voltage	$T_A = T_{MIN}$ to T_{MAX}		± 15	± 35	μA
Resistance	$T_A = T_{MIN}$ to T_{MAX} 10Hz to 1MHz		± 20	± 50	μA
Capacitance			20		$\mu Vp-p$
			1.5		M Ω
			1.6		pF
POWER SUPPLY					
Rated Supply Voltage	Specified Performance		± 12		V
Operating Supply Voltage	Derated Performance	± 5		± 16	V
Current, Quiescent	$I_O = 0$		21	25	mA
	$I_O = 0$, $T_A = T_{MIN}$ to T_{MAX}		21	30	mA
TEMPERATURE RANGE					
Specification, Ambient		0		+75	$^\circ C$
Operating, Ambient		-25		+85	$^\circ C$
θ Junction, Ambient			90		$^\circ C/W$

NOTE: (1) Differential phase error in video transmission systems is the change in phase of a color subcarrier resulting from a change in picture signal from blanked to white. Differential gain error is the change in amplitude at the color subcarrier frequency resulting from a change in picture signal from blanked to white.

PIN CONFIGURATION

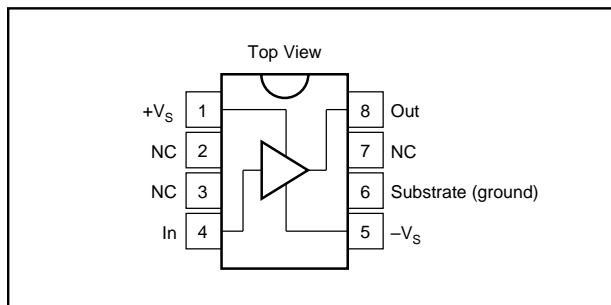

ABSOLUTE MAXIMUM RATINGS

Power Supply, $\pm V_S$	$\pm 20V$
Input Voltage V_{IN}	$+V_S + 2V$ to $-V_S - 2V$
Output Current (peak)	$\pm 200mA$
Internal Power Dissipation (25°C)	1.95W
Junction Temperature	200°C
Storage Temperature Range	-40°C to +85°C
Lead Temperature (soldering, 10s)	300°C

PACKAGE INFORMATION⁽¹⁾

MODEL	PACKAGE	PACKAGE DRAWING NUMBER
OPA633KP	8-Pin Plastic DIP	006

NOTE: (1) For detailed drawing and dimension table, please see end of data sheet, or Appendix D of Burr-Brown IC Data Book.

ORDERING INFORMATION

MODEL	PACKAGE	TEMPERATURE RANGE
OPA633KP	8-Pin Plastic DIP	0°C to +75°C



OPA633

TYPICAL PERFORMANCE CURVES

At +25°C, $V_S = \pm 12V$, $R_S = 50\Omega$, $R_L = 100\Omega$, and $C_L = 10pF$, unless otherwise specified.

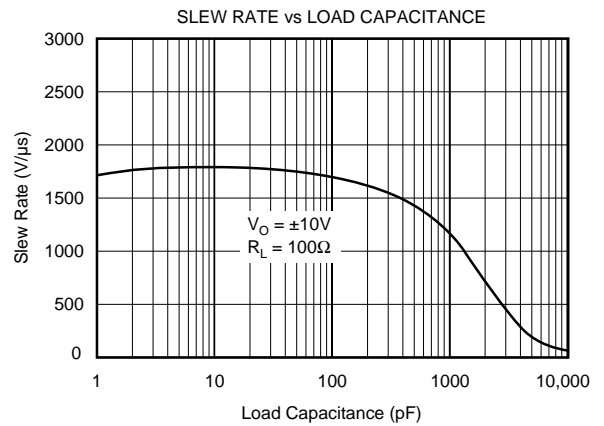
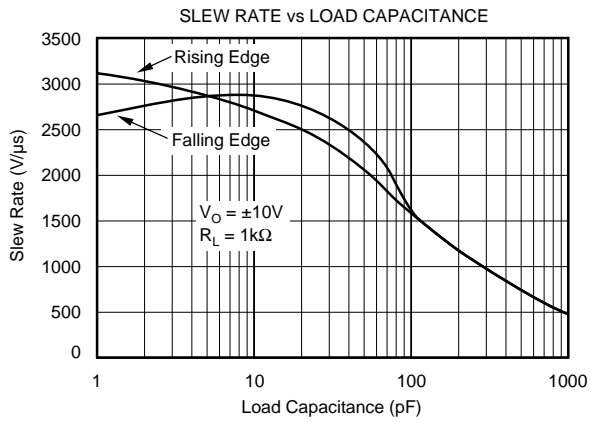
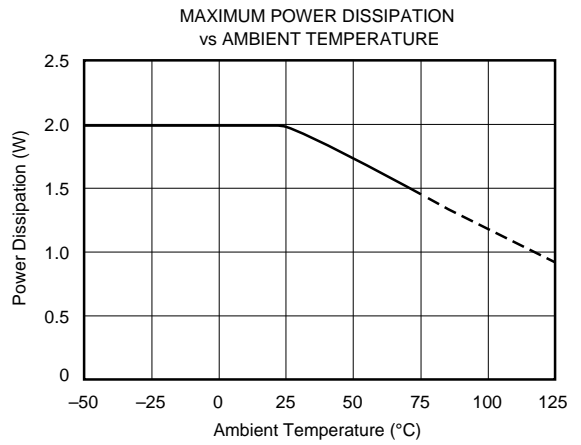
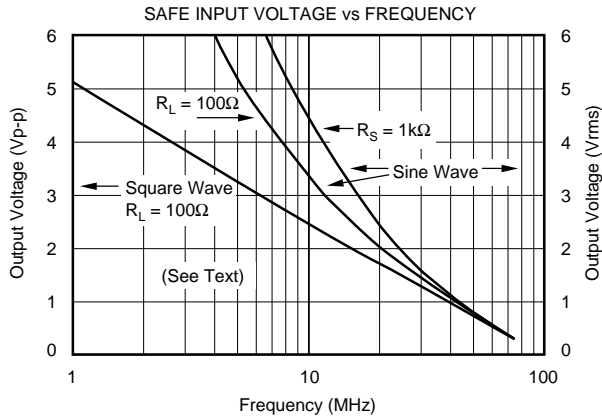
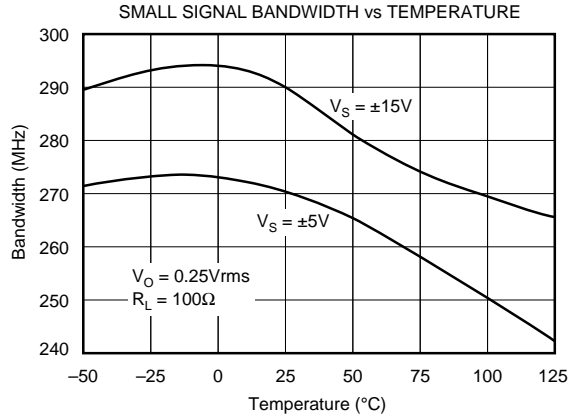
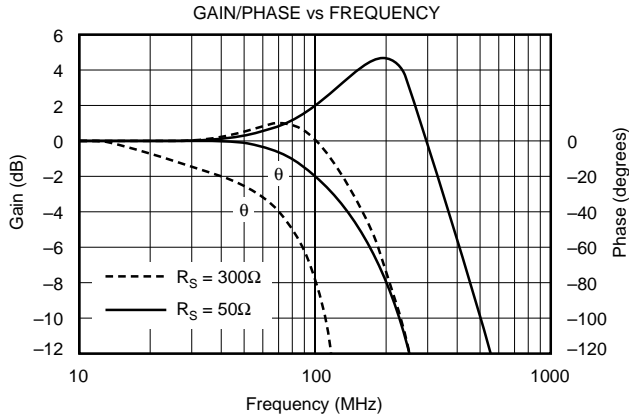

TYPICAL PERFORMANCE CURVES (CONT)

At +25°C, $V_S = \pm 12V$, $R_S = 50\Omega$, $R_L = 100\Omega$, and $C_L = 10pF$, unless otherwise specified.

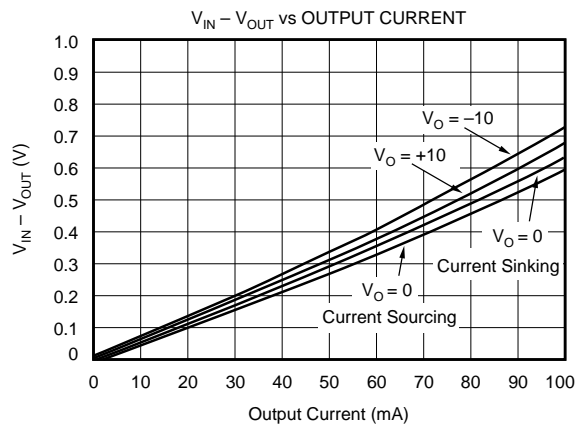
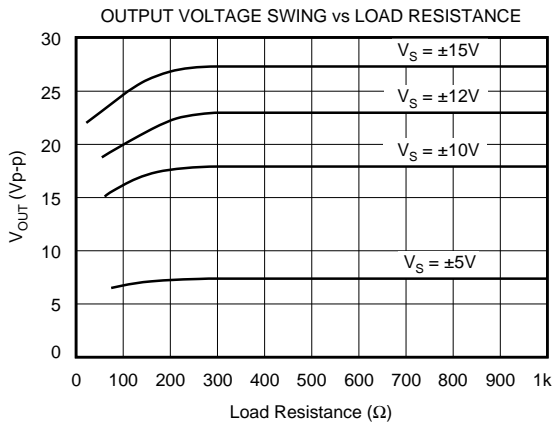
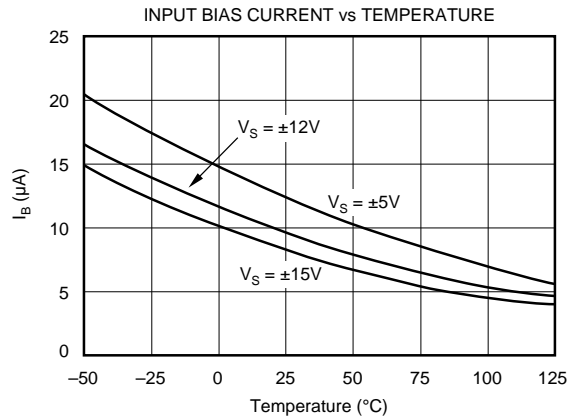
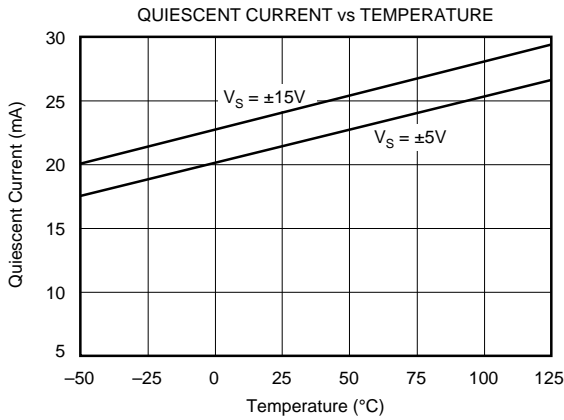
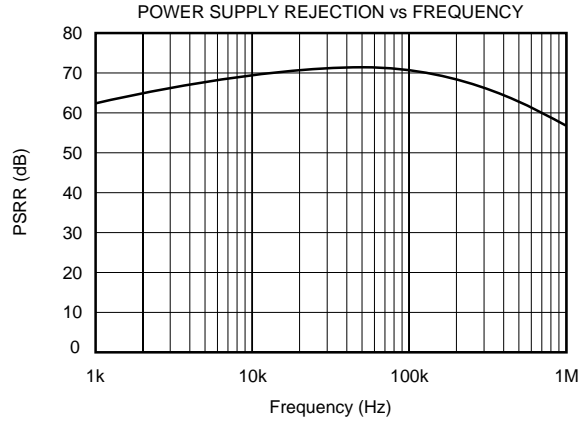
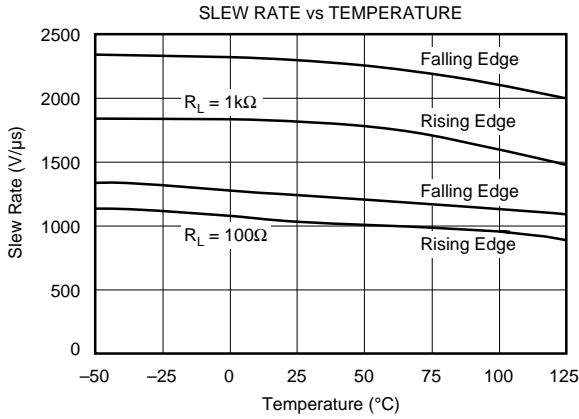

TYPICAL PERFORMANCE CURVES (CONT)

At +25°C, $V_S = \pm 12V$, $R_S = 50\Omega$, $R_L = 100\Omega$, and $C_L = 10pF$, unless otherwise specified.

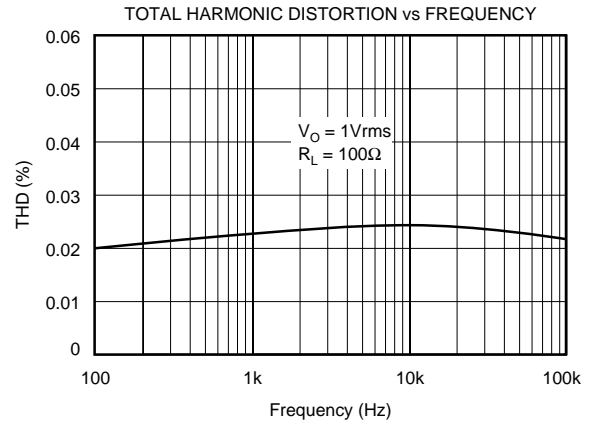
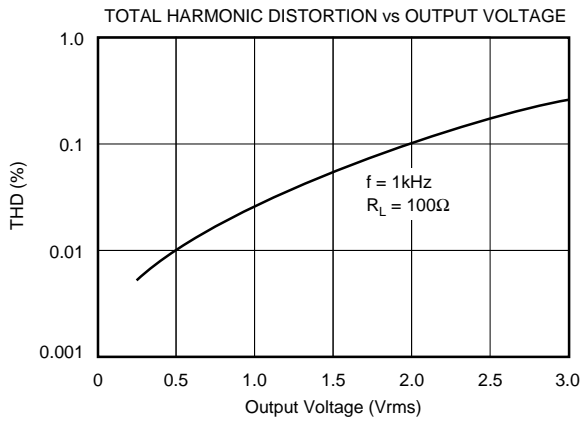
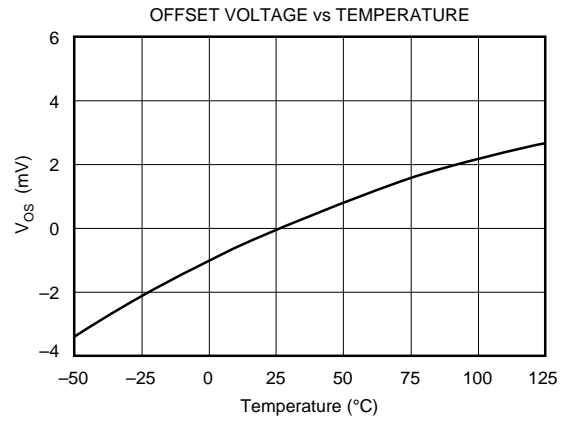
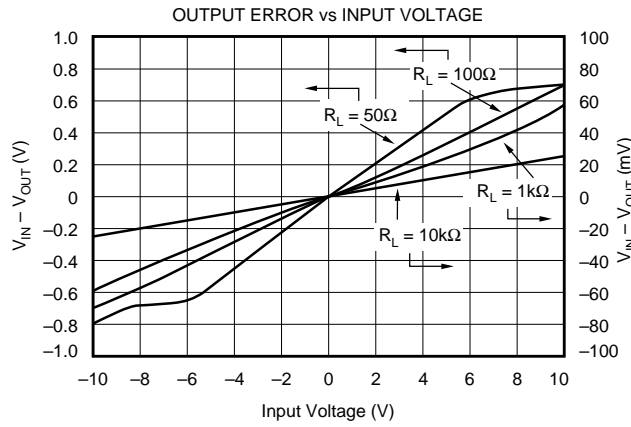
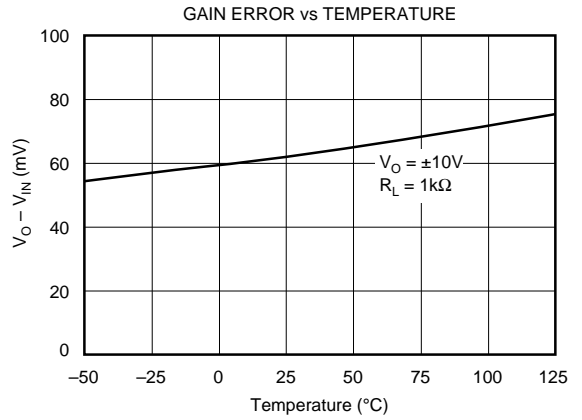
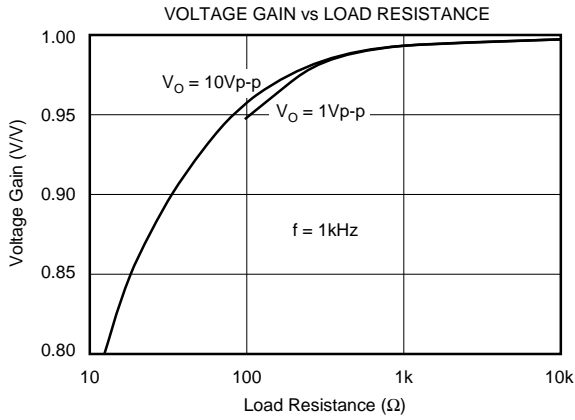

APPLICATIONS INFORMATION

As with any high frequency circuitry, good circuit layout technique must be used to achieve optimum performance. Power supply connections must be bypassed with high frequency capacitors. Many applications benefit from the use of two capacitors on each power supply—a ceramic capacitor for good high frequency decoupling and a tantalum type for lower frequencies. They should be located as close as possible to the buffer's power supply pins. A large ground plane is used to minimize high frequency ground drops and stray coupling.

Pin 6 connects to the substrate of the integrated circuit and should be connected to ground. In principle it could also be connected to $+V_S$ or $-V_S$, but ground is preferable. The additional lead length and capacitance associated with sockets may cause problems in applications requiring the highest fidelity of high speed pulses.

Depending on the nature of the input source impedance, a series input resistor may be required for best stability. This behavior is influenced somewhat by the load impedance (including any reactive effects). A value of 50Ω to 200Ω is typical. This resistor should be located close to the OPA633's input pin to avoid stray capacitance at the input which could reduce bandwidth (see Gain and Phase versus Frequency curve).

OVERLOAD CONDITIONS

The input and output circuitry of the OPA633 are not protected from overload. When the input signal and load characteristics are within the devices's capabilities, no protection circuitry is required. Exceeding device limits can result in permanent damage.

The OPA633's small package and high output current capability can lead to overheating. The internal junction temperature should not be allowed to exceed 150°C . Although failure is unlikely to occur until junction temperature exceeds 200°C , reliability of the part will be degraded significantly at such high temperatures. Since significant heat transfer takes place through the package leads, wide printed circuit traces to all leads will improve heat sinking. Sockets reduce heat transfer significantly and are not recommended.

Junction temperature rise is proportional to internal power dissipation. This can be reduced by using the minimum supply voltage necessary to produce the required output voltage swing. For instance, 1V video signals can be easily handled with $\pm 5\text{V}$ power supplies thus minimizing the internal power dissipation.

Output overloads or short circuits can result in permanent damage by causing excessive output current. The 50Ω or 75Ω series output resistor used to match line impedance will, in most cases, provide adequate protection. When this resistor is not used, the device can be protected by limiting the power supply current. See "Protection Circuits."

Excessive input levels at high frequency can cause increased internal dissipation and permanent damage. See the safe

input voltage versus frequency curves. When used to buffer an op amp's output, the input to the OPA633 is limited, in most cases, by the op amp. When high frequency inputs can exceed safe levels, the device must be protected by limiting the power supply current.

PROTECTION CIRCUITS

The OPA633 can be protected from damage due to excessive currents by the simple addition of resistors in series with the power supply pins (Figure 5a). While this limits output current, it also limits voltage swing with low impedance loads. This reduction in voltage swing is minimal for AC or high crest factor signals since only the average current from the power supply causes a voltage drop across the series resistor. Short duration load-current peaks are supplied by the bypass capacitors.

The circuit of Figure 5b overcomes the limitations of the previous circuit with DC loads. It allows nearly full output voltage swing up to its current limit of approximately 140mA. Both circuits require good high frequency capacitors (e.g., tantalum) to bypass the buffer's power supply connections.

CAPACITIVE LOADS

The OPA633 is designed to safely drive capacitive loads up to $0.01\mu\text{F}$. It must be understood, however, that rapidly changing voltages demand large output load currents:

$$I_{\text{LOAD}} = C_{\text{LOAD}} \frac{dV}{dt}$$

Thus, a signal slew rate of $1000\text{V}/\mu\text{s}$ and load capacitance of $0.01\mu\text{F}$ demands a load current of 10A. Clearly maximum slew rates cannot be combined with large capacitive loads. Load current should be kept less than 100mA continuous (200mA peak) by limiting the rate of change of the input signal or reducing the load capacitance.

USE INSIDE A FEEDBACK LOOP

The OPA633 may be used inside the feedback path of an op amp such as the OPA602. Higher output current is achieved without degradation in accuracy. This approach may actually improve performance in precision applications by removing load-dependent dissipation from a precision op amp. All vestiges of load-dependent offset voltage and temperature drift can be eliminated with this technique. Since the buffer is placed within the feedback loop of the op amp, its DC errors will have a negligible effect on overall accuracy. Any DC errors contributed by the buffer are divided by the loop gain of the op amp.

The low phase shift of the OPA633 allows its use inside the feedback loop of a wide variety of op amps. To assure stability, the buffer must not add significant phase shift to the loop at the gain crossing frequency of the circuit—the frequency at which the open loop gain of the op amp is equal to the closed loop gain of the application. The OPA633 has a typical phase shift of less than 10° up to 70MHz, thus making it useful even with wideband op amps.

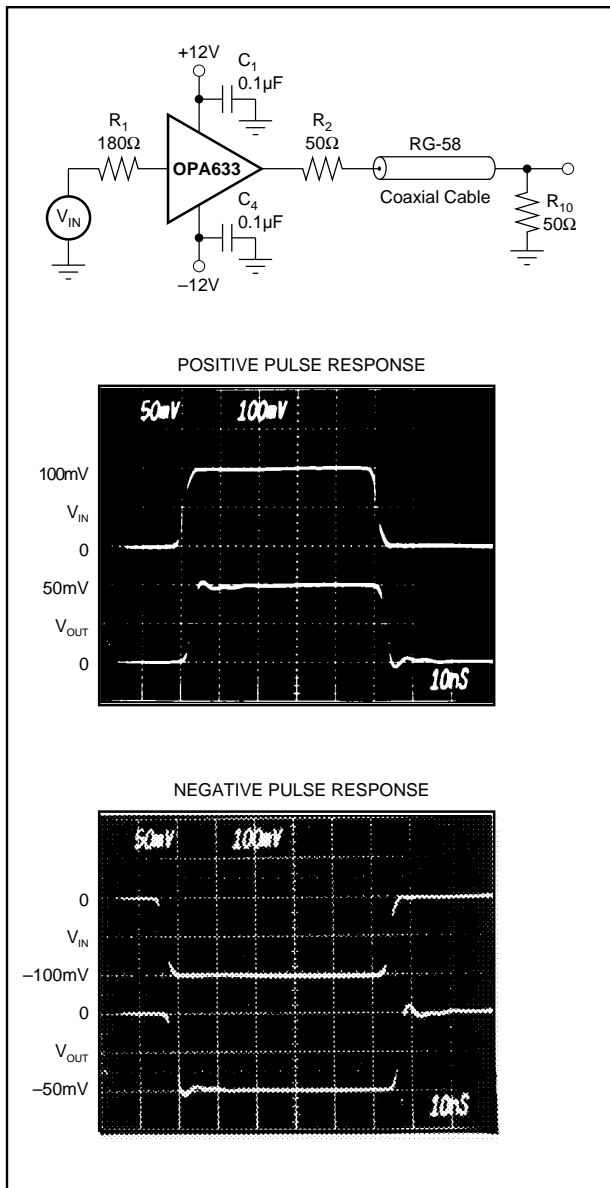

FIGURE 1. Coaxial Cable Driver Circuit.

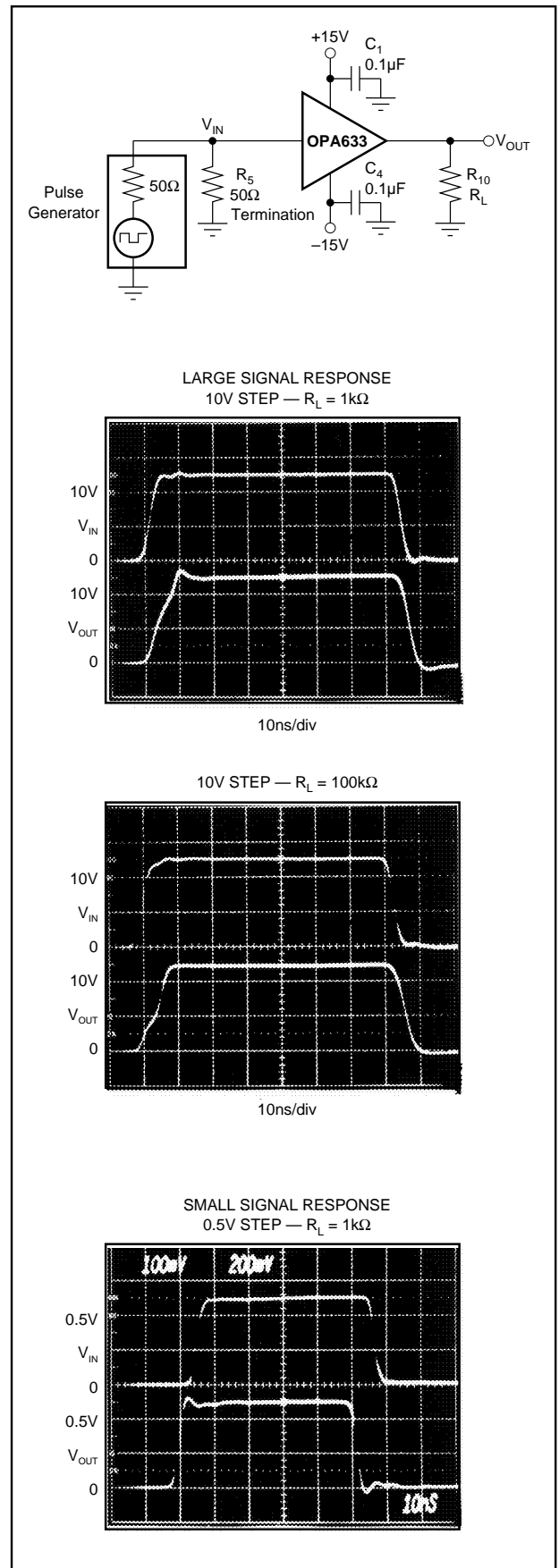

FIGURE 2. Dynamic Response Test Circuit.

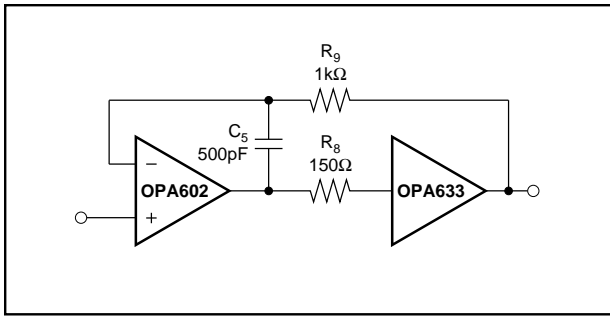

FIGURE 3. Precision High Current Buffer.

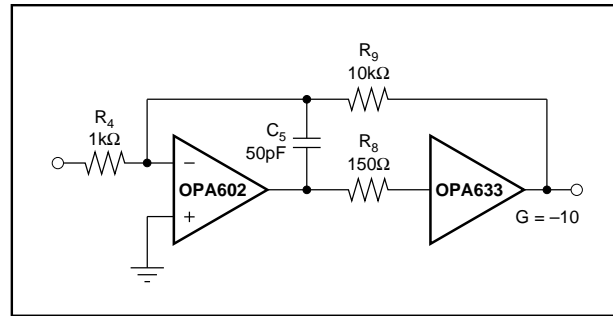

FIGURE 4. Buffered Inverting Amplifier.

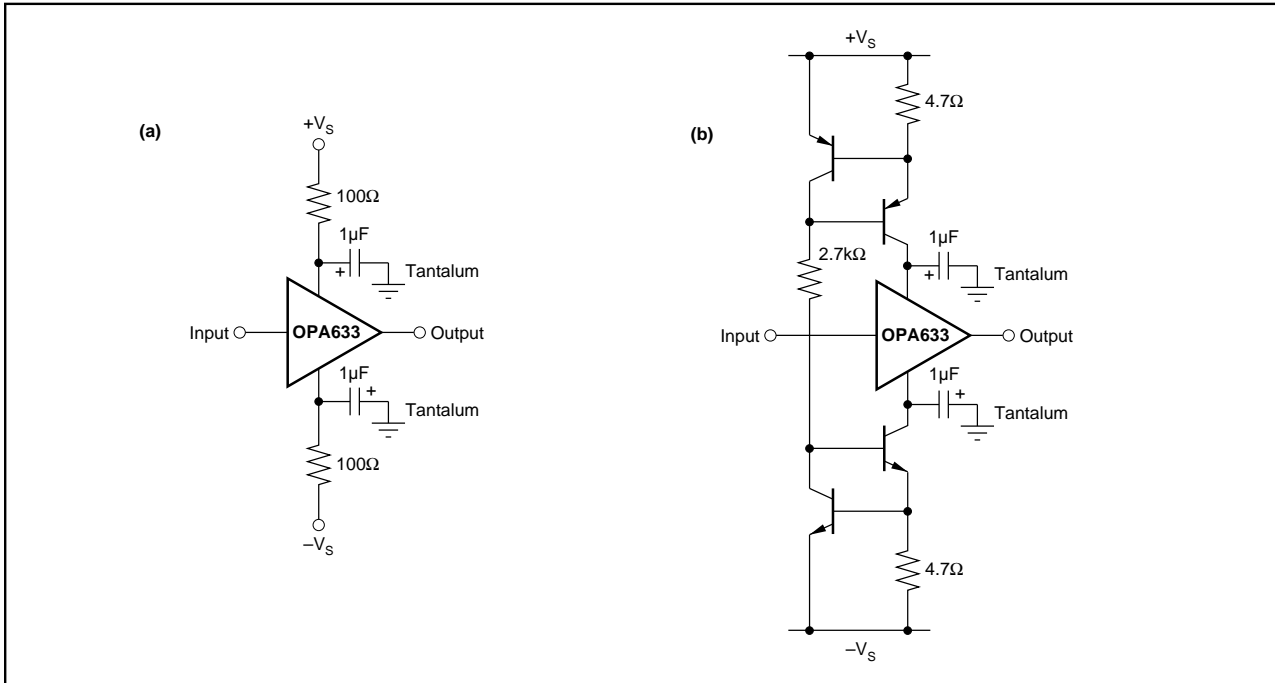

FIGURE 5. Output Protection Circuits.

The information provided herein is believed to be reliable; however, BURR-BROWN assumes no responsibility for inaccuracies or omissions. BURR-BROWN assumes no responsibility for the use of this information, and all use of such information shall be entirely at the user's own risk. Prices and specifications are subject to change without notice. No patent rights or licenses to any of the circuits described herein are implied or granted to any third party. BURR-BROWN does not authorize or warrant any BURR-BROWN product for use in life support devices and/or systems.

PACKAGING INFORMATION

Orderable Device	Status ⁽¹⁾	Package Type	Package Drawing	Pins	Package Qty	Eco Plan ⁽²⁾	Lead/Ball Finish	MSL Peak Temp ⁽³⁾
OPA633KP	ACTIVE	PDIP	P	8	50	Pb-Free (RoHS)	Call TI	Level-NC-NC-NC

⁽¹⁾ The marketing status values are defined as follows:

ACTIVE: Product device recommended for new designs.

LIFEBUY: TI has announced that the device will be discontinued, and a lifetime-buy period is in effect.

NRND: Not recommended for new designs. Device is in production to support existing customers, but TI does not recommend using this part in a new design.

PREVIEW: Device has been announced but is not in production. Samples may or may not be available.

OBSOLETE: TI has discontinued the production of the device.

⁽²⁾ Eco Plan - May not be currently available - please check <http://www.ti.com/productcontent> for the latest availability information and additional product content details.

None: Not yet available Lead (Pb-Free).

Pb-Free (RoHS): TI's terms "Lead-Free" or "Pb-Free" mean semiconductor products that are compatible with the current RoHS requirements for all 6 substances, including the requirement that lead not exceed 0.1% by weight in homogeneous materials. Where designed to be soldered at high temperatures, TI Pb-Free products are suitable for use in specified lead-free processes.

Green (RoHS & no Sb/Br): TI defines "Green" to mean "Pb-Free" and in addition, uses package materials that do not contain halogens, including bromine (Br) or antimony (Sb) above 0.1% of total product weight.

⁽³⁾ MSL, Peak Temp. -- The Moisture Sensitivity Level rating according to the JEDEC industry standard classifications, and peak solder temperature.

Important Information and Disclaimer: The information provided on this page represents TI's knowledge and belief as of the date that it is provided. TI bases its knowledge and belief on information provided by third parties, and makes no representation or warranty as to the accuracy of such information. Efforts are underway to better integrate information from third parties. TI has taken and continues to take reasonable steps to provide representative and accurate information but may not have conducted destructive testing or chemical analysis on incoming materials and chemicals. TI and TI suppliers consider certain information to be proprietary, and thus CAS numbers and other limited information may not be available for release.

In no event shall TI's liability arising out of such information exceed the total purchase price of the TI part(s) at issue in this document sold by TI to Customer on an annual basis.

IMPORTANT NOTICE

Texas Instruments Incorporated and its subsidiaries (TI) reserve the right to make corrections, modifications, enhancements, improvements, and other changes to its products and services at any time and to discontinue any product or service without notice. Customers should obtain the latest relevant information before placing orders and should verify that such information is current and complete. All products are sold subject to TI's terms and conditions of sale supplied at the time of order acknowledgment.

TI warrants performance of its hardware products to the specifications applicable at the time of sale in accordance with TI's standard warranty. Testing and other quality control techniques are used to the extent TI deems necessary to support this warranty. Except where mandated by government requirements, testing of all parameters of each product is not necessarily performed.

TI assumes no liability for applications assistance or customer product design. Customers are responsible for their products and applications using TI components. To minimize the risks associated with customer products and applications, customers should provide adequate design and operating safeguards.

TI does not warrant or represent that any license, either express or implied, is granted under any TI patent right, copyright, mask work right, or other TI intellectual property right relating to any combination, machine, or process in which TI products or services are used. Information published by TI regarding third-party products or services does not constitute a license from TI to use such products or services or a warranty or endorsement thereof. Use of such information may require a license from a third party under the patents or other intellectual property of the third party, or a license from TI under the patents or other intellectual property of TI.

Reproduction of information in TI data books or data sheets is permissible only if reproduction is without alteration and is accompanied by all associated warranties, conditions, limitations, and notices. Reproduction of this information with alteration is an unfair and deceptive business practice. TI is not responsible or liable for such altered documentation.

Resale of TI products or services with statements different from or beyond the parameters stated by TI for that product or service voids all express and any implied warranties for the associated TI product or service and is an unfair and deceptive business practice. TI is not responsible or liable for any such statements.

Following are URLs where you can obtain information on other Texas Instruments products and application solutions:

Products		Applications	
Amplifiers	amplifier.ti.com	Audio	www.ti.com/audio
Data Converters	dataconverter.ti.com	Automotive	www.ti.com/automotive
DSP	dsp.ti.com	Broadband	www.ti.com/broadband
Interface	interface.ti.com	Digital Control	www.ti.com/digitalcontrol
Logic	logic.ti.com	Military	www.ti.com/military
Power Mgmt	power.ti.com	Optical Networking	www.ti.com/opticalnetwork
Microcontrollers	microcontroller.ti.com	Security	www.ti.com/security
		Telephony	www.ti.com/telephony
		Video & Imaging	www.ti.com/video
		Wireless	www.ti.com/wireless

Mailing Address: Texas Instruments
Post Office Box 655303 Dallas, Texas 75265