

PT7709—5V



20 Amp Programmable
Next Generation “Big Hammer”

SLTS084

(Revised 6/30/2000)

Description

The PT7709 is a next generation “Big Hammer”, high-performance Integrated Switching Regulator (ISR), which is made available in Power Trends’ aluminum 27-pin SIP package. The PT7709 improves on the popular PT7705 with 20A of output current and short circuit protection.

The PT7709 is suitable for existing 5V system designs that require power for the latest high-speed, low-

voltage μ Ps, and bus drivers.

The PT7709 output is programmable from 1.3V to 3.5V with a 5-bit input, which is compatible with the Intel Pentium® Processor. A differential remote sense is also provided to compensate for voltage drop between the ISR and load.

Only 330 μ F of output capacitance are required for proper operation.

Standard Application

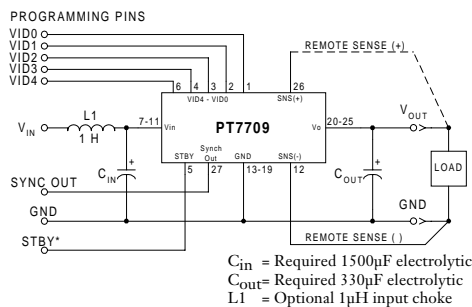

Pin-Out Information

Pin	Function	Pin	Function	Pin	Function
1	VID0	10	V_{in}	19	GND
2	VID1	11	V_{in}	20	V_{out}
3	VID2	12	Remote Sense Gnd (4)	21	V_{out}
4	VID3	13	GND	22	V_{out}
5	STBY* - Stand-by	14	GND	23	V_{out}
6	VID4	15	GND	24	V_{out}
7	V_{in}	16	GND	25	V_{out}
8	V_{in}	17	GND	26	Remote Sense V_{out}
9	V_{in}	18	GND	27	Sync Out

For STBY* pin:
 open = output enabled
 ground = output disabled.

Specifications

Characteristics ($T_a = 25^\circ\text{C}$ unless noted)	Symbols	Conditions	PT7709 SERIES			Units	
			Min	Typ	Max		
Output Current	I_o	$T_a = +60^\circ\text{C}$, 200 LFM, pkg N $T_a = +25^\circ\text{C}$, natural convection	0.1 (1) 0.1 (1)	—	20 20	A	
Input Voltage Range	V_{in}	$0.1\text{A} \leq I_o \leq 20\text{A}$	4.5	—	5.5	V	
Output Voltage Tolerance	ΔV_o	$V_{in} = +5\text{V}$, $I_o = 20\text{A}$ $0^\circ\text{C} \leq T_a \leq +65^\circ\text{C}$	$V_o - 0.03$	—	$V_o + 0.03$	V	
Line Regulation	Reg_{line}	$4.5\text{V} \leq V_{in} \leq 5.5\text{V}$, $I_o = 20\text{A}$	—	± 10	—	mV	
Load Regulation	Reg_{load}	$V_{in} = +5\text{V}$, $0.1 \leq I_o \leq 20\text{A}$	—	± 10	—	mV	
V_o Ripple/Noise	V_n	$V_{in} = +5\text{V}$, $I_o = 20\text{A}$	—	50	—	mV	
Transient Response with $C_{out} = 330\mu\text{F}$	t_{tr} V_{os}	I_o step between 10A and 20A V_o over/undershoot	—	50 100	—	μSec mV	
Efficiency	η	$V_{in} = +5\text{V}$, $I_o = 10\text{A}$	$V_o = 3.3\text{V}$	—	92	—	%
			$V_o = 2.5\text{V}$	—	90	—	%
			$V_o = 1.8\text{V}$	—	87	—	%
		$V_{in} = +5\text{V}$, $I_o = 20\text{A}$	$V_o = 3.3\text{V}$	—	90	—	%
		$V_o = 2.5\text{V}$	—	87	—	%	
		$V_o = 1.8\text{V}$	—	82	—	%	
Switching Frequency	f_o	$4.5\text{V} \leq V_{in} \leq 5.5\text{V}$ $0.1\text{A} \leq I_o \leq 20\text{A}$	300	350	400	kHz	
Absolute Maximum Operating Temperature Range	T_a	Over V_{in} and I_o Ranges	-40 (2)	—	+85 (3)	$^\circ\text{C}$	
Storage Temperature	T_s	—	-40	—	+125	$^\circ\text{C}$	
Mechanical Shock	—	Per Mil-STD-883D, Method 2002.3 1 msec, Half Sine, mounted to a fixture	—	500	—	G's	
Mechanical Vibration	—	Per Mil-STD-883D, Method 2007.2, 20-2000 Hz, Soldered in a PC board	—	10	—	G's	
Weight	—	Vertical/Horizontal	—	31/41	—	grams	

- Notes:** (1) ISR—will operate down to no load with reduced specifications.
 (2) For operation below 0°C , C_{in} and C_{out} must have stable characteristics. Use either low ESR tantalum or Oscon® capacitors.
 (3) See Safe Operating Area curves or contact the factory for the appropriate derating.
 (4) If the Remote Sense Ground is not used, pin 12 must be connected to pin 13 for optimum output voltage accuracy.

External Capacitors: The PT7709 requires a minimum output capacitance of 330 μ F for proper operation. The PT7709 also requires an input capacitance of 1500 μ F, which must be rated for a minimum of 1.4Arms of ripple current. For transient or dynamic load applications, additional capacitance may be required. For more information refer to the application note regarding capacitor selection for this product.

Input Filter: An input filter inductor is optional for most applications. The inductor must be sized to handle 20ADC with a typical value of 1 μ H.

PT7709—5V

20 Amp Programmable Next Generation “Big Hammer”

Features

- Single-Device: +5V input
- 5-bit Programmable:
1.3V to 3.5V@20A
- High Efficiency
- Differential Remote Sense
- Short-Circuit Protection
- Parallelable with PT7743
20A “Current Booster”

Programming Information

VID3	VID2	VID1	VID0	VID4=1 Vout	VID4=0 Vout
1	1	1	1	2.0V	1.30V
1	1	1	0	2.1V	1.35V
1	1	0	1	2.2V	1.40V
1	1	0	0	2.3V	1.45V
1	0	1	1	2.4V	1.50V
1	0	1	0	2.5V	1.55V
1	0	0	1	2.6V	1.60V
1	0	0	0	2.7V	1.65V
0	1	1	1	2.8V	1.70V
0	1	1	0	2.9V	1.75V
0	1	0	1	3.0V	1.80V
0	1	0	0	3.1V	1.85V
0	0	1	1	3.2V	1.90V
0	0	1	0	3.3V	1.95V
0	0	0	1	3.4V	2.00V
0	0	0	0	3.5V	2.05V

Logic 0 = Pin 12 potential (remote sense gnd)
Logic 1 = Open circuit (no pull-up resistors)
VID3 and VID4 may not be changed while the unit is operating.

Ordering Information

PT7709□ = 1.3 to 3.5 Volts

(For dimensions and PC board layout,
see Package Styles 800 and 810.)

PT Series Suffix (PT1234X)

Case/Pin Configuration

Vertical Through-Hole	N
Horizontal Through-Hole	A
Horizontal Surface Mount	C

TYPICAL CHARACTERISTICS

PT7709 Performance, $V_o = 3.3$ VDC (See Note A)

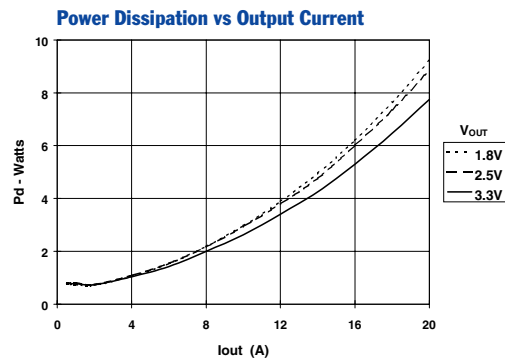
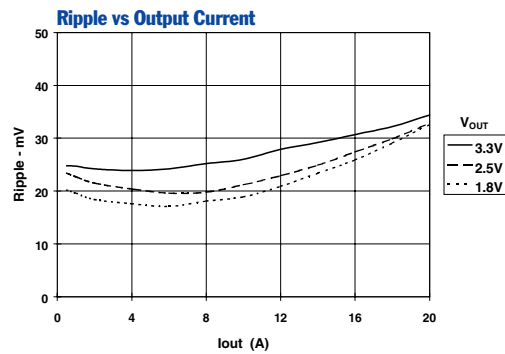
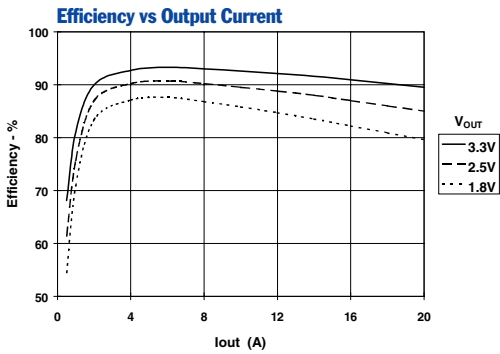

Safe Operating Area Curves (See Note B)

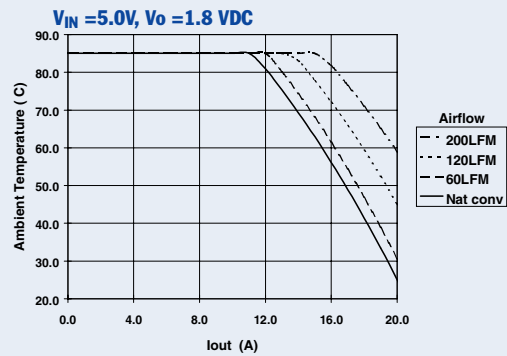
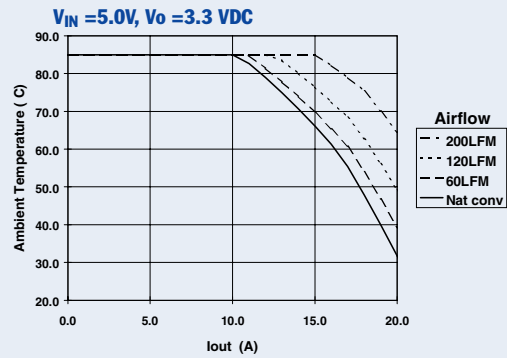

Note A: All data in the above graphs has been developed from actual products tested at 25°C. The data is considered typical for the ISR

Note B: SOA curves represent operating conditions at which internal components are at or below manufacturer's maximum rated operating temperatures.

PT7708/PT7709, PT7742/PT7743

Capacitor Recommendations for the PT7708/09 Regulators and PT7742/43 Current Boosters

Input Capacitors

The recommended input capacitance is determined by 1.4 ampere minimum ripple current rating and 1500µF minimum capacitance. Capacitors listed below must be rated for a minimum of 2x the input voltage with +5V operation. Ripple current and $\leq 100\text{m}\Omega$ Equivalent Series Resistance (ESR) values are the major considerations along with temperature when selecting the proper capacitor.

Output Capacitors

The minimum required output capacitance is 330µF with a maximum ESR less than or equal to 100mΩ. Failure to observe this requirement may lead to regulator instability or oscillation. Electrolytic capacitors have poor ripple performance at frequencies greater than 400kHz, but excellent low frequency transient response. Above the ripple frequency ceramic decoupling capacitors are necessary to improve the transient response and reduce any microprocessor high frequency noise components apparent during higher current excursions. Preferred low ESR type capacitor part numbers are identified in the Table 1 below.

Tantalum Characteristics

Tantalum capacitors with a minimum 10V rating are recommended on the output bus, but only the AVX TPS Series, Sprague 594/595 Series, or Kemet T495/T510 Series. The AVX TPS Series, Sprague Series or Kemet Series capacitors are specified over other types due to their higher surge current, excellent power dissipation and ripple current ratings. As an example, the TAJ Series by AVX is not recommended. This series exhibits considerably higher ESR, reduced power dissipation and lower ripple current capability. The TAJ Series is a less reliable compared to the TPS series when determining power dissipation capability.

Capacitor Table

Table 1 identifies the characteristics of capacitors from a number of vendors with acceptable ESR and ripple current (rms) ratings. The suggested minimum quantities per regulator for both the input and output buses are identified.

This is not an extensive capacitor list. The table below is a selection guide for input and output capacitors. Other capacitor vendors are available with comparable RMS ripple current rating and ESR (Equivalent Series Resistance at 100kHz). These critical parameters are necessary to insure both optimum regulator performance and long capacitor life.

Table 1 Capacitors Characteristic Data

Capacitor Vendor/ Series	Capacitor Characteristics					Quantity		Vendor Number
	Working Voltage	Value(µF)	(ESR) Equivalent Series Resistance	105°C Maximum Ripple Current(Irms)	Physical Size(mm)	Input Bus	Output Bus	
Panasonic FC Surface Mtg FA	16V	2200	0.038Ω	2000mA	18x16.5	1	1	EEVFC1C222N EEVFC1V331LQ
	35V	330	0.065Ω	1205mA	12.5x16.5			
	10V	680	0.090Ω	755mA	10x12.5		1	EEUFA1A681 EEUFA1C182A
	16V	1800	0.032Ω	2000mA	18x15	1	1	
United Chemi -Con LFXSeries	25V	330	0.084Ω	825mA	10x16		1	LXV25VB331M10X16LL LXV16VB222M16X20LL LXV16VB471M10X16LL
	16V	2200	0.038Ω	1630mA	16x20	1	1	
	16V	470	0.084Ω/2=042Ω	825mA x2	10x16		1	
Nichicon PL Series PM Series	10V	680	0.090Ω	770mA	10x15		1	UPL1A681MHH6 UPL1A182MHH6 UPL1E331MPH6
	10V	1800	0.044Ω	1420mA	16x15	1	1	
	25V	330	0.095Ω	750mA	10x15		1	
Oscon SS SV	10V	330	0.025W/4=0.006Ω	>9800mA	10x10.5	4	N/R	10SS330M 10SV330M(Sufvace Mtg)
	10V	330	0.020/4=0.005Ω	>9800mA	10.3x12.6	4	(Note)	
AVX Tanatalum TPS- Series	10V	330	0.100/5=20Ω	3500mA	7.3Lx	5	1	TPSV337M010R0100 TPSV337M010R0060
	10V	330	0.060Ω	1826mA	4.3Wx 4.1H	5	1	
Sprague Tantalum 595D/594D	10V	330	0.045W/4=0.011Ω	>4500mA	7.3L x 5.7W x	5	1	594D337X0010R2T Surface Mount 595D687X0010R2T
	10V	680	0.090Ω	>1660mA	4.0H	2	1	
Kemet Tantalum T510/T495 Series	10V	330	0.035Ω	2000mA	4.3Wx7.3L x4.0H	5	1	510X337M010AS Surface Mount
	10V	220	0.070Ω/2=0.035Ω	>2000mA		6	2	
Sanyo Poscap TPB	10V	220	0.040Ω	3000mA	7.2L x 4.3W x 3.1H	6	2	10TPB220M Surface Mount

Note: (N/R) is not recommended for this application, due to extremely low Equivalent Series Resistance (ESR)

IMPORTANT NOTICE

Texas Instruments and its subsidiaries (TI) reserve the right to make changes to their products or to discontinue any product or service without notice, and advise customers to obtain the latest version of relevant information to verify, before placing orders, that information being relied on is current and complete. All products are sold subject to the terms and conditions of sale supplied at the time of order acknowledgment, including those pertaining to warranty, patent infringement, and limitation of liability.

TI warrants performance of its semiconductor products to the specifications applicable at the time of sale in accordance with TI's standard warranty. Testing and other quality control techniques are utilized to the extent TI deems necessary to support this warranty. Specific testing of all parameters of each device is not necessarily performed, except those mandated by government requirements.

Customers are responsible for their applications using TI components.

In order to minimize risks associated with the customer's applications, adequate design and operating safeguards must be provided by the customer to minimize inherent or procedural hazards.

TI assumes no liability for applications assistance or customer product design. TI does not warrant or represent that any license, either express or implied, is granted under any patent right, copyright, mask work right, or other intellectual property right of TI covering or relating to any combination, machine, or process in which such semiconductor products or services might be or are used. TI's publication of information regarding any third party's products or services does not constitute TI's approval, warranty or endorsement thereof.