



100ppm/°C, 50µA in SOT23-3 CMOS VOLTAGE REFERENCE

FEATURES

- **MicroSIZE PACKAGE:** SOT23-3
- **LOW DROPOUT:** 1mV
- **HIGH OUTPUT CURRENT:** 25mA
- **LOW TEMPERATURE DRIFT:** 100ppm/°C max
- **HIGH ACCURACY:** 2%
- **LOW I_Q:** 50µA max

APPLICATIONS

- **PORTABLE, BATTERY-POWERED EQUIPMENT**
- **DATA ACQUISITION SYSTEMS**
- **MEDICAL EQUIPMENT**
- **HAND-HELD TEST EQUIPMENT**

DESCRIPTION

The REF29xx is a precision, low-power, low-voltage dropout voltage reference family available in a tiny SOT23-3.

The REF29xx's small size and low power consumption (50µA max) make it ideal for portable and battery-powered applications. The REF29xx does not require a load capacitor, but is stable with any capacitive load.

Unloaded, the REF29xx can be operated with supplies within 1mV of output voltage. All models are specified for the wide temperature range, -40°C to +125°C.

PRODUCT	VOLTAGE (V)
REF2912	1.25
REF2920	2.048
REF2925	2.5
REF2930	3.0
REF2933	3.3
REF2940	4.096

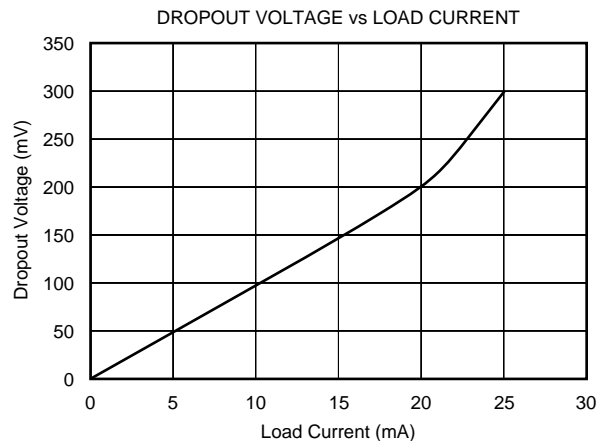
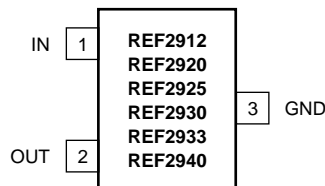

Please be aware that an important notice concerning availability, standard warranty, and use in critical applications of Texas Instruments semiconductor products and disclaimers thereto appears at the end of this data sheet.

ABSOLUTE MAXIMUM RATINGS⁽¹⁾

Supply Voltage, V+ to V-	5.5V
Output Short-Circuit ⁽²⁾	Continuous
Operating Temperature	-40°C to +125°C
Storage Temperature	-65°C to +125°C
Junction Temperature	+150°C
Lead Temperature (soldering, 10s)	+300°C

NOTES: (1) Stresses above these ratings may cause permanent damage. Exposure to absolute maximum conditions for extended periods may degrade device reliability. (2) Short-circuit to ground.



ELECTROSTATIC DISCHARGE SENSITIVITY

This integrated circuit can be damaged by ESD. Texas Instruments recommends that all integrated circuits be handled with appropriate precautions. Failure to observe proper handling and installation procedures can cause damage.

ESD damage can range from subtle performance degradation to complete device failure. Precision integrated circuits may be more susceptible to damage because very small parametric changes could cause the device not to meet its published specifications.

PACKAGE/ORDERING INFORMATION

PRODUCT	PACKAGE-LEAD	PACKAGE DESIGNATOR ⁽¹⁾	SPECIFIED TEMPERATURE RANGE	PACKAGE MARKING	ORDERING NUMBER	TRANSPORT MEDIA, QUANTITY
REF2912	SOT23-3	DBZ	-40°C to +125°C	R29A	REF2912AIDBZT	Tape and Reel, 250
"	"	"	"	"	REF2912AIDBZR	Tape and Reel, 3000
REF2920	SOT23-3	DBZ	-40°C to +125°C	R29B	REF2920AIDBZT	Tape and Reel, 250
"	"	"	"	"	REF2920AIDBZR	Tape and Reel, 3000
REF2925	SOT23-3	DBZ	-40°C to +125°C	R29C	REF2925AIDBZT	Tape and Reel, 250
"	"	"	"	"	REF2925AIDBZR	Tape and Reel, 3000
REF2930	SOT23-3	DBZ	-40°C to +125°C	R29D	REF2930AIDBZT	Tape and Reel, 250
"	"	"	"	"	REF2930AIDBZR	Tape and Reel, 3000
REF2933	SOT23-3	DBZ	-40°C to +125°C	R29E	REF2933AIDBZT	Tape and Reel, 250
"	"	"	"	"	REF2933AIDBZR	Tape and Reel, 3000
REF2940	SOT23-3	DBZ	-40°C to +125°C	R29F	REF2940AIDBZT	Tape and Reel, 250
"	"	"	"	"	REF2940AIDBZR	Tape and Reel, 3000

NOTE: (1) For the most current specifications and package information, refer to our web site at www.ti.com.

ELECTRICAL CHARACTERISTICS

Boldface limits apply over the specified temperature range, T_A = -40°C to +125°C.

At T_A = +25°C, I_{LOAD} = 0mA, V_{IN} = 5V, unless otherwise noted.

PARAMETER	CONDITIONS	REF29xx			UNITS
		MIN	TYP	MAX	
REF2912-1.25V					
OUTPUT VOLTAGE Initial Accuracy	V _{OUT}	1.225	1.25	1.275 2	V %
NOISE Output Voltage Noise Voltage Noise	f = 0.1Hz to 10Hz f = 10Hz to 10kHz		20 42		μVp-p μVrms
LINE REGULATION	1.8V ≤ V _{IN} ≤ 5.5V		60	190	μV/V
REF2920					
OUTPUT VOLTAGE Initial Accuracy	V _{OUT}	2.007	2.048	2.089 2	V %
NOISE Output Voltage Noise Voltage Noise	f = 0.1Hz to 10Hz f = 10Hz to 10kHz		28 65		μVp-p μVrms
LINE REGULATION	V _{REF} + 50mV ≤ V _{IN} ≤ 5.5V		110	290	μV/V
REF2925					
OUTPUT VOLTAGE Initial Accuracy	V _{OUT}	2.450	2.50	2.550 2	V %
NOISE Output Voltage Noise Voltage Noise	f = 0.1Hz to 10Hz f = 10Hz to 10kHz		35 80		μVp-p μVrms
LINE REGULATION	V _{REF} + 50mV ≤ V _{IN} ≤ 5.5V		120	325	μV/V

ELECTRICAL CHARACTERISTICS (Cont.)

Boldface limits apply over the specified temperature range, $T_A = -40^{\circ}\text{C}$ to $+125^{\circ}\text{C}$.

At $T_A = +25^{\circ}\text{C}$, $I_{\text{LOAD}} = 0\text{mA}$, $V_{\text{IN}} = 5\text{V}$, unless otherwise noted.

PARAMETER	CONDITIONS	REF29xx			UNITS
		MIN	TYP	MAX	
REF2930					
OUTPUT VOLTAGE Initial Accuracy	V_{OUT}	2.940	3.0	3.06 2	V %
NOISE Output Voltage Noise Voltage Noise	$f = 0.1\text{Hz to }10\text{Hz}$ $f = 10\text{Hz to }10\text{kHz}$				$\mu\text{Vp-p}$ μVrms
LINE REGULATION	$V_{\text{REF}} + 50\text{mV} \leq V_{\text{IN}} \leq 5.5\text{V}$		120	375	$\mu\text{V/V}$
REF2933					
OUTPUT VOLTAGE Initial Accuracy	V_{OUT}	3.234	3.30	3.366 2	V %
NOISE Output Voltage Noise Voltage Noise	$f = 0.1\text{Hz to }10\text{Hz}$ $f = 10\text{Hz to }10\text{kHz}$		41 105		$\mu\text{Vp-p}$ μVrms
LINE REGULATION	$V_{\text{REF}} + 50\text{mV} \leq V_{\text{IN}} \leq 5.5\text{V}$		130	400	$\mu\text{V/V}$
REF2940					
OUTPUT VOLTAGE Initial Accuracy	V_{OUT}	4.014	4.096	4.178 2	V %
NOISE Output Voltage Noise Voltage Noise	$f = 0.1\text{Hz to }10\text{Hz}$ $f = 10\text{Hz to }10\text{kHz}$		45 128		$\mu\text{Vp-p}$ μVrms
LINE REGULATION	$V_{\text{REF}} + 50\text{mV} \leq V_{\text{IN}} \leq 5.5\text{V}$		160	410	$\mu\text{V/V}$
REF2912, REF2920, REF2925, REF2930, REF2933, REF2940					
OUTPUT VOLTAGE TEMP DRIFT ⁽²⁾	dV_{OUT}/dT	$-40^{\circ}\text{C} \leq T_A \leq +125^{\circ}\text{C}$		35 100	ppm/°C mA
OUTPUT CURRENT	I_{LOAD}				25
LONG-TERM STABILITY		0-1000 _H 1000-2000 _H		24 15	ppm ppm
LOAD REGULATION ⁽³⁾	$dV_{\text{OUT}}/dI_{\text{LOAD}}$	$0\text{mA} < I_{\text{LOAD}} < 25\text{mA}$, $V_{\text{IN}} = V_{\text{REF}} + 500\text{mV}$ ⁽¹⁾		3	100
THERMAL HYSTERESIS ⁽⁴⁾	dT			25	100
DROPOUT VOLTAGE	$V_{\text{IN}} - V_{\text{OUT}}$			1	50
SHORT-CIRCUIT CURRENT	I_{SC}			45	
TURN-ON SETTLING TIME		to 0.1% at $V_{\text{IN}} = 5\text{V}$ with $C_L = 0$		120	
POWER SUPPLY Voltage Over Temperature Quiescent Current Over Temperature	V_S I_Q	$I_L = 0$ $-40^{\circ}\text{C} \leq T_A \leq +125^{\circ}\text{C}$ $-40^{\circ}\text{C} \leq T_A \leq +125^{\circ}\text{C}$	$V_{\text{REF}} + 0.001$ ⁽⁵⁾ $V_{\text{REF}} + 0.05$		5.5 5.5 50 59
TEMPERATURE RANGE Specified Range Operating Range Storage Range Thermal Resistance SOT23-3 Surface-Mount	 θ_{JC} θ_{JA}				 -40 -40 -65 110 336
					 °C °C °C °C/W °C/W

NOTES: (1) Minimum supply voltage for REF2912 is 1.8V. (2) Box Method used to determine over temperature drift. (3) Typical value of load regulation reflects measurements using a force and sense contacts, see text "Load Regulation". (4) Thermal hysteresis procedure is explained in more detail in Applications Information section of data sheet. (5) For $I_L > 0$, see Typical Characteristic curves.

TYPICAL CHARACTERISTICS

At $T_A = +25^\circ\text{C}$, $V_{IN} = +5\text{V}$ power supply, REF2925 is used for typical characteristics, unless otherwise noted.

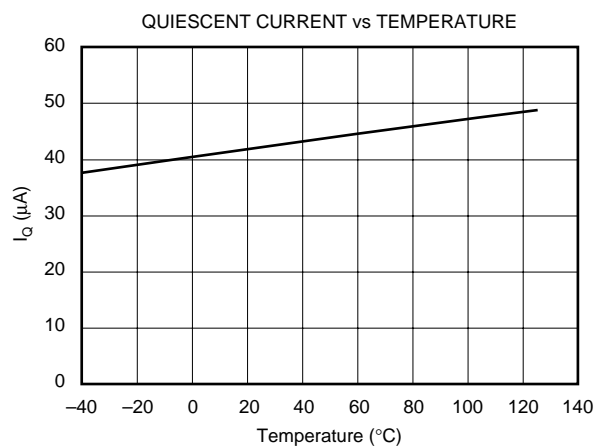
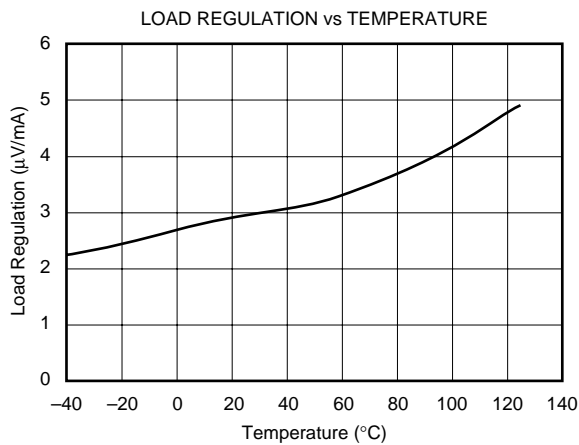
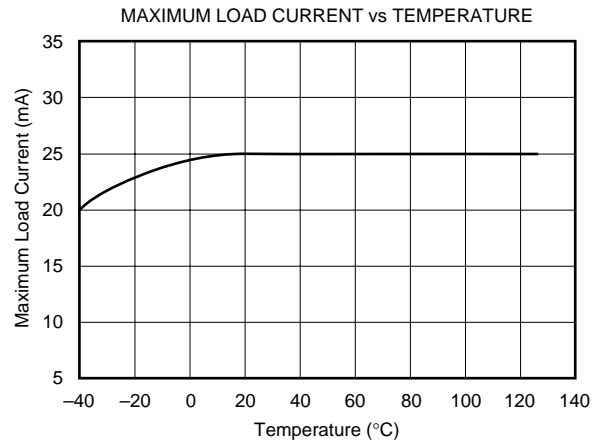
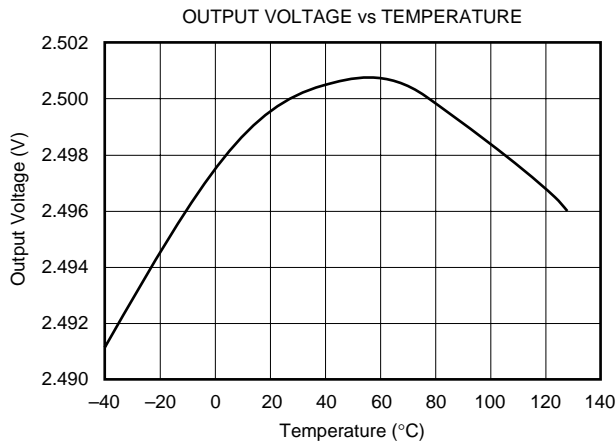
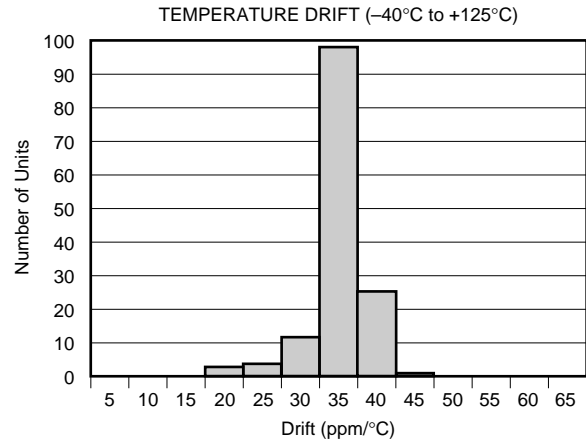
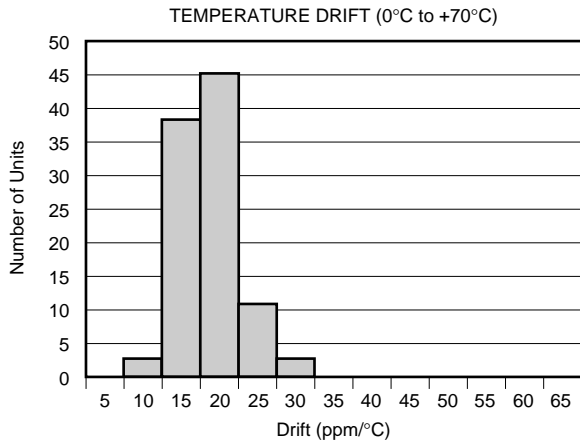

TYPICAL CHARACTERISTICS (Cont.)

At $T_A = +25^\circ\text{C}$, $V_{IN} = +5\text{V}$ power supply, REF2925 is used for typical characteristics, unless otherwise noted.

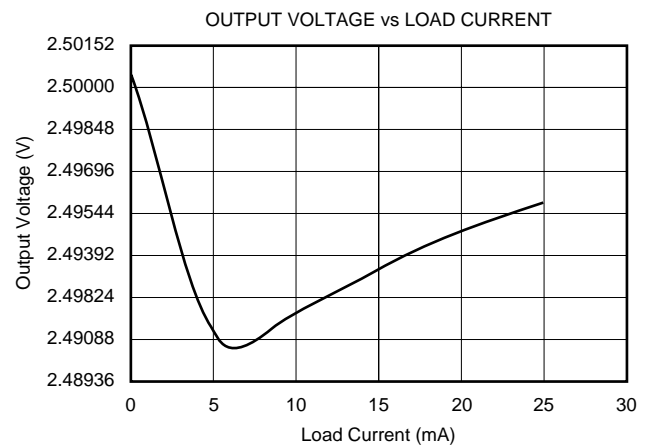
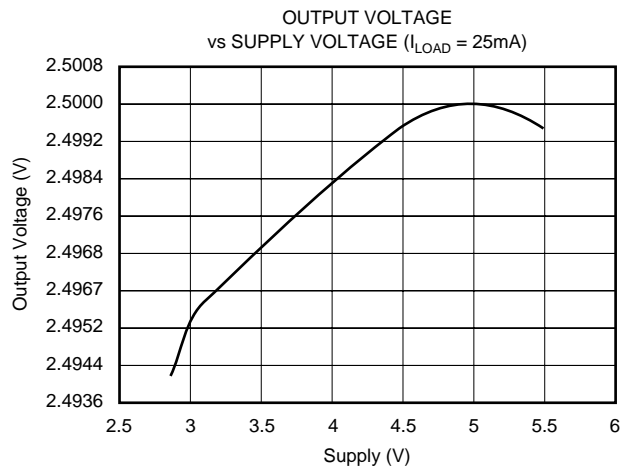
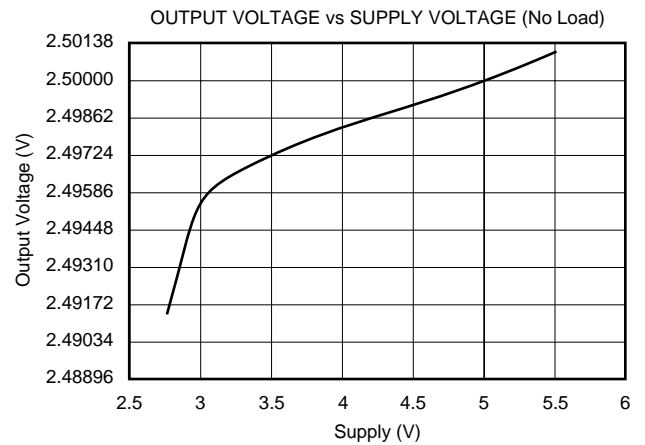
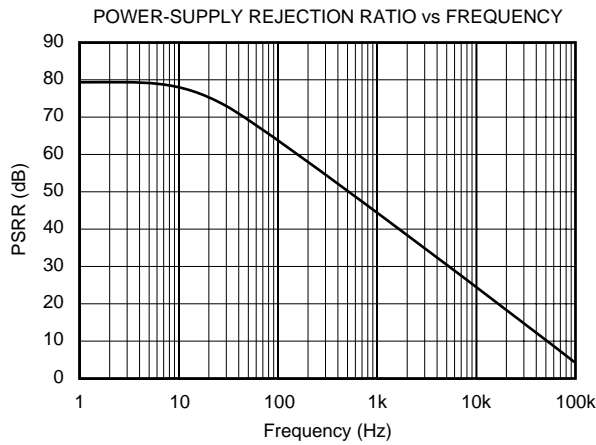
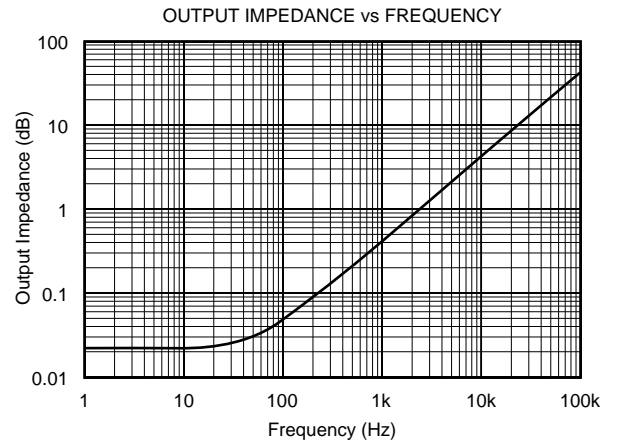
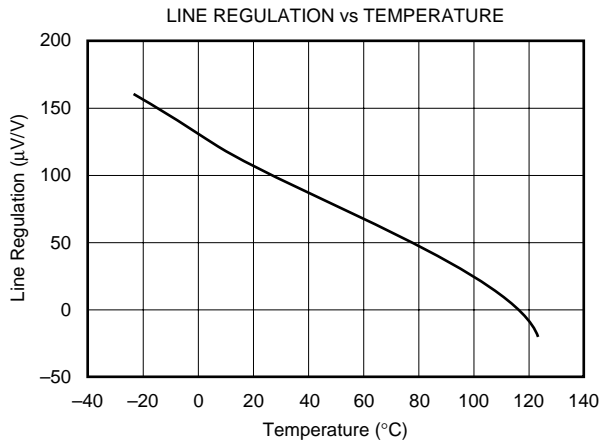

TYPICAL CHARACTERISTICS (Cont.)

At $T_A = +25^\circ\text{C}$, $V_{IN} = +5\text{V}$ power supply, REF2925 is used for typical characteristics, unless otherwise noted.

STEP RESPONSE, $C_L = 0$, 3V START-UP

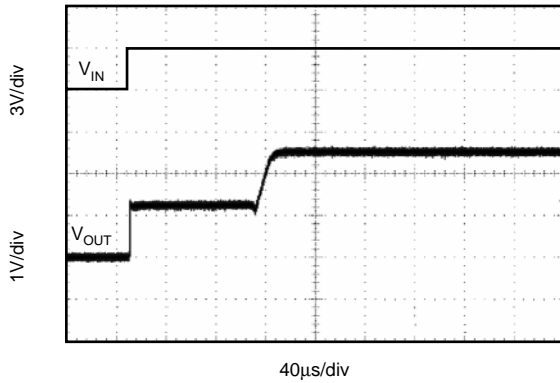

STEP RESPONSE, $C_L = 0$, 5V START-UP

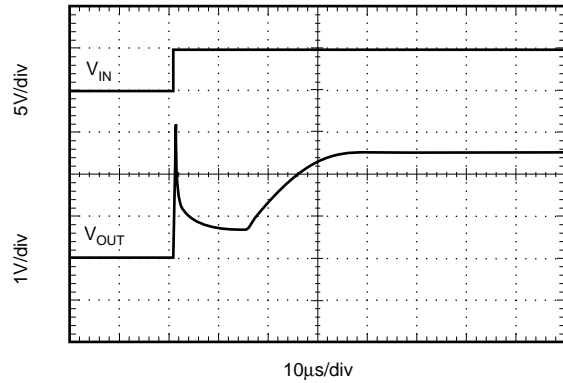

LINE TRANSIENT RESPONSE

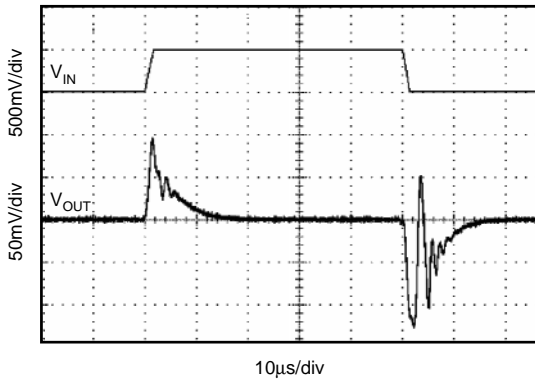

0-1mA LOAD TRANSIENT ($C_L = 0$)

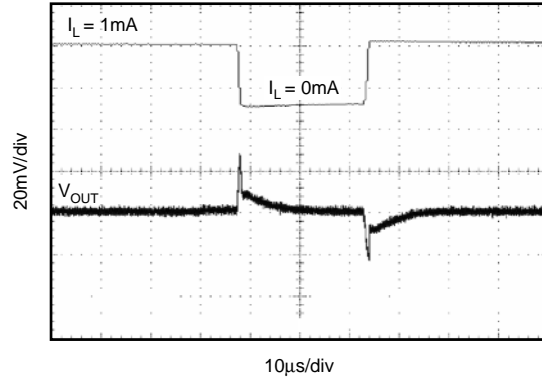

0-5mA LOAD TRANSIENT ($C_L = 0$)

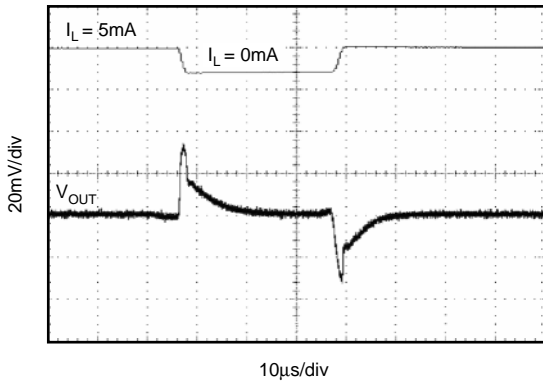

1-6mA LOAD TRANSIENT ($C_L = 1\mu\text{F}$)

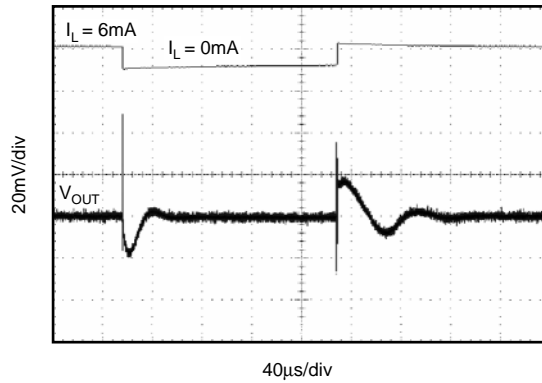

TYPICAL CHARACTERISTICS (Cont.)

At $T_A = +25^\circ\text{C}$, $V_{IN} = +5\text{V}$ power supply, REF2925 is used for typical characteristics, unless otherwise noted.

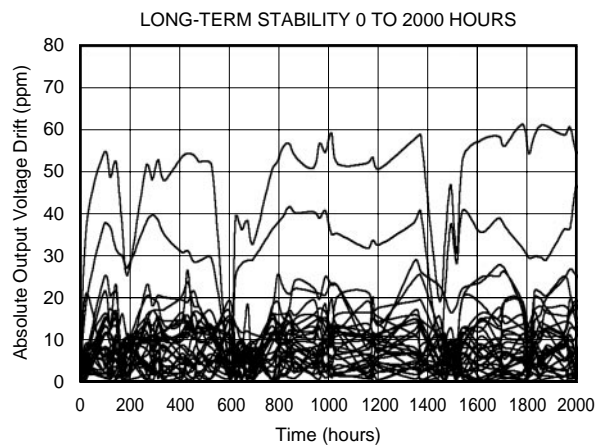
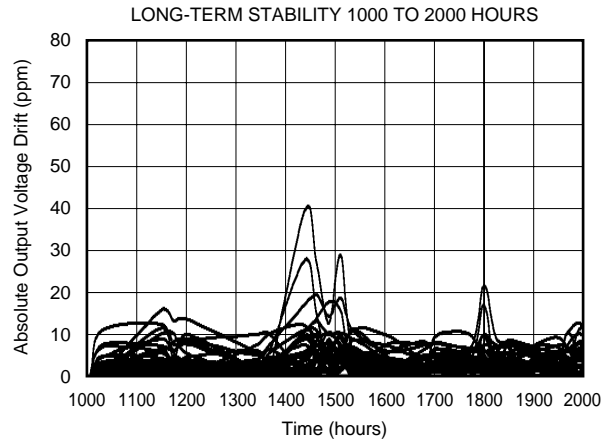
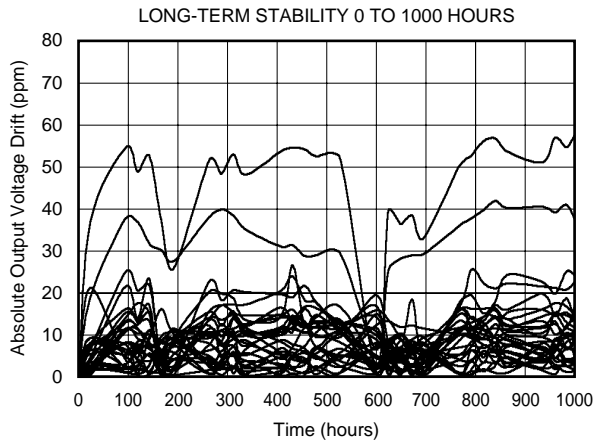
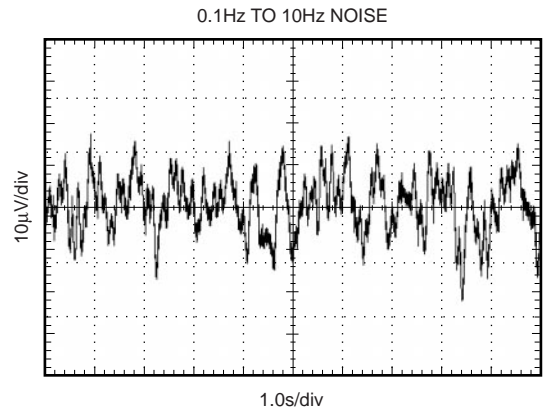
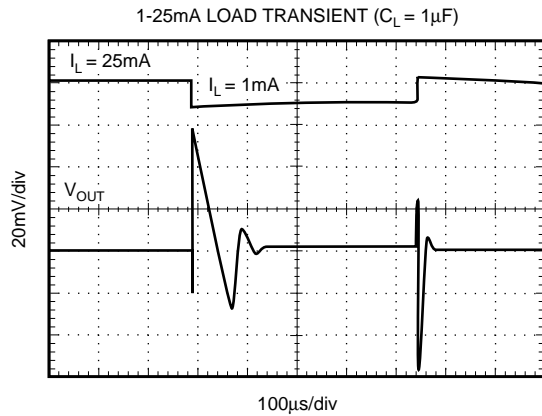

THEORY OF OPERATION

The REF29xx is a series, CMOS, precision bandgap voltage reference. Its basic topology is shown in Figure 1. The transistors Q_1 , and Q_2 , are biased such that the current density of Q_1 is greater than that of Q_2 . The difference of the two base-emitter voltages, $V_{be1} - V_{be2}$, has a positive temperature coefficient and is forced across resistor R_1 . This voltage is gained up and added to the base-emitter voltage of Q_2 , which has a negative coefficient. The resulting output voltage is virtually independent of temperature. The curvature of the bandgap voltage, as seen in the typical curve, "Output Voltage vs Temperature", is due to the slightly nonlinear temperature coefficient of the base-emitter voltage of Q_2 .

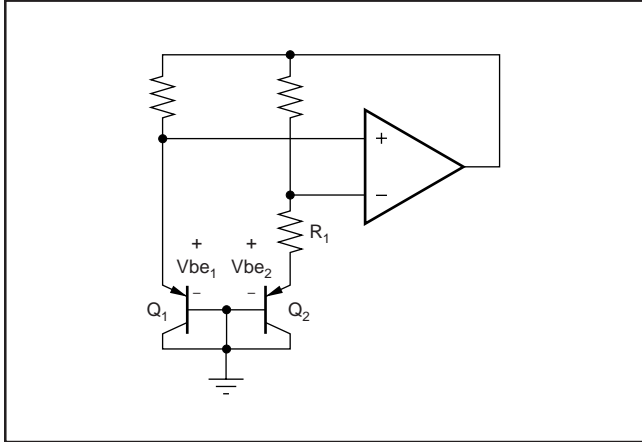

FIGURE 1. Simplified Schematic of Bandgap Reference.

APPLICATION INFORMATION

The REF29xx does not require a load capacitor, and is stable with any capacitive load. Figure 2 shows typical connections required for operation of the REF29xx. A supply bypass capacitor of $0.47\mu\text{F}$ is recommended.

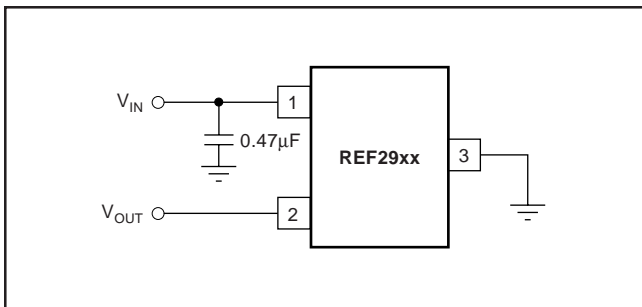

FIGURE 2. Typical Connections for Operating REF29xx.

SUPPLY VOLTAGE

The REF30xx family of references features an extremely low dropout voltage. With the exception of the REF2912, which has a minimum supply requirement of 1.8V, the REF29xx can be operated with a supply of only 1mV above the output voltage in an unloaded condition. For loaded conditions, a typical dropout voltage versus load is shown on the cover page.

The REF29xx features a low quiescent current, which is extremely stable over changes in both temperature and supply. The typical room temperature quiescent current is $42\mu\text{A}$, and the maximum quiescent current over temperature is just $59\mu\text{A}$. Additionally, the quiescent current typically changes less than $2.5\mu\text{A}$ over the entire supply range, as shown in Figure 3.

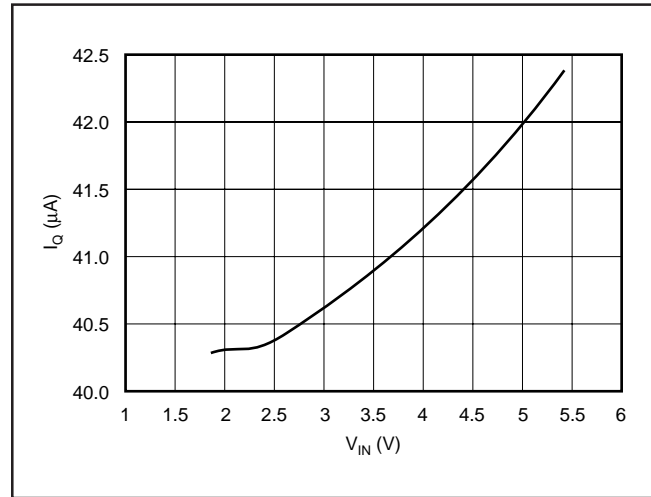

FIGURE 3. Supply Current vs Supply Voltage.

Supply voltages below the specified levels can cause the REF29xx to momentarily draw currents greater than the typical quiescent current. Using a power supply with a fast rising edge and low output impedance easily prevents this.

THERMAL HYSTERESIS

Thermal hysteresis for the REF29xx is defined as the change in output voltage after operating the device at 25°C , cycling the device through the specified temperature range, and returning to 25°C , and can be expressed as:

$$V_{\text{HYST}} = \left(\frac{\text{abs}|V_{\text{PRE}} - V_{\text{POST}}|}{V_{\text{NOM}}} \right) \cdot 10^6 (\text{ppm})$$

Where: V_{HYST} = Calculated hysteresis

V_{PRE} = Output voltage measured at 25°C pre-temperature cycling

V_{POST} = Output voltage measured when device has been operated at 25°C , cycled through specified range -40°C to $+125^\circ\text{C}$ and returned to operation at 25°C

TEMPERATURE DRIFT

The REF30xx is designed to exhibit minimal drift error, defined as the change in output voltage over varying temperature. Using the 'box' method of drift measurement, the REF29xx features a typical drift coefficient of 20ppm from 0°C to 70°C —the primary temperature range of use for many applications. For industrial temperature ranges of -40°C to 125°C , the REF30xx family drift increases to a typical value of 50ppm.

NOISE PERFORMANCE

The REF29xx generates noise less than $50\mu\text{Vp-p}$ between frequencies of 0.1Hz to 10Hz, and can be seen in the Typical Characteristic Curve “0.1 to 10Hz Voltage Noise”. The noise voltage of the REF29xx increases with output voltage and operating temperature. Additional filtering may be used to improve output noise levels, although care should be taken to ensure the output impedance does not degrade AC performance.

LONG TERM STABILITY

Long term stability refers to the change of the output voltage of a reference over a period of months or years. This effect lessens as time progresses as is apparent by the long term stability curves. The typical drift value for the REF29xx is 24ppm from 0-1000 hours, and 15ppm from 1000-2000 hours. This parameter is characterized by measuring 30 units at regular intervals for a period of 2000 hours.

LOAD REGULATION

Load regulation is defined as the change in output voltage due to changes in load current. Load regulation for the REF29xx is measured using force and sense contacts as pictured in Figure 4. The force and sense lines tied to the

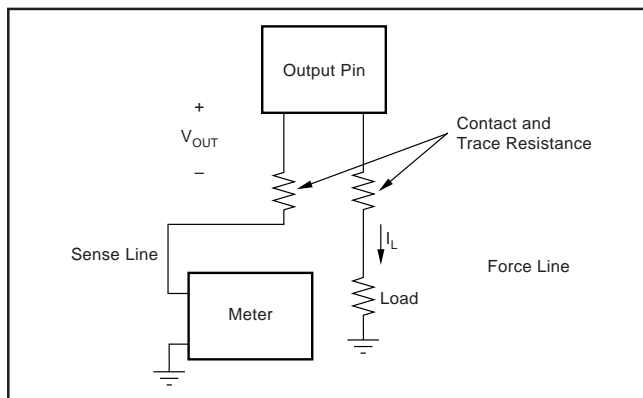

FIGURE 4. Accurate Load Regulation of REF29xx.

contact area of the output pin reduce the impact of contact and trace resistance, resulting in accurate measurement of the load regulation contributed solely by the REF29xx. For applications requiring improved load regulation, force and sense lines should be used.

APPLICATION CIRCUITS

Negative Reference Voltage

For applications requiring a negative and positive reference voltage, the OPA703 and REF29xx can be used to provide a dual supply reference from a $\pm 5\text{V}$ supply. Figure 5 shows the REF2925 used to provide a $\pm 2.5\text{V}$ supply reference voltage. The low offset voltage and low drift of the OPA703 complement the low drift performance of the REF29xx to provide an accurate solution for split-supply applications.

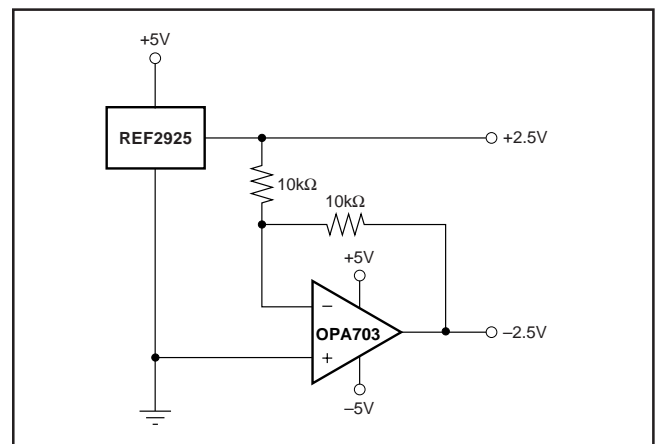

FIGURE 5. REF2925 Combined with OPA703 to Create Positive and Negative Reference Voltages.

DATA ACQUISITION

Often data acquisition systems require stable voltage references to maintain necessary accuracy. The REF29xx family features stability and a wide range of voltages suitable for most micro-controllers and data converters. See Figure 6 for a basic data acquisition system.

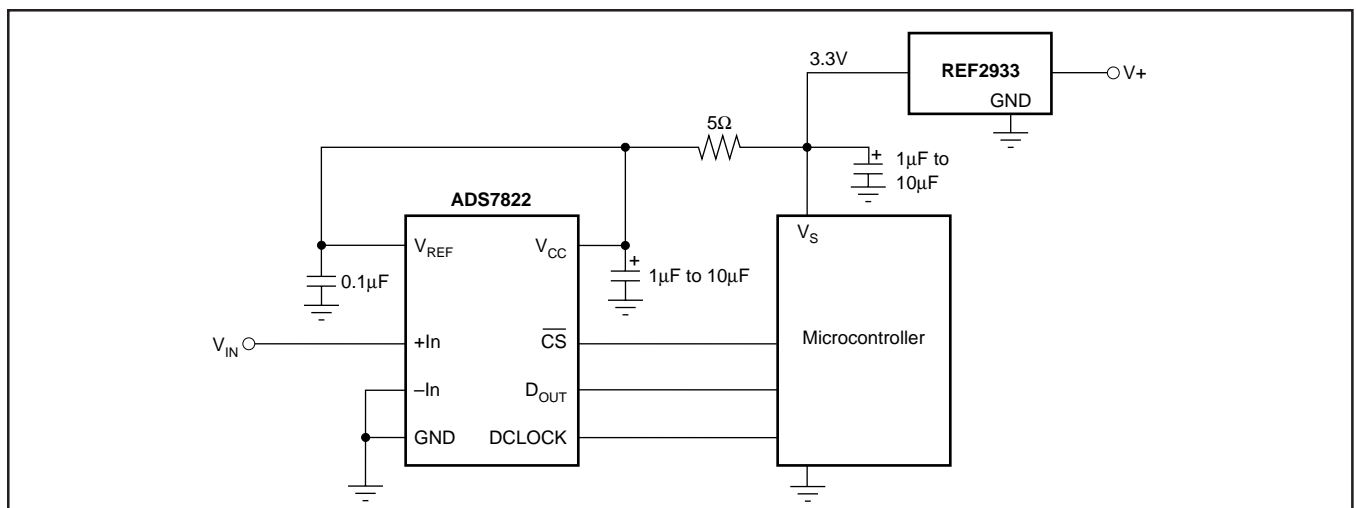
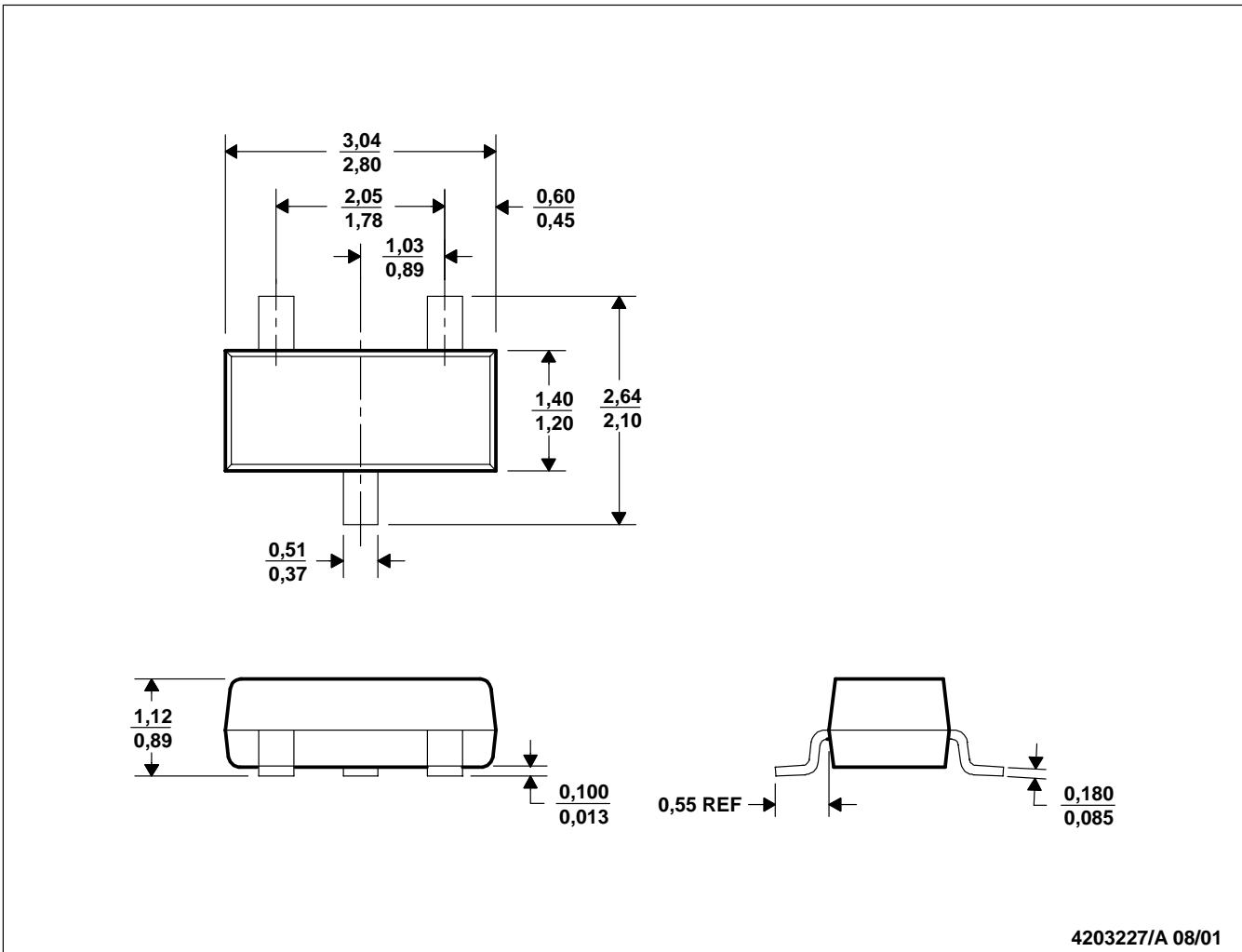

FIGURE 6. Basic Data Acquisition System 1.

DBZ (R-PDSO-G3)

PLASTIC SMALL-OUTLINE



- NOTES:
- A. All linear dimensions are in millimeters.
 - B. This drawing is subject to change without notice.
 - C. Dimensions are inclusive of plating.
 - D. Dimensions are exclusive of mold flash and metal burr.

IMPORTANT NOTICE

Texas Instruments Incorporated and its subsidiaries (TI) reserve the right to make corrections, modifications, enhancements, improvements, and other changes to its products and services at any time and to discontinue any product or service without notice. Customers should obtain the latest relevant information before placing orders and should verify that such information is current and complete. All products are sold subject to TI's terms and conditions of sale supplied at the time of order acknowledgment.

TI warrants performance of its hardware products to the specifications applicable at the time of sale in accordance with TI's standard warranty. Testing and other quality control techniques are used to the extent TI deems necessary to support this warranty. Except where mandated by government requirements, testing of all parameters of each product is not necessarily performed.

TI assumes no liability for applications assistance or customer product design. Customers are responsible for their products and applications using TI components. To minimize the risks associated with customer products and applications, customers should provide adequate design and operating safeguards.

TI does not warrant or represent that any license, either express or implied, is granted under any TI patent right, copyright, mask work right, or other TI intellectual property right relating to any combination, machine, or process in which TI products or services are used. Information published by TI regarding third-party products or services does not constitute a license from TI to use such products or services or a warranty or endorsement thereof. Use of such information may require a license from a third party under the patents or other intellectual property of the third party, or a license from TI under the patents or other intellectual property of TI.

Reproduction of information in TI data books or data sheets is permissible only if reproduction is without alteration and is accompanied by all associated warranties, conditions, limitations, and notices. Reproduction of this information with alteration is an unfair and deceptive business practice. TI is not responsible or liable for such altered documentation.

Resale of TI products or services with statements different from or beyond the parameters stated by TI for that product or service voids all express and any implied warranties for the associated TI product or service and is an unfair and deceptive business practice. TI is not responsible or liable for any such statements.

Mailing Address:

Texas Instruments
Post Office Box 655303
Dallas, Texas 75265