



SBAS221C – DECEMBER 2001 – REVISED JULY 2002

30mA SWITCHED-CAP BUCK/BOOST CONVERTER

FEATURES

- WIDE INPUT RANGE: 1.8V to 5.5V
- AUTOMATIC STEP-UP/STEP-DOWN OPERATION
- LOW INPUT CURRENT RIPPLE
- LOW OUTPUT VOLTAGE RIPPLE
- MINIMUM NUMBER OF EXTERNAL COMPONENTS—NO INDUCTORS
- 1MHz INTERNAL OSCILLATOR ALLOWS SMALL CAPACITORS
- “SHUTDOWN” MODE
- THERMAL AND CURRENT LIMIT PROTECTION
- FIVE OUTPUT VOLTAGES AVAILABLE: 5.0V, 3.3V, 3.0V, 2.7V, 2.5V
- SMALL PACKAGE: SOT23-6
- EVMS AVAILABLE: REG710EVM-33, REG710EVM-50

APPLICATIONS

- SMART CARD READERS
- SIM CARD SUPPLIES
- CELLULAR PHONES
- PORTABLE COMMUNICATION DEVICES
- PERSONAL DIGITAL ASSISTANTS
- NOTEBOOK AND PALM-TOP COMPUTERS
- MODEMS
- ELECTRONIC GAMES
- HANDHELD METERS
- PCMCIA CARDS
- CARD BUSES
- WHITE LED DRIVER
- LCD DISPLAYS
- BATTERY BACKUP SUPPLIES

DESCRIPTION

The REG710 is a switched capacitor voltage converter, which produces a regulated, low-ripple output voltage from an unregulated input voltage. A wide-input supply voltage of 1.8V to 5.5V makes the REG710 ideal for a variety of battery sources, such as single cell Li-Ion, or two and three cell Nickel or Alkaline based chemistries.

The input voltage may vary above and below the output voltage and the output will remain in regulation. It works equally well for step-up or step-down without the need for an inductor, providing low EMI DC/DC conversion. The high switching frequency allows the use of small surface-mount capacitors, saving board space and reducing cost. The REG710 is thermally protected and current limited, protecting the load and the regulator during fault conditions. Typical ground pin current (quiescent current) is 65µA with no load, and less than 1µA in shutdown mode. This regulator comes in a small SOT23-6 package.

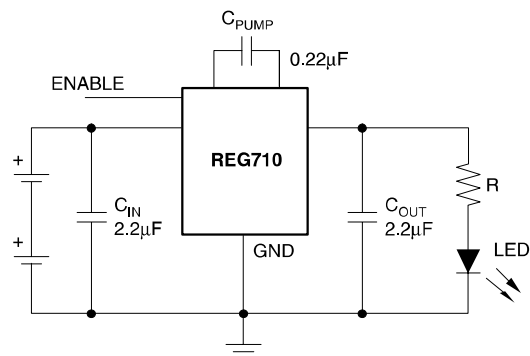

REG710 Used in White LED Backlight Application.

ABSOLUTE MAXIMUM RATINGS(1)

Supply Voltage	-0.3V to +6.0V
Enable Input	-0.3V to V_{IN}
Output Short-Circuit Duration	Indefinite
Operating Temperature Range	-55°C to +125°C
Storage Temperature Range	-65°C to +150°C
Junction Temperature	-55°C to +150°C
Lead Temperature (soldering, 3s)	+240°C

NOTE: (1) Stresses above these ratings may cause permanent damage. Exposure to absolute maximum conditions for extended periods may degrade device reliability.

ELECTROSTATIC DISCHARGE SENSITIVITY

This integrated circuit can be damaged by ESD. Texas Instruments recommends that all integrated circuits be handled with appropriate precautions. Failure to observe proper handling and installation procedures can cause damage.

ESD damage can range from subtle performance degradation to complete device failure. Precision integrated circuits may be more susceptible to damage because very small parametric changes could cause the device not to meet its published specifications.

PACKAGE ORDERING INFORMATION

PRODUCT	OUTPUT VOLTAGE	PACKAGE-LEAD	PACKAGE DESIGNATOR(1)	SPECIFIED TEMPERATURE RANGE	PACKAGE MARKING(2)	ORDERING NUMBER	TRANSPORT MEDIA, QUANTITY
5V Output REG710NA-5	5.0V	SOT23-6	DBV	-40°C to +85°C	R10B	REG710NA-5/250 REG710NA-5/3K	Tape and Reel, 250 Tape and Reel, 3000
3.3V Output REG710NA-3.3	3.3V	SOT23-6	DBV	-40°C to +85°C	R10C	REG710NA-3.3/250 REG710NA-3.3/3K	Tape and Reel, 250 Tape and Reel, 3000
3V Output REG710NA-3	3.0V	SOT23-6	DBV	-40°C to +85°C	R10D	REG710NA-3/250 REG710NA-3/3K	Tape and Reel, 250 Tape and Reel, 3000
2.7V Output REG710NA-2.7	2.7V	SOT23-6	DBV	-40°C to +85°C	R10F	REG710NA-2.7/250 REG710NA-2.7/3K	Tape and Reel, 250 Tape and Reel, 3000
2.5V Output REG710NA-2.5	2.5V	SOT23-6	DBV	-40°C to +85°C	R10G	REG710NA-2.5/250 REG710NA-2.5/3K	Tape and Reel, 250 Tape and Reel, 3000

NOTES: (1) For the most current specifications and product information, refer to our web site at www.ti.com. (2) Voltage will be marked on reel.

PIN CONFIGURATION

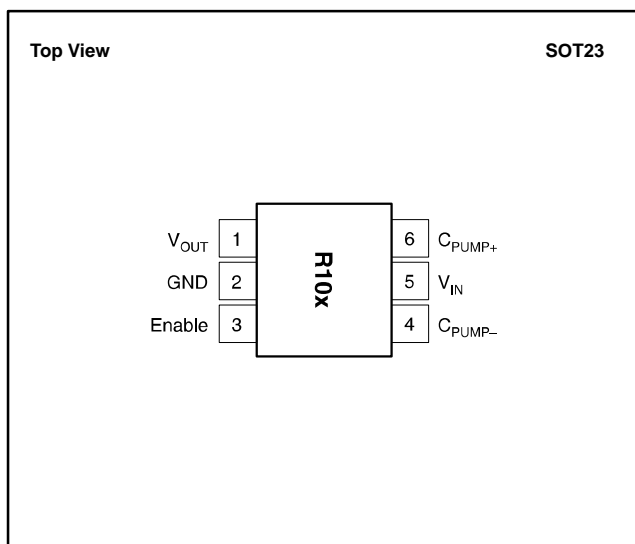

SIMPLIFIED BLOCK DIAGRAM

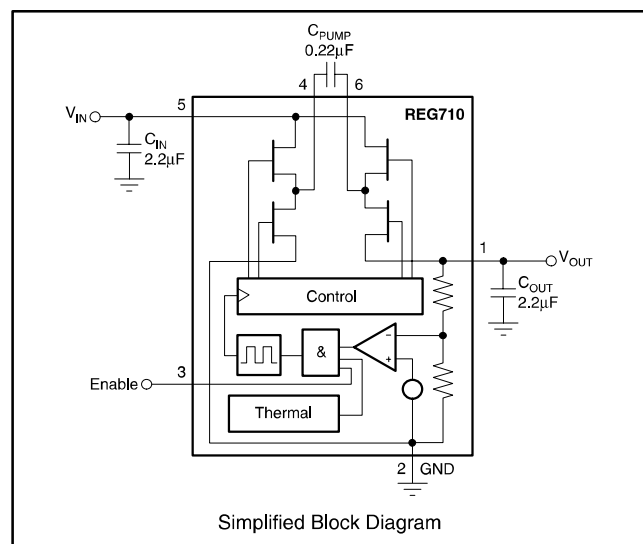

ELECTRICAL CHARACTERISTICS

Boldface limits apply over the specified temperature range, $T_A = -40\text{ C to }+85\text{ C}$

At $T_A = +25^\circ\text{C}$, $V_{IN} = V_{OUT}/2 + 0.75\text{V}$, $I_{OUT} = 5\text{mA}$, $C_{IN} = C_{OUT} = 2.2\mu\text{F}$, $C_{PUMP} = 0.22\mu\text{F}$, $V_{ENABLE} = 1.3\text{V}$, unless otherwise noted(1).

PARAMETER	CONDITIONS	REG710NA			UNITS
		MIN	TYP	MAX	
INPUT VOLTAGE					
Tested Startup					
REG710-5	See conditions under "output voltage" with a resistive load not lower than typical V_{OUT}/I_{OUT} .	2.7		5.5	V
All Other Models		1.8		5.5	V
OUTPUT VOLTAGE					
REG710-5	$I_{OUT} \leq 10\text{mA}$, $2.7\text{V} \leq V_{IN} \leq 5.5\text{V}$ $I_{OUT} \leq 30\text{mA}$, $3.0\text{V} \leq V_{IN} \leq 5.5\text{V}$ $I_{OUT} \leq 60\text{mA}$, $3.3\text{V} \leq V_{IN} \leq 4.2\text{V}$, $T_A = -40^\circ\text{C to }+75^\circ\text{C}$	4.7	5.0	5.3	V
		4.7	5.0	5.3	V
		4.6	5.0	5.4	V
REG710-3.3	$I_{OUT} \leq 10\text{mA}$, $1.8\text{V} \leq V_{IN} \leq 5.5\text{V}$ $I_{OUT} \leq 30\text{mA}$, $2.2\text{V} \leq V_{IN} \leq 5.5\text{V}$	3.10	3.3	3.50	V
		3.10	3.3	3.50	V
REG710-3	$I_{OUT} \leq 10\text{mA}$, $1.8\text{V} \leq V_{IN} \leq 5.5\text{V}$ $I_{OUT} \leq 30\text{mA}$, $2.2\text{V} \leq V_{IN} \leq 5.5\text{V}$	2.82	3.0	3.18	V
		2.82	3.0	3.18	V
REG710-2.7	$I_{OUT} \leq 10\text{mA}$, $1.8\text{V} \leq V_{IN} \leq 5.5\text{V}$ $I_{OUT} \leq 30\text{mA}$, $2.0\text{V} \leq V_{IN} \leq 5.5\text{V}$	2.54	2.7	2.86	V
		2.54	2.7	2.86	V
REG710-2.5	$I_{OUT} \leq 10\text{mA}$, $1.8\text{V} \leq V_{IN} \leq 5.5\text{V}$ $I_{OUT} \leq 30\text{mA}$, $2.0\text{V} \leq V_{IN} \leq 5.5\text{V}$	2.35	2.5	2.65	V
		2.35	2.5	2.65	V
OUTPUT CURRENT					
Nominal		30			mA
Short Circuit(2)			100		mA
OSCILLATOR FREQUENCY(3)					
			1.0		MHz
EFFICIENCY(4)					
	$I_{OUT} = 10\text{mA}$, $V_{IN} = 1.8\text{V}$, REG710-3.3		90		%
RIPPLE VOLTAGE(1)					
	$I_{OUT} = 30\text{mA}$		35		mVp-p
ENABLE CONTROL					
	$V_{IN} = 1.8\text{V to }5.5\text{V}$				
Logic High Input Voltage		1.3		V_{IN}	V
Logic Low Input Voltage		-0.2		0.4	V
Logic High Input Current				100	nA
Logic Low Input Current				100	nA
THERMAL SHUTDOWN					
Shutdown Temperature			160		$^\circ\text{C}$
Shutdown Recovery			140		$^\circ\text{C}$
SUPPLY CURRENT					
(Quiescent Current)	$I_{OUT} = 0\text{mA}$		65	100	μA
In Shutdown Mode	$V_{IN} = 1.8\text{V to }5.5\text{V}$, Enable = 0V		0.01	1	μA
TEMPERATURE RANGE					
Specification Ambient Temperature	T_A	-40		+85	$^\circ\text{C}$
Operating Ambient Temperature	T_A	-55		+125	$^\circ\text{C}$
Storage Ambient Temperature	T_A	-65		+150	$^\circ\text{C}$
Thermal Resistance, θ_{JA}	SOT23-6		200		$^\circ\text{C/W}$

NOTES (1): Effective Series Resistance (ESR) of capacitors is $< 0.1\Omega$. (2) The supply current is twice the output short-circuit current. (3) The converter regulates by enabling and disabling periods of switching cycles. The switching frequency is the oscillator frequency during an active period. (4) See efficiency curves for other V_{IN}/V_{OUT} configurations.

TYPICAL CHARACTERISTICS

At $T_A = +25^\circ\text{C}$, $V_{IN} = V_{OUT}/2 + 0.75\text{V}$, $I_{OUT} = 5\text{mA}$, $C_{IN} = C_{OUT} = 2.2\mu\text{F}$, $C_{PUMP} = 0.22\mu\text{F}$, $V_{ENABLE} = 1.3\text{V}$, unless otherwise noted.

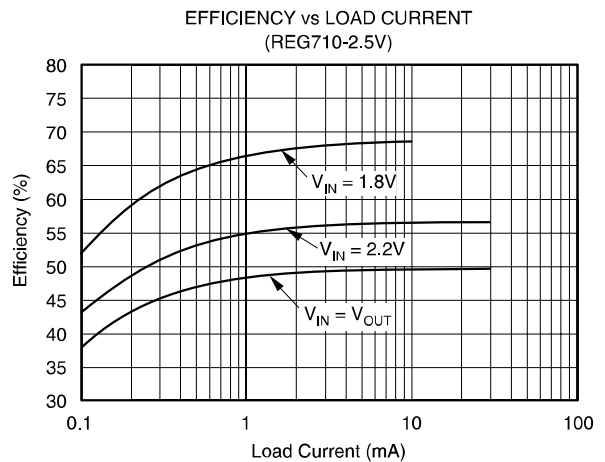
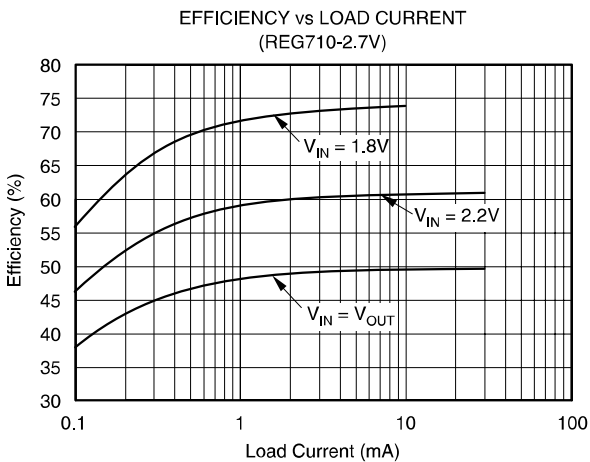
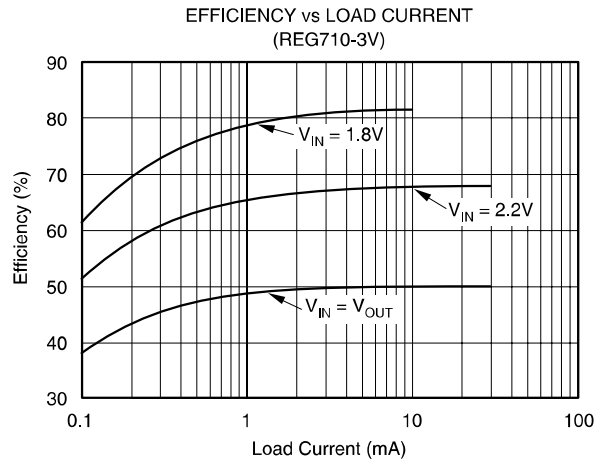
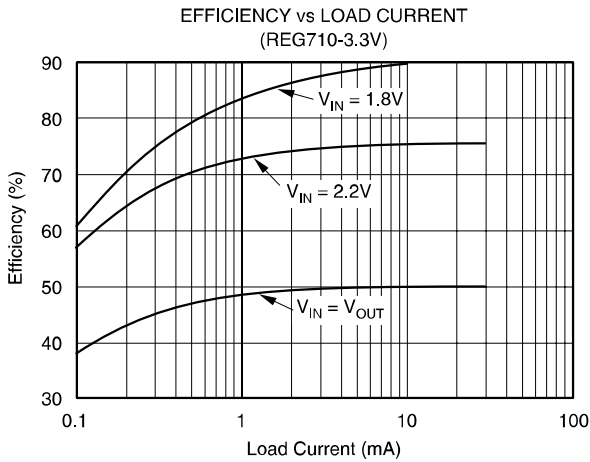
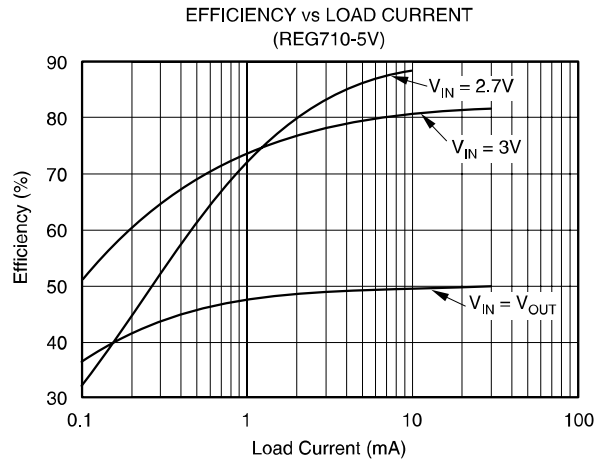
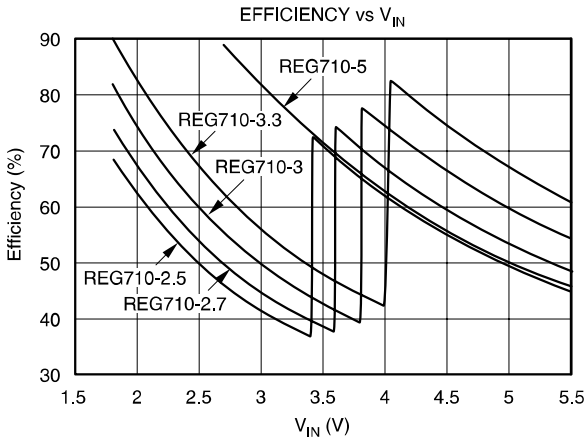

TYPICAL CHARACTERISTICS (Cont.)

At $T_A = +25^\circ\text{C}$, $V_{IN} = V_{OUT}/2 + 0.75\text{V}$, $I_{OUT} = 5\text{mA}$, $C_{IN} = C_{OUT} = 2.2\mu\text{F}$, $C_{PUMP} = 0.22\mu\text{F}$, $V_{ENABLE} = 1.3\text{V}$, unless otherwise noted.

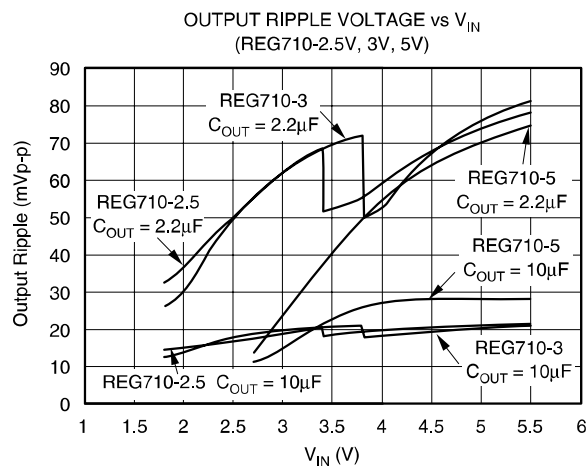
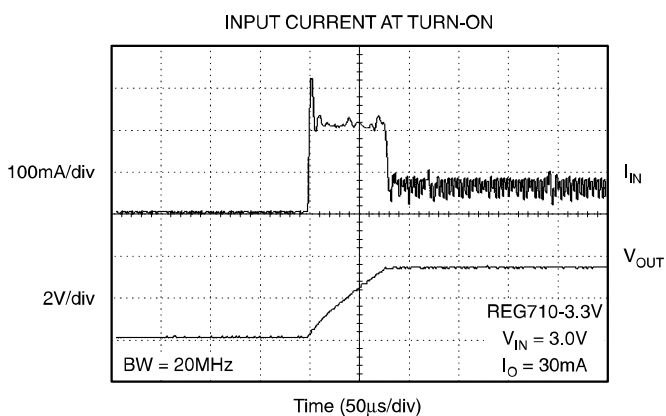
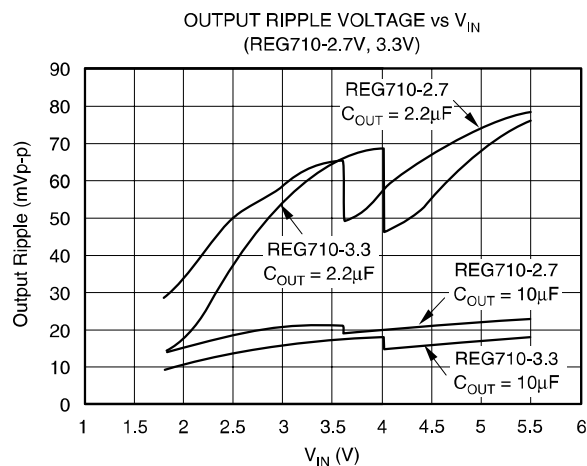
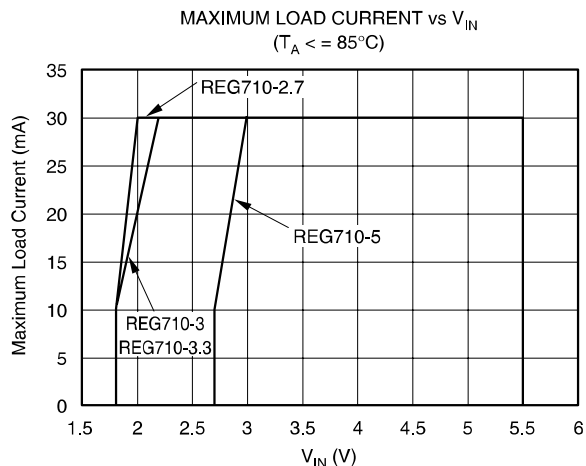
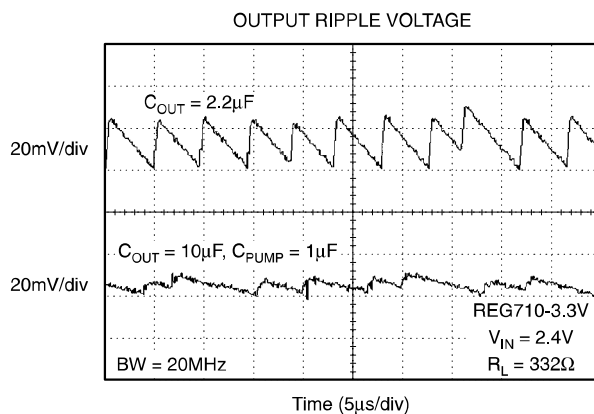
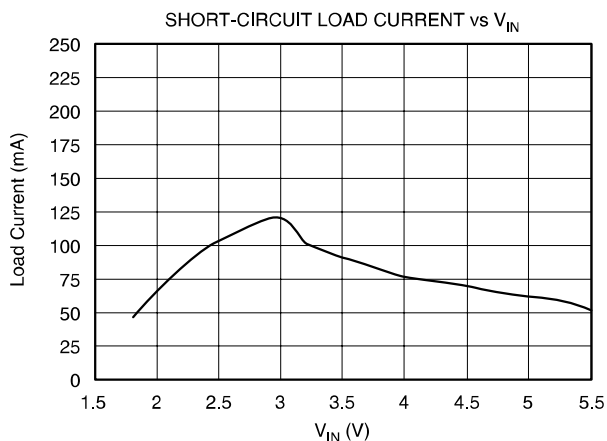

TYPICAL CHARACTERISTICS (Cont.)

At $T_A = +25^\circ\text{C}$, $V_{IN} = V_{OUT}/2 + 0.75\text{V}$, $I_{OUT} = 5\text{mA}$, $C_{IN} = C_{OUT} = 2.2\mu\text{F}$, $C_{PUMP} = 0.22\mu\text{F}$, $V_{ENABLE} = 1.3\text{V}$, unless otherwise noted.

SUPPLY CURRENT vs TEMPERATURE
(No Load)

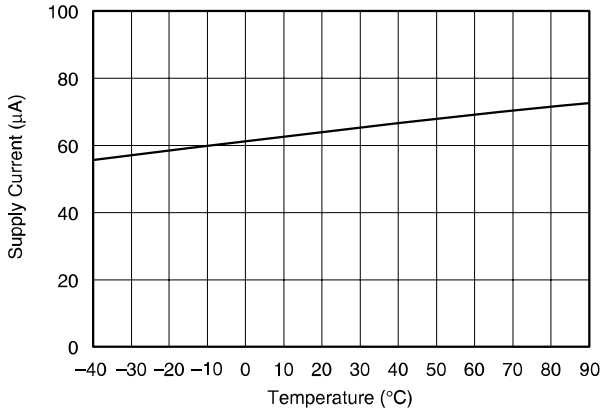

LOAD TRANSIENT RESPONSE

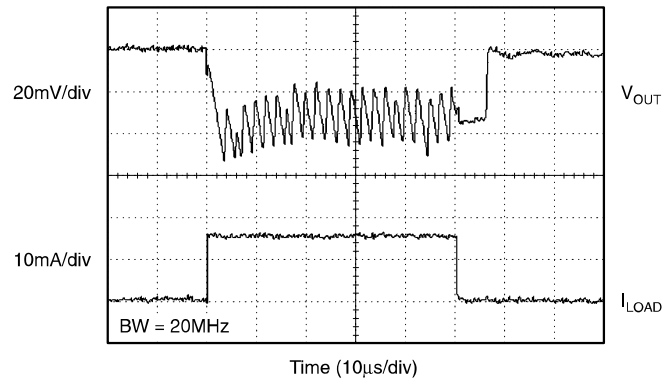

SUPPLY CURRENT vs TEMPERATURE
(Not Enabled)

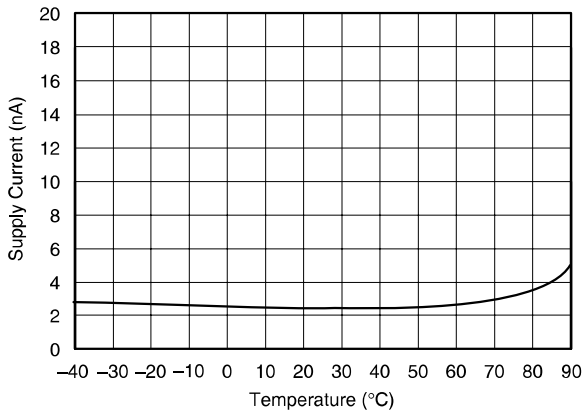

LINE TRANSIENT RESPONSE

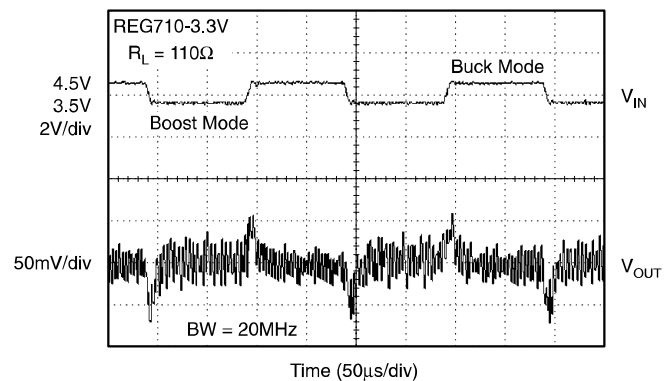

OUTPUT VOLTAGE vs TEMPERATURE

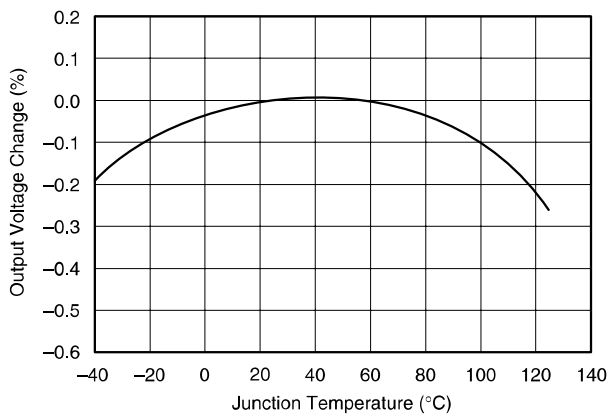

OUTPUT VOLTAGE DRIFT HISTOGRAM

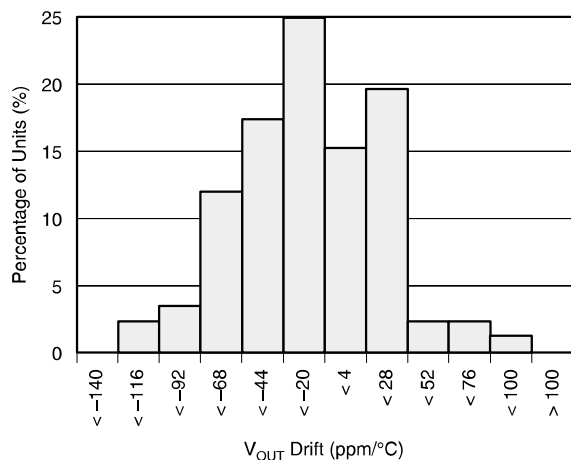

THEORY OF OPERATION

The REG710 regulated charge pump provides a regulated output voltage for input voltages ranging from less than the output to greater than the output. This is accomplished by automatic mode switching within the device. When the input voltage is greater than the required output, the unit functions as a variable frequency switch-mode regulator. This operation is shown in Figure 1. Transistors Q_1 and Q_3 are held off, Q_4 is on, and Q_2 is switched as needed to maintain a regulated output voltage.

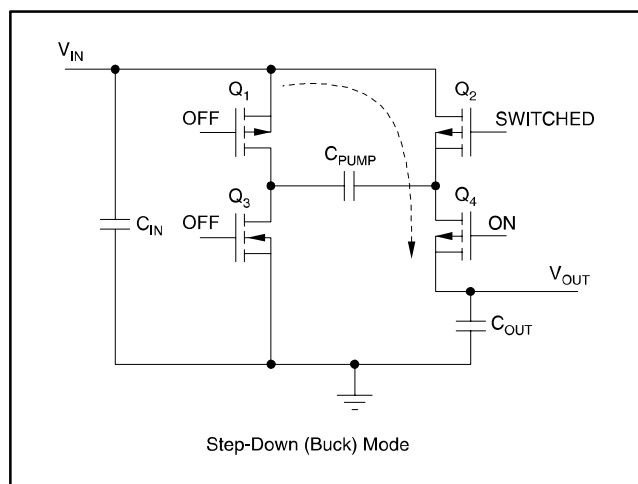

FIGURE 1: Simplified Schematic of the REG710 Operating in the Step-Down Mode.

When the input voltage is less than the required output voltage, the device switches to a step-up or boost mode of operation, as shown in Figure 2.

A conversion clock of 50% duty cycle is generated. During the first half cycle the FET switches are configured as shown in Figure 2A, and C_{PUMP} charges to V_{OUT} .

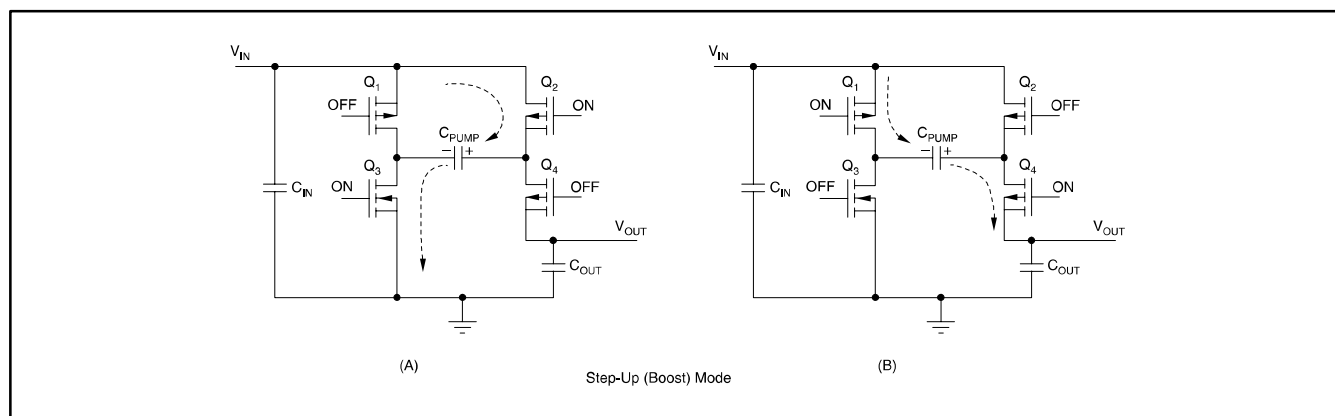

FIGURE 2: Simplified Schematic of the REG710 Operating in the Step-Up or Boost Mode.

During the second half cycle the FET switches are configured as shown in Figure 2B, and the voltage on C_{PUMP} is added to V_{OUT} . The output voltage is regulated by skipping clock cycles as necessary.

PEAK CURRENT REDUCTION

In normal operation, the charging of the pump and output capacitors usually leads to relatively high peak input currents which can be much higher than that of the average load current. The regulator incorporates circuitry to limit the input peak current, lowering the total EMI production of the device and lowering output voltage ripple and input current ripple. Input capacitor (C_{IN}) supplies most of the charge required by input current peaks.

PROTECTION

The regulator has thermal shutdown circuitry that protects it from damage caused by overload conditions. The thermal protection circuitry disables the output when the junction temperature reached approximately 160°C , allowing the device to cool. When the junction temperature cools to approximately 140°C , the output circuitry is automatically reenabled. Continuously running the regulator into thermal shutdown can degrade reliability. The regulator also provides current limit to protect itself and the load.

SHUTDOWN MODE

A control pin on the regulator can be used to place the device into an energy-saving shutdown mode. In this mode, the output is disconnected from the input as long as V_{IN} is greater than or equal to minimum V_{IN} and the input quiescent current is reduced to $1\mu\text{A}$ maximum.

CAPACITOR SELECTION

For minimum output voltage ripple, the output capacitor C_{OUT} should be a ceramic, surface-mount type. Tantalum capacitors generally have a higher Effective Series Resistance (ESR) and may contribute to higher output voltage ripple. Leaded capacitors also increase ripple due to the higher inductance of the package itself. To achieve best operation with low input voltage and high load current, the input and pump capacitors (C_{IN} and C_{PUMP} , respectively) should also be surface-mount ceramic types. In all cases, X7R or X5R dielectric are recommended. See the typical operating circuit shown in Figure 3 for component values.

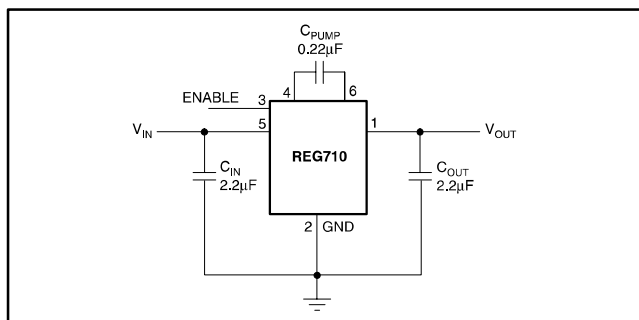

FIGURE 3: Typical Operating Circuit.

With light loads or higher input voltage, a smaller 0.1µF pump capacitor (C_{PUMP}) and smaller 1µF input and output capacitors (C_{IN} and C_{OUT} , respectively) can be used. To minimize output voltage ripple, increase the output capacitor, C_{OUT} , to 10µF or larger.

The capacitors listed in Table I can be used with the REG710. This is only a representative list of those parts that are compatible.

EFFICIENCY

The efficiency of the charge pump regulator varies with the output voltage version, the applied input voltage, the load current, and the internal operation mode of the device.

The approximate efficiency is given by:

$$\text{Efficiency (\%)} = \frac{V_{OUT}}{2 \cdot V_{IN}} \cdot 100$$

(step-up operating mode)

MANUFACTURER	PART NUMBER	VALUE	TOLERANCE	DIELECTRIC MATERIAL	PACKAGE SIZE	RATED WORKING VOLTAGE
Kemet	C1206C255K8RAC	2.2µF	±10%	X7R	1206	10V
	C1206C224K8RAC	0.22µF	±10%	X7R	1206	10V
Panasonic	ECJ-2YBOJ225K	2.2µF	±10%	X5R	805	6.3V
	ECJ-2VBIC224K	0.22µF	±10%	X7R	805	16V
	ECJ-2VBIC104	0.1µF	±10%	X7R	805	16V
Taiyo Yuden	EMK316BJ225KL	2.2µF	±10%	X7R	1206	16V
	TKM316BJ224KF	0.22µF	±10%	X7R	1206	25V

TABLE I: Suggested Capacitors.

$$\text{OR}$$

$$\frac{V_{OUT}}{V_{IN}} \cdot 100$$

(step-down operating mode)

Table II lists the approximate values of the input voltage at which the device changes internal operating mode.

See efficiency curves in the Typical Characteristics section for various loads and input voltages.

PRODUCT	OPERATING MODE CHANGES AT V_{IN} OF
REG710-2.5	> 3.2V
REG710-2.7	> 3.4V
REG710-3	> 3.7V
REG710-3.3	> 4.0V
REG710-5	Step-Up Only

TABLE II: Operating Mode Change versus V_{IN} .

LAYOUT

Large transient currents flow in the V_{IN} , V_{OUT} , and GND traces. To minimize both input and output ripple, keep the capacitors as close as possible to the regulator using short, direct circuit traces.

A suggested PCB routing is shown in Figure 4. The trace lengths from the input and output capacitors have been kept as short as possible.

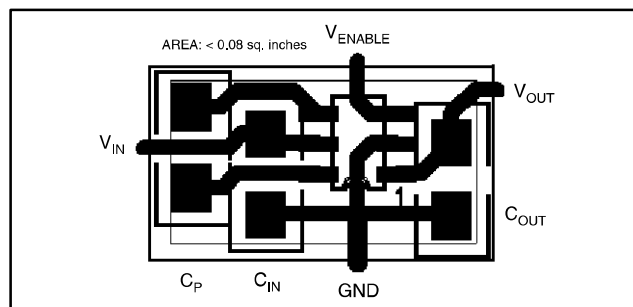

FIGURE 4: Suggested PCB Design for Minimum Ripple.

APPLICATION CIRCUITS

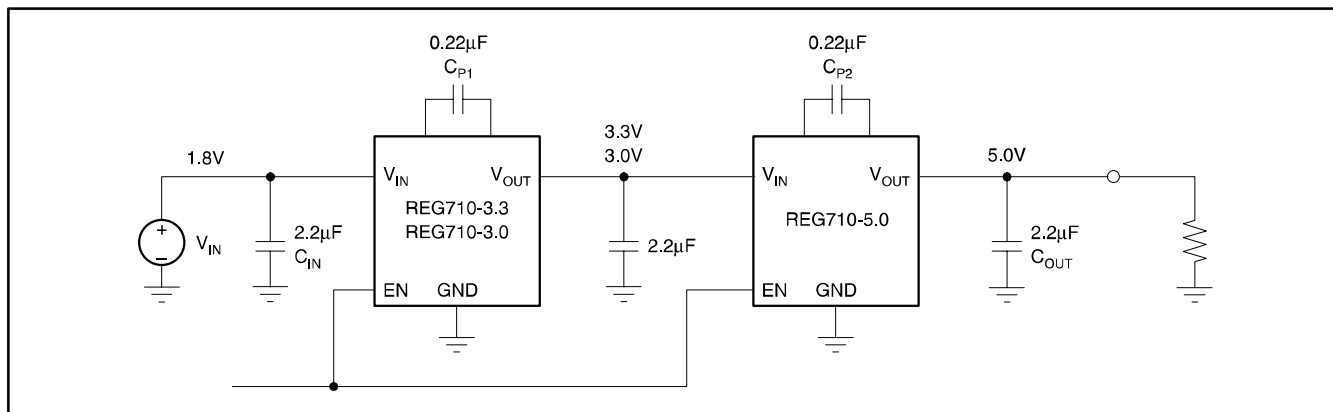

FIGURE 5: REG710 Circuit for Step-Up Operation from 1.8V to 5.0V with 10mA Output Current.

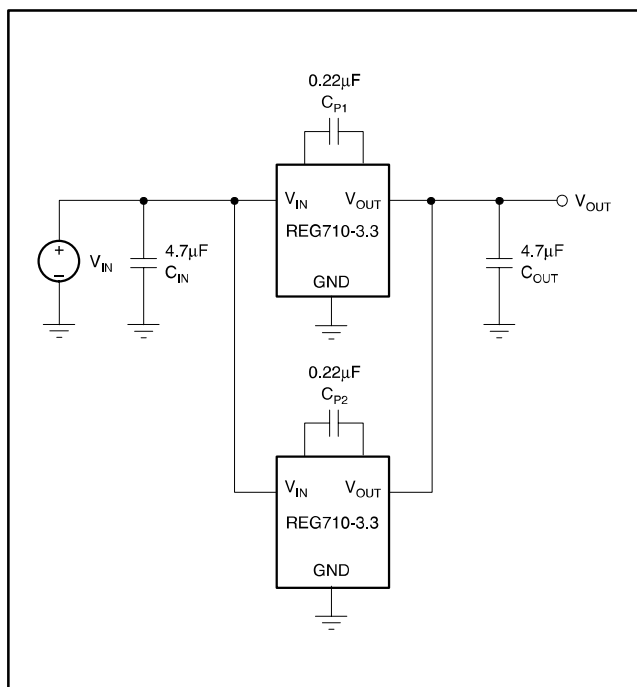

FIGURE 6: REG710 Circuit for Doubling the Output Current.

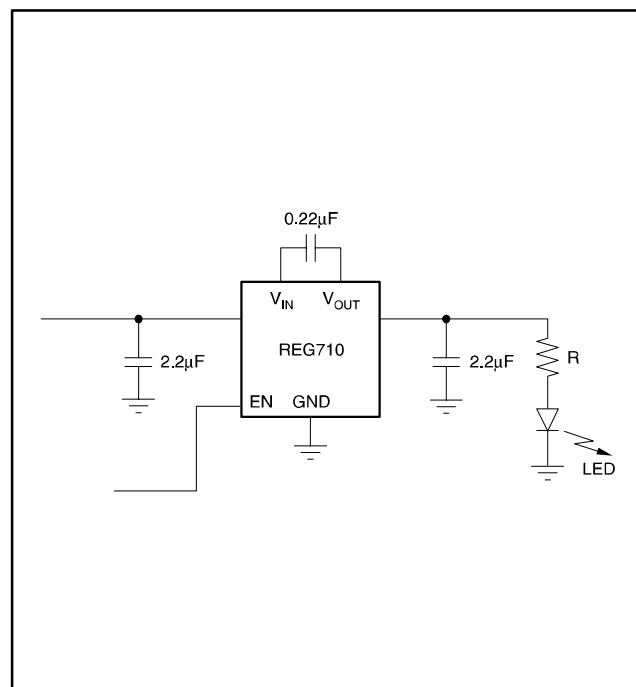

FIGURE 7: REG710 Circuit for Driving LEDs.

REG710

SBAS221C – DECEMBER 2001 – REVISED JULY 2002

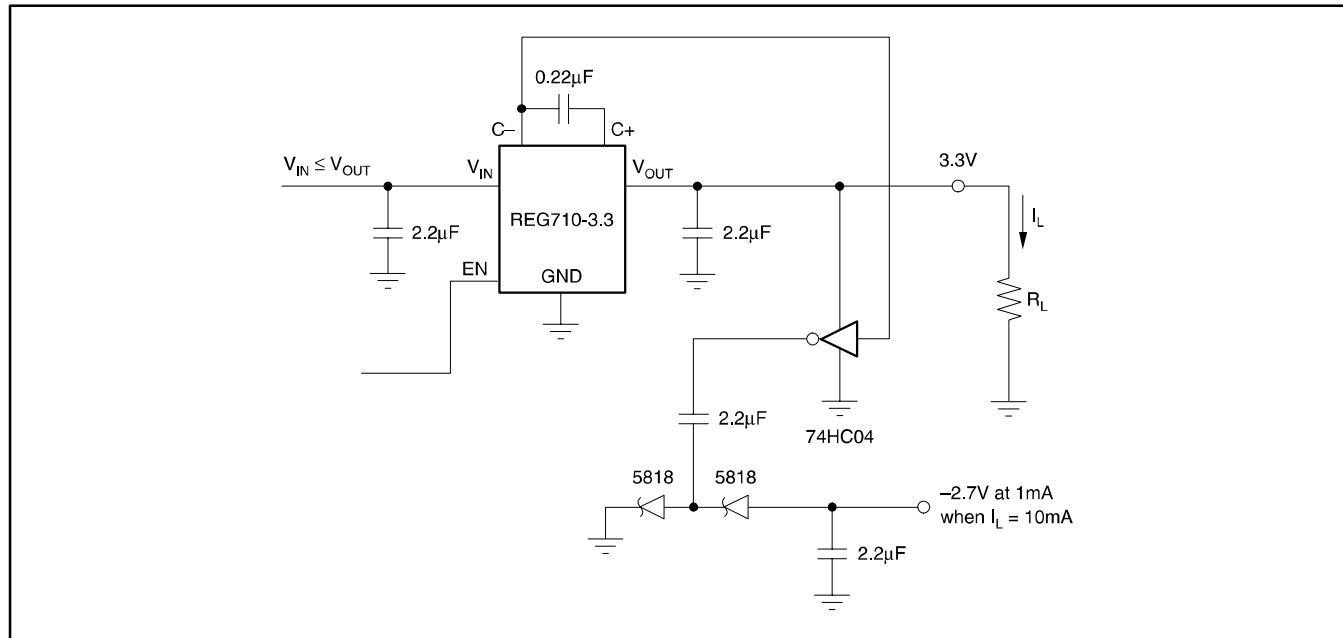

FIGURE 8: REG710 with Negative Bias Supply.

IMPORTANT NOTICE

Texas Instruments Incorporated and its subsidiaries (TI) reserve the right to make corrections, modifications, enhancements, improvements, and other changes to its products and services at any time and to discontinue any product or service without notice. Customers should obtain the latest relevant information before placing orders and should verify that such information is current and complete. All products are sold subject to TI's terms and conditions of sale supplied at the time of order acknowledgment.

TI warrants performance of its hardware products to the specifications applicable at the time of sale in accordance with TI's standard warranty. Testing and other quality control techniques are used to the extent TI deems necessary to support this warranty. Except where mandated by government requirements, testing of all parameters of each product is not necessarily performed.

TI assumes no liability for applications assistance or customer product design. Customers are responsible for their products and applications using TI components. To minimize the risks associated with customer products and applications, customers should provide adequate design and operating safeguards.

TI does not warrant or represent that any license, either express or implied, is granted under any TI patent right, copyright, mask work right, or other TI intellectual property right relating to any combination, machine, or process in which TI products or services are used. Information published by TI regarding third-party products or services does not constitute a license from TI to use such products or services or a warranty or endorsement thereof. Use of such information may require a license from a third party under the patents or other intellectual property of the third party, or a license from TI under the patents or other intellectual property of TI.

Reproduction of information in TI data books or data sheets is permissible only if reproduction is without alteration and is accompanied by all associated warranties, conditions, limitations, and notices. Reproduction of this information with alteration is an unfair and deceptive business practice. TI is not responsible or liable for such altered documentation.

Resale of TI products or services with statements different from or beyond the parameters stated by TI for that product or service voids all express and any implied warranties for the associated TI product or service and is an unfair and deceptive business practice. TI is not responsible or liable for any such statements.

Mailing Address:

Texas Instruments
Post Office Box 655303
Dallas, Texas 75265