

## QML CLASS V PRECISION TIMER

Check for Samples: [SE555-SP](#)

### FEATURES

- Timing From Microseconds to Hours
- Astable or Monostable Operation
- Adjustable Duty Cycle
- TTL-Compatible Output Can Sink or Source up to 100 mA
- QML-V Qualified, SMD 5962-98555
- Military Temperature Range (-55°C to 125°C)
- Rad-Tolerant: 25 kRad (Si) TID <sup>(1)</sup>

(1) Radiation tolerance is a typical value based upon initial device qualification with dose rate = 10 mrad/sec. Radiation Lot Acceptance Testing is available - contact factory for details.

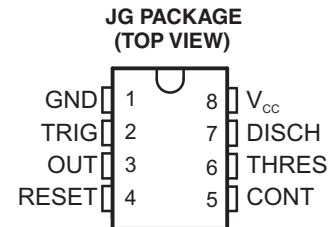

### DESCRIPTION/ORDERING INFORMATION

The SE555 is a precision timing circuit capable of producing accurate time delays or oscillation. In the time-delay or monostable mode of operation, the timed interval is controlled by a single external resistor and capacitor network. In the astable mode of operation, the frequency and duty cycle can be controlled independently with two external resistors and a single external capacitor.

The threshold and trigger levels normally are two-thirds and one-third, respectively, of V<sub>CC</sub>. These levels can be altered by use of the control-voltage terminal. When the trigger input falls below the trigger level, the flip-flop is set, and the output goes high. If the trigger input is above the trigger level and the threshold input is above the threshold level, the flip-flop is reset and the output is low. The reset (RESET) input can override all other inputs and can be used to initiate a new timing cycle. When RESET goes low, the flip-flop is reset, and the output goes low. When the output is low, a low-impedance path is provided between discharge (DISCH) and ground.

The output circuit is capable of sinking or sourcing current up to 100 mA. Operation is specified for supplies of 4.5 V to 16.5 V. With a 5-V supply, output levels are compatible with TTL inputs.



Please be aware that an important notice concerning availability, standard warranty, and use in critical applications of Texas Instruments semiconductor products and disclaimers thereto appears at the end of this data sheet.

**ORDERING INFORMATION<sup>(1)</sup>**

$T_A$	PACKAGE <sup>(2)</sup>		ORDERABLE PART NUMBER	TOP-SIDE MARKING
-55°C to 125°C	CDIP - JG	Tube of 50	5962-9855501VPA	5962-9855501VPA

- (1) For the most current package and ordering information, see the Package Option Addendum at the end of this document, or see the TI web site at [www.ti.com](http://www.ti.com).
- (2) Package drawings, thermal data, and symbolization are available at [www.ti.com/packaging](http://www.ti.com/packaging).

**Table 1. FUNCTION TABLE**

RESET	TRIGGER VOLTAGE <sup>(1)</sup>	THRESHOLD VOLTAGE <sup>(1)</sup>	OUTPUT	DISCHARGE SWITCH
Low	Irrelevant	Irrelevant	Low	On
High	<1/3 $V_{CC}$	Irrelevant	High	Off
High	>1/3 $V_{CC}$	>2/3 $V_{CC}$	Low	On
High	>1/3 $V_{CC}$	<2/3 $V_{CC}$	As previously established	

- (1) Voltage levels shown are nominal.

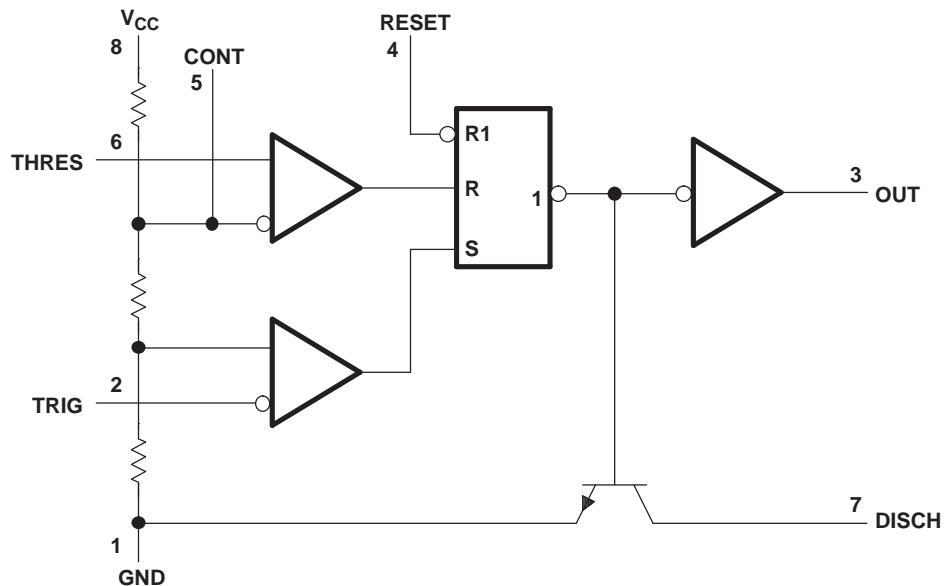
**FUNCTIONAL BLOCK DIAGRAM**

- A. RESET can override TRIG, which can override THRES.

## Absolute Maximum Ratings<sup>(1)</sup>

over operating free-air temperature range (unless otherwise noted)

			MIN	MAX	UNIT
$V_{CC}$	Supply voltage <sup>(2)</sup>			18	V
$V_I$	Input voltage	CONT, RESET, THRES, TRIG		$V_{CC}$	V
$I_O$	Output current			$\pm 200$	mA
$\theta_{JC}$	Package thermal impedance <sup>(3)</sup> (4)			45	°C/W
$T_J$	Operating virtual junction temperature			150	°C
	Lead temperature 1, 6 mm (1/16 in) from case for 60 s			300	°C
$T_{stg}$	Storage temperature range		-65	150	°C

- (1) Stresses beyond those listed under "absolute maximum ratings" may cause permanent damage to the device. These are stress ratings only, and functional operation of the device at these or any other conditions beyond those indicated under "recommended operating conditions" is not implied. Exposure to absolute-maximum-rated conditions for extended periods may affect device reliability.
- (2) All voltage values are with respect to GND.
- (3) Maximum power dissipation is a function of  $T_J(\max)$ ,  $\theta_{JC}$ , and  $T_C$ . The maximum allowable power dissipation at any allowable case temperature is  $P_D = (T_J(\max) - T_C)/\theta_{JC}$ . Operating at the absolute maximum  $T_J$  of 150°C can affect reliability.
- (4) The package thermal impedance is calculated in accordance with MIL-STD-883.

## Recommended Operating Conditions

over operating free-air temperature range (unless otherwise noted)

			MIN	MAX	UNIT
$V_{CC}$	Supply voltage		4.5	16.5	V
$V_I$	Input voltage	CONT, RESET, THRES, and TRIG		$V_{CC}$	V
$I_O$	Output current			$\pm 100$	mA
$T_A$	Operating free-air temperature		-55	125	°C

## ELECTRICAL CHARACTERISTICS

 $V_{CC} = 4.5\text{ V to }16.5\text{ V}$ , over operating free-air temperature range (unless otherwise noted)

PARAMETER		TEST CONDITIONS		MIN	TYP	MAX	UNIT
$I_{CC}$	Power supply current	$V_{CC} = 4.5\text{ V}$ , $R_L = \infty$	$T_A = 25^\circ\text{C}, 125^\circ\text{C}, -55^\circ\text{C}$			5	mA
		$V_{CC} = 16.5\text{ V}$ , $R_L = \infty$	$T_A = 25^\circ\text{C}, 125^\circ\text{C}, -55^\circ\text{C}$			20	
$V_{TR}$	Trigger voltage	$V_{CC} = 4.5\text{ V}$	$T_A = 25^\circ\text{C}$	1.30		1.80	V
			$T_A = 125^\circ\text{C}$	1.30		2.10	
			$T_A = -55^\circ\text{C}$	1.15		1.80	
		$V_{CC} = 16.5\text{ V}$	$T_A = 25^\circ\text{C}$	5.20		5.80	
			$T_A = 125^\circ\text{C}$	5.20		6.10	
			$T_A = -55^\circ\text{C}$	5		5.80	
$I_{TR}$	Trigger current	$V_{CC} = 16.5\text{ V}$ for $V_{TR} = 5\text{ V}$	$T_A = 25^\circ\text{C}, 125^\circ\text{C}, -55^\circ\text{C}$	-5			$\mu\text{A}$
$V_{TH}$	Threshold voltage	$V_{CC} = 4.5\text{ V}$	$T_A = 25^\circ\text{C}$	2.70		3.30	V
			$T_A = 125^\circ\text{C}, -55^\circ\text{C}$	2.60		3.40	
		$V_{CC} = 16.5\text{ V}$	$T_A = 25^\circ\text{C}$	10.70		11.30	
			$T_A = 125^\circ\text{C}, -55^\circ\text{C}$	10.60		11.40	
$I_{TH}$	Threshold current	$V_{CC} = 16.5\text{ V}$	$T_A = 25^\circ\text{C}, 125^\circ\text{C}$			250	nA
			$T_A = -55^\circ\text{C}$			2.5	$\mu\text{A}$

**ELECTRICAL CHARACTERISTICS (continued)**
 $V_{CC} = 4.5\text{ V to }16.5\text{ V}$ , over operating free-air temperature range (unless otherwise noted)

PARAMETER		TEST CONDITIONS		MIN	TYP	MAX	UNIT
$V_{OL}$	Low level output voltage	$V_{CC} = 4.5\text{ V}$ , $I_{SINK} = 5\text{ mA}$	$T_A = 25^\circ\text{C}$			0.25	V
			$T_A = 125^\circ\text{C}, -55^\circ\text{C}$			0.35	
		$V_{CC} = 4.5\text{ V}$ , $I_{SINK} = 50\text{ mA}$	$T_A = 25^\circ\text{C}, 125^\circ\text{C}$			2.20	
			$T_A = -55^\circ\text{C}$			2.60	
		$V_{CC} = 16.5\text{ V}$ , $I_{SINK} = 10\text{ mA}$	$T_A = 25^\circ\text{C}, -55^\circ\text{C}$			0.15	
			$T_A = 125^\circ\text{C}$			0.25	
		$V_{CC} = 16.5\text{ V}$ , $I_{SINK} = 50\text{ mA}$	$T_A = 25^\circ\text{C}, -55^\circ\text{C}$			0.50	
			$T_A = 125^\circ\text{C}$			0.70	
		$V_{CC} = 16.5\text{ V}$ , $I_{SINK} = 100\text{ mA}$	$T_A = 25^\circ\text{C}$			2.20	
			$T_A = 125^\circ\text{C}, -55^\circ\text{C}$			2.80	
$V_{OH}$	High level output voltage	$V_{CC} = 4.5\text{ V}$ , $I_{SOURCE} = -100\text{ mA}$	$T_A = 25^\circ\text{C}, 125^\circ\text{C}$	2.60			V
			$T_A = -55^\circ\text{C}$		2.20		
		$V_{CC} = 16.5\text{ V}$ , $I_{SOURCE} = -100\text{ mA}$	$T_A = 25^\circ\text{C}, 125^\circ\text{C}$	14.60			
			$T_A = -55^\circ\text{C}$		14		
$I_{CEX}$	Discharge transistor leakage current	$V_{CC} = 16.5\text{ V}$	$T_A = 25^\circ\text{C}, -55^\circ\text{C}$			100	nA
			$T_A = 125^\circ\text{C}$			3	$\mu\text{A}$
$V_{SAT}$	Discharge transistor saturation voltage	$V_{CC} = 16.5\text{ V}$ , $I_D = 50\text{ mA}$	$T_A = 25^\circ\text{C}, -55^\circ\text{C}$			0.80	V
			$T_A = 125^\circ\text{C}$			1	
$V_R$	Reset voltage	$V_{CC} = 16.5\text{ V}$	$T_A = 25^\circ\text{C}, 125^\circ\text{C}, -55^\circ\text{C}$	0.10		1.30	V
$I_R$	Reset current	$V_{CC} = 16.5\text{ V}, V_R = 0\text{ V}$	$T_A = 25^\circ\text{C}, 125^\circ\text{C}, -55^\circ\text{C}$	-1.60		0	mA
$t_{PLH}$	Propagation delay time, low to high level output (monostable)	$4.5\text{ V} \leq V_{CC} \leq 16.5\text{ V}$ , $R_T = 1\text{ k}\Omega, C_T = 0.1\text{ }\mu\text{F}$	$T_A = 25^\circ\text{C}, -55^\circ\text{C}$			800	ns
			$T_A = 125^\circ\text{C}$			900	
$t_{TLH}$	Transition time, low to high level output (monostable)	$4.5\text{ V} \leq V_{CC} \leq 16.5\text{ V}$ , $R_T = 1\text{ k}\Omega, C_T = 0.1\text{ }\mu\text{F}$	$T_A = 25^\circ\text{C}, 125^\circ\text{C}, -55^\circ\text{C}$			300	ns
$t_{THL}$	Transition time, high to low level output (monostable)	$4.5\text{ V} \leq V_{CC} \leq 16.5\text{ V}$ , $R_T = 1\text{ k}\Omega, C_T = 0.1\text{ }\mu\text{F}$	$T_A = 25^\circ\text{C}, 125^\circ\text{C}, -55^\circ\text{C}$			300	ns
$t_{D(OH)}$	Time delay, output high (monostable)	$4.5\text{ V} \leq V_{CC} \leq 16.5\text{ V}$ , $R_T = 1\text{ k}\Omega, C_T = 0.1\text{ }\mu\text{F}$	$T_A = 25^\circ\text{C}, 125^\circ\text{C}, -55^\circ\text{C}$		106.70	113.30	$\mu\text{s}$
					10.67	11.33	ms
$\Delta t_{D(OH)} / \Delta V_{CC}$	Drift in time delay versus change in supply voltage (monostable)	$\Delta V_{CC} = 12\text{ V}$ , $R_T = 1\text{ k}\Omega, C_T = 0.1\text{ }\mu\text{F}$	$T_A = 25^\circ\text{C}$	-220		220	ns/V
$t_{PHL}$	Propagation delay time, threshold to output	$4.5\text{ V} \leq V_{CC} \leq 16.5\text{ V}$ , $R_T = 1\text{ k}\Omega$	$T_A = 25^\circ\text{C}, 125^\circ\text{C}, -55^\circ\text{C}$			12	$\mu\text{s}$
$\Delta t_{D(OH)} / \Delta T$	Temperature coefficient of time delay (monostable)	$V_{CC} = 16.5\text{ V}$ , $R_T = 1\text{ k}\Omega, C_T = 0.1\text{ }\mu\text{F}$	$T_A = 125^\circ\text{C}, -55^\circ\text{C}$	-11		11	ns/ $^\circ\text{C}$
$t_{ch}$	Capacitor charge time (astable)	$4.5\text{ V} \leq V_{CC} \leq 16.5\text{ V}$ , $R_{TA} = R_{TB} = 1\text{ k}\Omega$ , $C_T = 0.1\text{ }\mu\text{F}$	$T_A = 25^\circ\text{C}, 125^\circ\text{C}, -55^\circ\text{C}$		120	156	$\mu\text{s}$
					11.30	15	ms
$t_{dis}$	Capacitor discharge time (astable)	$4.5\text{ V} \leq V_{CC} \leq 16.5\text{ V}$ , $R_{TA} = R_{TB} = 1\text{ k}\Omega$ , $C_T = 0.1\text{ }\mu\text{F}$	$T_A = 25^\circ\text{C}, 125^\circ\text{C}, -55^\circ\text{C}$		57.50	80	$\mu\text{s}$
					5.40	7.70	ms

**ELECTRICAL CHARACTERISTICS (continued)**

V<sub>CC</sub> = 4.5 V to 16.5 V, over operating free-air temperature range (unless otherwise noted)

PARAMETER		TEST CONDITIONS		MIN	TYP	MAX	UNIT
$\Delta t_{ch} / \Delta V_{CC}$	Drift in capacitor charge time versus change in supply voltage (astable)	$\Delta V_{CC} = 12\text{ V}$ , $R_{TA} = R_{TB} = 1\text{ k}\Omega$ , $C_T = 0.1\text{ }\mu\text{F}$	$T_A = 25^\circ\text{C}$	-820		820	ns/V
$\Delta t_{ch} / \Delta T$	Temperature coefficient of capacitor charge time (astable)	$\Delta V_{CC} = 16.5\text{ V}$ , $R_{TA} = R_{TB} = 1\text{ k}\Omega$ , $C_T = 0.1\text{ }\mu\text{F}$	$T_A = 125^\circ\text{C}, -55^\circ\text{C}$	-68		68	ns/°C
$t_{res}$	Reset time	$V_{CC} = 16.5\text{ V}$	$T_A = 25^\circ\text{C}, -55^\circ\text{C}$			1.50	$\mu\text{s}$
			$T_A = 125^\circ\text{C}$			2	

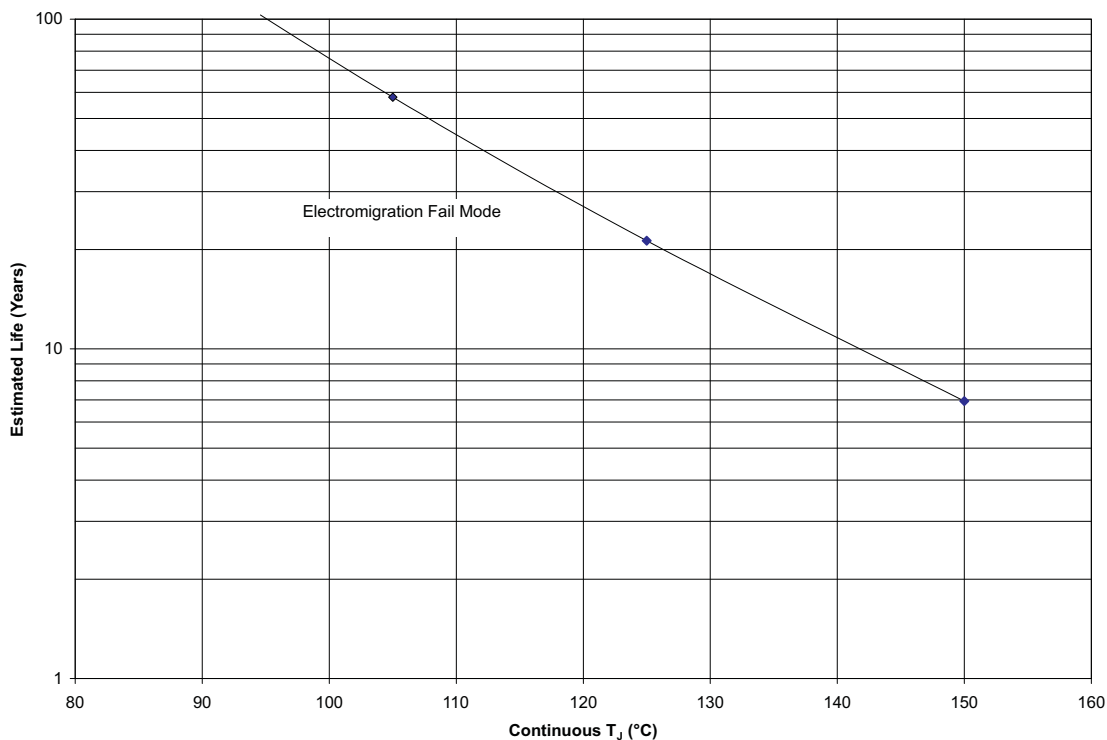

- A. See datasheet for absolute maximum and minimum recommended operating conditions.
- B. Silicon operating life design goal is 10 years at 105°C junction temperature (does not include package interconnect life).

**Figure 1. SE555 8/JG Package Operating Life Derating Chart**

TYPICAL CHARACTERISTICS

LOW-LEVEL OUTPUT VOLTAGE  
vs  
LOW-LEVEL OUTPUT CURRENT

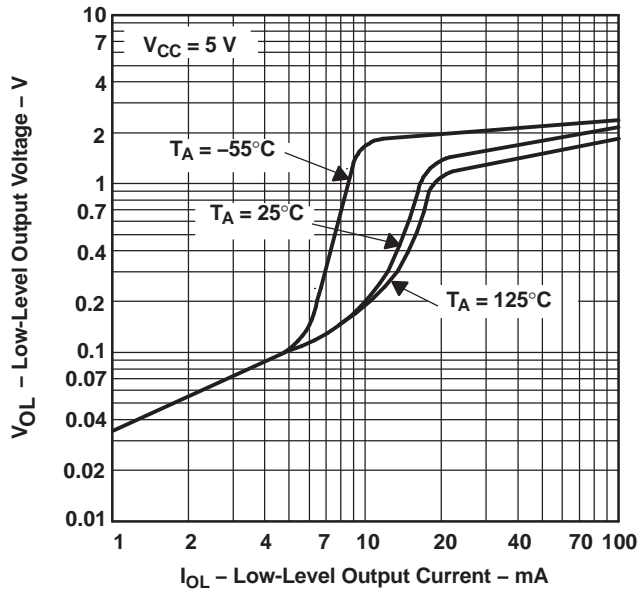

Figure 2.

LOW-LEVEL OUTPUT VOLTAGE  
vs  
LOW-LEVEL OUTPUT CURRENT

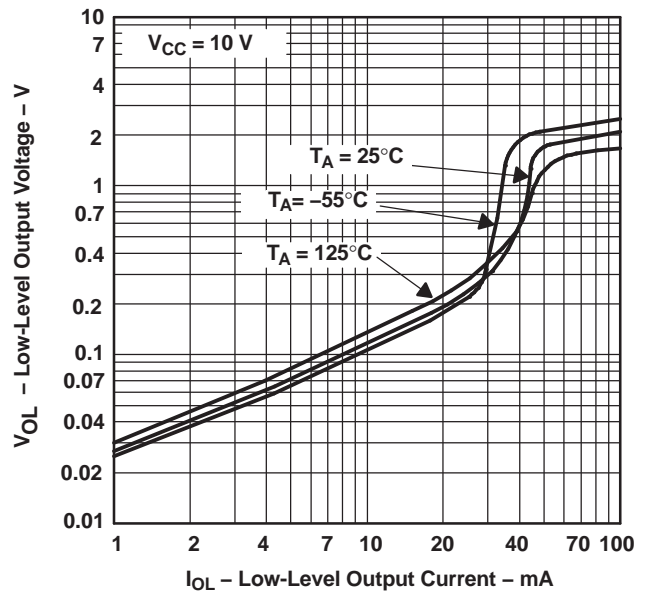

Figure 3.

LOW-LEVEL OUTPUT VOLTAGE  
vs  
LOW-LEVEL OUTPUT CURRENT

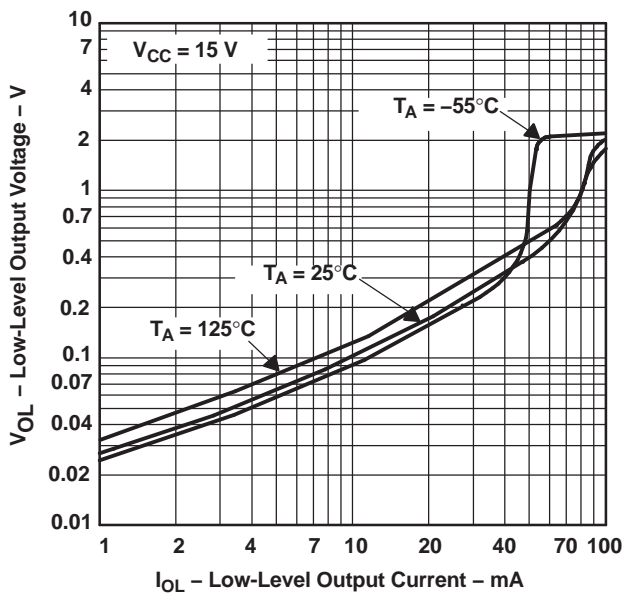

Figure 4.

DROP BETWEEN SUPPLY VOLTAGE AND OUTPUT  
vs  
HIGH-LEVEL OUTPUT CURRENT

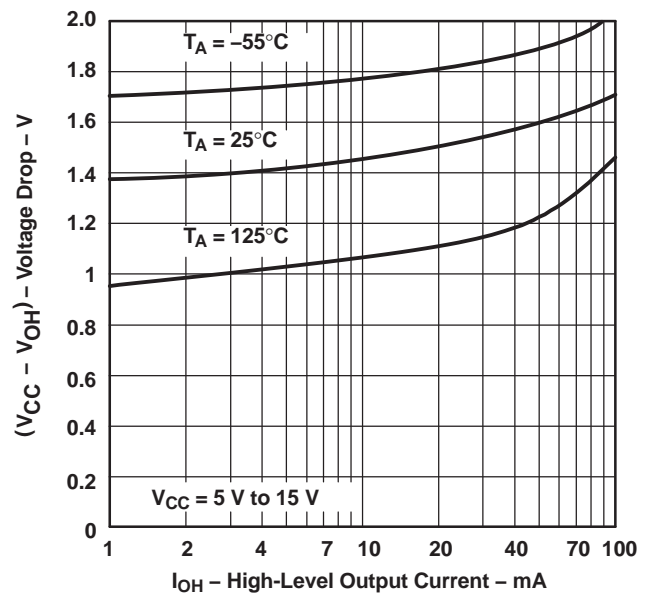

Figure 5.

TYPICAL CHARACTERISTICS (continued)

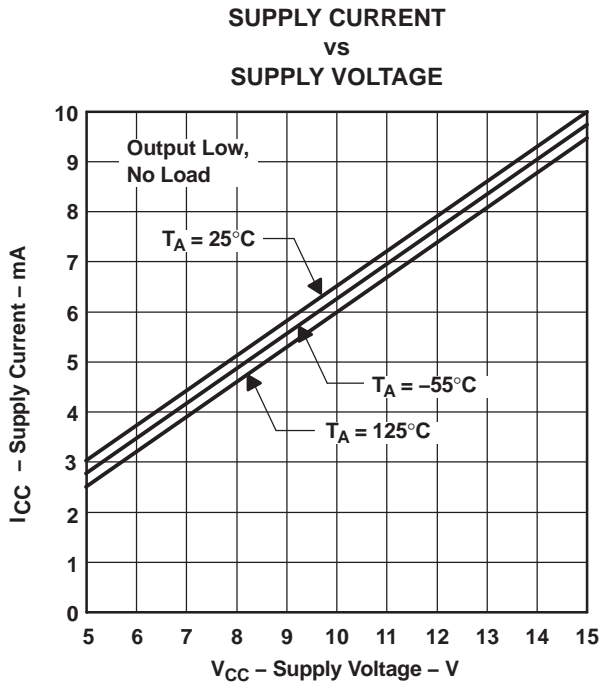

Figure 6.

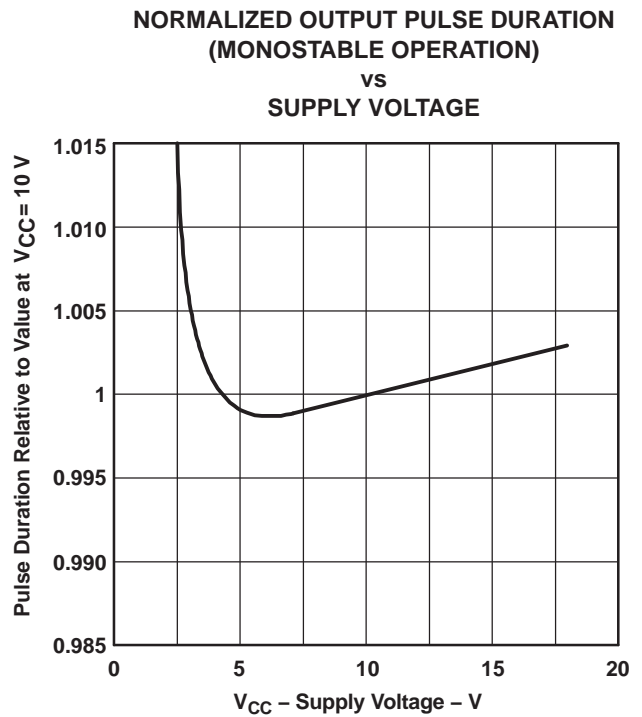

Figure 7.

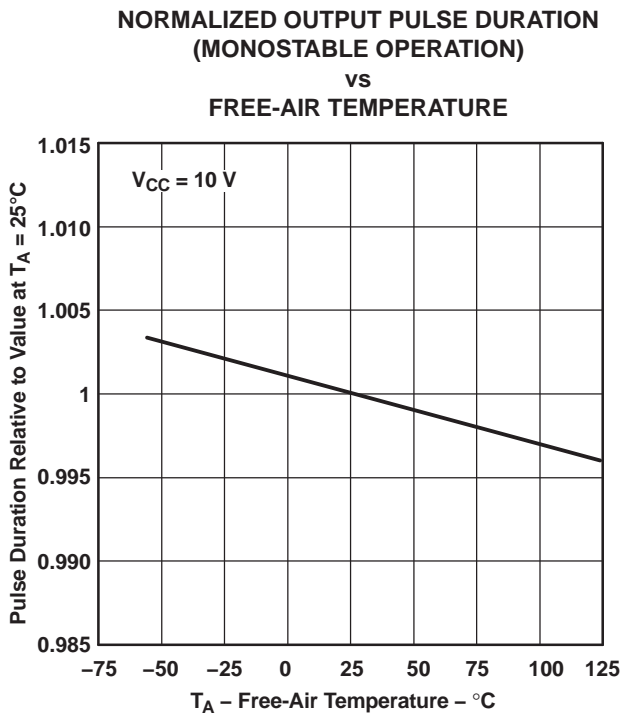

Figure 8.

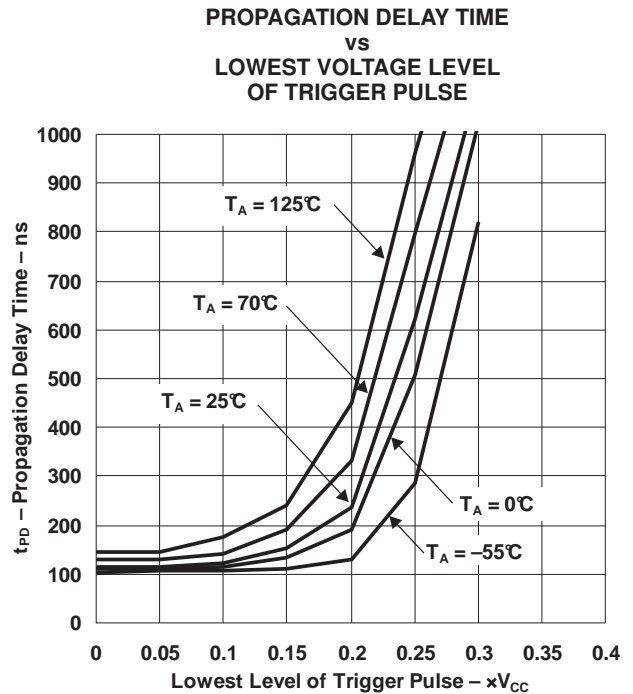
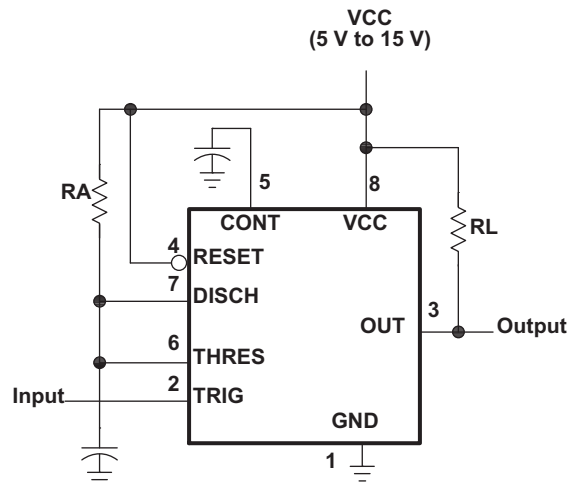

Figure 9.

## APPLICATION INFORMATION

### Monostable Operation

For monostable operation, any of these timers can be connected as shown in Figure 10. If the output is low, application of a negative-going pulse to the trigger (TRIG) sets the flip-flop ( $\bar{Q}$  goes low), drives the output high, and turns off Q1. Capacitor C then is charged through  $R_A$  until the voltage across the capacitor reaches the threshold voltage of the threshold (THRES) input. If TRIG has returned to a high level, the output of the threshold comparator resets the flip-flop ( $\bar{Q}$  goes high), drives the output low, and discharges C through Q1.



**Figure 10. Circuit for Monostable Operation**

Monostable operation is initiated when TRIG voltage falls below the trigger threshold. Once initiated, the sequence ends only if TRIG is high at the end of the timing interval. Because of the threshold level and saturation voltage of Q1, the output pulse duration is approximately  $t_w = 1.1R_A C$ . Figure 12 is a plot of the time constant for various values of  $R_A$  and C. The threshold levels and charge rates both are directly proportional to the supply voltage,  $V_{CC}$ . The timing interval is, therefore, independent of the supply voltage, so long as the supply voltage is constant during the time interval.

Applying a negative-going trigger pulse simultaneously to RESET and TRIG during the timing interval discharges C and reinitiates the cycle, commencing on the positive edge of the reset pulse. The output is held low as long as the reset pulse is low. To prevent false triggering, when RESET is not used, it should be connected to  $V_{CC}$ .



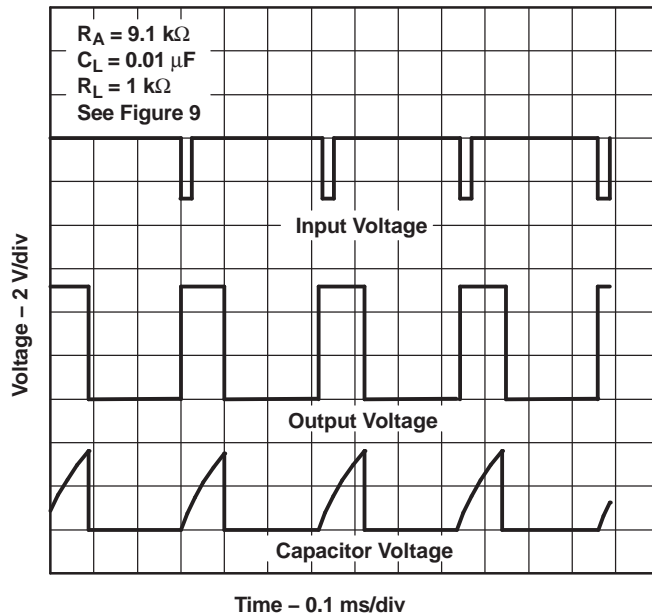

Figure 11. Typical Monostable Waveforms

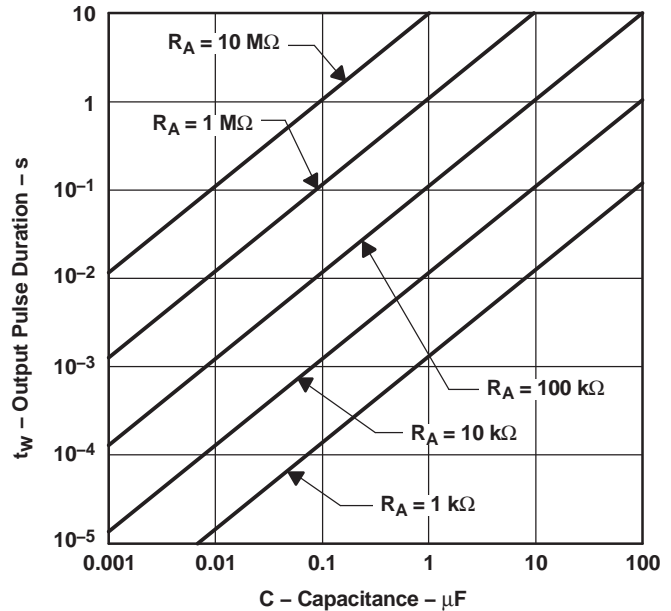
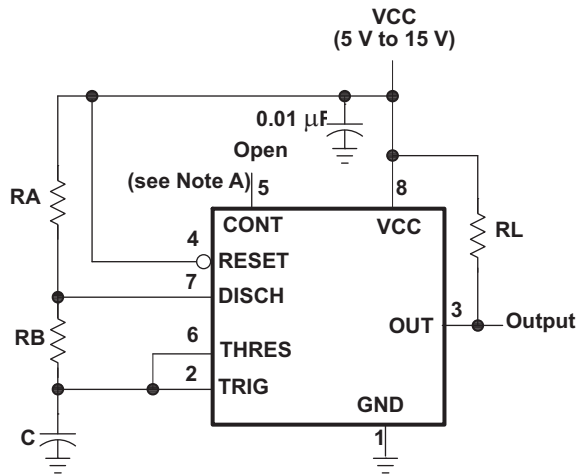

Figure 12. Output Pulse Duration vs Capacitance

### Astable Operation

As shown in Figure 13, adding a second resistor,  $R_B$ , to the circuit of Figure 10 and connecting the trigger input to the threshold input causes the timer to self-trigger and run as a multivibrator. The capacitor  $C$  charges through  $R_A$  and  $R_B$  and then discharges through  $R_B$  only. Therefore, the duty cycle is controlled by the values of  $R_A$  and  $R_B$ .

This astable connection results in capacitor  $C$  charging and discharging between the threshold-voltage level ( $X0.67 \times V_{CC}$ ) and the trigger-voltage level ( $X0.33 \times V_{CC}$ ). As in the monostable circuit, charge and discharge times (and, therefore, the frequency and duty cycle) are independent of the supply voltage.



NOTE A: Decoupling CONT voltage to ground with a capacitor can improve operation. This should be evaluated for individual applications.

Figure 13. Circuit for Astable Operation

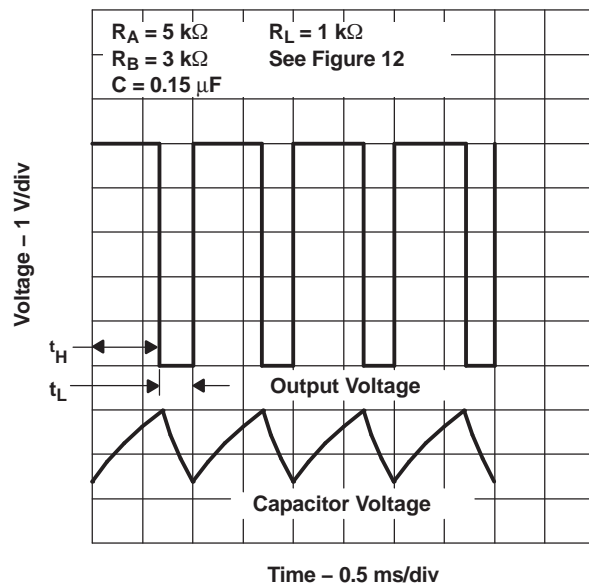

Figure 14. Typical Astable Waveforms

Figure 13 shows typical waveforms generated during astable operation. The output high-level duration  $t_H$  and low-level duration  $t_L$  can be calculated as follows:

$$t_H = 0.693 (R_A + R_B) C \quad (1)$$

$$t_L = 0.693 (R_B) C \quad (2)$$

Other useful relationships are shown in the following equations.

$$\text{period} = t_H + t_L = 0.693 (R_A + 2R_B) C \quad (3)$$

$$\text{frequency} \approx \frac{1.44}{(R_A + 2R_B) C} \quad (4)$$

$$\text{Output driver duty cycle} = \frac{t_L}{t_H + t_L} = \frac{R_B}{R_A + 2R_B} \quad (5)$$

$$\text{Output waveform duty cycle} = \frac{t_H}{t_H + t_L} = 1 - \frac{R_B}{R_A + 2R_B} \quad (6)$$

$$\text{Low-to-high ratio} = \frac{t_L}{t_H} = \frac{R_B}{R_A + R_B} \quad (7)$$

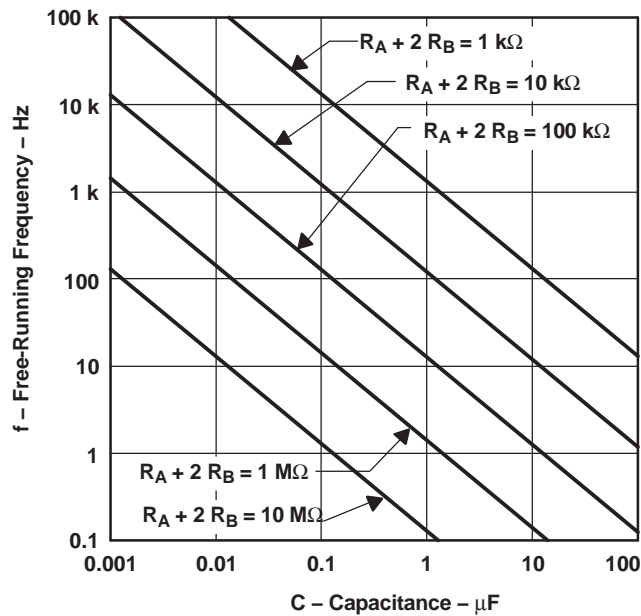

Figure 15. Free-Running Frequency

### Missing-Pulse Detector

The circuit shown in Figure 16 can be used to detect a missing pulse or abnormally long spacing between consecutive pulses in a train of pulses. The timing interval of the monostable circuit is retriggered continuously by the input pulse train as long as the pulse spacing is less than the timing interval. A longer pulse spacing, missing pulse, or terminated pulse train permits the timing interval to be completed, thereby generating an output pulse as shown in Figure 17.

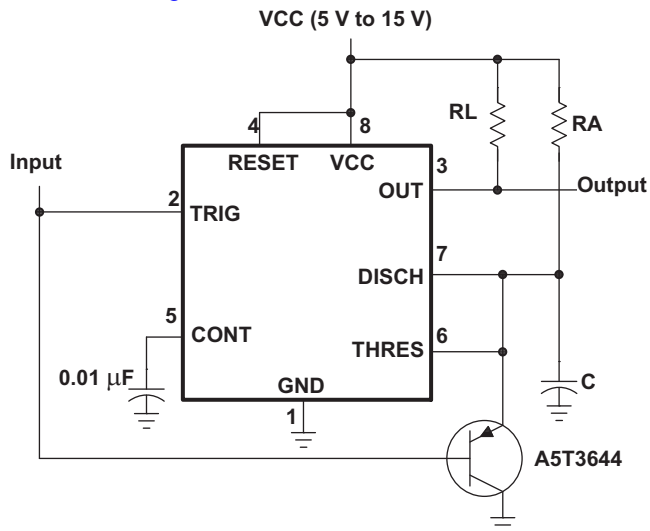

Figure 16. Circuit for Missing-Pulse Detector

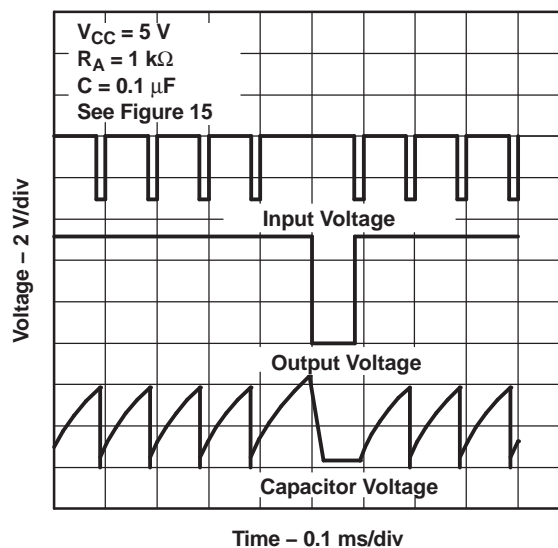

Figure 17. Completed Timing Waveforms for Missing-Pulse Detector

## Frequency Divider

By adjusting the length of the timing cycle, the basic circuit of [Figure 10](#) can be made to operate as a frequency divider. [Figure 18](#) shows a divide-by-three circuit that makes use of the fact that retriggering cannot occur during the timing cycle.

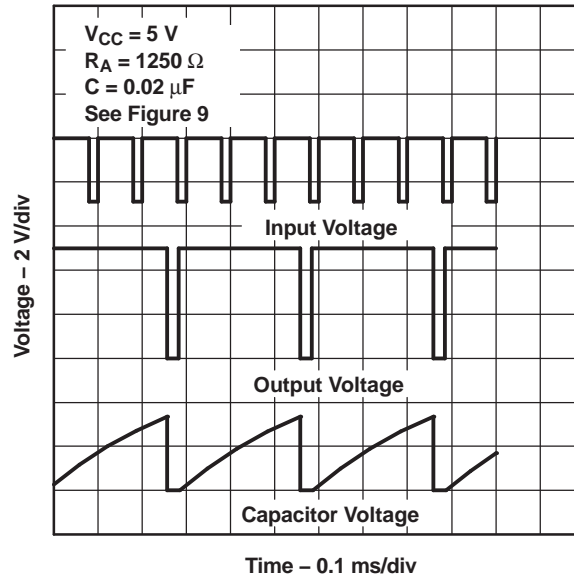
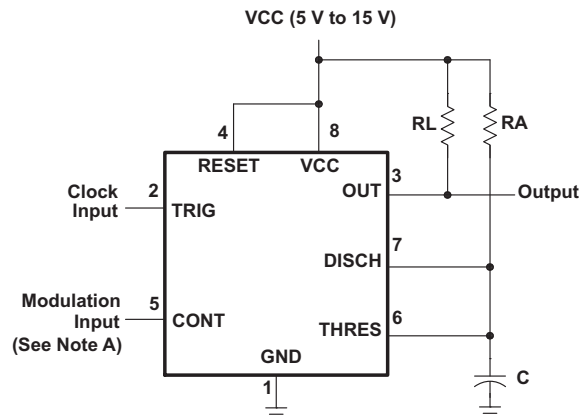

Figure 18. Divide-by-Three Circuit Waveforms

## Pulse-Width Modulation

The operation of the timer can be modified by modulating the internal threshold and trigger voltages, which is accomplished by applying an external voltage (or current) to CONT. Figure 19 shows a circuit for pulse-width modulation. A continuous input pulse train triggers the monostable circuit, and a control signal modulates the threshold voltage. Figure 20 shows the resulting output pulse-width modulation. While a sine-wave modulation signal is shown, any wave shape could be used.



NOTE A: The modulating signal can be direct or capacitively coupled to CONT. For direct coupling, the effects of modulation source voltage and impedance on the bias of the timer should be considered.

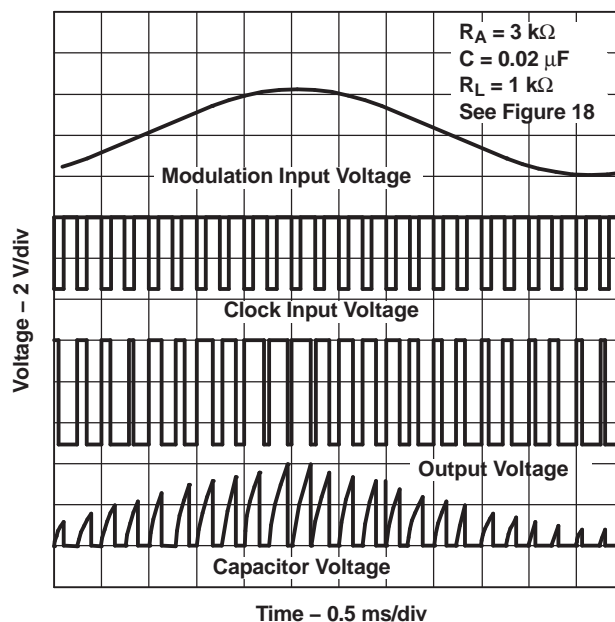
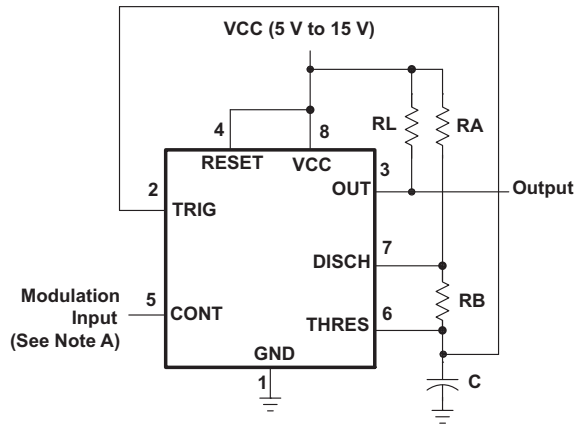

Figure 19. Circuit for Pulse-Width Modulation

Figure 20. Pulse-Width-Modulation Waveforms

## Pulse-Position Modulation

As shown in Figure 21, any of these timers can be used as a pulse-position modulator. This application modulates the threshold voltage and, thereby, the time delay, of a free-running oscillator. Figure 22 shows a triangular-wave modulation signal for such a circuit; however, any wave shape could be used.



NOTE A: The modulating signal can be direct or capacitively coupled to CONT. For direct coupling, the effects of modulation source voltage and impedance on the bias of the timer should be considered.

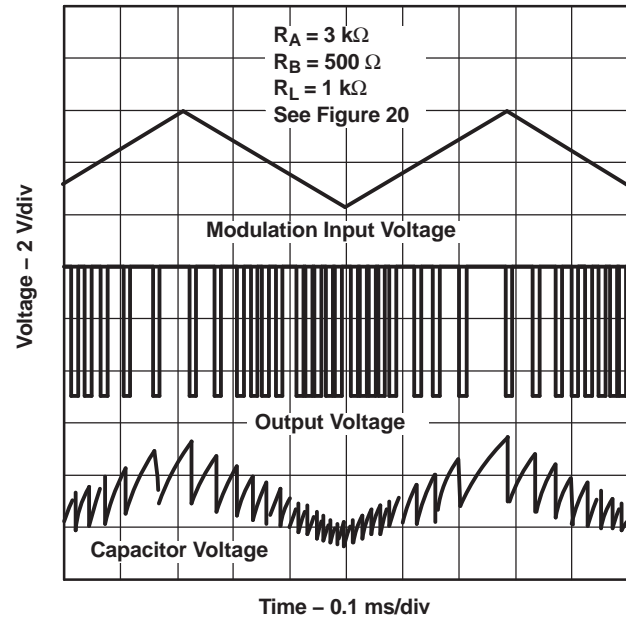
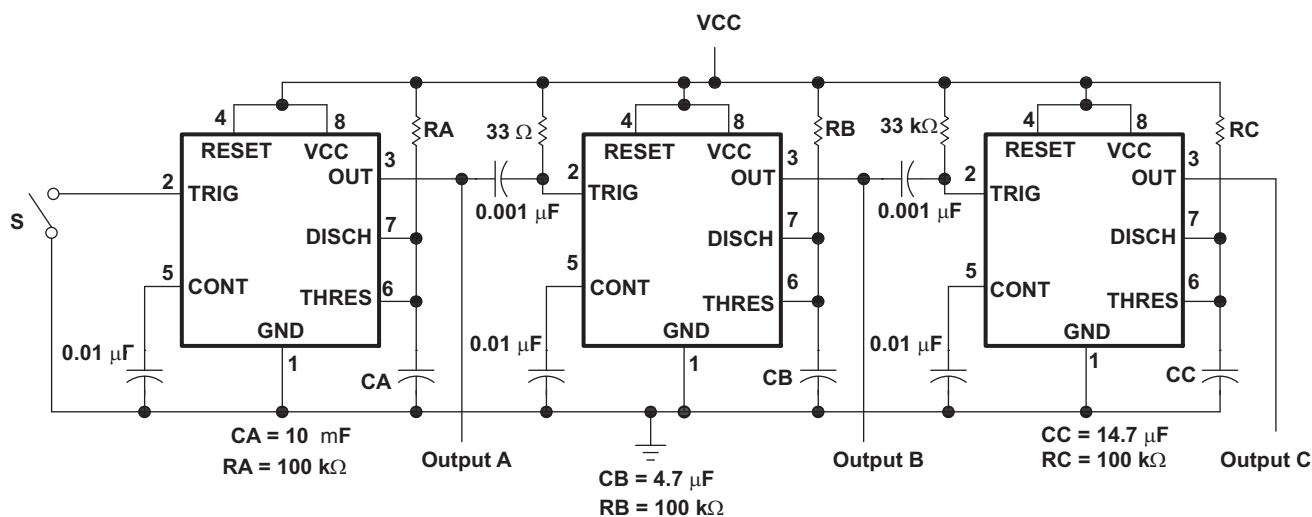

Figure 21. Circuit for Pulse-Position Modulation

Figure 22. Pulse-Position-Modulation Waveforms

### Sequential Timer

Many applications, such as computers, require signals for initializing conditions during start-up. Other applications, such as test equipment, require activation of test signals in sequence. These timing circuits can be connected to provide such sequential control. The timers can be used in various combinations of astable or monostable circuit connections, with or without modulation, for extremely flexible waveform control. Figure 23 shows a sequencer circuit with possible applications in many systems, and Figure 24 shows the output waveforms.



NOTE A: S closes momentarily at t = 0.

Figure 23. Sequential Timer Circuit

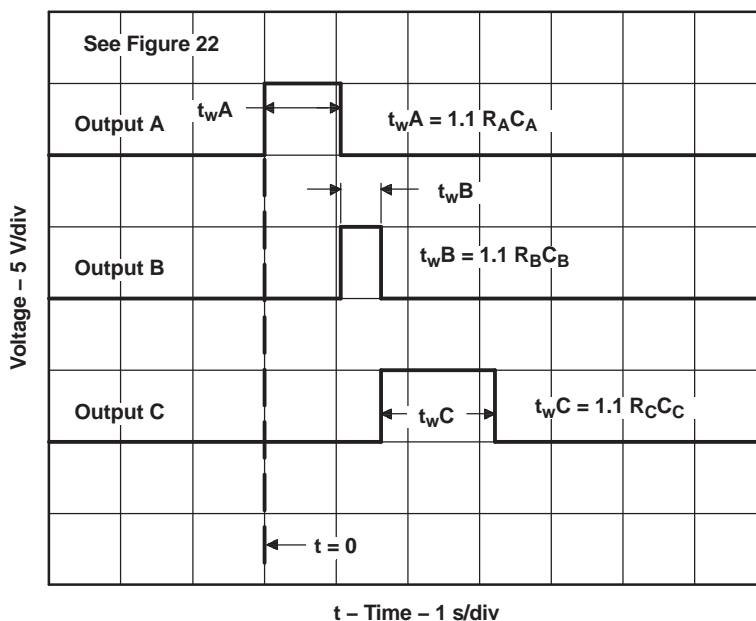

Figure 24. Sequential Timer Waveforms

**PACKAGING INFORMATION**

Orderable Device	Status (1)	Package Type	Package Drawing	Pins	Package Qty	Eco Plan (2)	Lead/Ball Finish	MSL Peak Temp (3)	Op Temp (°C)	Top-Side Markings (4)	Samples
5962-9855501VPA	ACTIVE	CDIP	JG	8	1	TBD	A42	N / A for Pkg Type	-55 to 125	5962-9855501VPA	<a href="#">Samples</a>

(1) The marketing status values are defined as follows:

**ACTIVE:** Product device recommended for new designs.

**LIFEBUY:** TI has announced that the device will be discontinued, and a lifetime-buy period is in effect.

**NRND:** Not recommended for new designs. Device is in production to support existing customers, but TI does not recommend using this part in a new design.

**PREVIEW:** Device has been announced but is not in production. Samples may or may not be available.

**OBSOLETE:** TI has discontinued the production of the device.

(2) Eco Plan - The planned eco-friendly classification: Pb-Free (RoHS), Pb-Free (RoHS Exempt), or Green (RoHS & no Sb/Br) - please check <http://www.ti.com/productcontent> for the latest availability information and additional product content details.

**TBD:** The Pb-Free/Green conversion plan has not been defined.

**Pb-Free (RoHS):** TI's terms "Lead-Free" or "Pb-Free" mean semiconductor products that are compatible with the current RoHS requirements for all 6 substances, including the requirement that lead not exceed 0.1% by weight in homogeneous materials. Where designed to be soldered at high temperatures, TI Pb-Free products are suitable for use in specified lead-free processes.

**Pb-Free (RoHS Exempt):** This component has a RoHS exemption for either 1) lead-based flip-chip solder bumps used between the die and package, or 2) lead-based die adhesive used between the die and leadframe. The component is otherwise considered Pb-Free (RoHS compatible) as defined above.

**Green (RoHS & no Sb/Br):** TI defines "Green" to mean Pb-Free (RoHS compatible), and free of Bromine (Br) and Antimony (Sb) based flame retardants (Br or Sb do not exceed 0.1% by weight in homogeneous material)

(3) MSL, Peak Temp. -- The Moisture Sensitivity Level rating according to the JEDEC industry standard classifications, and peak solder temperature.

(4) Multiple Top-Side Markings will be inside parentheses. Only one Top-Side Marking contained in parentheses and separated by a "~" will appear on a device. If a line is indented then it is a continuation of the previous line and the two combined represent the entire Top-Side Marking for that device.

**Important Information and Disclaimer:**The information provided on this page represents TI's knowledge and belief as of the date that it is provided. TI bases its knowledge and belief on information provided by third parties, and makes no representation or warranty as to the accuracy of such information. Efforts are underway to better integrate information from third parties. TI has taken and continues to take reasonable steps to provide representative and accurate information but may not have conducted destructive testing or chemical analysis on incoming materials and chemicals. TI and TI suppliers consider certain information to be proprietary, and thus CAS numbers and other limited information may not be available for release.

In no event shall TI's liability arising out of such information exceed the total purchase price of the TI part(s) at issue in this document sold by TI to Customer on an annual basis.

**OTHER QUALIFIED VERSIONS OF SE555-SP :**

- Catalog: [SE555](#)



- Military: [SE555M](#)

NOTE: Qualified Version Definitions:

- Catalog - TI's standard catalog product
- Military - QML certified for Military and Defense Applications

JG (R-GDIP-T8)

CERAMIC DUAL-IN-LINE



- NOTES: A. All linear dimensions are in inches (millimeters).  
 B. This drawing is subject to change without notice.  
 C. This package can be hermetically sealed with a ceramic lid using glass frit.  
 D. Index point is provided on cap for terminal identification.  
 E. Falls within MIL STD 1835 GDIP1-T8

## IMPORTANT NOTICE

Texas Instruments Incorporated and its subsidiaries (TI) reserve the right to make corrections, enhancements, improvements and other changes to its semiconductor products and services per JESD46, latest issue, and to discontinue any product or service per JESD48, latest issue. Buyers should obtain the latest relevant information before placing orders and should verify that such information is current and complete. All semiconductor products (also referred to herein as "components") are sold subject to TI's terms and conditions of sale supplied at the time of order acknowledgment.

TI warrants performance of its components to the specifications applicable at the time of sale, in accordance with the warranty in TI's terms and conditions of sale of semiconductor products. Testing and other quality control techniques are used to the extent TI deems necessary to support this warranty. Except where mandated by applicable law, testing of all parameters of each component is not necessarily performed.

TI assumes no liability for applications assistance or the design of Buyers' products. Buyers are responsible for their products and applications using TI components. To minimize the risks associated with Buyers' products and applications, Buyers should provide adequate design and operating safeguards.

TI does not warrant or represent that any license, either express or implied, is granted under any patent right, copyright, mask work right, or other intellectual property right relating to any combination, machine, or process in which TI components or services are used. Information published by TI regarding third-party products or services does not constitute a license to use such products or services or a warranty or endorsement thereof. Use of such information may require a license from a third party under the patents or other intellectual property of the third party, or a license from TI under the patents or other intellectual property of TI.

Reproduction of significant portions of TI information in TI data books or data sheets is permissible only if reproduction is without alteration and is accompanied by all associated warranties, conditions, limitations, and notices. TI is not responsible or liable for such altered documentation. Information of third parties may be subject to additional restrictions.

Resale of TI components or services with statements different from or beyond the parameters stated by TI for that component or service voids all express and any implied warranties for the associated TI component or service and is an unfair and deceptive business practice. TI is not responsible or liable for any such statements.

Buyer acknowledges and agrees that it is solely responsible for compliance with all legal, regulatory and safety-related requirements concerning its products, and any use of TI components in its applications, notwithstanding any applications-related information or support that may be provided by TI. Buyer represents and agrees that it has all the necessary expertise to create and implement safeguards which anticipate dangerous consequences of failures, monitor failures and their consequences, lessen the likelihood of failures that might cause harm and take appropriate remedial actions. Buyer will fully indemnify TI and its representatives against any damages arising out of the use of any TI components in safety-critical applications.

In some cases, TI components may be promoted specifically to facilitate safety-related applications. With such components, TI's goal is to help enable customers to design and create their own end-product solutions that meet applicable functional safety standards and requirements. Nonetheless, such components are subject to these terms.

No TI components are authorized for use in FDA Class III (or similar life-critical medical equipment) unless authorized officers of the parties have executed a special agreement specifically governing such use.

Only those TI components which TI has specifically designated as military grade or "enhanced plastic" are designed and intended for use in military/aerospace applications or environments. Buyer acknowledges and agrees that any military or aerospace use of TI components which have **not** been so designated is solely at the Buyer's risk, and that Buyer is solely responsible for compliance with all legal and regulatory requirements in connection with such use.

TI has specifically designated certain components as meeting ISO/TS16949 requirements, mainly for automotive use. In any case of use of non-designated products, TI will not be responsible for any failure to meet ISO/TS16949.

### Products

Audio	<a href="http://www.ti.com/audio">www.ti.com/audio</a>
Amplifiers	<a href="http://amplifier.ti.com">amplifier.ti.com</a>
Data Converters	<a href="http://dataconverter.ti.com">dataconverter.ti.com</a>
DLP® Products	<a href="http://www.dlp.com">www.dlp.com</a>
DSP	<a href="http://dsp.ti.com">dsp.ti.com</a>
Clocks and Timers	<a href="http://www.ti.com/clocks">www.ti.com/clocks</a>
Interface	<a href="http://interface.ti.com">interface.ti.com</a>
Logic	<a href="http://logic.ti.com">logic.ti.com</a>
Power Mgmt	<a href="http://power.ti.com">power.ti.com</a>
Microcontrollers	<a href="http://microcontroller.ti.com">microcontroller.ti.com</a>
RFID	<a href="http://www.ti-rfid.com">www.ti-rfid.com</a>
OMAP Applications Processors	<a href="http://www.ti.com/omap">www.ti.com/omap</a>
Wireless Connectivity	<a href="http://www.ti.com/wirelessconnectivity">www.ti.com/wirelessconnectivity</a>

### Applications

Automotive and Transportation	<a href="http://www.ti.com/automotive">www.ti.com/automotive</a>
Communications and Telecom	<a href="http://www.ti.com/communications">www.ti.com/communications</a>
Computers and Peripherals	<a href="http://www.ti.com/computers">www.ti.com/computers</a>
Consumer Electronics	<a href="http://www.ti.com/consumer-apps">www.ti.com/consumer-apps</a>
Energy and Lighting	<a href="http://www.ti.com/energy">www.ti.com/energy</a>
Industrial	<a href="http://www.ti.com/industrial">www.ti.com/industrial</a>
Medical	<a href="http://www.ti.com/medical">www.ti.com/medical</a>
Security	<a href="http://www.ti.com/security">www.ti.com/security</a>
Space, Avionics and Defense	<a href="http://www.ti.com/space-avionics-defense">www.ti.com/space-avionics-defense</a>
Video and Imaging	<a href="http://www.ti.com/video">www.ti.com/video</a>

### TI E2E Community

[e2e.ti.com](http://e2e.ti.com)